



KNAUF



***PERMAROCK®
STEEL-FRAMED
COMMERCIAL FACADE
SYSTEM***

PERMAROCK® Cement Board Outdoor

PERMAROCK®

Build on us.

The PERMAROCK Exterior Facade System is engineered for certainty and creative freedom, performing across the spectrum of projects—from demanding seaside and hospitality structures to large-scale commercial and public buildings.



Markor Cave | Beijing, China

System introduction

PERMAROCK® Exterior Facade System is a high-performance, economical and lightweight solution for external walls.

Outstanding protection against high humidity and moisture

This high-performance system is an ideal solution for exterior facades, especially those exposed to moisture, heavy wind loads, and harsh coastal environments. Engineered and rigorously tested, its components deliver the highest standards of performance and durability in construction.

Our PERMAROCK® Cement Board Outdoor is naturally water-resistant and made from inorganic materials, that prevents the formation and spread of mould and mildew.

Complete Knauf system

With PERMAROCK® Exterior Facade System you get a complete Knauf solution from the internal environment, incorporating Knauf plasterboard and insulation, to the external with products from partners Rondo and Proclima. PERMAROCK® products and systems have been extensively tested to meet the requirements of the National Construction Code and relevant Australian Building Standards.

Plasterboard: Knauf plasterboard to suit a variety of internal applications

Steel framing: Rondo steel framing system designed to support PERMAROCK® Cement Board Outdoor

Insulation: Knauf glasswool insulation with a variety of thermal values to suit numerous applications

Weather barrier: Proclima Solitex Extasana

Exterior Facade: PERMAROCK® Cement Board Outdoor

Options for external finishes

Knauf recommends a proprietary render system from specialist companies such as Sto, Dulux, Euromix and Astec or equivalent, as well as tiles.

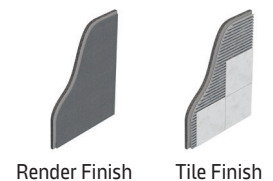

Engineering and project support

Our team of engineers and specification managers will provide you with support throughout the project; from conceptual design, to reviewing architectural drawings and site support to help you ensure optimum performance in design and construction.

PERMAROCK®

CEMENT BOARD OUTDOOR

Benefits

- › Simple installation
 - › Easy to cut, score and snap
 - › No pre-drilling for fasteners
 - › Resistant to moisture and driving rain
 - › Mould and mildew-resistant
 - › Dimensionally stable, robust and durable
 - › Not deemed combustible (AS 1530.1-1994)
 - › Fire resistant - adhere to Bushfire Attack Level (BAL) requirements, up to BAL40 in accordance with AS 3959-2018
 - › Creative design opportunities
 - › Options for the creation of curved exterior facades
 - › Spectacular seamless surfaces, thanks to expansion joints that are only needed every 15 m to enable a 225 m² closed area without a visible joint*
- › Steel frame exterior walls with PERMAROCK® Cement Board Outdoor. Proclima Solitex Extasana weather barrier system and proprietary render system fulfills the AS/NZS 4284 requirements and complies to the NCC F3V1 and H2V1.
 - › System tested in Australia to meet the NCC requirements for weatherproofing F3V1 & H2V1.
 - › Suitable for external wind pressure of 2.5 kPa Serviceability Limit State (SLS) and 5.0 kPa Ultimate Limit State (ULS) tested.

*A control/movement joint must be installed if there is a control/movement joint in the structure underneath.



Merchant House | Sydney, Australia



J'Ever Tower | Pyeongtaek, South Korea

Physical properties - PERMAROCK® Cement Board Outdoor

Length (mm)	3,000
Width (mm)	1,200
Thickness (mm)	12.5
Min. bending radius for 1,200 mm wide board (m)	3
Min. bending radius for 300 mm wide strip (m)	1
Weight (kg/m ²)	approx. 16
Dry bulk density (kg/m ³) according to EN 12467	approx. 1,150
Bending strength (MPa) according to EN 12467	≥ 7
Tensile strength perpendicular to the plane of the board (N/mm ²) according to EN 319	0.65
Shearing strength (N) according to EN 520	607
pH-value	12
Thermal conductivity (W/mK) according to EN ISO 10456	0.35
Thermal expansion (10 ⁻⁶ K ⁻¹)	7
Water vapour diffusion coefficient μ (-) according to EN ISO 12572	66
Length variation 65% - 85% humidity (mm/m) according to EN 318	0.23
Thickness variation 65% - 85% humidity (%) according to EN 318	0.2
Building material class according to AS 1530.1-1994	NOT deemed COMBUSTIBLE



Hotel Royal | Serbia



Lingang Warehouse | Shanghai, China

Bend the rules of design

PERMAROCK® Cement Board Outdoor can be bent with a radius of 3 m (full board) and 1 m (300 mm strips).

For truly unique designs, use double studs.

This technique enables you to create walls with distinct interior and exterior profiles, such as a surface that curves inward on the outside and outward on the inside.

Arrangement of PERMAROCK® Cement Board Outdoor with different radii

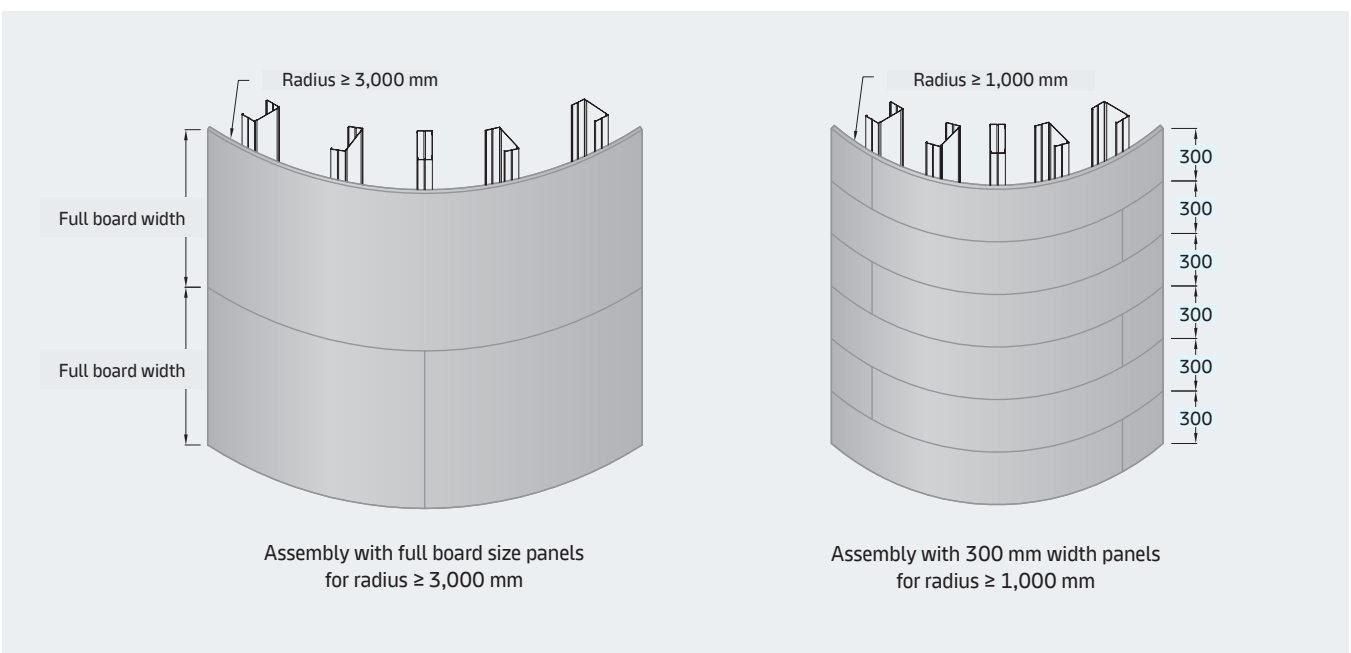

PERMAROCK® Exterior Facade System

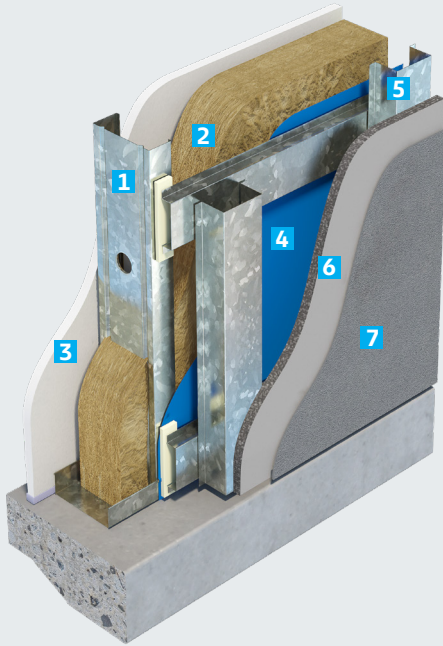

1. Rondo steel stud framing as per structural requirements
2. Knauf insulation to achieve thermal performance
3. Knauf plasterboard lining as required
4. Proclima Solitex Extasana weather barrier by others
5. Rondo steel top hats framing as per structural requirements
6. PERMAROCK® Cement Board Outdoor
7. Proprietary render system or tiles

PERMAROCK® Exterior Facade System has been tested in Australia to meet NCC weatherproofing F3V1 and H2V1 requirements.

Overall Total Thermal Resistance, R _T		
	winter	summer
50G14 glasswool R1.26, 50 mm	1.35	1.28
90G24 glasswool R2.61, 90 mm	1.72	1.65
90G32 glasswool R2.73, 90 mm	1.75	1.68



Scan for [CAD Library](#)

Note: Calculated by James M Fricker Pty Ltd in accordance with AS/NZS 4859.1:2018 and AS/NZS 4859.2:2018 standards.

The calculations follow the isothermal planes method and area-weighted averaging as per AS/NZS 4859.2:2018 Clause 4.3, considering in-service conditions, including adjustments for temperature and infrared emittance. Results are specific to the described systems and may vary if construction details differ.

Material of substructure	Steel framework	
	0.6 ≤ x ≤ 1.0	1.0 < x ≤ 2.0
Metal thickness (mm)	Single layer	Single layer
Number of board layers	Single layer	Single layer
Knauf Maxi Screw SN25	x	
Knauf Maxi Screw SN39	x	
Knauf Maxi Screw SB25		x
Knauf Maxi Screw SB39		x

Notes:

1. Minimum distance from the screw to the edge of the board is 15 mm.
2. Maximum distance from the corner of the board to the screw is 50 mm.
3. Screws should be equally spaced.

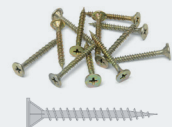

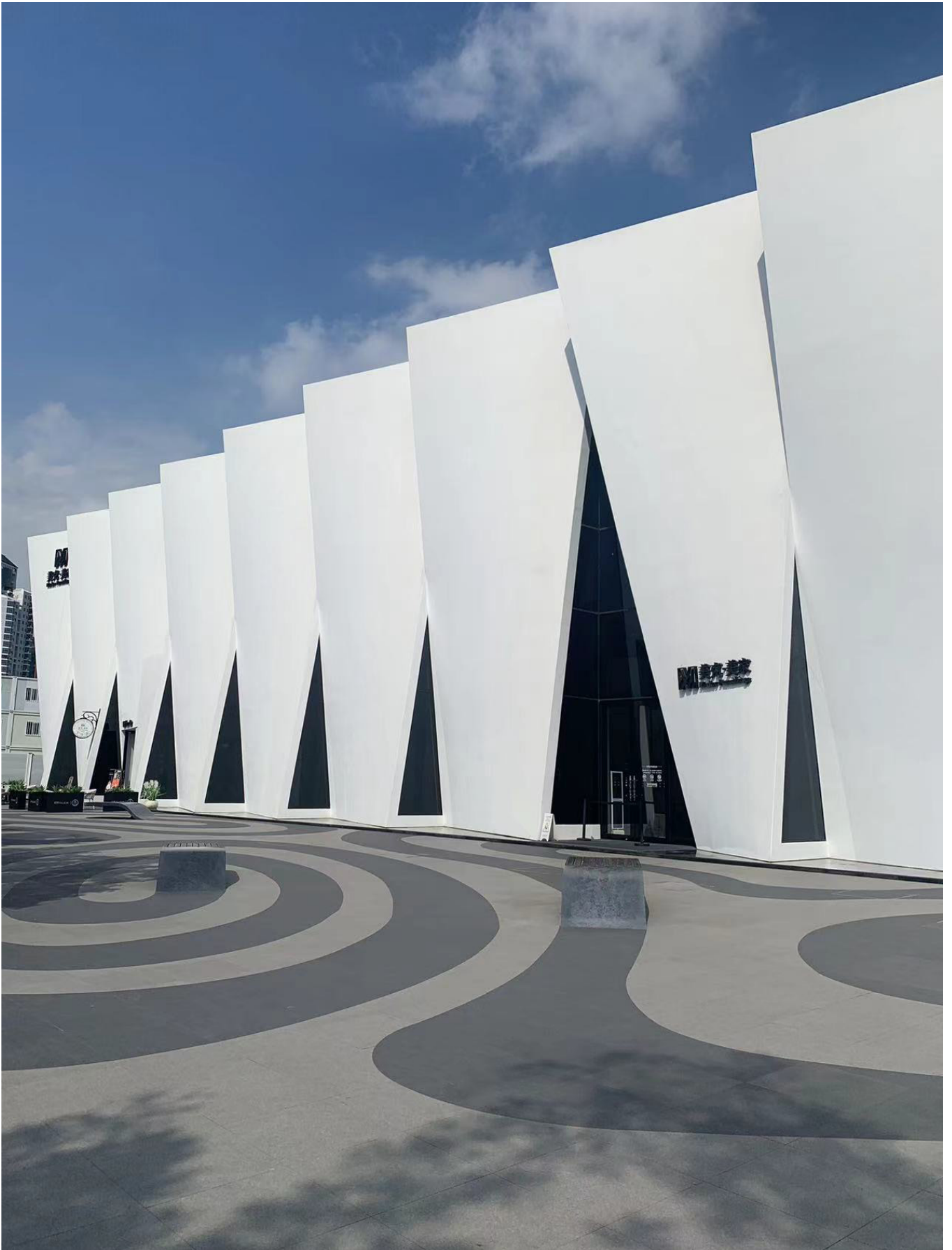

Markor Cave | Beijing, China

Installation

Step 1: RONDO Vertical Stud Installation

Install RONDO studs vertically in accordance with design requirements and local regulations.

Step 2: Weather Barrier Installation

Install Proclima SOLITEX EXTASANA® weather barrier onto the RONDO studs following Proclima assembly guidelines and local regulations. Ensure any penetrations/openings (windows, pipes, cables etc.) in the weather barrier is treated adequately to maintain performance, refer Proclima for details.



[Proclima Guide](#)

Step 3: Thermal Break and Top Hats Installation

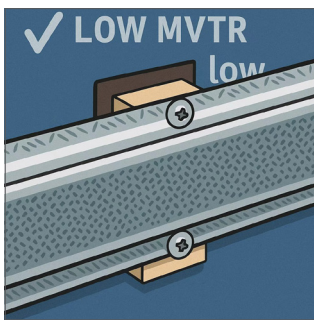

Stick the thermal breaks or packers to the weather membrane with Proclima TESCON® NAIDECK and then screw the horizontal top hat through them fixing it to the vertical stud. Then screw the vertical top-hats to the horizontal top hats according to RONDO's design and assembly guidelines.

Step 4: PERMAROCK® Cement Board Outdoor Installation



4.1 Mark the desired shape or opening on the board with pencil and ruler. Use a knife to score the cement on one side along the line so that the mesh is cut. Snap the scored edge and cut the mesh/paper on the rear side.

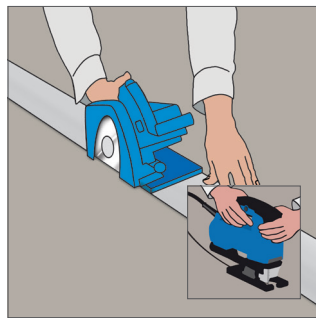

4.2 For sharp-edged cuts, for example, exterior edges, use a hand-held circular saw with a dust extractor or a pendulum jigsaw. It is recommended to use a carbide or diamond-tipped saw blade that is fully circular with no teeth.

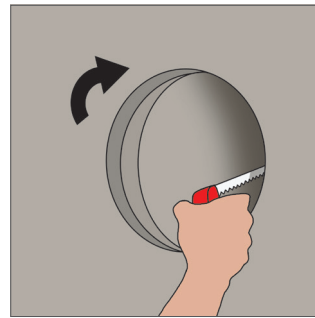

4.3 To make cut-outs for wiring and pipes, use a jigsaw or hole saw. The diameter of the opening should be approximately 10 mm greater than the diameter of the pipe. The remaining gap can be closed with a cuff, suitable sealant or sealing strip.

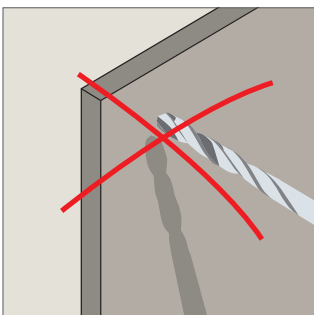
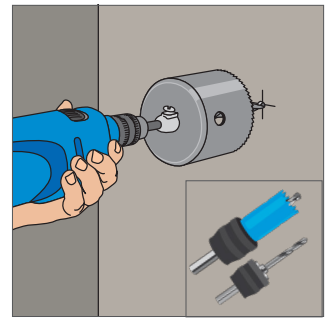

4.4 Generally, no pre-drilling of boards is required. However, pre-drilling of boards and profiles is needed if the material thickness of the profiles exceeds 2 mm (according to static requirements) or when blind rivets are used instead of screws.

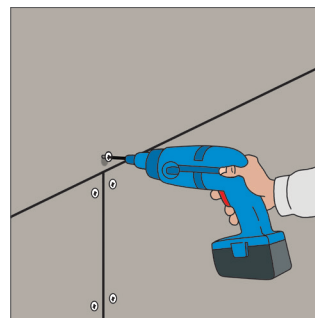

4.5 To fasten the boards with screws, use a screw gun with depth stop (comprising overturned sleeve and a stop sleeve). This ensures that all screws are countersunk in the same correct way. Fasten PERMAROCK® Cement Board Outdoor to the top hat frame with Knauf Maxi Screws. First, fasten the screws in the center of the cement boards, then work towards the edges. During installation, make sure the cement boards fit closely to the substructure. Screws should not be overtightened

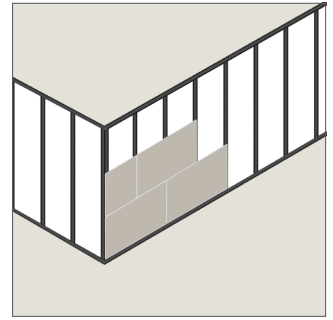
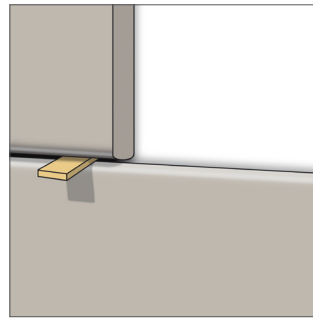
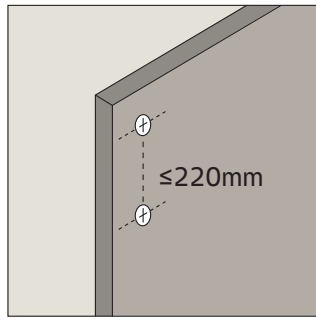
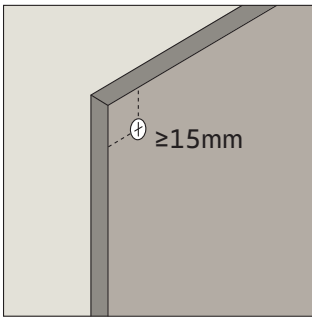

4.6 Follow rules of distances: the screw spacing must not exceed 220 mm and the spacing from the edge must be at least 15 mm.

4.7 Apply PERMAROCK® Cement Board Outdoor panels horizontally. Arrange front edge joints (vertical) on centre of the top hat fixing face. Leave a gap of 3-5 mm between boards alongside the long and front edges (horizontal and vertical) using a suitable spacer. Front edge joints (vertical) must be staggered by at least one stud spacing.

Note: The membrane and horizontal top hats are not shown for clarity. Hairline cracks on the surface of PERMAROCK® Cement Board Outdoor are no indications of loss of strength or function, as long as embedded glass fibre mesh is intact.

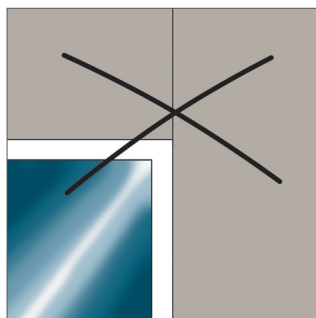
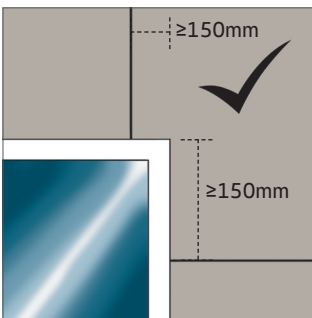

4.8 Take the boards up to the parapet, reveals and parapet of the window or the door. There must be no continuous joints as these could lead to cracks and leaks. The spacing between the board joints and the imaginary extensions (horizontal and vertical) of the window frames has to be at least 150 mm.

Board vertical edges alignment with openings is not recommended.

Step 5: Joint Treatment Installation

Apply the proprietary joint treatment in accordance with the manufacturer's assembly guidelines and recommendations.

Finish Options

OPTION 1 – Render Finish

Step 6: Install the proprietary exterior render and texture system as per the manufacturer's assembly guidelines and recommendations. Refer to companies, such as Sto, Dulux, Astec, Masterwall, Rockcote and Euromix.

OPTION 2 – Tiled Finish

Step 6: Prime the surface as per Ardex specifications and assembly guidelines.

Step 7: Apply waterproofing (if required) using Ardex specifications and assembly guidelines.

Step 8: Install the tiles using Ardex tile adhesive as per the manufacturer's assembly guidelines.

Step 9: Grout tiles to Ardex specification at least 24 hours after applying the tile adhesive following Ardex assembly guidelines.

Exterior Facade Projects



Lingang Warehouse | Shanghai, China



Joali | Maldives



Starbucks | Daecheon, South Korea



Hunan Broadcasting System Program Production Center | China

Knauf Gypsum Pty Ltd.

3 Thackeray Street,
Camellia NSW 2142
Australia

TecASSIST™ +1800 811 222

Sales Enquiries +1800 003 377

www.knauf.com

Technical Resources



CAD Library



eSelector

© 2026 EN-05/28

©2026 KNAUF GYPSUM PTY LTD. The trademarks KNAUF, TecASSIST and PERMAROCK are trademarks of Knauf Gypsum Pty Ltd or one or more of its affiliates including Knauf Gips KG.

Product availability should be checked with your local Knauf sales office as availability may vary. The technical information contained in this manual was correct at the time of printing. Building systems, details and product availability are, however, subject to change. To ensure the information you are using is current, Knauf recommends you review the latest building information available on the Knauf website. For further information, contact TecASSIST™ or your nearest Knauf sales office. Knauf Gypsum Pty Ltd ABN 84 004 231 976 17/47 Turner Street Port Melbourne VIC 3207