



KNAUF

**METAL
CEILING
SOLUTIONS**

Installation Manual

Build on us.

Index

1 GENERAL INFORMATION

A	General Installation Conditions	6
B02	METAL General	14

2 SUSPENSION SYSTEMS

C01	T-Grid	20
C02	U-Profile Primary Grid	28
C03	C-Channel	40
C04	Primary Angle	44
C05	DP12 A-Bar	48

3 EXPOSED GRID CEILINGS

D02.001	METAL Board / METAL Axal Vector / METAL MicroLook / METAL Tegular	T-Grid	56
D02.002	METAL R-L 201	U-Profile primary grid	62
D02.002.1	METAL R-L 201	Primary Angle primary grid	68
D02.002.2	METAL R-L 201	Direct suspended	76
D02.003	METAL B-L 302	U-Profile primary grid	82
D02.004	METAL B-H 300	U-Profile primary grid	88
D01.004.1	METAL B-H 300	Direct suspended	96
D02.005	METAL K-H 400	Direct suspended	104

4 CONCEALED GRID CEILINGS

D02.100	METAL Q-Clip / METAL Q-Clip F / METAL R-Clip	U-Profile primary grid	116
D02.100.1	METAL Q-Clip / METAL Q-Clip F / METAL R-Clip	DP12 A-Bar primary grid	124
D02.100.2	METAL Q-Clip / METAL Q-Clip F / METAL R-Clip	Direct suspended	132
D02.102	METAL T-Clip F	C-Channel primary grid	140
D02.102.1	METAL T-Clip F	U-Profile primary grid	146
D02.103	METAL K-Clip	U-Profile primary grid	152
D02.103.1	METAL K-Clip	DP12 A-Bar primary grid	162
D02.103.2	METAL K-Clip	Direct suspended	172
D02.104	METAL R-H 200 / METAL Q-H 100 F	U-Profile primary grid	180
D02.104.1	METAL R-H 200 / METAL Q-H 100 F	Primary Angle primary grid	190
D02.104.2	METAL R-H 200 / METAL Q-H 100 F	Direct suspended	200
D02.105	METAL R-H 215	U-Profile primary grid	210
D02.105.1	METAL R-H 215	Direct suspended	218
D02.106	METAL R-H 220 / METAL Q-H 120 F*	U-Profile primary grid	226
D02.106.1	METAL R-H 220 / METAL Q-H 120 F*	Direct suspended	234

*swiss market only

5 GRILLE - OPEN CELL

D02.300	METAL Grille Cellio	T-Grid	244
---------	---------------------	--------	-----

6 FREE SPAN CORRIDOR SOLUTIONS

D02.400	METAL F-L 601	Perimeter trim	250
D02.401	METAL F-Clip	Half DP12 A-Bar	256
D02.401.1	METAL F-Clip	DP12 A-Bar	264
D02.402	METAL F-H 600	J-Bar	272
D02.403	METAL F-H 600 SWING	G-Profile	280

7 FLOATING CEILINGS - CANOPIES

E02.001	METAL Sonic Element	Direct suspended	290
E02.002	METAL Sky Element Clip	U-Profile primary grid	292
E02.003	METAL Sky Element HOOK	U-Profile primary grid	298

8 LINEAR & BAFFLE SOLUTIONS

E02.100	METAL Baffle Element	U-Profile primary grid	306
E02.100.1	METAL Baffle Element	Direct suspended	312
E02.310	METAL Linear Lite	Carrier profile	316
E02.311	METAL Linear Blade	Carrier profile	326
E02.312	METAL Linear Stripe	Carrier profile	336

9 WALL SOLUTIONS

F02.100	METAL Wallcoustic Horizon 1000	C-Wall Profile	346
F02.101	METAL Wallcoustic Horizon 1100	U-Wall Profile	352
F02.400	METAL Wallcoustic Element	Wall brackets	360

10 PERIMETER TRIMS & TRANSITIONS

T02.001	METAL Perimeter Solutions		364
T02.002	METAL Steel Bulkhead Solutions		368
T02.003	METAL Aluminium Bulkhead Solutions		378

11 CUTTING & MODIFICATIONS

U02	METAL Cutting & Modifications		390
-----	-------------------------------	--	-----

12 MAINTENANCE & CLEANING

V02	METAL Maintenance & Cleaning		396
-----	------------------------------	--	-----



METAL R-Clip
Trumpf, Warsaw, Poland
© Szymon Polański



General Information

General Installation Conditions

Brief overview

This installation manual replaces all previous documents. It contains information for specifiers and installers of suspended ceilings and wall applications.

Field of validity and application

The installation manual is to be regarded as an application standard and does not represent a complete reference to other existing standards. All statements and guidelines given concerning structural design refer exclusively to Knauf Ceiling Solutions products. It defines dimensions, tolerances on dimensions and necessary installation requirements for suspension and ceiling elements for interiors. In addition, the installer is obliged to observe any project-related specifications and individually applicable standard requirements. This installation manual is also in line with the guidelines provided in Annex A and Annex B of the suspended ceiling standard EN 13964.

For some areas, however, this installation manual is not valid. These are as follows:

- ceilings in means of transport
- heating and cooling ceilings
- air leakage
- thermal insulation
- ceilings with seismic requirements, except specific indicated solutions.
- ceilings subject to requirements regarding ingress of water
- ceilings for exterior applications, for which other extended requirements apply (tunnels, shelters, petrol stations, arcades, public sports facilities, car parks etc.), except specific indicated solutions.
- suspended ceilings or its supporting structure, on which you can walk
- ceilings with specific requirements for corrosion resistance, dynamic and/or static effects of loads (swimming pools, underground railway stations etc.)

For mountings of all kinds, the regulations documented here are to be observed.

All specifications and technical information in this manual or other publications referring to Knauf Ceiling Solutions products are based on test results, according to EN 13964. Technical modifications in the interest of improvements may be made by Knauf Ceiling Solutions at any time without prior notice.

The currently valid version can be obtained from Knauf Ceiling Solutions or can be downloaded directly from our website www.knauf.com.

Safety

Thin-gauged materials, particularly profiles and cut tile edges, are to be handled with due care in order to prevent injuries and damage. It is the obligation and full responsibility of the ceiling fixer to ensure sufficient safety.

Quality

Knauf Ceiling Solutions is certified in accordance with the ISO 9001 quality standard. For material properties, dimensional accuracy and coloration, our quality standard shall apply.

The installer is responsible for the quality of the finished ceiling, carried out according to the installation instructions shown in this document.

Fire protection

Knauf Ceiling Solutions delivers suspended ceiling components, which can be assembled and form fire protective barrier. Ceiling components have to be assembled in accordance with relevant classification report and country-specific and must comply with the requirements in accordance with EN 13501-1 (Reaction to fire), EN 13501-2 (Resistance to fire) and the country-specific standards and regulations.

Corrosion

In their standard version, Knauf Ceiling Solutions Suspension components are made of galvanised sheet steel or aluminium and thus protected against corrosion in accordance with EN 13964, provided that they are not exposed to any extreme corrosive atmospheres or emissions and the corrosion protection is not damaged during installation or the assembly of parts not supplied by Knauf Ceiling Solutions.

If it is evident from the design that contact corrosion can occur between different materials, this is to be pointed out by the planner and appropriate protective measures defined in accordance with EN ISO 12944-3 point 5.10.

To counteract the danger of condensation forming in ceiling cavities, sufficient rear ventilation of the ceiling construction is to be ensured. It is always advisable to consult a specialist.

General Installation Conditions

A

Statics

In terms of their load-bearing capacity and fitness for use (deflection), all systems documented in the installation instructions are statically tested and documented. Technical documentation of loadbearing elements is in accordance with the valid European Standard EN 13964. Please specify the desired, permitted deflection e.g. EN13964, class 1-3 in advance.

Additional loads are not provided for in their standard version. Apart from that of the dead load, the system constructions described have no load-bearing capacity for other components and are to be attached to supporting components. Neither the suspension nor the top layer must be walked on. The customer is responsible for defining the relevant additional loads and their written documentation.

Material expansion

The expansion of the ceiling construction as a result of temperature fluctuations due to exposure to direct sunlight or the failure of the air conditioning system is usually unproblematic. With very large ceiling areas and different material expansion coefficients, however, this may lead to issues.

Special attention should be paid here to wall joints and, if necessary, expansion joints. Careful, detailed planning and accurate installation are therefore all the more important.

Transport and storage

During transport and subsequent storage, the elements should be protected from moisture, high humidity and weather. Plastic packaging is not waterproof.

Attention should be given to the underlying surface which should be clean, dry and flat (full surface support) to avoid soiling or damage. Elements from different production dates / batches should not be installed within the same area. Recognisable, visibly damaged and broken parts (tiles, profiles, accessories, etc.) must not be installed.

Handling

It is essential to carefully handle both full cartons as well as individual elements, in accordance with workplace safety standards. They must not be thrown, dragged, pushed or slid across the floor. Cartons and elements should not be stood or turned on their corners or edges. No heavy objects should be placed on the cartons. Even short-term external influences can lead to damage. We recommend that any risks that may arise from this type of handling are carefully assessed.

To remove the elements, the packaging should be opened and removed all the way around. Individual elements should be handled carefully, preferably using suitable, clean installation gloves (white material).

Installation conditions

Knauf Ceiling Solutions elements should only be installed once all wet trades have been completed, building is sealed with doors and windows fitted and the room completely dried out. The heating system should be in operation in order to ensure a working temperature of 15 - 20°C. Before starting the installation, we recommend taking measurements with regards humidity and temperature. It is not recommended to start the installation if the relative humidity is over 70%.

During the subsequent period of use, the relative humidity may not exceed 90% or 95% depending on the type of tile used (see product data sheet).

In rooms with continually high relative humidity, special provisions should be made (see installation guidelines for wet rooms and swimming pools).

Improper handling and lack of observation of the installation conditions invalidates all warranties.

Installation

The individual installation company is responsible for correct, perfect installation as well as observance of the system standards specified here. Knauf Ceiling Solutions products and systems should only be installed by qualified and experienced fixers in order to maintain the high product quality of the Knauf Ceiling Solutions products. Any materials that are visibly damaged or exhibiting recognisable optical or technical impairments must not be installed. In this case, please contact Knauf Ceiling Solutions.

Fixings

The fixing of the perimeter trim to adjacent walls as well as the installation of the hangers and cross bracing should be carried out with appropriate and approved fixings (by others). As this is dependent on what material is being fixed to, the choice of fixing should always be carried out in consultation with the fixing manufacturer and approvals (ETA: European Technical Approval).

General Installation Conditions**A****General installation sequence**

- 1 Read the Knauf Ceiling Solutions installation instructions carefully.
- 2 Check the ceiling layout drawings or installation sketch based on the actual building conditions.
- 3 Determine the location and layout of ceiling elements (Main Runners and Cross Tees / primary and secondary grid, etc) according to instructions.
The position of the service integrations must also be taken into account.
- 4 Construction site equipment (scaffolding, assembly area, ladders, power connection, etc.).
- 5 Check the soffit and walls for the appropriate type of fixings.
- 6 Attach perimeter trims to the walls at the specified height / level. Depending on the construction of the walls, choose the appropriate type of fixings. For perimeter solutions see separate datasheet.
- 7 Determine the grid direction and mark suspension points on the structural soffit in the exact module dimensions.
The suspension and profile distances must be as specified.
- 8 Align the grid system according to the specifications and fix to the structural soffit with the selected suspension method. Check the squareness.
- 9 Install the ceiling elements. At the perimeter, the ceiling elements have to be cut to size on site.
- 10 In the course of installing the ceiling elements, the service integration components must also be installed.
Heavy service integrations must be suspended separately.
- 11 Align ceiling elements with precise joints and clean any soiled areas as specified.
- 12 Ceiling acceptance by construction management.

General Installation Conditions

A

Recommended layout for square tiles

Layout 1 - Not recommended

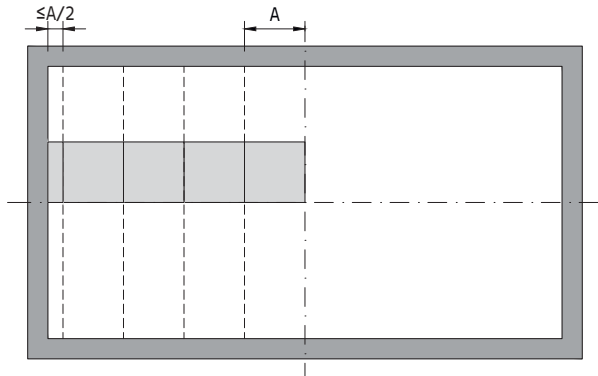

Layout 2 - Not recommended

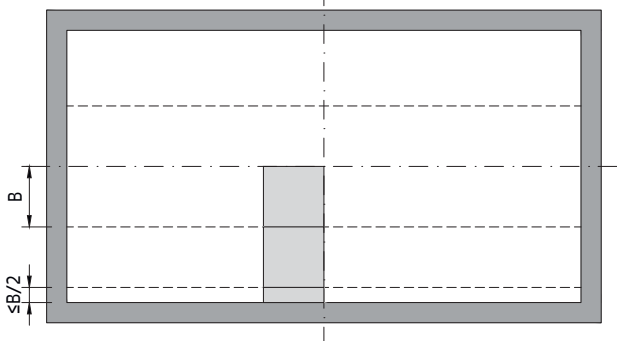

Layout 3 - Recommended

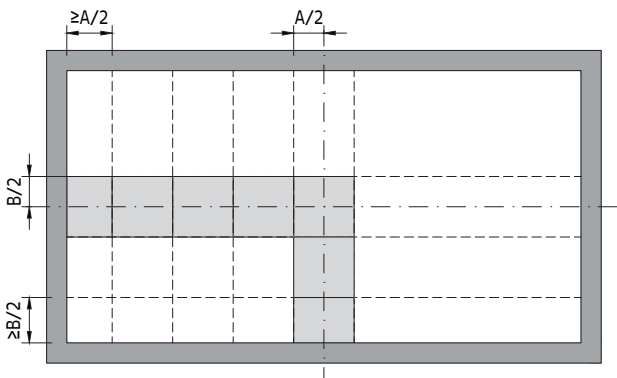

Layout 1 / 2

The ceiling is set out from the middle of the room in modules. In the example shown, the cut tile at the perimeter is very small.

Tile length (A) = tile width (B)

If the cut tile is less than half the tile length (A) or width (B), the layout is not recommended and should be avoided. In addition to requiring more profiles, small cuts appear aesthetically poor. If layout 1 and / or 2 does not provide the desired visual appearance (small tile cuts), layout 3 should be chosen.

Layout 3

Ceilings with larger cut tiles are aesthetically more pleasing and are more efficient to install. When setting out the ceiling, start from the middle. Ideally the first tile should be directly on the centre line (half the tile each side of the centre) unless this results in a small perimeter cut in which case align the tile edge with the centre line.

The layout then continues in the other direction.

General Installation Conditions

A

Recommended layout for rectangular panels

Layout 1 - Not recommended

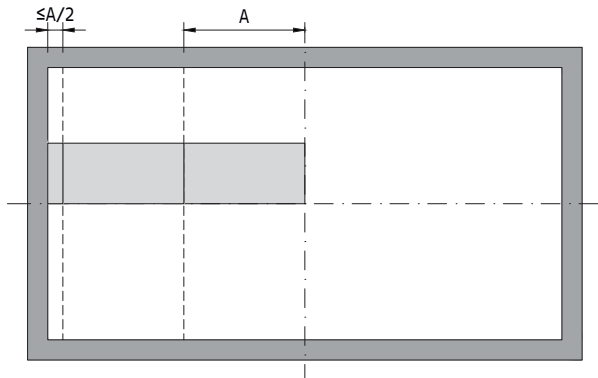

Layout 2 - Not recommended

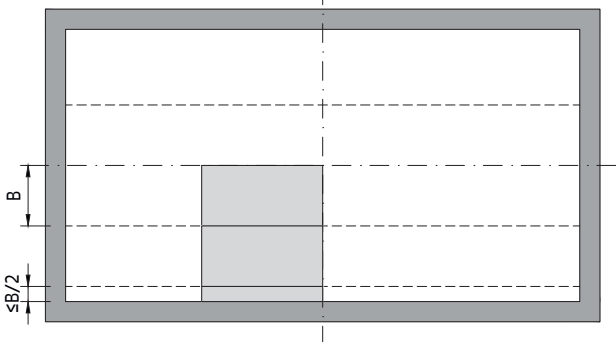

Layout 3 - Recommended

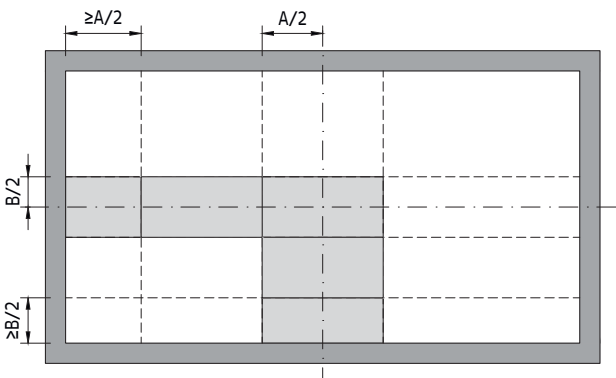

Layout 1 / 2

The ceiling is set out from the middle of the room in modules. In the example shown, the cut panel at the perimeter is very small.

Panel length (A), panel width (B)

If the cut panel is less than half the panel length (A) or width (B), the layout is not recommended and should be avoided. In addition to requiring more profiles, small cuts appear aesthetically poor. If layout 1 and / or 2 does not provide the desired visual appearance (small panel cuts), layout 3 should be chosen.

Layout 3

Ceilings with larger cut panels are aesthetically more pleasing and are more efficient to install. When setting out the ceiling, start from the first panel should be directly on the centre line (half the panel each side of the centre) unless this results in a small perimeter cut in which case align the panel edge with the centre line.

The layout then continues in the other direction.

General Installation Conditions

A

Recommended layout for linear grid

Layout 1 - Not recommended

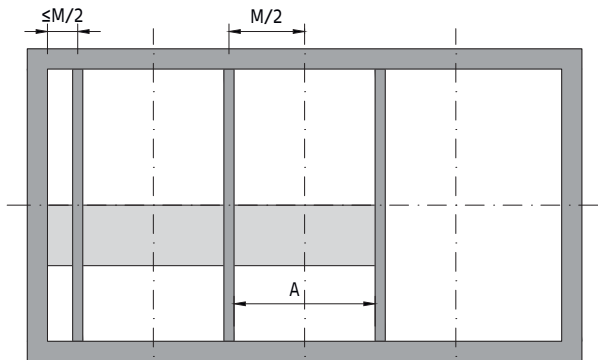

Layout 2 - Not recommended

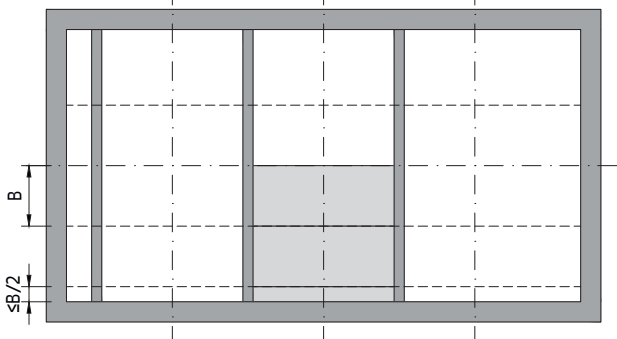

Layout 3 - Recommended

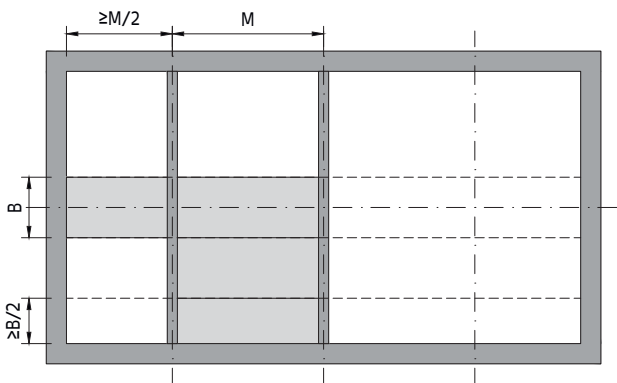

Layout 4 - Guide string / angled rooms and walls

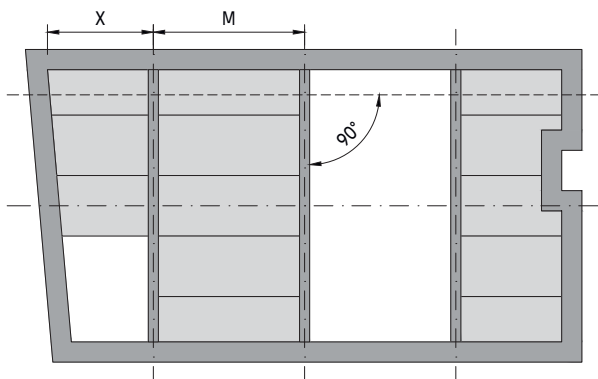

Bandraaster module

Each element has an overlay on the Bandraaster. The overlay depends on the selected ceiling system. See individual document for more information.

C-Profile module

Since the plates sit between the profiles, the C-Profile width must be subtracted to get the correct panel length (A).

Module length (M), panel length (A), panel width (B)

Layout 1 / 2

If the cut panel is less than half the module length (M) or width (B), it could appear aesthetically poor and is therefore not a recommended layout.

Layout 3

Usually the building center dimension specifies the alignment. The ceiling layout follows this modularisation.

If the layout of the building allows it, it is aesthetically more pleasing and more efficient to install a ceiling with larger cut panels. This will result in a cut panel length greater than half the module length (M) and therefore a correct layout.

Layout 4

As the rest of the installation follows the first panel, special care should be taken to ensure its correct installation. In order that the joints are aligned with the Bandraaster, it is helpful to span a guide string or laser level across the entire room's length. Starting from this reference line, the panels are cut to fit. It is usually enough to measure the width adjacent to the linear grid and then transfer it to the panel to be cut (the element width should be measured in two places). This can then be cut accordingly. The guide string can help to achieve a parallel joint pattern. Wall unevenness can also be better compensated for. Should the cut panels meet with an angled wall, the longest side (X) should equal the panel length; otherwise the layout should be adjusted.

General Installation Conditions

A

Recommended layout for baffles

Layout 1 - Not recommended

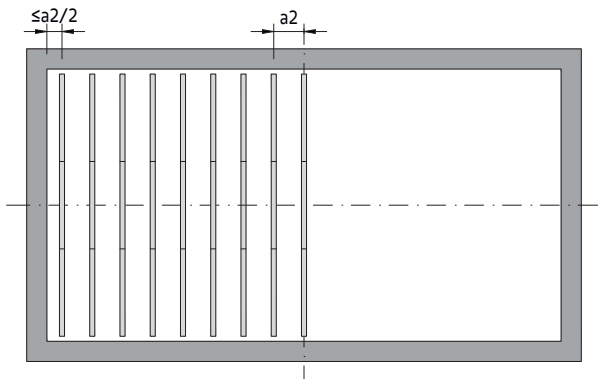

Layout 1

Starting from the middle of the room, the layout continues in baffle distances of ($a2$). The example shown results in a very small distance between the last baffle and the wall. If the last baffle distance to the wall is smaller than half ($a2$), the layout is not recommended for optical reasons.

Layout 2 - Not recommended

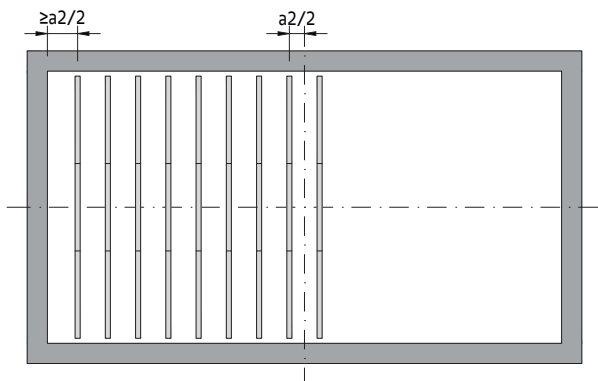

Layout 2

It is aesthetically more pleasing and more efficient to install a baffle ceiling with a larger distance between the last baffle and the wall. If, as described above, the baffles are set out from the middle of the room but results in an unfavourable layout, the baffle layout should be moved over by half of a distance ($a2$). This always results in a baffle distance to the wall larger than half a distance ($a2$).

Layout 3 - Recommended

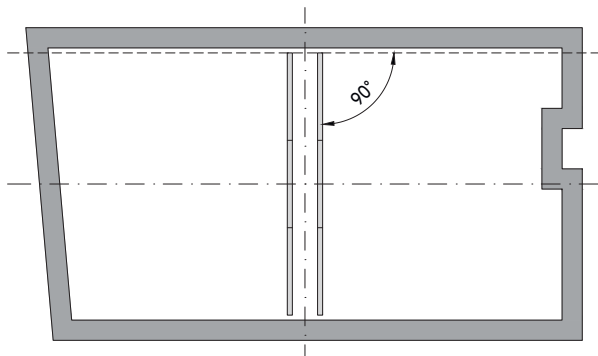

Layout 3

In order that the baffles are aligned in one row, it is helpful to span a guide string or laser level across the entire room's length. Starting from this reference line, the baffles can be aligned in long direction. The guide string can help to achieve a parallel layout. Wall unevenness can also be better compensated for.

General Installation Conditions

A

Canopy layouts

Where available, positioning devices provided in the packaging can simplify the alignment of the floating ceilings. Especially with non-rectangular shapes, such as circular, etc

Recommended layout for corridors

Layout 1 - Not recommended

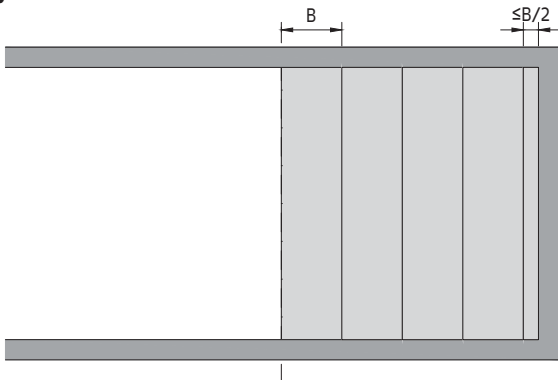

Layout 1

Starting from the middle of the corridor, the layout continues in element widths (B). The example shown results in a very small cut panel width (B). If the last cut panel is smaller than half a panel width, the layout is not recommended for optical reasons. If layout 1 does not provide the desired visual appearance (small panel cuts), layout 2 should be chosen.

Layout 2 - Recommended

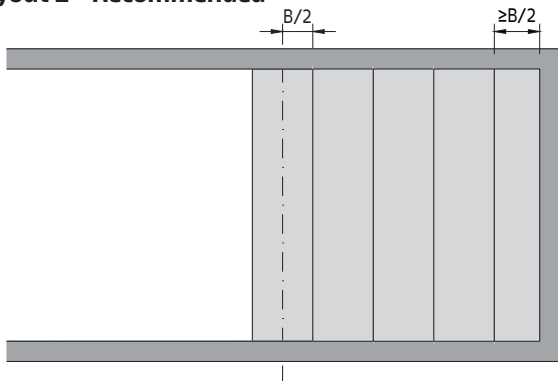

Layout 2

It is aesthetically more pleasing and more efficient to install a ceiling with larger cut panels. If, as described above, the ceiling is set out from the middle of the corridor but results in an unfavourable layout, the ceiling layout should be moved over by half a module width. This always results in a cut panel larger than half a panel width (B).

METAL General Information

Base material

Material composition

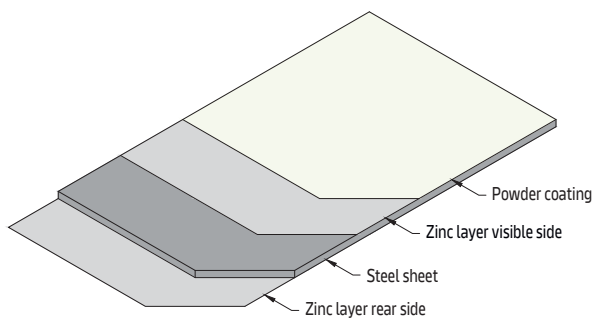

The metal ceiling and wall solutions from Knauf Ceiling Solutions are generally offered in galvanised steel. Some of the products can be made of aluminum on request. The material thickness depends on the selected product and the dimensions. Square tiles are manufactured with a gauge of 0.5 to 0.6 mm, rectangular panels with 0.6 – 0.7 mm and further products such as bulkheads, wall solutions, etc. in 1.0 mm. Knauf Ceiling Solutions also offers pre-coated products which have a separate specification.

Surface/coating

The standard finish is a high quality powder coating. A selection of popular colours is offered, other colours are available on request. By default, the visible side is coated, including edges that are defined as visible. All other surfaces are not supplied fully coated, which applies to the back and non-visible edges. Small colour differences can occur between the metal elements and the profiles, wall angles, etc. Since the surfaces can yellow over time, subsequent items may show a colour difference. A low gloss level is recommended, otherwise reflections will make the ceiling appear more restless and the sagging of the elements will be emphasised (pillow effect). Whenever the coated surfaces are touched, this should always be done with soft white gloves, otherwise fingerprints will be left on the surface, which makes cleaning more time consuming.

Patterns/acoustic infills

Unperforated border

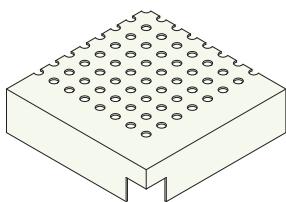

Over border perforated

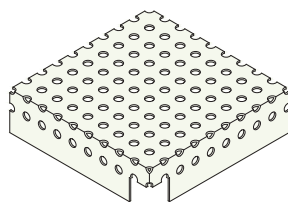

Smaller patterns up to 1.0 mm hole size are perforated over the edge. All other patterns are delivered with an unperforated border. This dimension depends on the selected pattern and the dimensions of the element. On request, patterns up to 2.5 mm hole size can be over border perforated. Perforations with large holes and/or a large open area may increase the panel deflection, surface warping and affect product stability. The standard insert is a black acoustic fleece, which is glued in at the factory. Be careful with the acoustic fleece so that it is not damaged during handling and installation. For higher acoustic requirements, acoustic pads or factory-bonded mineral boards (Premium infills) can be supplied. This increases the weight of the ceiling and can have an impact on the panel deflection. The spacing of the suspension system must be adjusted accordingly. The value +4 kg/m² should therefore be used for the specific systems. Higher loads must be checked and approved.

METAL General Information

B02

Dimensions/deflection/tolerances

1 Clip in with square tiles

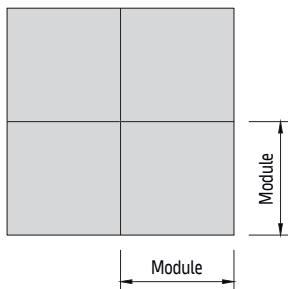

2 Lay-in with square tiles

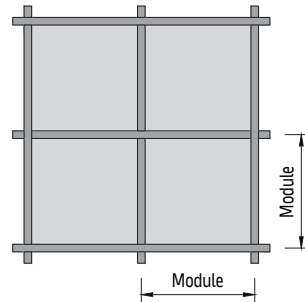

Square and rectangular tiles are specified in modular dimensions, such as 600 x 600, 625 x 625, 1200 x 600 mm. It doesn't matter whether these are the effective dimensions (1) or the distances between the T-Grid (2), though this difference should be noted.

With configurable rectangular panels in the Vario Design range, a distinction must be made between module size and actual dimensions (manufacturing size).

3 Clip-in or hook-on with rectangular panels

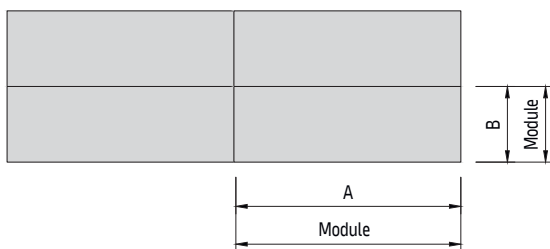

Example: Ceiling module size 2000 x 400 mm

(3) Clip-in or hook-on = 2000 x 400 mm

(4) Hook-on with gasket = 1997 x 397 mm

(5) Linear with C-profile 100 mm + gasket = 1894 x 397 mm

This logic is applicable to all systems and products shown in this literature.

4 Hook-on with rectangular panels + gasket

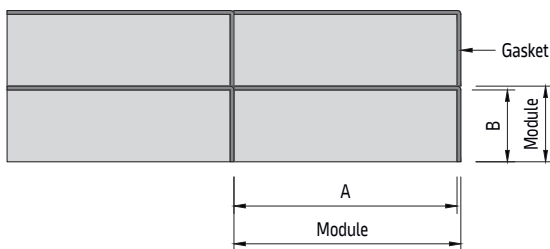

When planning and ordering, the rectangular panel (6) is shown reclined and from the rear side, with the long side C at the top, the long side D at the bottom, the short side E on the left and the short side F on the right. This allows each side to be uniquely defined. The upstands on the long sides C / D are responsible for the stability of the panel and therefore for the flatness of the ceiling. The longer the panel, the higher the upstands.

5 Linear grid with rectangular panels + gasket

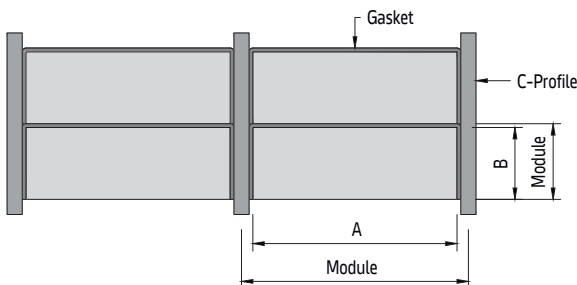

Large panels have an increased risk of being damaged during transport, handling and installation. Therefore, it is recommended not to exceed the specified limits. The panel width in particular is critical, as this is responsible for increased deflection in the centre of the panel. If less deflection is desired, the panel width should be kept narrow. Reduce the width and use two panels instead of one wide one, if possible.

6 Rectangular panel parameters (example with gasket)

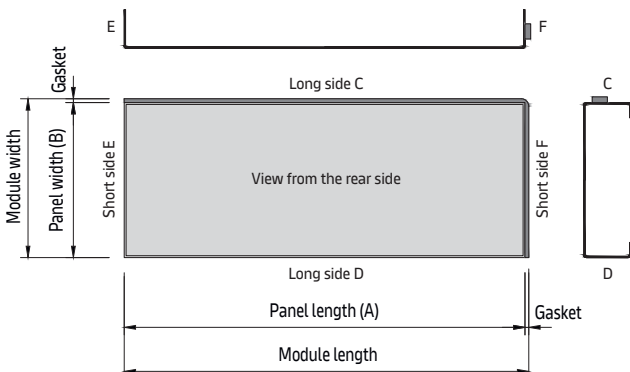

Tolerances and deflection are in accordance with EN 13964. Perforations with big hole size and/or a high free cross section must be checked and approved separately.

METAL General Information

B02

Joint Details

Ceiling elements

Square edged



The bending radius depends on the selected material gauge. The thicker the gauge, the bigger the radius.

Bevel edged

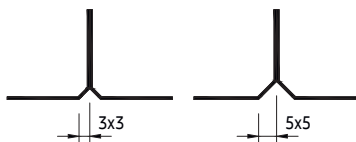

Depending on the product, a 3x3 or 5x5 mm bevel is available.

Square edged, with gasket

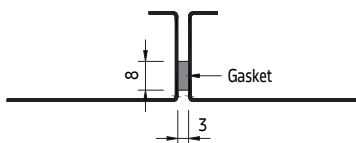

The joint is covered and "flexible"

Square edged, with spacer

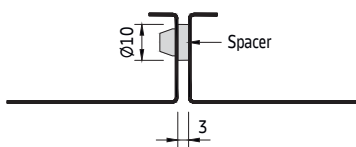

The joint is open and fixed to the spacer width

Square edged, with gasket + spacer

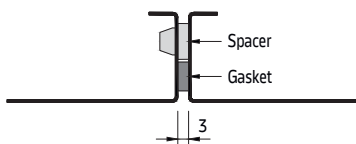

The joint is covered and fixed to the spacer width

Wall elements

Square edged, with gasket + spacer

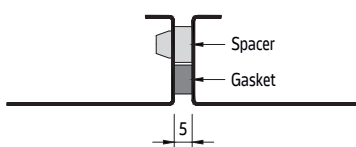

The joint is covered and fixed to the spacer width

Storage of products with a gasket

Correct Storage

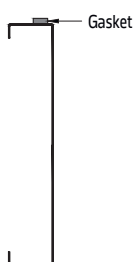

Wrong Storage

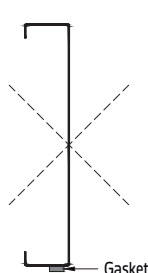

With clip-in solutions, the elements are installed in such a way that they touch, i.e. without a gap in between. Depending on the system, either a square or bevel edge is available. The bevel forms a small "reveal" between the visible sides and helps to conceal any height differences between the elements. These are usually standard modules with fixed dimensions.

Most hook-on and lay-in rectangular panel solutions are designed with a 3 mm gasket as standard. This gasket, consisting of a PE foam, is used to accommodate any tolerances (length, width, squareness) and facilitates the installation and clean alignment of the panels. The more often the panels are removed and reinstalled during building maintenance, the more the joint pattern can shift. The gasket conceals and mitigates this so that the layout looks more homogeneous. Therefore the use of a gasket is recommended, especially for bespoke solutions, such as trapezoidal and triangular panels.

The panel dimensions are made smaller by the gasket width so that they fit into the module. This should be taken into account when ordering.

The gasket is fitted at the factory. For bespoke solutions, it may happen that the gasket rolls are delivered as a spare and attached on site.

The panels should never be stored with the gasket on the bottom and the weight pressing on it. That would permanently damage the gasket. It should also be ensured that the gasket in systems that can be demounted with an extraction tool, is not damaged during removal. Optionally, most products can be supplied without a gasket. Instead of a gasket, plastic spacers or PE glue-on spacers can be used on most systems. The spacers guarantee a minimum distance between the panels while leaving the joints open. This can be used, for example, when air flow is desired or the ceiling is installed with a slope. The gasket would be compressed. The spacers are installed at the factory and are available on request.

Continuous wall solutions are supplied with a 5 mm gasket and spacers at the horizontal and vertical joints. The gasket covers the joint and the spacers keep the distance.

METAL General Information

B02

Cut-outs

Cut-out type 1

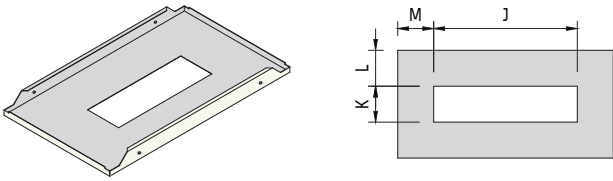

Cut-out type 2

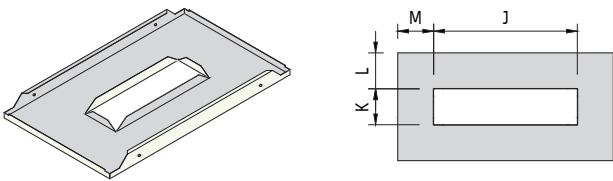

Cut-out type 2A

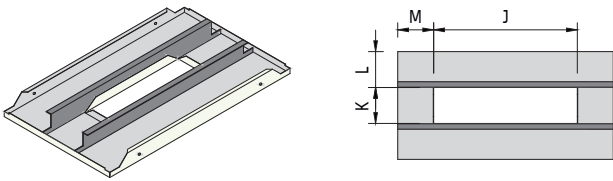

Cut-out type 4

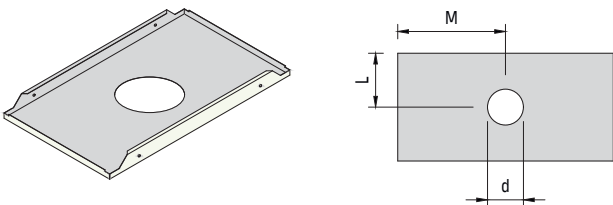

Ventilation & loudspeaker perforations

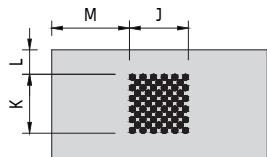

Cut-outs for service integrations can be cut on site (see separate pages for cutting & modifications). If there are a large number of panels with the same cut-outs, these can be manufactured at the factory.

There are various options to choose from, starting with round (type 4) or rectangular flat (type 1) cut-outs with an upstand (type 2), up to rectangular cut-outs with an upstand and with additional reinforcements (type 2A).

With type 1 and 4, the edge is covered by the service integration. Type 2 can be used when using a service integration without a border that hides the edge. This version can also be used with additional welded reinforcement profiles, where the load is transferred to the short sides. Since this option depends on various parameters, the panel deflection should be checked and approved on site by a mock-up.

In the case of prefabricated cut-outs, the position in the panel as well as the dimensions must be defined. The distances to the edges and dimensions of the cut-out depend on the selected system. Cut-outs and service integrations can affect panel stability and deflection.

On request, several cut-outs per panel can be made. A further option is ventilation and loudspeaker perforations. The options are available upon request.

When planning and ordering, the rectangular panel is shown reclined and from the rear side.

Demountability

In general, all standard and configurable products can be removed individually. This ensures access to the cavity. For clip-in systems, extraction tools are required. Choosing the right tool is crucial and prevents damage to the product.

When using security clips and brackets then individual tiles cannot be removed. The modules have to be dismantled from the last one that was not secured. Use systems like METAL R-H 200 and METAL R-H 215 that use clips that can be locked / unlocked from below. Various hinge-down and swing-down solutions are available to facilitate access.



METAL Tegular
Slimming World Headquarters, Alfreton, United Kingdom
© Simon Miles



Suspension Systems

T-GRID (System C)

Exposed grid solution for indoor applications

General information

- Suitable for indoor use only
- All profiles meet durability class B, according to EN 13964
- All standard items are held in stock
- Various suspension options available, depending on market needs
- Tried and tested solution with extensive experience

Main Runners

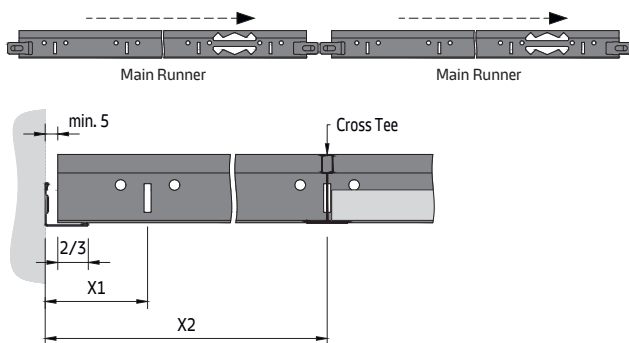

The Main Runners should always be installed in the same direction; two fire expansion notches should not be installed directly next to each other. Main Runner cuts result depending on the ceiling symmetry as well as the cut tile width. The profiles should be cut to length so that the punching and therefore the layout of the Cross Tees is aligned. For every new row, the dimension X1 or X2 should be checked. To ensure system alignment (squareness) and stability, all profile cuts should leave a 5-10 mm perimeter gap. In addition, the profile should sit on the trim to at least 2/3 of the trim flange width.

Main Runner / Cross Tee connection

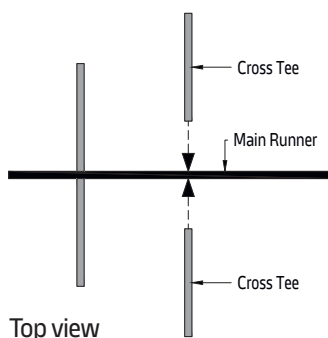

The handling of the Cross Tee connectors will differ during assembly, depending on the selected grid system (plug / click with audible engagement; left / right aligned), but also during disassembly.

Important information

The appropriate grid system and layout must be determined based upon the tile weight and additional loads. The corresponding load information and available components can be found in the respective datasheets. Components (Main Runners and Cross Tees) from different systems cannot be mixed.

Tile installation direction

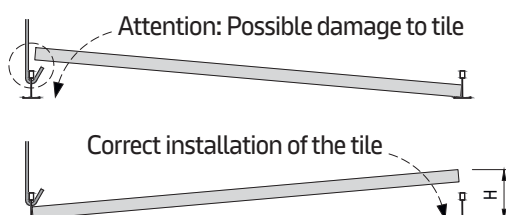

Particularly when using wire hooks, there is risk of damaging the tiles during installation. Please note the installation diagram opposite. Demounting should be carried out accordingly (lifting the tiles on the side with no hanger). In principle, assembly and disassembly should not be carried out starting from Main Runners, as there is always a risk of collision with a hanger and damage to the tile edges. The minimum height (H) to be able to insert and remove the tiles depends on the chosen system and is covered in the specific chapter.

Square tiles

Layout 1

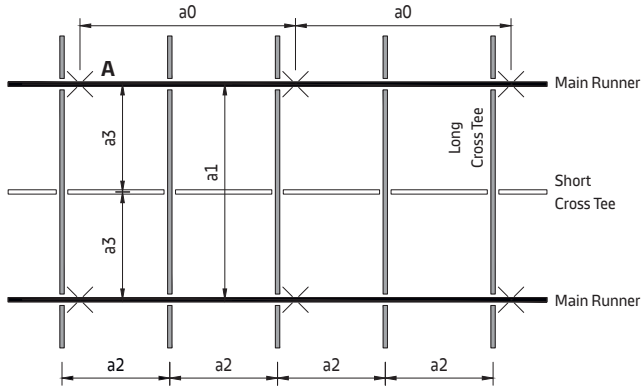

Between the Main Runners centres (a_1), a long Cross Tee is fitted at (a_2) centres. These Cross Tees are then subdivided by short Cross Tees at (a_3) to form the square module layout. The distance (a_0) stands for the distance between the suspension points.

Layout 2 - not permitted

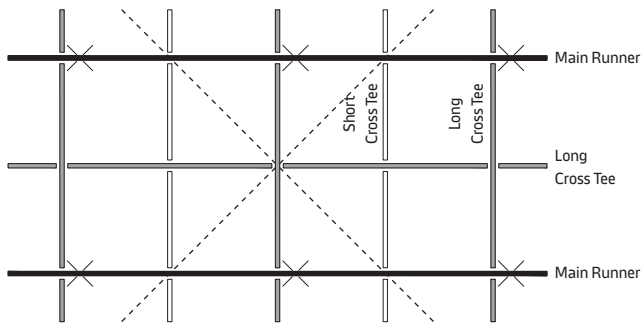

This construction is **not** permitted. A combination of long Cross Tee and second long Cross Tee parallel to the Main Runners due to increased deflection of the system.

Layout 3

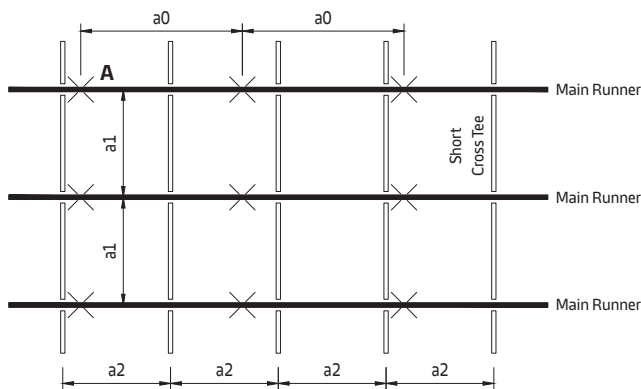

Due to the small Main Runner centres (a_1) and the use of short Cross Tees at (a_2) centres, this construction can support heavier loads. Long Cross Tees are omitted and therefore the material requirements of Main Runners and short Cross Tees is increased.

T-grid

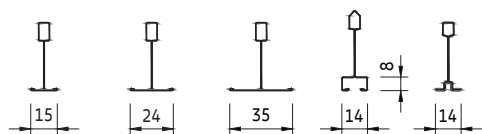

These are typical examples of T-grid. Detailed information and available options can be found in the product datasheets.

T-Grid (System C) C01

Parameters

- a0 Max. distance between Main Runner suspension points
- a1 Distance between Main Runners
- a2 Distance between long Cross Tees (module width)
- a3 Distance between Main Runner and short Cross Tees (module length)
- a4 Distance from wall to first suspension point = max. 250 mm

Values see specific data sheets of the products.

Rectangular tiles

Layout 1

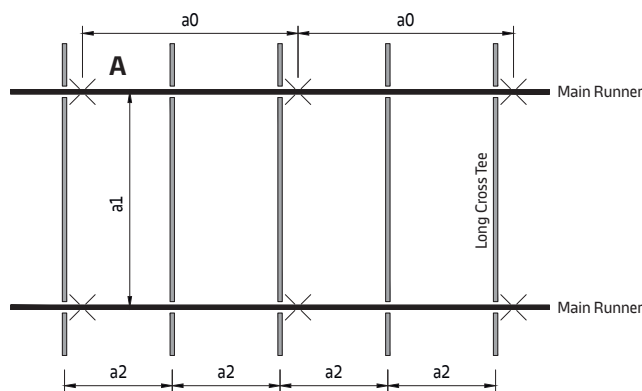

If the tiles are rectangular then the short Cross Tees are not required. Between the Main Runners centres (a1), a long Cross Tee is fitted at (a2) centres.

Layout 2 - not permitted

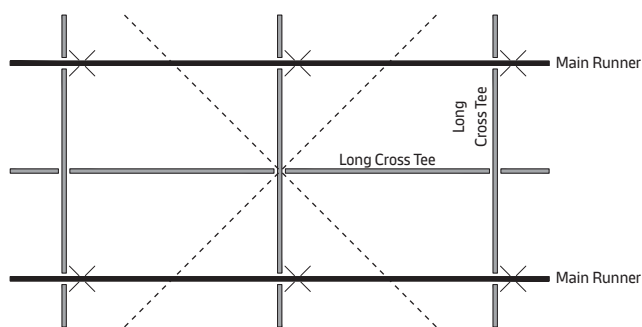

This construction is **not** permitted. A combination of long Cross Tee and second long Cross Tee parallel to the Main Runners due to increased deflection of the system.

Layout 3

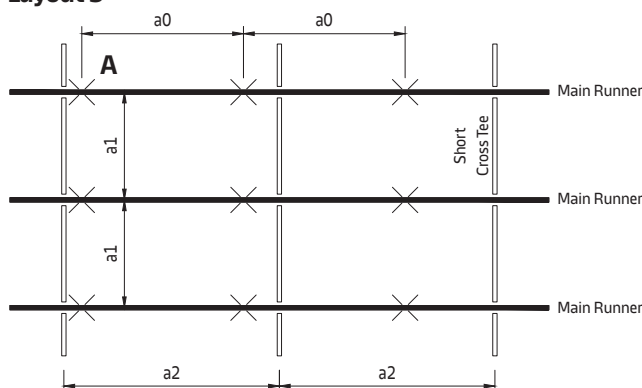

Due to the small Main Runner centres (a1) and the use of short Cross Tees at (a2) centres, this construction can support heavier loads.

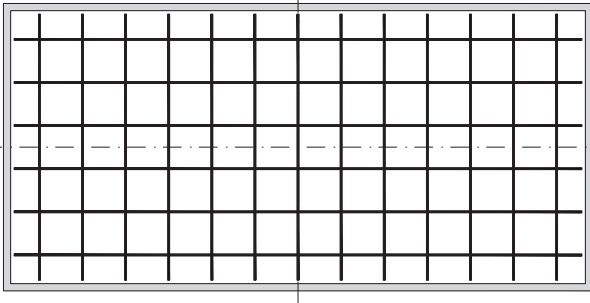
Installation guidelines**Layout 1**

After determining the ceiling symmetry / layout, the direction of the Main Runners is determined. The long side of the room is normally chosen, but sometimes due to fixtures and fittings etc., the short direction may be more favourable.

Perimeter trims

As preparation before the installation, all perimeter features (walls, columns etc.) should be marked with the ceiling height (the height of the top edge of the perimeter trim). Perimeter trims should be fixed as per chapter Perimeter trims (approved fixings, centres etc.).

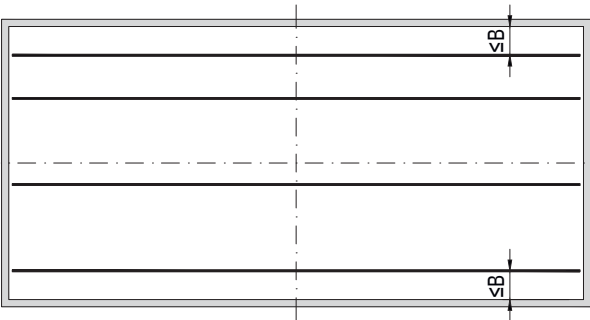
Layout 2

The fixing points of the hangers are determined by the layout of the Main Runners. The distance of the first and last Main Runner from the wall should be smaller than module width B, so that laying long Cross Tees on the perimeter trim is avoided.

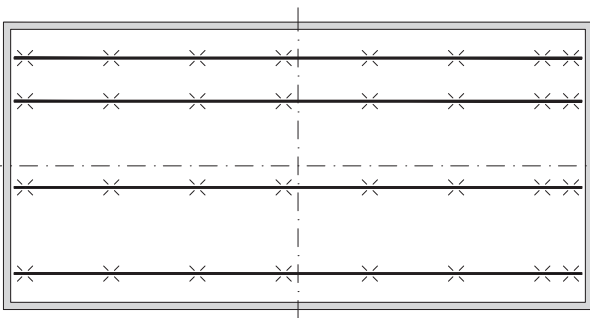
Layout 3

The fixing points are marked on the soffit using a chalk line, for example.

In addition to the relevant system hanger centres (load capacity of the grid system), additional hangers may be required for:

- Main Runner joints / fire expansion notches
- Maximum perimeter distances (first and last hangers)
- Fixtures and fittings

It is recommended that the hangers are adjusted to the required length before installation, later only the fine adjustment is required.

Soffit fixings is carried out with approved fixings as per the screw /plug manufacturer's recommendations. All hangers are to be installed in the same direction (e.g. direction of butterflies or hooks etc.) and vertical.

Layout 4

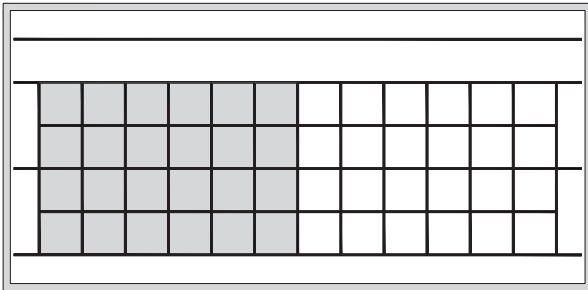

To complete the system, long and short Cross Tees are installed as required. To align and square the system, it is recommended to insert a few tiles and where necessary adjust the system before the entire grid system installation is complete.

Squareness check

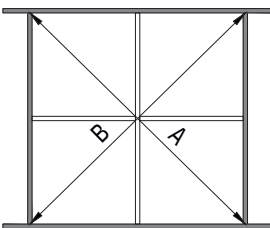

Diagonal A = Diagonal B

Please ensure that the system and the profiles are installed at right angles to each other or correct this where necessary. This should be done as early as possible in the installation to reduce realignment work to a minimum.

Failure to do so can lead to major problems when installing the tiles, especially with recessed edge designs, e.g. edges at...

MINERAL: Tegular 15, Tegular 24, Tegular 15/90 ...

HERADESIGN: SK-05, SK-06 ...

METAL / MESH / WOOD: Microlook, Tegular... and semi-exposed systems e.g. Vector edge.

Furthermore, there is an increased risk of damage to tiles during subsequent demounting or maintenance.

Layout 5

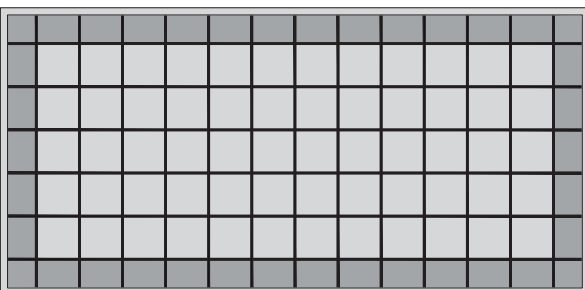

Finally, all profile and tile cuts are completed. The minimum support on perimeter trims should be adhered to.

Suspension heights

The following suspension heights enable simple installation of the tiles from below.

For low suspension heights, e.g. direct hangers, the profiles and tiles must be installed alternately.

T-Grid (System C)
C01

Hangers

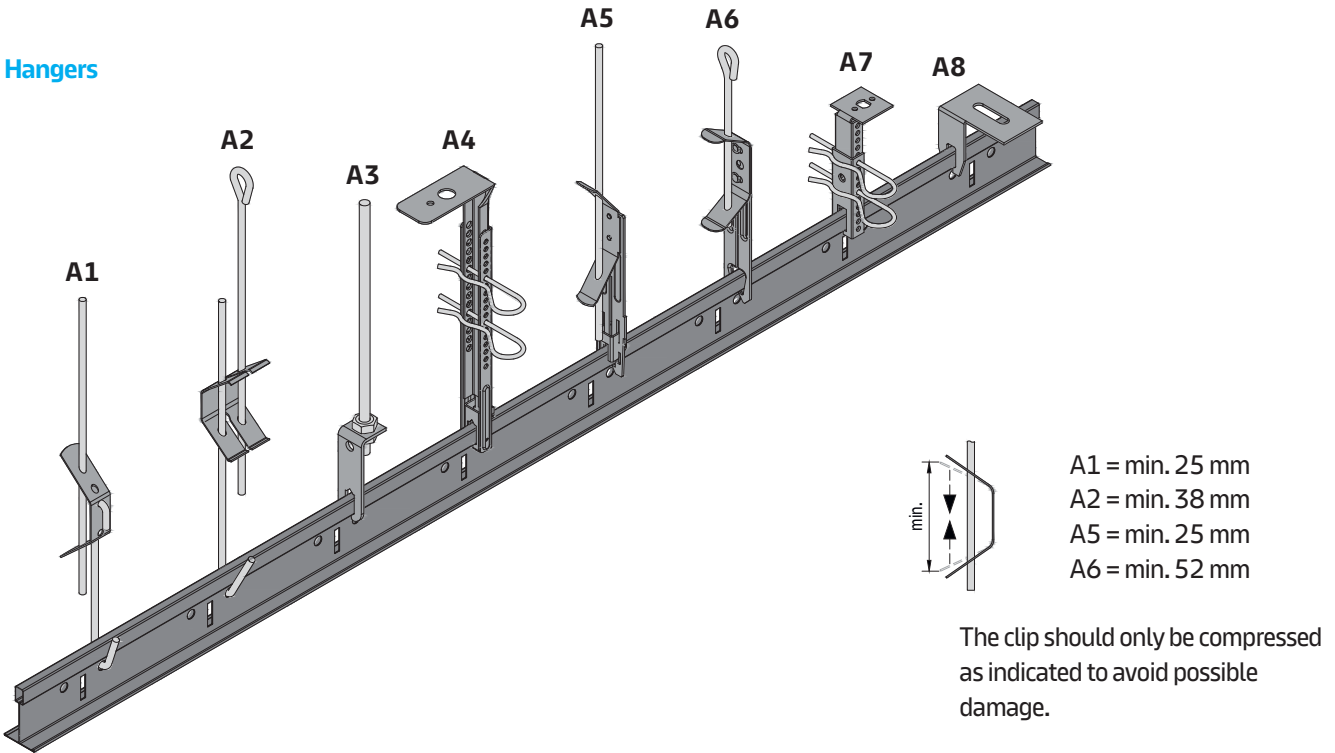

There is a range of suspension hangers available for the System C grid. Depending on the suspension height, object-related circumstances, availability or preference, all types can be used. It is important to ensure however, that the maximum load bearing capacity is not exceeded and the choice fits the system and the requirements.

In the case of push-on hangers, care is needed to ensure that installation and removal of the tiles does not displace the hangers. When using push-on hangers, the direction of installation should be at 90° to the Main Runners, tension free and vertical.

Hangers with visible defects must not be used. Improper handling, such as forcibly bending open and closed tabs / parts of the hanger, will result in a loss of load-bearing capacity.

Hanger type		Min. installation height (H) [mm]
A1	Butterfly hanger with hook	140
A2	Quick hanger with loop	100
A3	Bent tee bar hanger for threaded rod	100
A4	Nonius top and bottom part	200
A5	Hanger Clickfix II	130
A6	SAH10 plus	130
A7	Direct hanger	80
A8	Direct hanger	65

Not all combinations of grid systems / Main Runner and hanger are possible. This primarily applies to hangers for sliding on and clipping on due to the different profile head heights and shapes - rectangle / roof (peak).

T-Grid (System C) C01

Hanger installation

A2

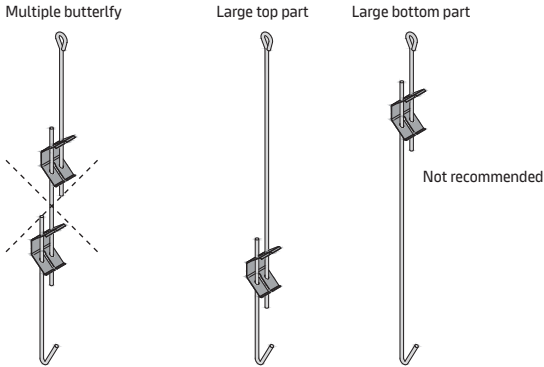

To facilitate access to the butterfly, it is recommended to use a longer eye wire (top part).

A4

Nonius hanger extension

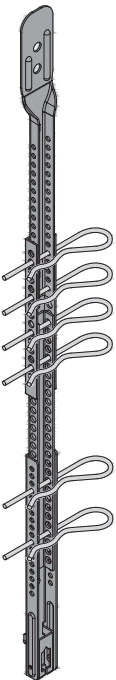

Hangers must be installed vertically. The maximum hanger distance depends on the selected product (see specific product datasheets). In addition, a hanger is required at each Main Runner join and additional loads for service integrations require a minimum of two hangers (see Cutting & Modifications document). It should be ensured, that the distance from the perimeter to the first and last hanger does not exceed the maximum dimension (see specific product pages) and additional hangers should be installed where required.

Angled hangers can significantly reduce the load bearing capacity and not all hangers are suitable for. In most cases, additional measures (cross bracing, additional hangers etc.) are required.

For suspension heights of up to 3000 mm, suitable suspension wires can be obtained as standard for different variants. For suspension heights over 3000 mm Nonius hangers (A4) are recommended.

A combination of multiple butterflies (A2) or extensions is not permitted. Greater suspension heights can be created using suitable special lengths (the longest possible upper section facilitates accessibility and subsequent adjustment). A combination of different hangers / parts is not permitted.

Hangers subject to compression

In normal situations the hangers are subjected to tension (ceiling tiles, grid structure, service integrations, etc.). Certain applications may subject the hangers to compression forces. These applications can only be carried out with Nonius hangers. It is only limited available and must be clarified in relation to the object. Please make sure that the elements have an overlap of at least 40 mm.

Fire rated applications

For fire rated applications, the relevant test certificates apply. Separate documents are available.

Perimeter hangers

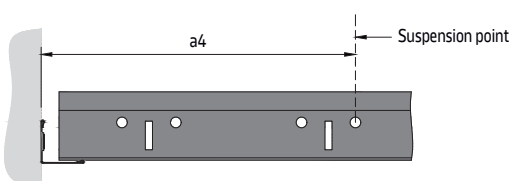

To avoid overloading the perimeter trim, the first hanger must be positioned at a maximum distance from the perimeter (a4). Depending on the system selected, the grid does not necessarily have to rest on the perimeter trim.



U-PROFILE PRIMARY GRID

Primary grid solution for indoor applications

General information

- Modular primary grid concept for small, medium, large rooms and floating solutions, with a minimum number of components
- For perpendicular installation with secondary grid
- High longitudinal and transverse stability
- Simple and time-saving installation, due to the use of system components
- All standard items are held in stock
- Various suspension options available, depending on market needs
- Tried and tested solution with extensive experience

Isometric view

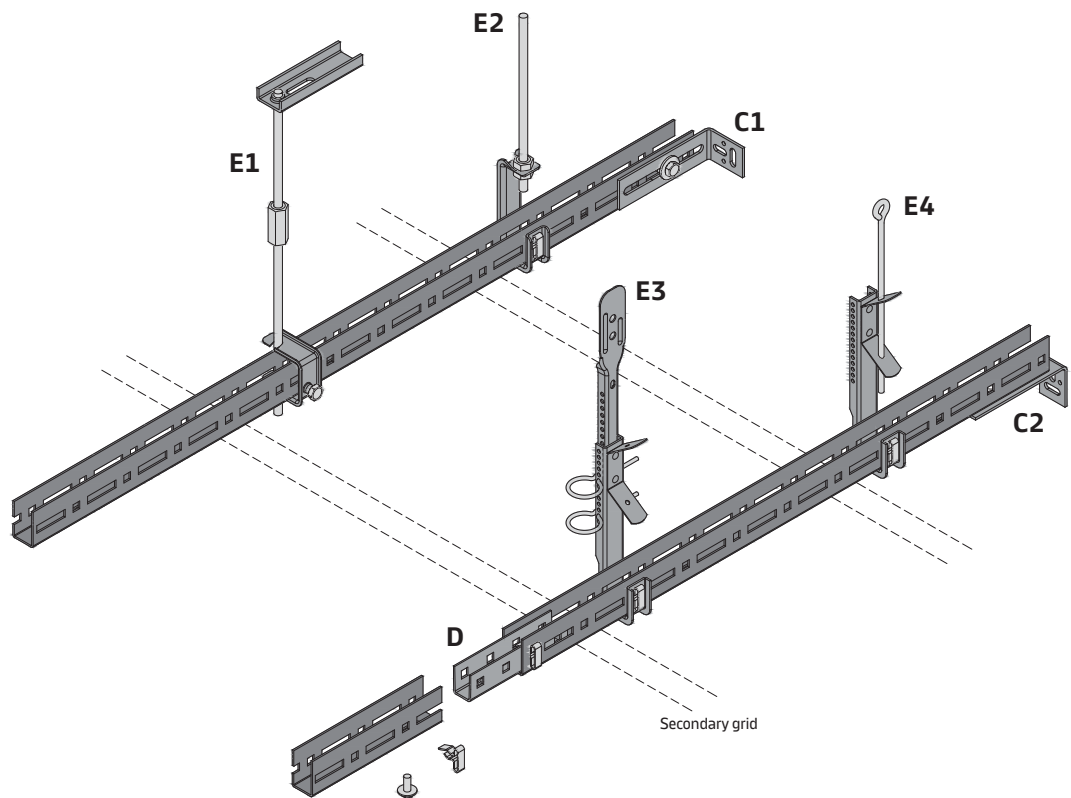

Important information

The U-Profile system fulfils the two conditions required in the European standard (EN 13964) concerning load-bearing capacity (2.5 times the failure criterion) and performance capability (deflection restriction).

Section A

Example with suspension option E1

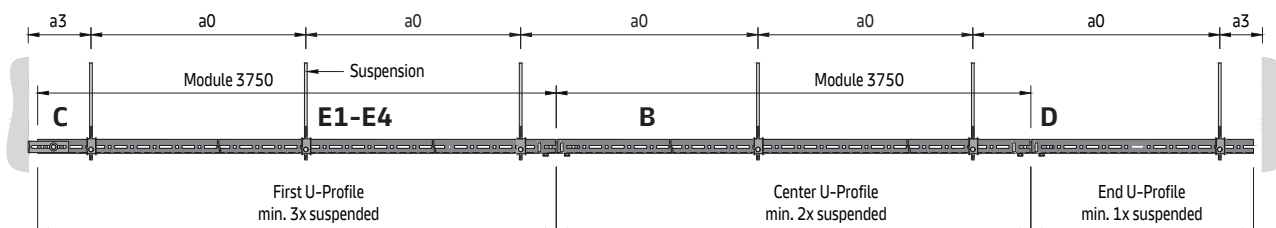

U-Profile Primary Grid C02

Primary grid components

Standard components

- M300100 U-Profile
- M300119 Splice connector for U-Profile
- M300140 Wall anchor
- M300120 Plug-in clip for U-Profile
- M311103 Hexagonal nut M6
- M311105 Washer
- M311303 Hexagonal bolt M6 x 16 mm

Suspension options E1 - E4 components

Suspension option D1

- M300121 Clamping bracket for U-Profile
- M311101 Threaded rod M6 x 1000 mm
- M311315 Hexagonal extension nut M6 x 30 mm (optional)
- M311061 Suspension element (optional)

Suspension option D2

- M300366 Hanger for U-Profile
- M311103 Hexagonal nut M6
- M300120 Plug-in clip for U-Profile
- M311315 Hexagonal extension nut M6 x 30 mm (optional)
- M311061 Suspension element (optional)

Suspension option D3

- M300166 Combi-Nonius hanger for U-Profile
- - Nonius top part (various lengths)
- M300036 Nonius locking pin
- M300120 Plug-in clip for U-Profile

Suspension option D4

- M300166 Combi-Nonius hanger for U-Profile
- - Eye wire (various lengths)
- M300120 Plug-in clip for U-Profile

Detail B

U-Profile modulation

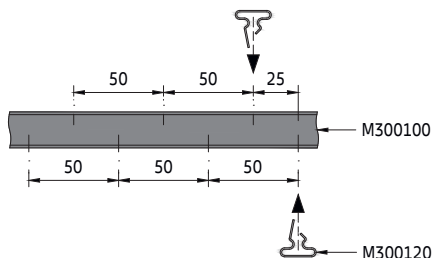

The U-Profile primary grid is a modular system based on a spacing of 50 mm. The holes on the lateral sides are offset from each other by 25 mm. This means that distances of 25 mm can be achieved. Other sizes covered by the long holes.

Example B1

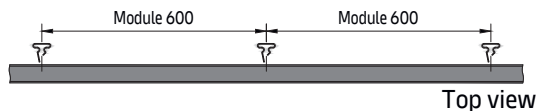

With a module size of e.g. 600 mm, the plug-in clips are always attached to the same side.

Example B2

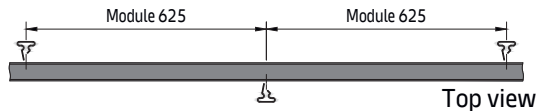

With a module size of e.g. 625 mm, the plug-in clips are attached alternately.

U-Profile

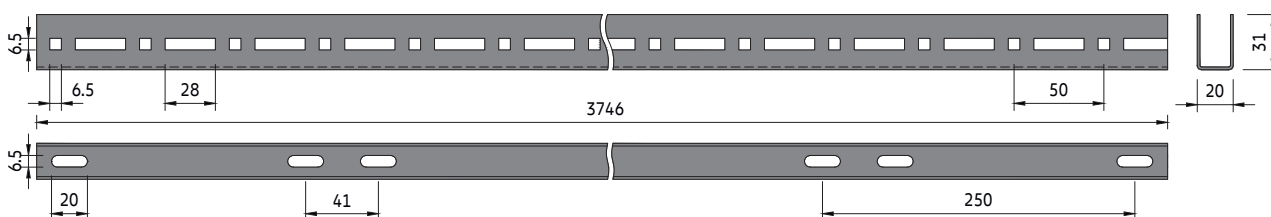

U-Profile Primary Grid C02

Typical grid layout

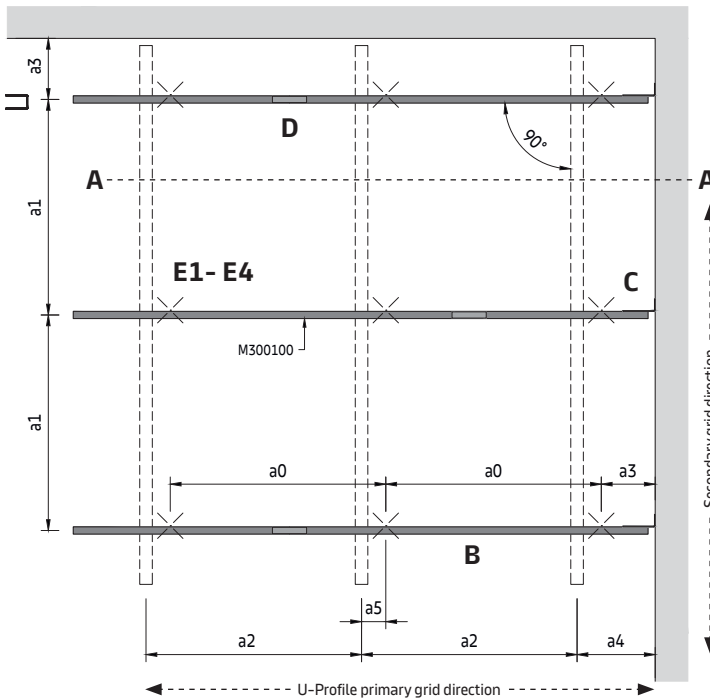

Parameters

- a0 Distance between U-Profile suspension points = max. 1900 mm
- a1 Max. distance between U-Profiles
- a2 Distance between secondary grid
- a3 Distance from wall = max. 200 mm
- a4 Distance from wall = max. panel length
- a5 Distance from U-Profile suspension point to hanger = max. 100mm

The required distances are shown in combination with the secondary grid and will vary depending on the system chosen.

U-Profile alignment

The U-profiles should be installed vertically and on the same level, in a max. distance of (a1).

Installed incorrectly



Installed correctly

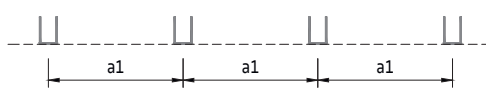

U-Profiles should be aligned with each other in the longitudinal direction, otherwise the module will not be aligned.

Installed incorrectly

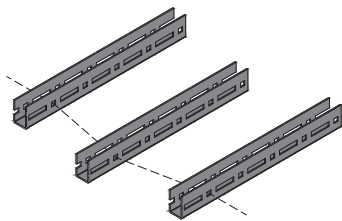

Installed correctly

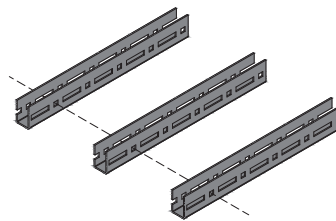

U-Profile Primary Grid

C02

Detail C

Wall fixing

The wall anchor can be attached either to the side (option C1) or below the U-Profile (option C2). It prevents the U-Profile from swinging and thus contributes to the safe installation of the substructure. The wall anchor has no load-bearing function and is only attached to one end of the room to secure the U-Profile. Maintain a small gap between the U-Profile and the wall.

Option C1

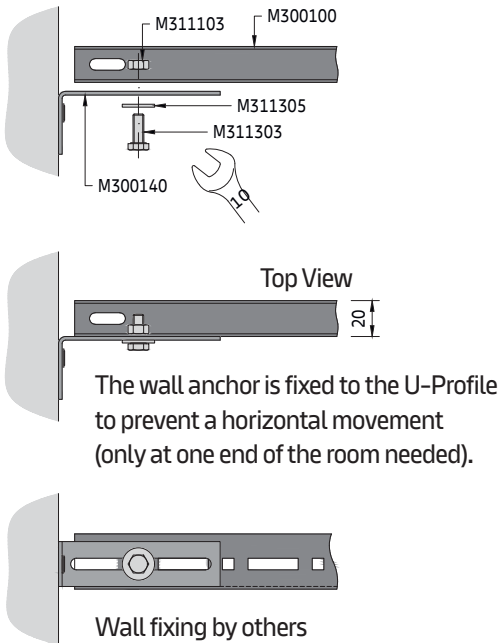

Option C2

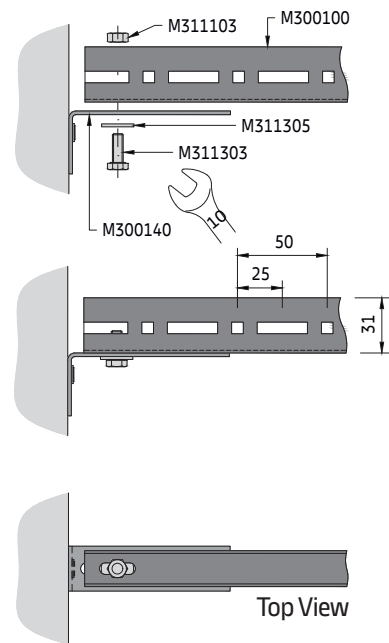

Detail D

Splice connection

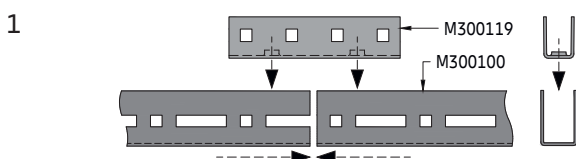

The splice connector for U-Profile comes with two bolts, which must first be removed. The splice connector is then placed between the two ends of the U-Profiles.

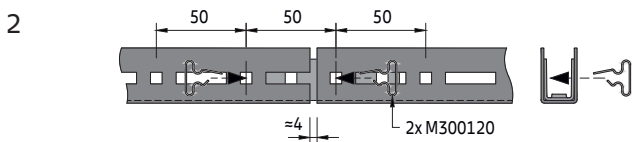

Fix the splice connector with two plug-in clips (large end upwards) at each end. This maintains the modular distance of 50 mm.

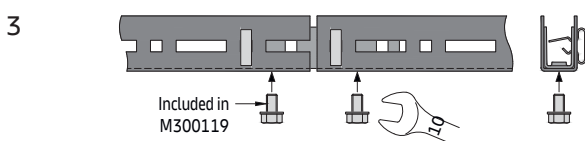

For a stable connection, the two supplied bolts are attached from below.

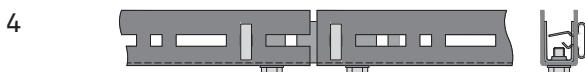

Since the U-Profile is a modular system, the ends must not touch. There is a distance of approx. 4 mm, depending on the length tolerance of the profile. Joints should be offset across the ceiling area.

Detail J

Suspension options

Option E1

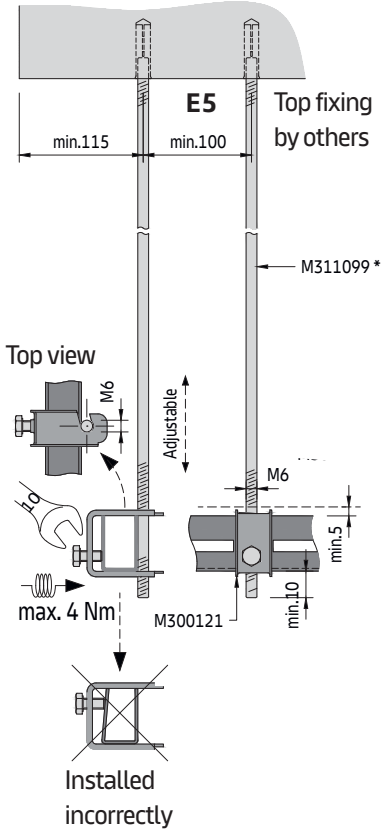

Option E2

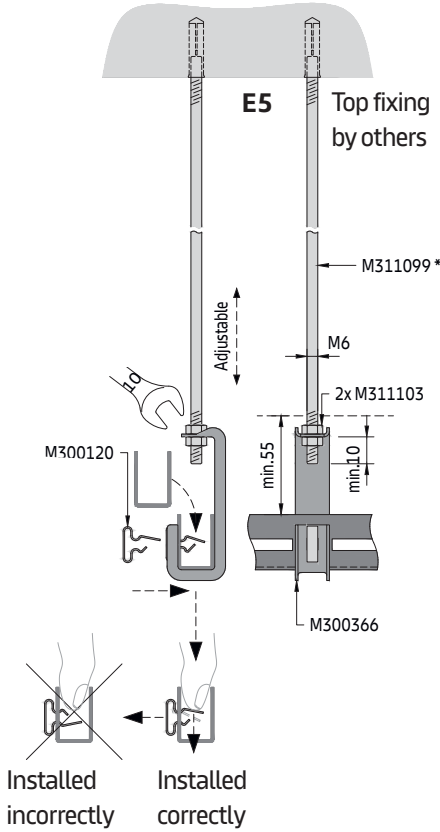

Option E3

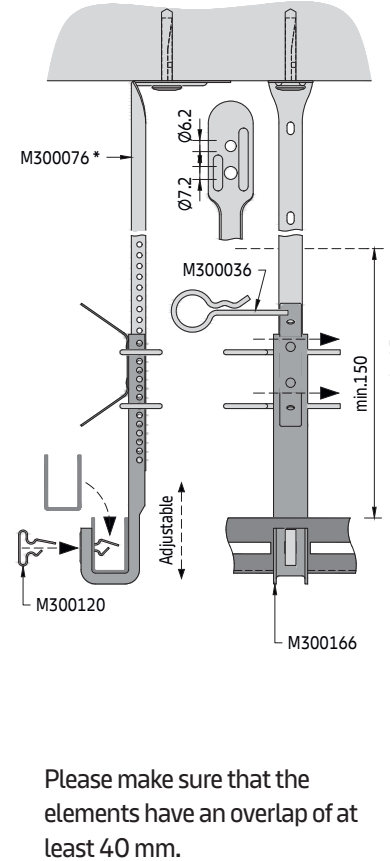

Option E4

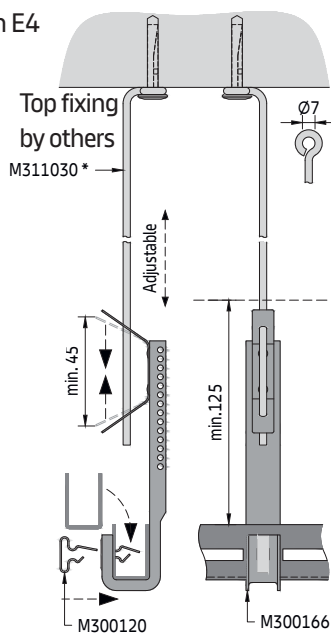

The suspension point should always be chosen close to the crossing point of the primary and secondary grid (a5) in order to absorb the ceiling load as best as possible and to prevent the U-profile from potentially deflecting.

Minimum pull-out force per suspension point = 1.25 kN (failure state)

Maximum permissible load per suspension point = 0.50 kN (incl. 2.5 times safety). These values must always be observed and guaranteed by the installation company for each suspension point irrespective of the type of hanger selected.

Detail E5

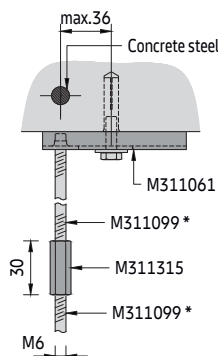

Optional top fixing and extension detail for suspension option E1 / E2

The clip should only be compressed as indicated to avoid possible damage.

* Various lengths available

U-Profile Primary Grid

C02

General installation sequence

- 1 The position of the suspension points must be marked on the soffit before installation (laser, measuring tape, chalk line, etc.). Then drill the holes and place the top fixing (not offered by Knauf Ceiling Solutions).
- 2 Set threaded rods, Nonius top parts or eye wires, shorten if necessary.
- 3 Wherever possible, fixing should begin on the centre axis of the ceiling area.
- 4 Align the wall angle with the laser (lower edge of the visible side of the ceiling components) and attach to the perimeter walls.
- 5 Suspension options:
 - E1** - Fasten the U-Profile to the threaded rod using a clamping bracket and align the height.
 - E2** - Align the height of the U-Profile hanger and fasten it to the threaded rod with two hexagonal nuts, then hang in the U-profile and fix the position with plug-in clips.
 - E3** - Align the height of the combi-Nonius hanger and fasten it to the Nonius top-part with two safety clips, then hang in the U-profile and fix the position with plug-in clips.
 - E4** - Align the height of the combi-Nonius hanger and fasten it to the eye wire, then hang in the U-profile and fix the position with plug-in clips.The minimum installation height is depending on the selected suspension option **E1 - E4**.
- 6 U-Profiles should be aligned with each other in the longitudinal direction and joints should be offset. Couple the U-Profiles with splice connectors and fix them to the perimeter walls with the wall anchor at one end of each row of U-Profiles.
- 7 See secondary grid pages for further steps.
- 8 Lay full ceiling elements, followed by cut or full perimeter elements.
- 9 Service integrations and additional loads must be suspended separately from the soffit. The additional measures must be carried out professionally.

U-Profile Primary Grid C02

U-Profile bridging carrier

The U-Profile bridging carrier option has been designed as a single or continuous solution for smaller areas where direct suspension from the soffit is not possible with standard spacing. It is based on the standard U-Profile installation. The bridging carrier can either be added to the standard primary grid structure or installed on top of it as an additional layer. Use on large areas is not recommended as assembly is time consuming, but still quicker than leaving the job site for another solution. The connector and bolts can be stored in the tool box. This means that you always have a quick and easy solution to hand when you need it. When planning, it is important to ensure that the connectors are positioned so that they do not interfere with the suspension point (**E1**) nor the hanger for the secondary grid. The distance between the connectors (a_9) and to the suspension point (a_{10}) must not be exceeded.

Isometric view

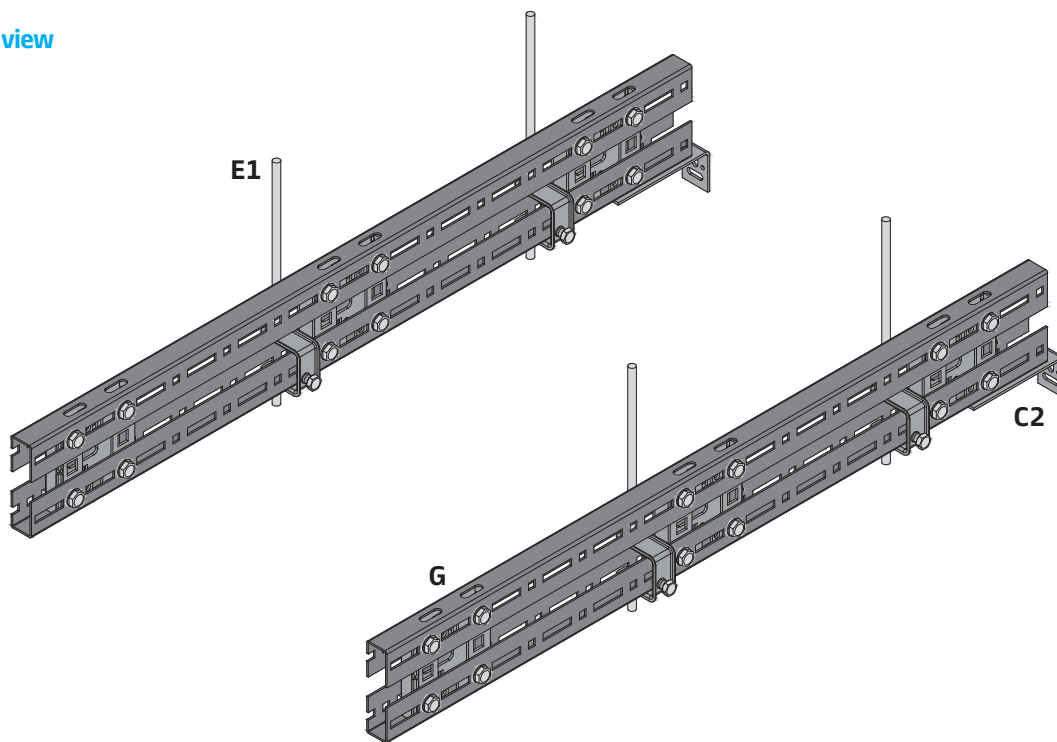

Single bridging carrier

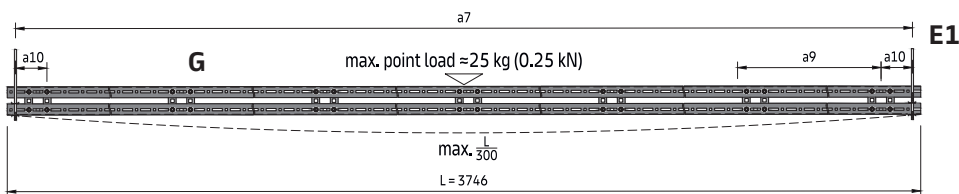

Continuous bridging carrier

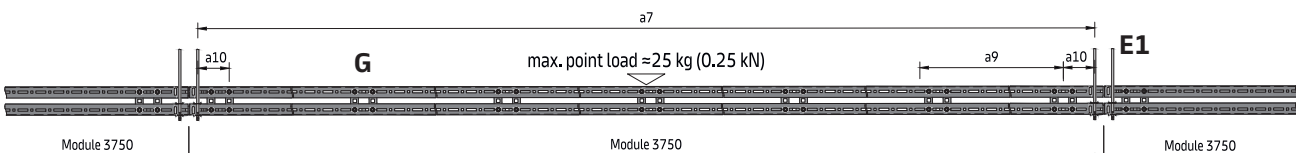

U-Profile Primary Grid

C02

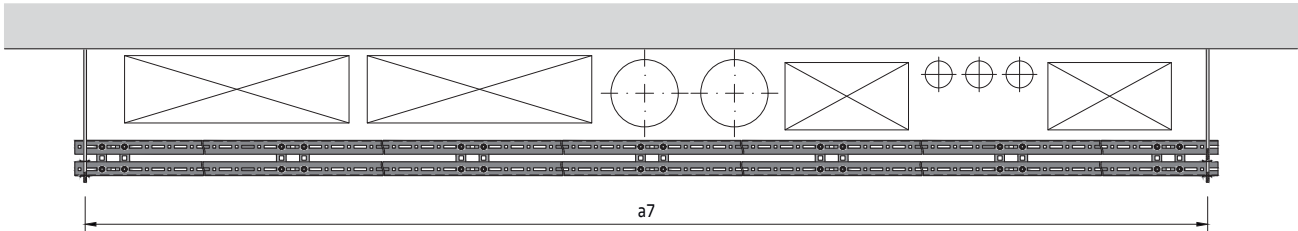
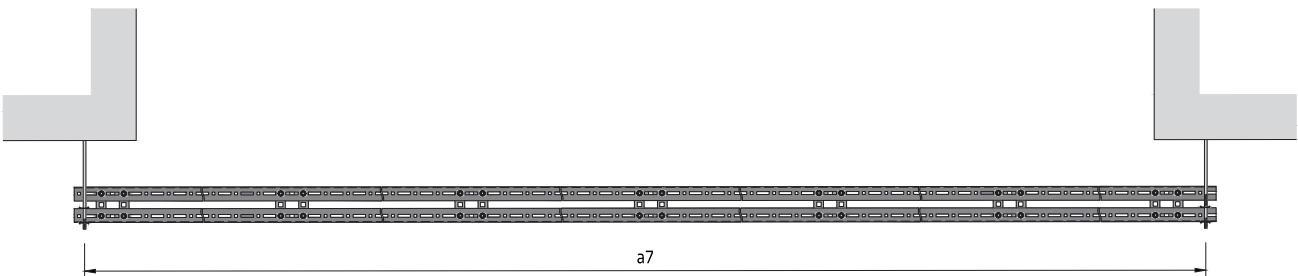
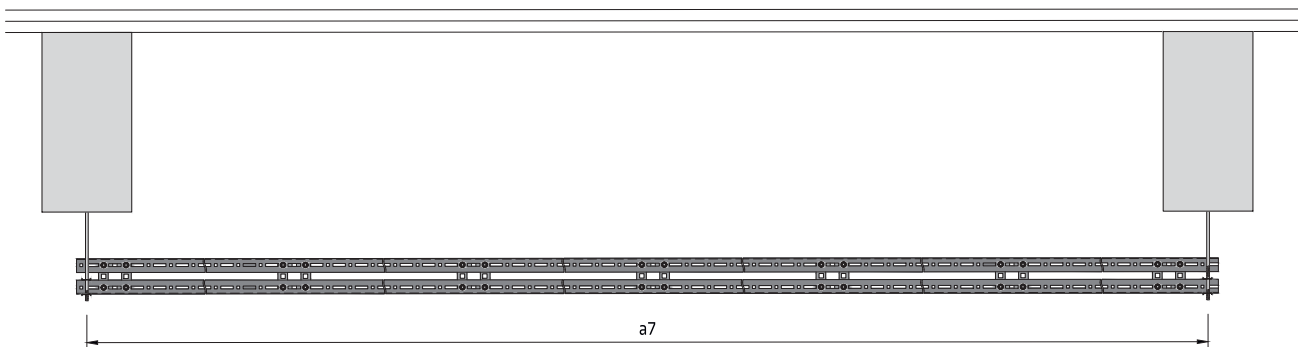
Application area 1**No fixation possible, due to building equipment****Application area 2****No fixation possible, due to ceiling aperture****Application area 3****No fixation possible, except on beams****U-Profile bridging carrier components****Standard components**

- M300101 Connector for U-Profile bridging carrier
- M311195 Thread cutting bolt M6 x 10 mm

U-Profile Primary Grid

C02

Spacing for DP12 A-Bar / L-Profile

a7 [mm]	System without additional load		System with additional load +4 kg/m ²	
	a8 [mm]	a8 [mm]	a8 [mm]	a8 [mm]
2800	1900		1900	
2900	1900		1900	
3000	1900		1800	
3100	1900		1650	
3200	1900		1500	
3300	1900		1350	
3400	1900		1250	
3500	1750		1150	
3600	1600		1050	
3700	1500		950	

Spacing for Spring-T / J-Bar

a7 [mm]	System without additional load		System with additional load +4 kg/m ²	
	a8 [mm]	a8 [mm]	a8 [mm]	a8 [mm]
2800	1900		1900	
2900	1900		1900	
3000	1900		1750	
3100	1900		1550	
3200	1900		1400	
3300	1900		1300	
3400	1800		1200	
3500	1650		1100	
3600	1500		1000	
3700	1400		900	

Spacing for H-Profile 28 / H-Profile 35

a7 [mm]	System without additional load		System with additional load +4 kg/m ²	
	a8 [mm]	a8 [mm]	a8 [mm]	a8 [mm]
2800	1900		1900	
2900	1900		1900	
3000	1900		1800	
3100	1900		1700	
3200	1900		1550	
3300	1900		1400	
3400	1900		1250	
3500	1850		1150	
3600	1700		1050	
3700	1550		1000	

Spacing for C-Profile / Bandraester

a7 [mm]	System without additional load		System with additional load +4 kg/m ²	
	a8 [mm]	a8 [mm]	a8 [mm]	a8 [mm]
2800	1900		1900	
2900	1900		1750	
3000	1900		1550	
3100	1900		1400	
3200	1850		1300	
3300	1700		1150	
3400	1550		1050	
3500	1400		1000	
3600	1300		900	
3700	1200		850	

U-Profile Primary Grid

C02

Typical grid layout

Bridging carrier as part of the U-Profile primary grid

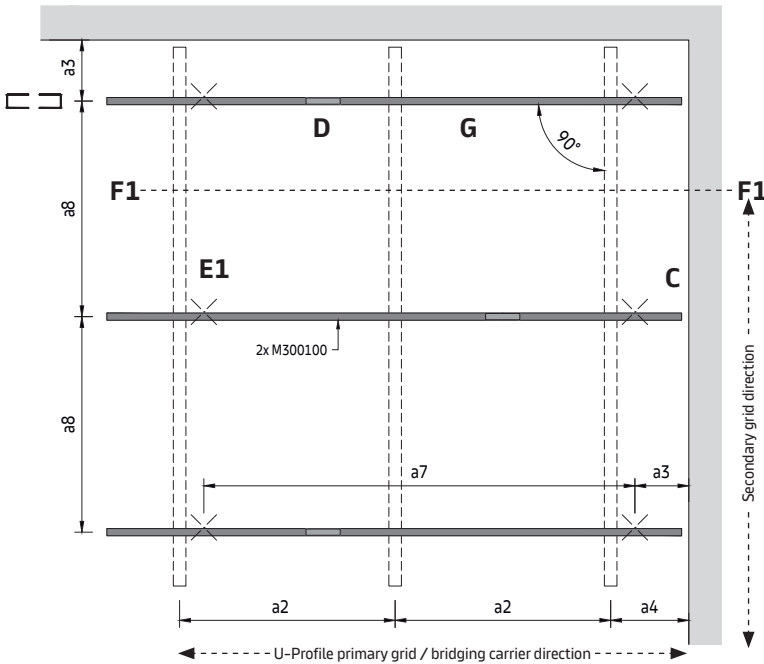

Bridging carrier as additional layer above the U-Profile primary grid

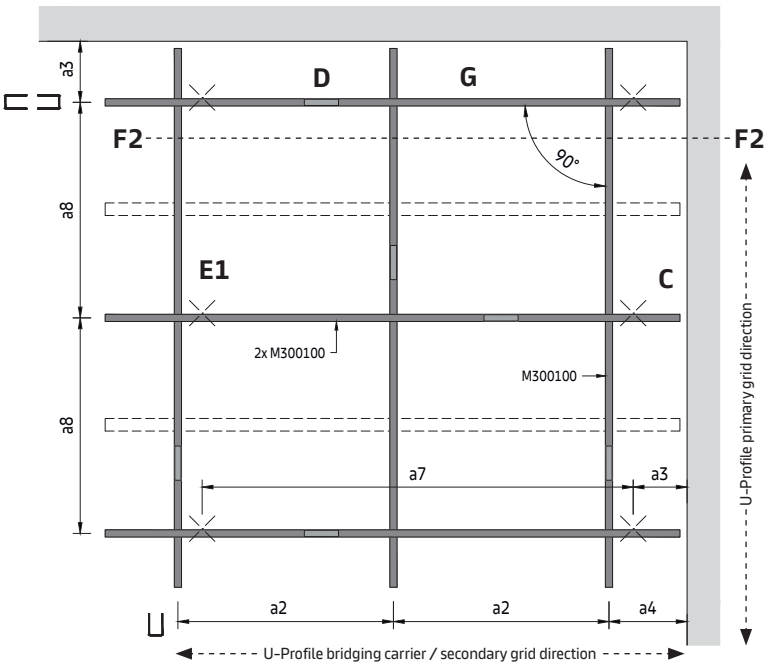

Parameters

- a7 Distance between U-Profile bridging carrier suspension points = max. 3700 mm
- a8 Max. distance between U-Profiles bridging carriers
- a9 Distance between U-Profile bridging carrier connectors = max. 600 mm
- a10 Distance between U-Profile suspension point and connector = max. 100 mm

U-Profile Primary Grid

C02

Section F1

Bridging carrier as part of the U-Profile primary grid

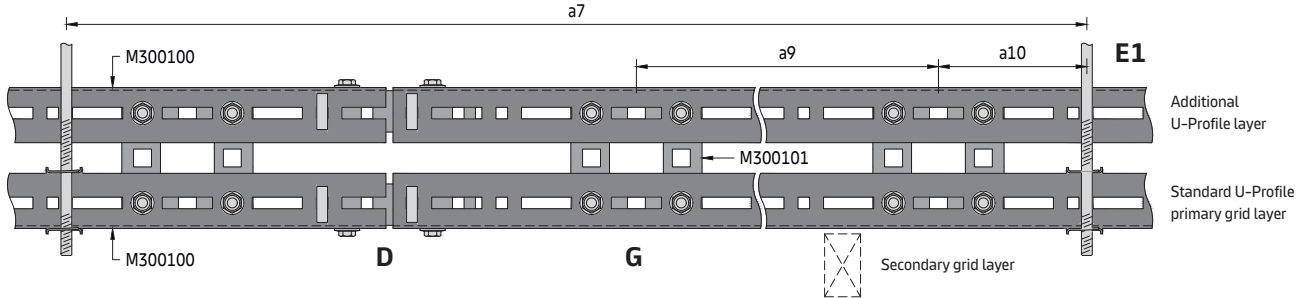

With this option, the U-Profile is reinforced with a second one above it. The secondary grid below is installed as in the standard installation.

Section F2

Bridging carrier as additional layer above the U-Profile primary grid

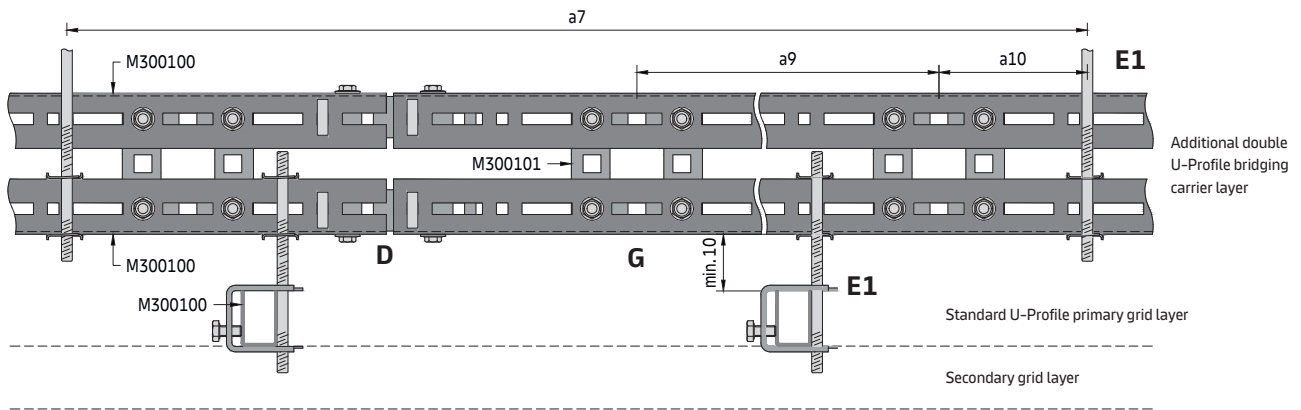

With this option, the U-Profile primary grid and the secondary grid are installed as in the standard installation. Additionally, a U-Profile bridging carrier layer is added above.

Detail G Connector

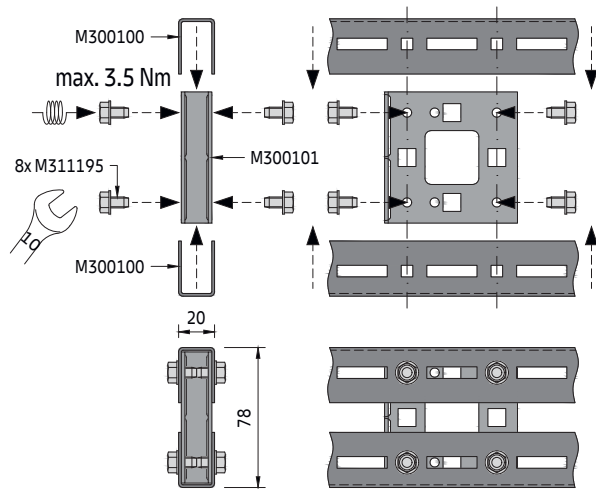
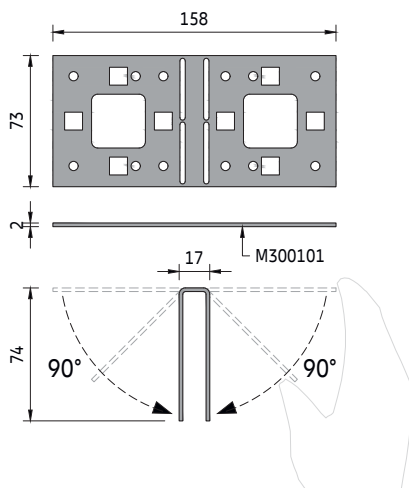

The connector is supplied as a flat piece, which saves space, and is hand bent into a U-shape before installation.

Place the connector between the two U-Profile layers and connect it with the thread cutting bolts. In order to create a stable connection, 8 bolts are required per connector.



12:09

C-CHANNEL PRIMARY GRID

Primary grid solution for indoor applications

General information

- Primary grid concept for small, medium and large rooms, with a minimum number of components
- For perpendicular installation with secondary grid
- All standard items are held in stock
- Tried and tested solution

Isometric view

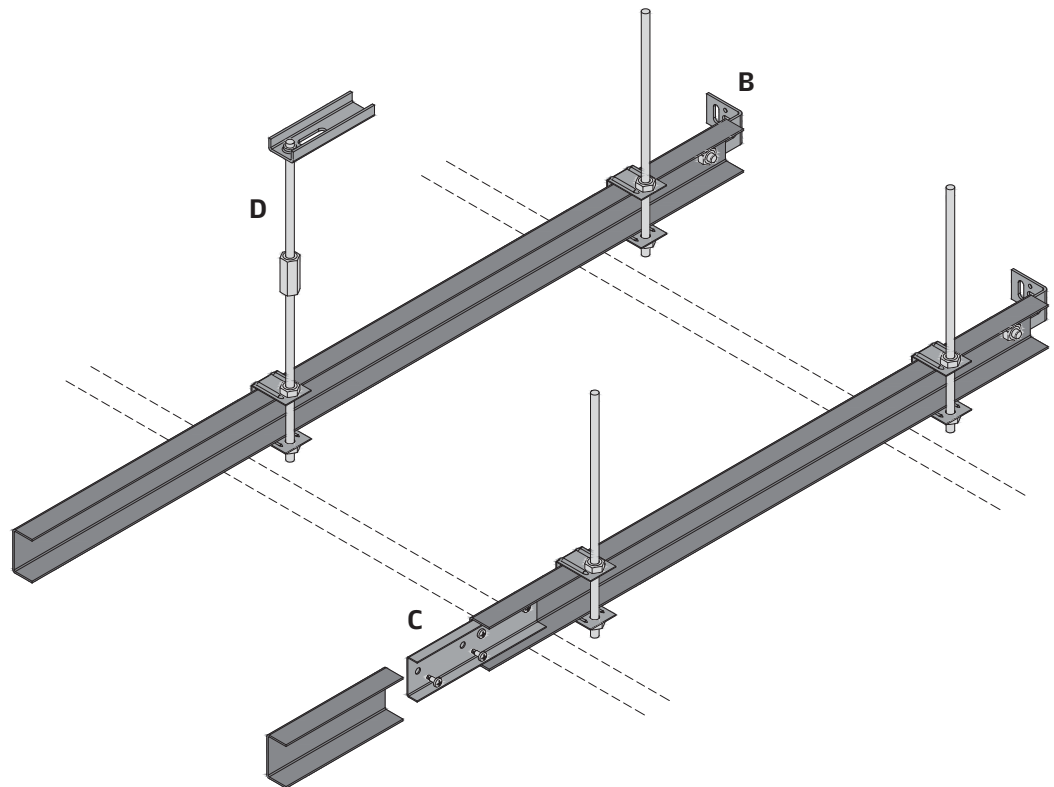

Important information

The C-Channel system fulfils the two conditions required in the European standard (EN 13964) concerning load-bearing capacity (2.5 times the failure criterion) and performance capability (deflection restriction).

Section A

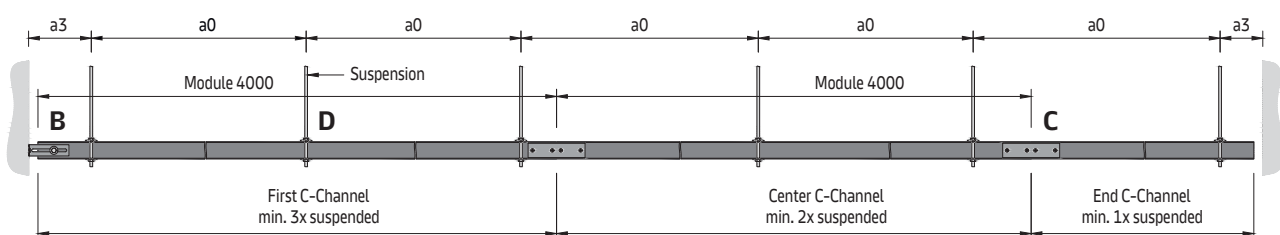

C-Channel Primary grid C03

Typical grid layout

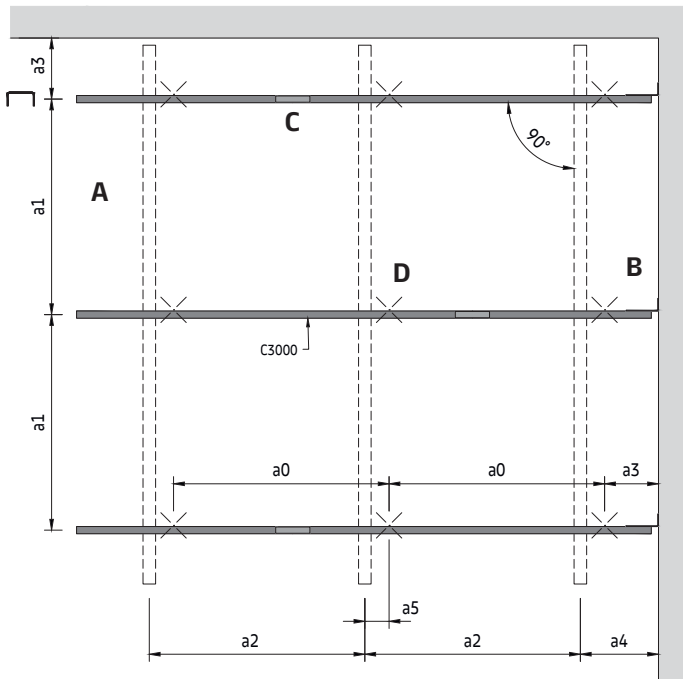

Parameters

- a0 Distance between C-Channel suspension points = max. 1900 mm
- a1 Max. distance between C-Channels
- a2 Distance between secondary grid
- a3 Distance from wall = max. 200 mm
- a4 Distance from wall = max. panel length
- a5 Distance from C-Channel suspension point to hager = max. 100 mm

The required distances are shown in combination with the secondary grid and will vary depending on the system chosen.

Primary grid components

Standard components

- C3000 C-Channel
- C7140 Splice connector for C-Channel
- M300140 Wall anchor
- CA97 Clamping bracket for C-Channel
- M311103 Hexagonal nut M6
- M311105 Washer
- M311303 Hexagonal bolt M6 x 16 mm
- M311101 Threaded rod M6 x 1000 mm
- M311315 Hexagonal extension nut M6 x 30 mm (optional)
- M311061 Suspension element (optional)

C-Channel

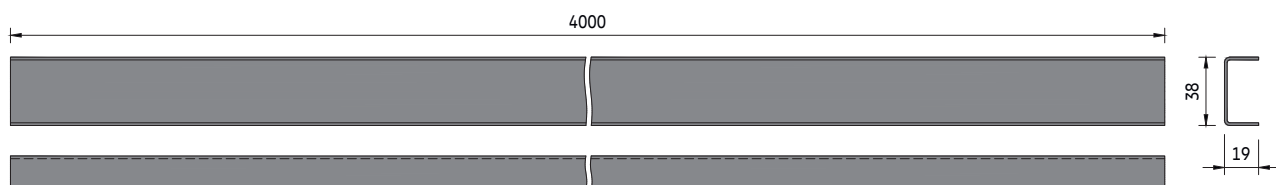

C-Channel Primary grid C03

C-Channel alignment

The C-Channels should be installed vertically, level and evenly spaced (a1).

Installed incorrectly



Installed correctly

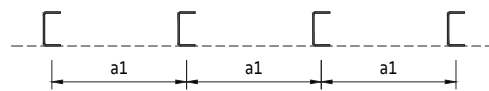

Detail B

Wall fixing

Option 1

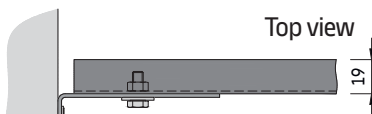
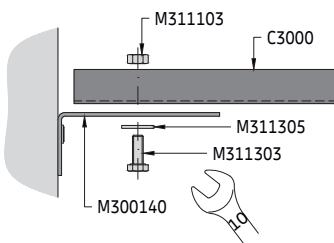

The wall anchor is fixed to the C-Channel to prevent horizontal movement (only necessary at one end of the run)

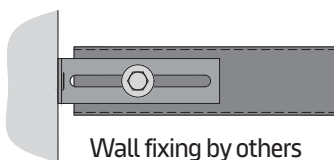

Option 2

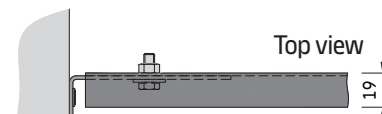
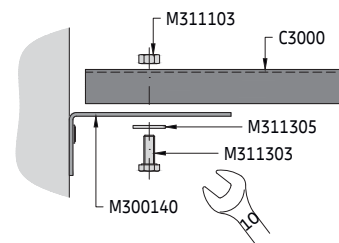

The wall anchor can be attached in two different ways to the C-Channel (option B1 / B2). It prevents the C-Channel from swinging and thus contributes to the safe installation of the substructure. The wall anchor has no load-bearing function and is only attached to one end of the room to secure the C-Channel. Maintain a gap between the end of the C-Channel and the wall, ≈10 mm.

Detail C

Splice connection

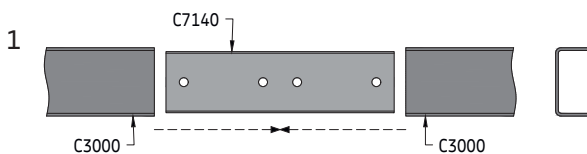

The splice connector is placed between the two ends of the C-Channels ensuring the C-Channels are butted together.

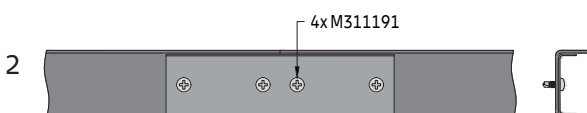

Fix the splice connector with four self-drilling screws.

C-Channel Primary grid C03

Detail D

Suspension detail

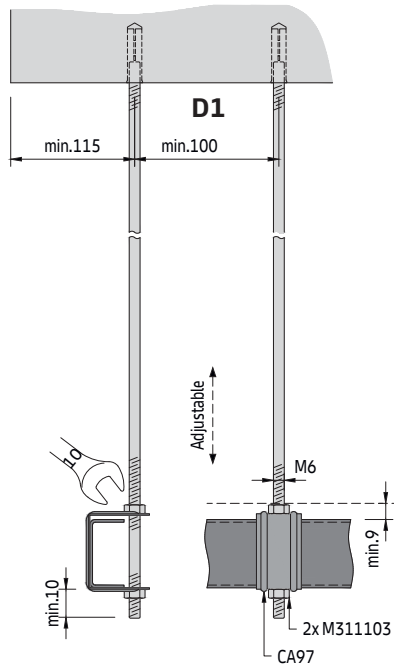

Detail D1

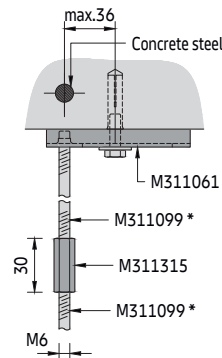

Optional top fixing and extension detail

The suspension point should always be chosen close to the crossing point of the primary and secondary grid (a5) in order to support the ceiling load as best as possible and to prevent the C-Channel from potentially deflecting.

Minimum pull-out force per suspension point = 1.25 kN (failure state)

Maximum permissible load per suspension point = 0.50 kN (incl. 2.5 times safety). These values must always be observed and guaranteed by the installation company for each suspension point irrespective of the type of hanger selected.

General installation sequence

- 1 The position of the suspension points must be marked on the soffit before installation (laser, measuring tape, chalk line, etc.). Then drill the holes and place the top fixing (not offered by Knauf Ceiling Solutions).
- 2 Set threaded rods, shorten if necessary.
- 3 Wherever possible, fixing should begin on the centre axis of the ceiling area.
- 4 Align the wall angle with the laser (lower edge of the visible side of the ceiling components) and attach to the perimeter walls.
- 5 Fasten the C-Channel to the threaded rod using a clamping bracket and align the height.
- 6 C-Channel should be aligned with each other and joints should be offset. Couple the C-Channel with splice connectors and fix them to the boundary walls with the wall anchor at one end of each row of C-Channel.
- 7 See secondary grid pages for further steps.
- 8 Install full ceiling elements, followed by cut or full perimeter elements.
- 9 Service integrations and additional loads must be suspended from the soffit independently.

PRIMARY ANGLE PRIMARY GRID

Primary grid solution for indoor applications

General information

- Primary grid concept for small, medium and large rooms, with a minimum number of components
- Two options of primary angle available
- For installation with secondary grid
- All standard items are held in stock
- Tried and tested solution with extensive experience

Isometric view

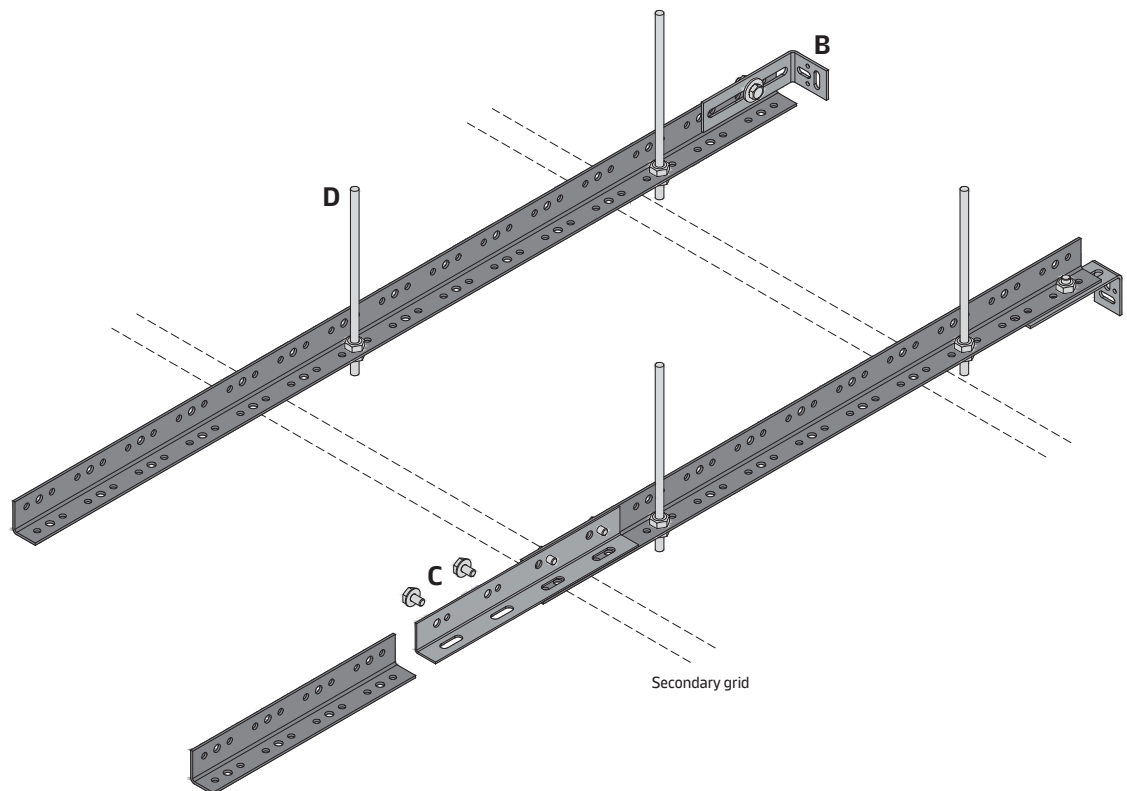

Important information

The primary angle system fulfils the two conditions required in the European standard (EN 13964) concerning load-bearing capacity (2.5 times the failure criterion) and performance capability (deflection restriction).

Section A

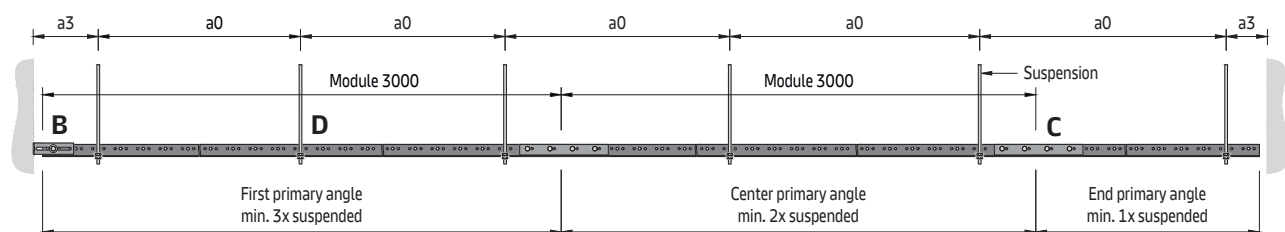

Primary Angle Primary Grid

C04

Typical grid layout

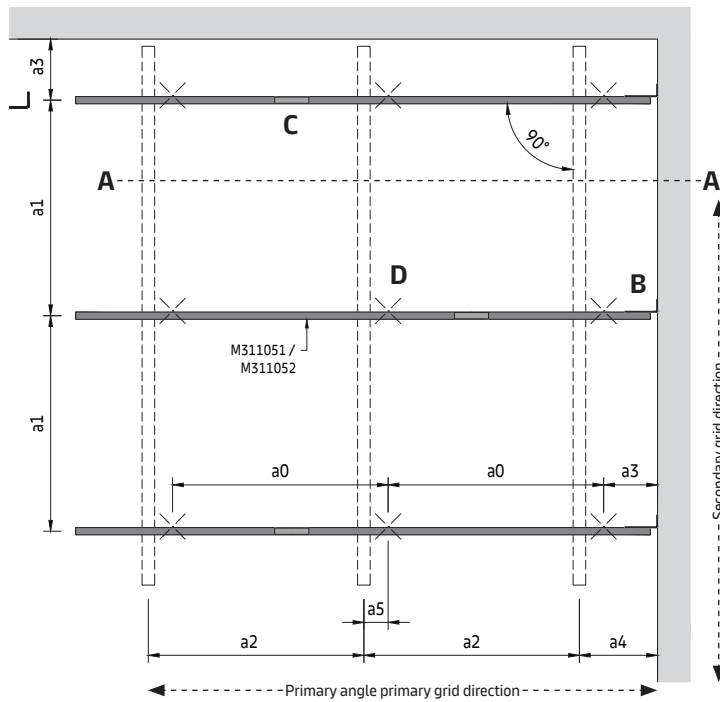

Parameters

- a0 Distance between primary angle suspension points = max. 1900 mm
- a1 Max. distance between primary angles
- a2 Distance between secondary grid
- a3 Distance from wall = max. 200 mm
- a4 Distance from wall = max. panel length
- a5 Distance from primary angle suspension point to hanger = max. 100 mm

The required distances are shown in combination with the secondary grating and will vary depending on the system chosen.

Primary angle 27 x 22 mm

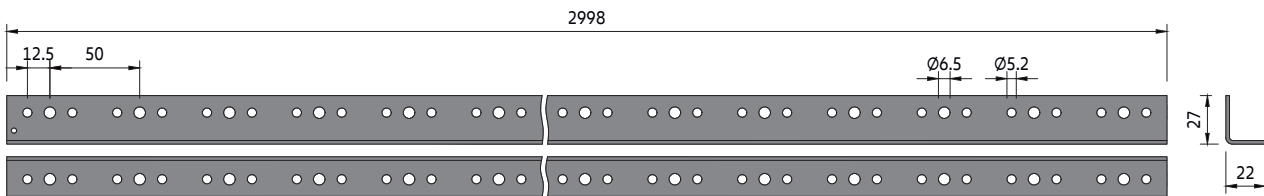

Primary angle 50 x 22 mm

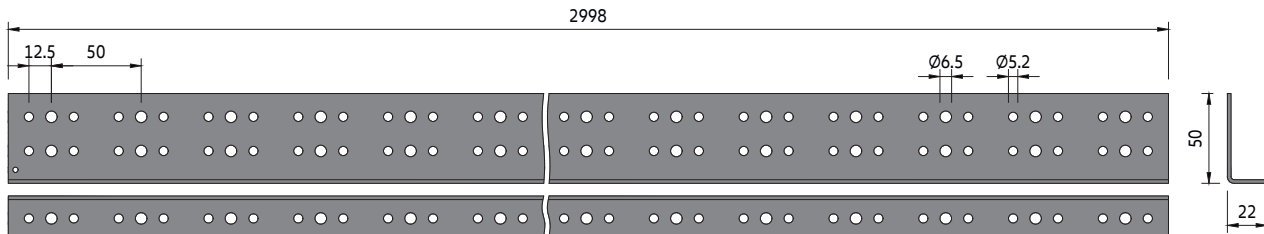

Primary Angle Primary Grid C04

Primary angle alignment

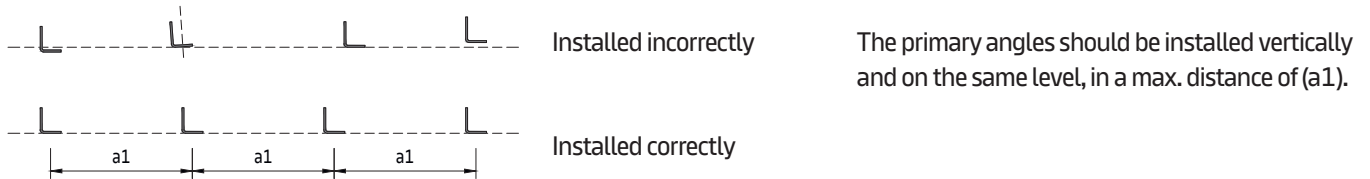

Detail B

Wall fixing

The wall anchor can be attached in two different ways to the primary angle (option B1 / B2). It prevents the primary angle from swinging and thus contributes to the safe installation of the substructure.

The wall anchor has no load-bearing function and is only attached to one end of the room to secure the primary angle. Keep some distance from the primary angle to the wall.

Option B1

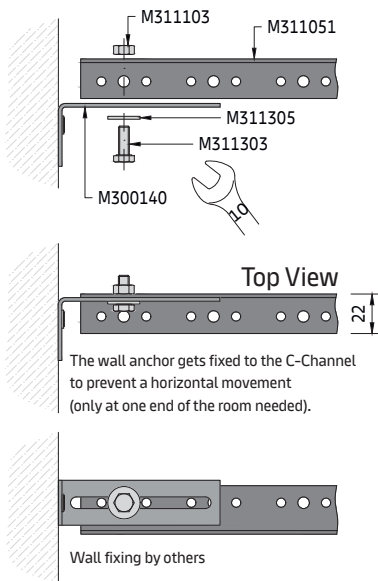

Option B2

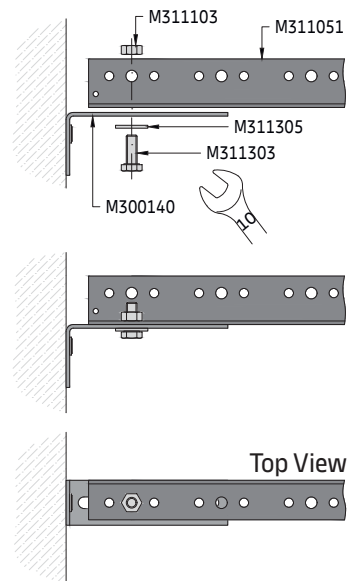

Detail C

Splice connection

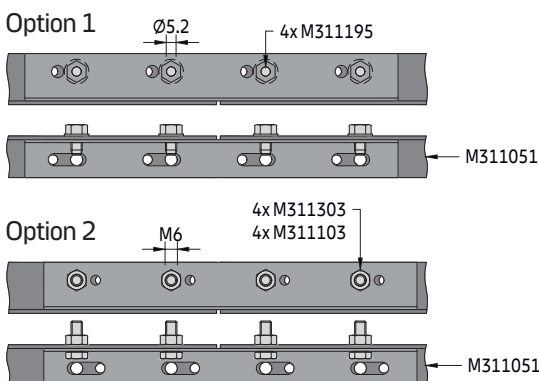

The splice connector is placed between the two ends of the primary angles. It was designed in such a way that the threaded rod can always be placed, even when there is a splice connector.

Option 1

Take four thread cutting screws and fix the splice connector to the primary angles. Use the smaller holes.

Option 2

Take four M6 bolts and nuts and fix the splice connector to the primary angles. Use the bigger M6 holes.

Primary Angle Primary Grid

C04

Primary grid components**Standard components**

- M311051 Primary angle 27 x 22 mm
- M311052 Primary angle 50 x 22 mm
- M311053 Splice connector for primary angle
- M300140 Wall anchor
- M311103 Hexagonal nut M6
- M311105 Washer
- M311303 Hexagonal bolt M6 x 16 mm
- M311195 Thread cutting screw M6 x 10 mm
- M311101 Threaded rod M6 x 1000 mm
- M311315 Hexagonal extension nut M6 x 30 mm (optional)
- M311061 Suspension element (optional)

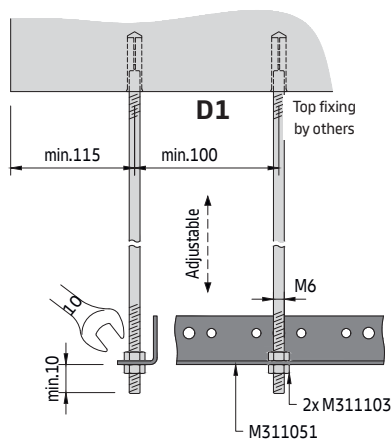
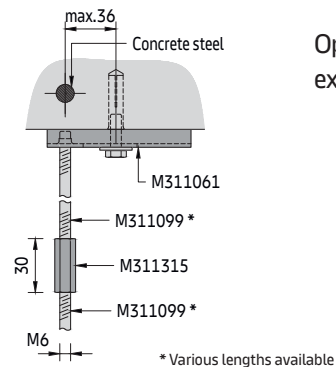
Detail D**Suspension detail****Detail D1**

Optional top fixing and extension detail

The suspension point should always be chosen close to the crossing point of the primary and secondary grid (a5) in order to absorb the ceiling load as best as possible and to prevent the primary angle from potentially deflecting.

Minimum pull-out force per suspension point = 1.25 kN (failure state)

Maximum permissible load per suspension point = 0.50 kN (incl. 2.5 times safety). These values must always be observed and guaranteed by the installation company for each suspension point irrespective of the type of hanger selected.

General installation sequence

- 1 The position of the suspension points must be marked on the soffit before installation (laser, measuring tape, chalk line, etc.). Then drill the holes and place the top fixing (not offered by Knauf Ceiling Solutions).
- 2 Set threaded rods, cut to length if necessary.
- 3 Wherever possible, fixing should begin on the centre axis of the ceiling area.
- 4 Align the wall angle with the laser (lower edge of the visible side of the ceiling components) and attach to the boundary walls.
- 5 Fasten the primary angle to the threaded rod using two hexagonal nuts and align the height.
- 6 Primary angle should be aligned with each other and joints should be offset. Couple the primary angles with splice connectors and fix them to the boundary walls with the wall anchor at one end of each row of primary angle.
- 7 See secondary grid pages for further steps.
- 8 Lay full ceiling elements, followed by cut or full perimeter elements.
- 9 Service integrations and additional loads must be suspended separately from the soffit. The additional measures must be carried out professionally.

DP12 A-BAR PRIMARY GRID

Primary grid solution for indoor applications

General information

- Primary grid concept for small, medium and large rooms, with a minimum number of components
- For perpendicular double layer installation with DP12 A-Bar secondary grid
- All standard items are held in stock
- Tried and tested solution with extensive experience

Isometric view

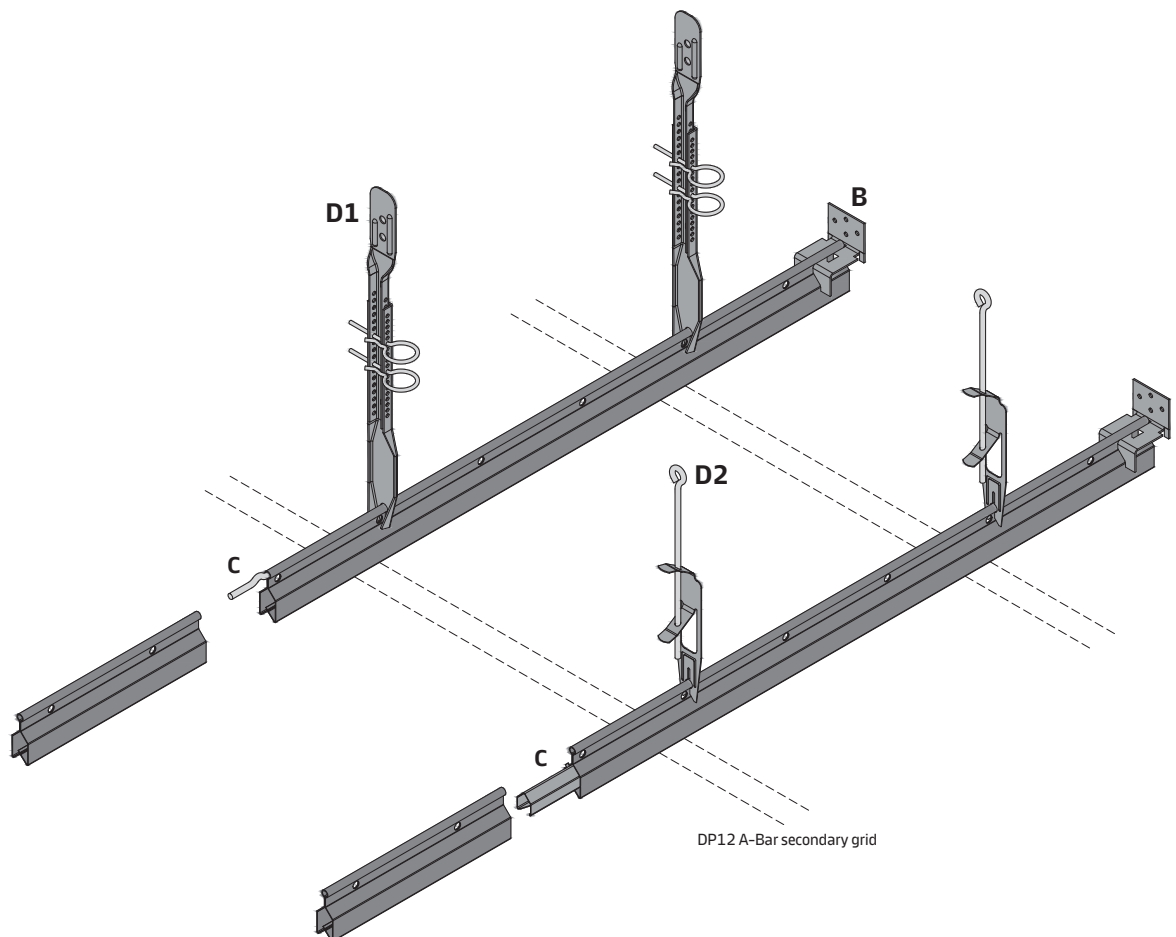

Important information

The DP12 A-Bar system fulfils the two conditions required in the European standard (EN 13964) concerning load-bearing capacity (2.5 times the failure criterion) and performance capability (deflection restriction).

DP12 A-Bar Primary Grid C05

Section A

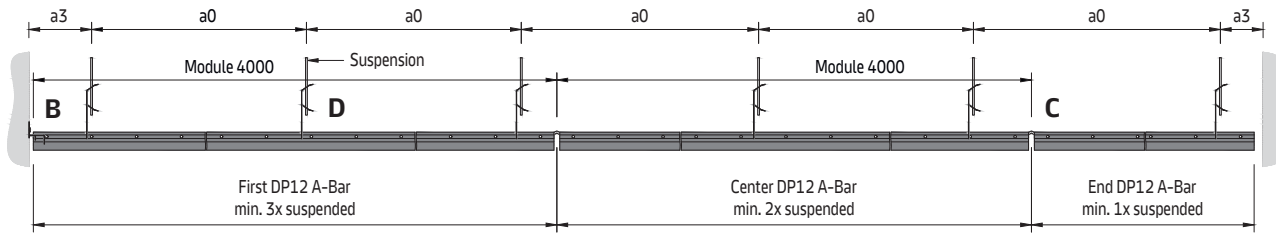

Typical grid layout

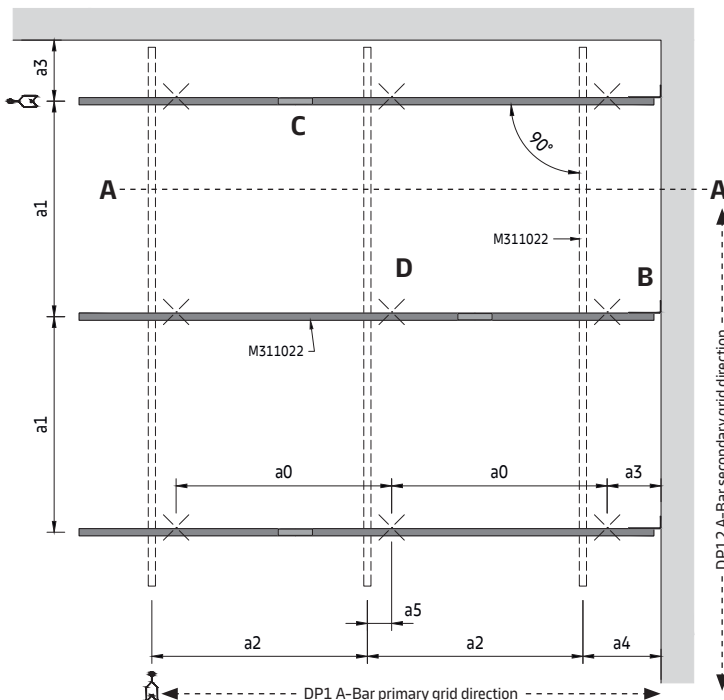

Parameters

- a0 Distance between DP12 A-Bar suspension points = max. 1900 mm
- a1 Max. distance between DP12 A-Bar
- a2 Distance between secondary grid
- a3 Distance from wall = max. 200 mm
- a4 Distance from wall = max. panel length
- a5 Distance from DP12 A-Bar suspension point to hanger = max. 100 mm

The required distances are shown in combination with the secondary grid and will vary depending on the system chosen.

Primary grid components

Standard components

- M311022 DP12 A-Bar
- M300138 Connection pin for DP12 A-Bar
- M311024 Wall anchor for DP12

Suspension option D1

- M311338 Nonius hanger for DP12 A-Bar
- - Nonius top part (various lengths)
- M300036 Nonius locking pin

Suspension option D2

- M311026 Rapid hanger for DP12 A-Bar
- - Eye wire (various lengths)

Optional components

- M311023 Splice connector for DP12 A-Bar

DP12 A-Bar

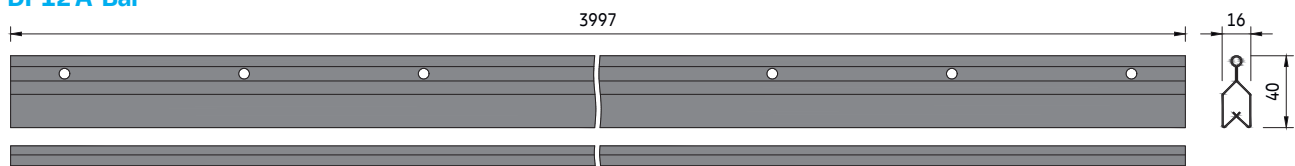

DP12 A-Bar Primary Grid C05

DP12 A-Bar alignment

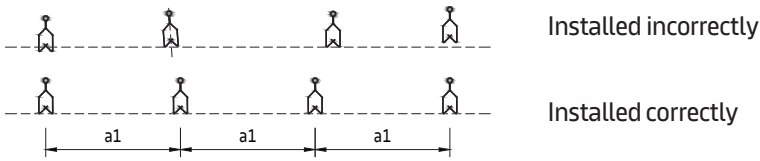

The DP12 A-Bars should be installed vertically and on the same level, in a max. distance of (a1).

Detail B

Wall fixing

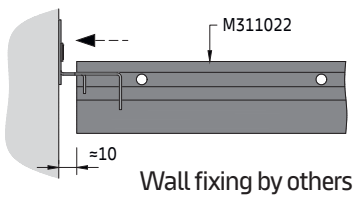
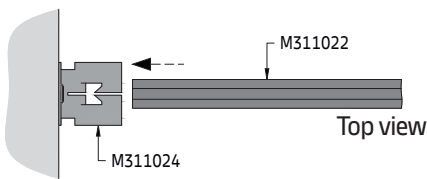

The wall anchor gets fixed to the DP12 A-Bar to prevent a horizontal movement (only at one end of the room needed).

The wall anchor prevents the DP12 A-Bar from swinging and thus contributes to the safe installation of the substructure. The wall anchor has no load-bearing function and is only attached to one end of the room to secure the DP12 A-Bar. Slide the DP12 A-Bar into the wall anchor and keep some distance to the wall.

Detail C

Splice connection

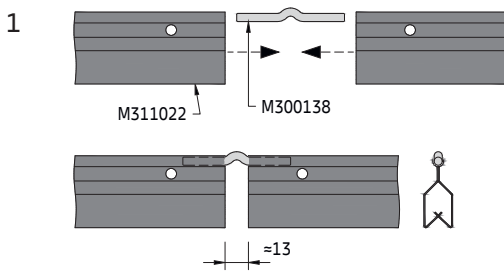

Insert the connection pin at the ends of the DP12 A-Bars and connect them. There is a gap between the DP12 A-Bars. The DP12 A-Bars must be aligned so that the joint is not in the same place as the pips on the tiles.

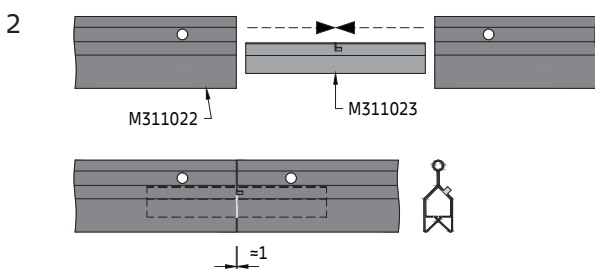

Optionally, the splice connector for DP12 A-Bar can be used. This is inserted at the ends of the DP12 A-Bars and an almost seamless connection is created.

DP12 A-Bar Primary Grid C05

Detail D

Suspension options

Option D1

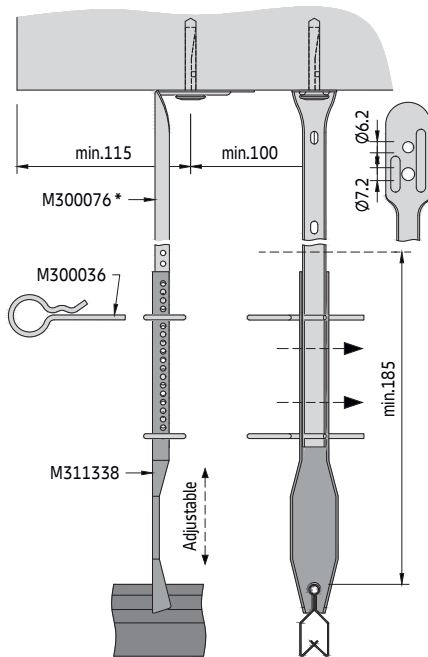

The suspension point should always be chosen close to the crossing point of the primary and secondary grid (a5) in order to absorb the ceiling load as best as possible and to prevent the DP12 A-Bar from potentially deflecting.

Minimum pull-out force per suspension point = 1.25 kN (failure)
Maximum permissible load per suspension point = 0.50 kN (incl. 2.5 times safety).

These values must always be observed and guaranteed by the installation company for each suspension point irrespective of the type of hanger selected.

*Various lengths available

Option D2

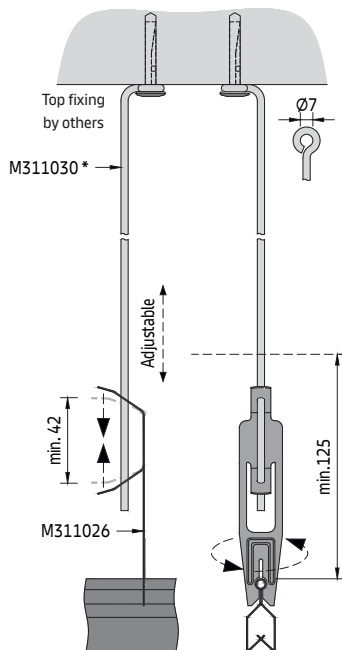

The clip should only be compressed as indicated to avoid possible damage.

DP12 A-Bar Primary Grid

C05

General installation sequence

- 1 The position of the suspension points must be marked on the soffit before installation (laser, measuring tape, chalk line, etc. Then drill the holes and place the top fixing (not offered by Knauf Ceiling Solutions).
- 2 Set Nonius top parts or eye wires.
- 3 Wherever possible, fixing should begin on the centre axis of the ceiling area.
- 4 Align the wall angle with the laser (lower edge of the visible side of the ceiling components) and attach to the boundary wall
- 5 Suspension options:
 - D1** - Position the Nonius bottom part on the DP12 A-Bar and fasten it to the Nonius top-part with two safety clips.
 - D2** - The rapid hanger for DP12 A-Bar is made of spring steel and is therefore elastic. It is twisted on the DP12 A-Bar from above. Position the rapid hanger on the DP12 A-Bar and fasten it to the eye wire.
- 6 The minimum installation height is depending on the selected suspension option **E1 - E2**. DP12 A-Bars should be aligned with each other and joints should be offset. Couple the DP12 A-Bars with splice connectors or connection pins and fix them the boundary walls with the wall anchor at one end of each row of DP12 A-Bars.
- 7 See secondary grid pages for further steps.
- 8 Lay full ceiling elements, followed by cut or full perimeter elements.
- 9 Service integrations and additional loads must be suspended separately from the soffit. The additional measures must be carried out professionally

QI química inorgânica
QO química orgânica
-(p1)

AAA direção/apoio administrativo
UAAT unidade de apoio técnico
MB microbiologia
Ra recepção de amostras
áreas técnicas

(p-1) estacionamento privado
armazém
arquivo documental
áreas técnicas







***Exposed
Grid Ceilings***

METAL Board / METAL Axial Vector METAL MicroLook / METAL Tegular

15 or 24 mm T-Grid

Exposed grid solution for indoor applications

General information

- Exposed lay-in grid system for small, medium and large rooms
- Typical ceiling weight 5.0 kg/m² (indicative value for unperforated tiles, without additional load)
- Tiles are easily installed and fully demountable
- Systems can be installed with hold down clips to prevent movement
- Seismic design application available, see separate document

Isometric view

Select the suspension option.

Perimeter solutions on separate datasheet.

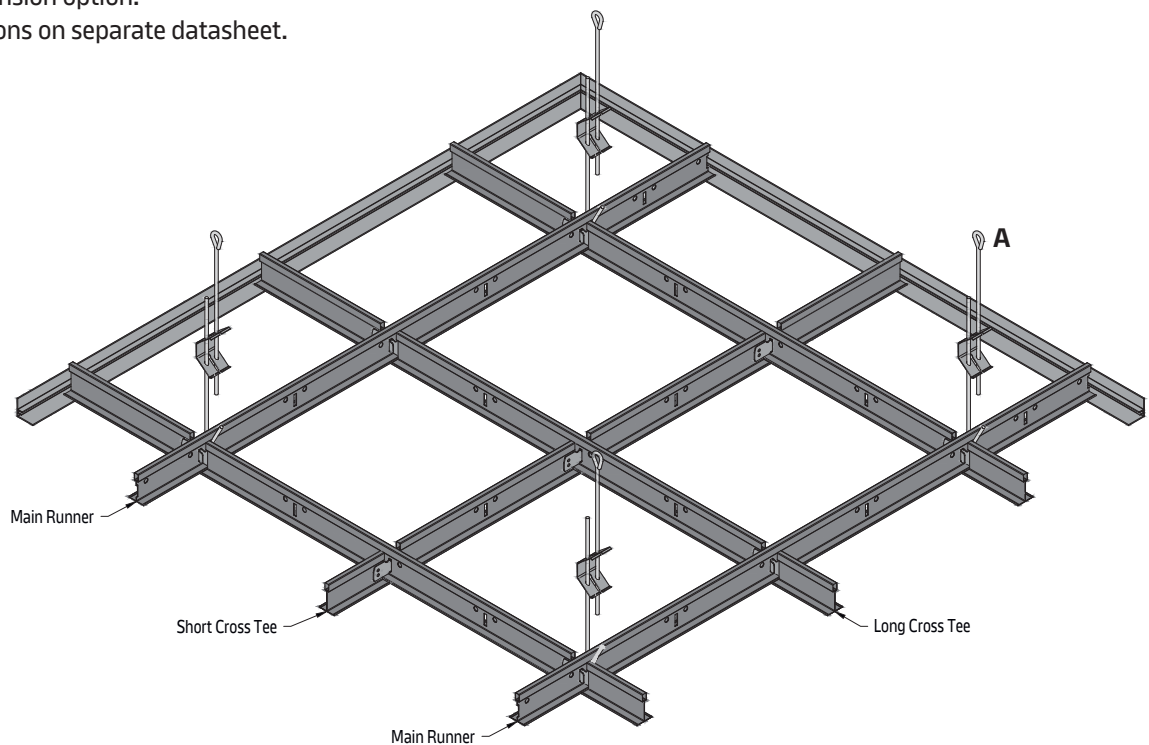

METAL Board / METAL Axal Vector / METAL MicroLook / METAL Tegular

D02.001

Standard layout options

Square tiles

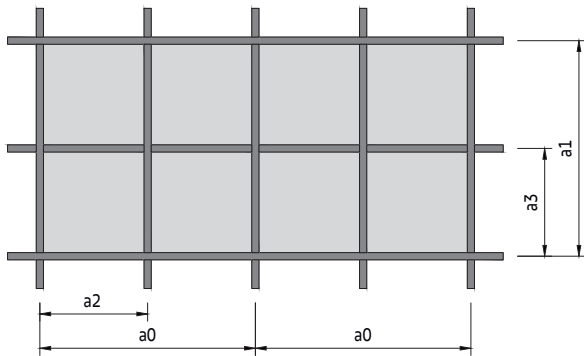

Rectangular tiles, without short Cross Tees

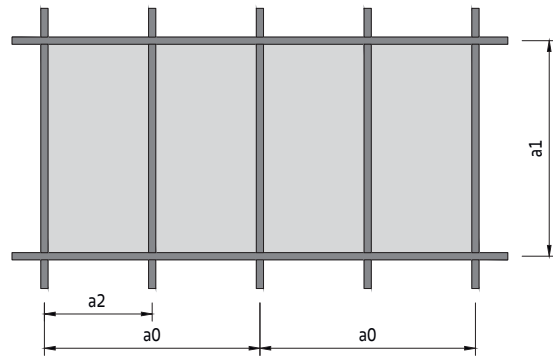

Section B

Example with METAL Board

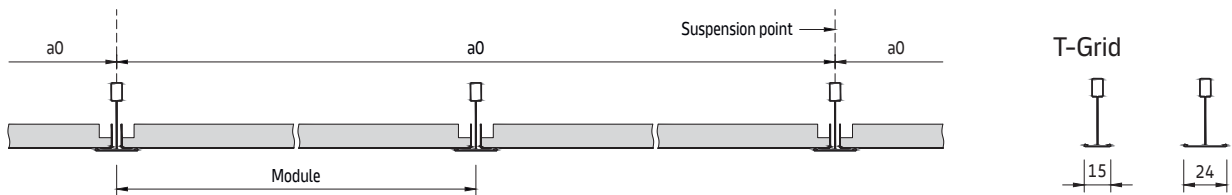

METAL Board

Installed on 24 mm T-Grid, butt-cut (System C)

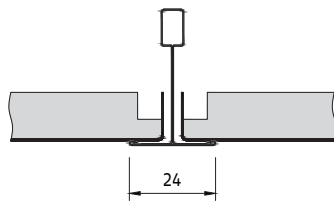

Installed on 15 mm T-Grid, butt-cut (System C)

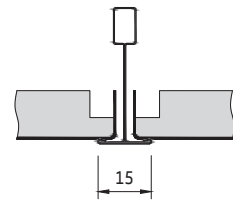

METAL Axal Vector

Tiles with ≈ 7 mm reveal, semi-concealed grid, Installed on 24 mm T-Grid (System C)

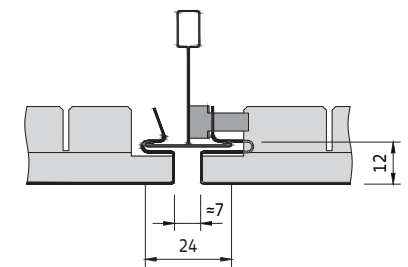

METAL MicroLook 8

Tiles with 8 mm drop
Installed on 15 mm T-Grid (System C)

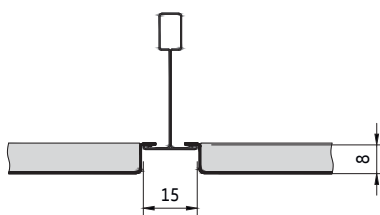

METAL Tegular 2

Tiles with 2.5 mm drop
Installed on 24 mm T-Grid, butt-cut (System C)

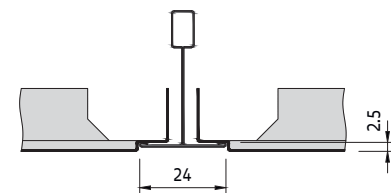

METAL Tegular 8

Tiles with 8 mm drop
Installed on 24 mm T-Grid (System C)

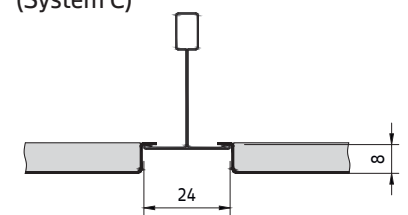

Optional grid components

Components

- M311062 Hold-down clip

See Main Runner for grid components

METAL Board / METAL Axal Vector / METAL MicroLook / METAL Tegular
D02.001

Typical grid layout

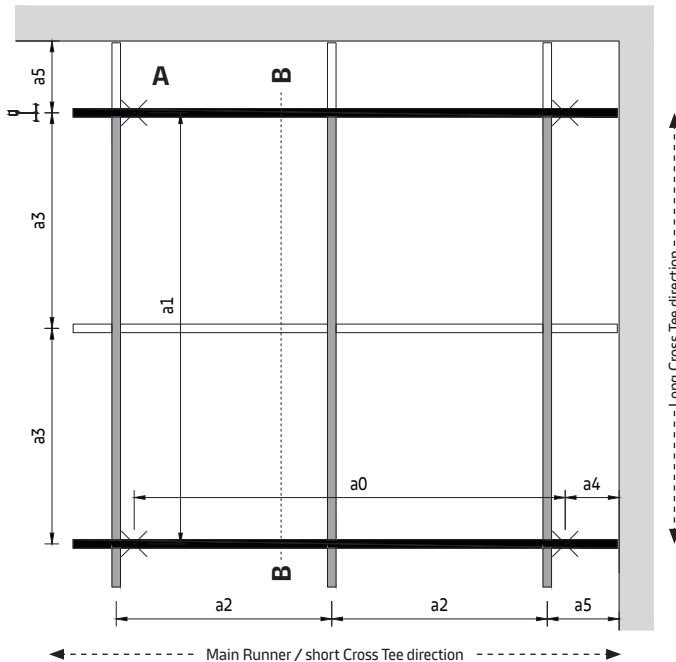

Parameters

- a0 Max. distance between Main Runner suspension points
- a1 Distance between Main Runner
- a2 Distance between Cross Tees (module width)
- a3 Distance between Cross Tees (module length)
- a4 Distance from wall = max. 250 mm
- a5 Distance from wall = max. module length / width, (min. 1/2 module length / width is recommended)

Spacing

a2 [mm]	System without additional load		System with additional load +4 kg/m ²		System with additional load +6 kg/m ²	
	a0 [mm]	a1 [mm]	a0 [mm]	a1 [mm]	a0 [mm]	a1 [mm]
600	1500	1200	1200	1200	950	1200
625	1500	1250	1200	1250	950	1250

Start with the module width / distance between the long Cross Tees (a2) and take the values for (a0) and (a1) next to it. The shown values for (a0) are maximum allowed distances.

Material required per m² (no waste included)

System without additional load

Components	Module [mm]	600 x 600	625 x 625	1200 x 600
Main Runner	[m/m ²]	0.84	0.80	0.84
Long Cross Tee	[m/m ²]	1.67	1.60	1.67
Short Cross Tee	[m/m ²]	0.84	0.80	0
Suspension points (A)	[pcs/m ²]	0.56	0.54	0.56

The shown quantities are theoretical and based on an ideal layout, without considering the actual room layout. The ideal layout is based on a calculation of 10 x 10 m (100 m²). This calculation does not allow any damage, spare nor wastage. The final quantities and type of suspension have to be checked before ordering. Soffit and wall fixings by others.

Not including perimeter trims.

METAL Board / METAL Axal Vector / METAL MicroLook / METAL Tegular
D02.001

Detail C

METAL Board / METAL MicroLook / METAL Tegular

Tile insertion

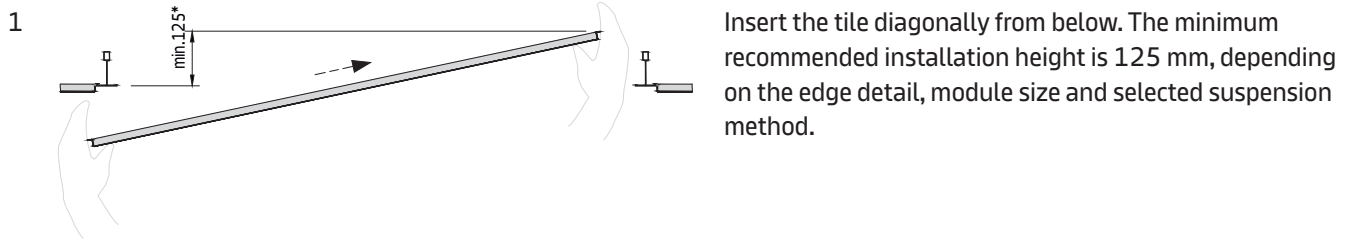

Tile extraction

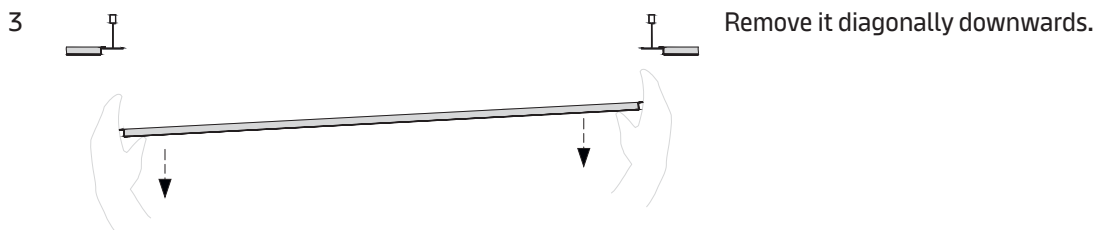
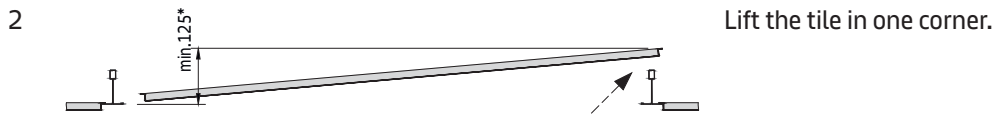

Detail D

The hold down clip option can be used to apply light pressure to the top of the tiles. This is not a security clip solution.

METAL MicroLook 8

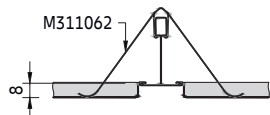

METAL Tegular 8

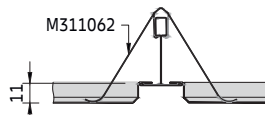

METAL Board / METAL Axal Vector / METAL MicroLook / METAL Tegular
D02.001

Detail E

METAL Axal Vector

Tile insertion

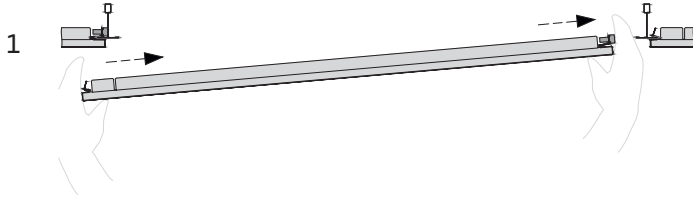

One edge is fitted with two steel spring clips that serve to hold the tile in position. This edge is the first to engage the suspension system.

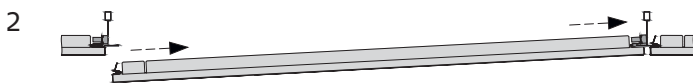

Press the tile with the spring kerf side against the T-Grid flange...



until the kerf on the opposite side can be inserted.



The tiles will automatically centre themselves and must be installed in the same direction.

Tile extraction



All full tiles can be removed and reinstalled downwardly without movement up into the plenum area.



Press the tile with the spring kerf side against the T-Grid flange...



until kerf on the opposite side can be extracted.

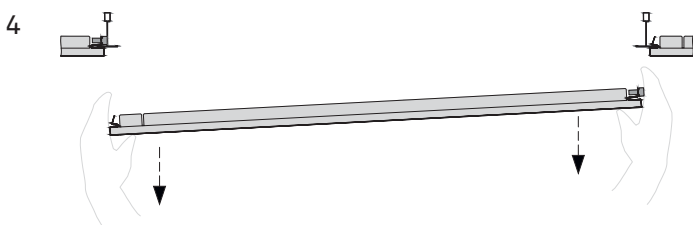

Detail F

METAL Axal Vector locking option

For security applications, METAL Axal Vector can be used where unauthorised removal of tiles is not desirable. This is achieved by installing tiles as normal and folding down the tabs.

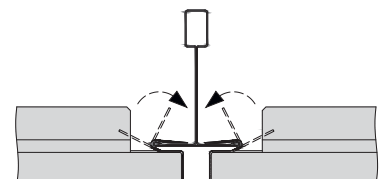
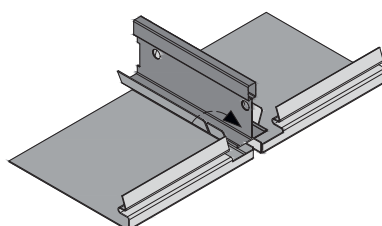



METAL Tegular
Slimming World Headquarters, Alfreton, United Kingdom
© Simon Miles

METAL R-L 201

U-Profile primary grid + L-Profile secondary grid
Exposed grid solution for indoor applications

General information

- Exposed lay-in grid system for medium and large rooms
- For perpendicular installation on U-Profile primary grid
- L-Profile 38 mm in RAL 9010 made of aluminium (colour options on request)
- Typical ceiling weight 7.5 - 9.0 kg/m² (indicative value for unperforated panels, without additional load)
- Panels can be removed individually

Isometric view

Select the suspension option E1 - E4.
Perimeter solutions on separate datasheet.

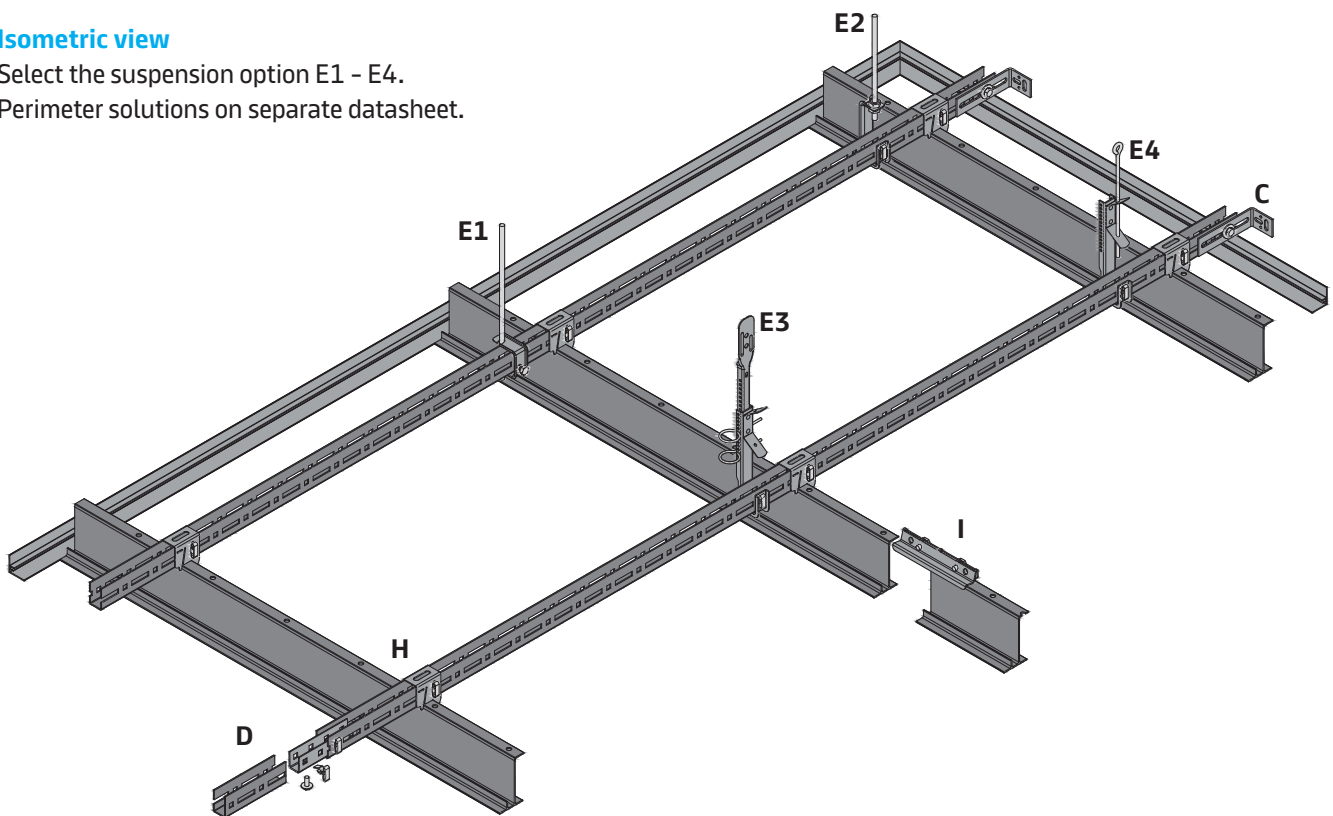

Vario Design & bespoke layout options

Vario Design

Bespoke (on request)

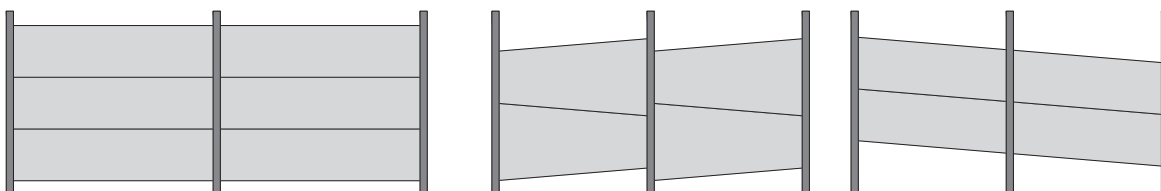

METAL R-L 201
D02.002

Section F

Example with suspension option E1

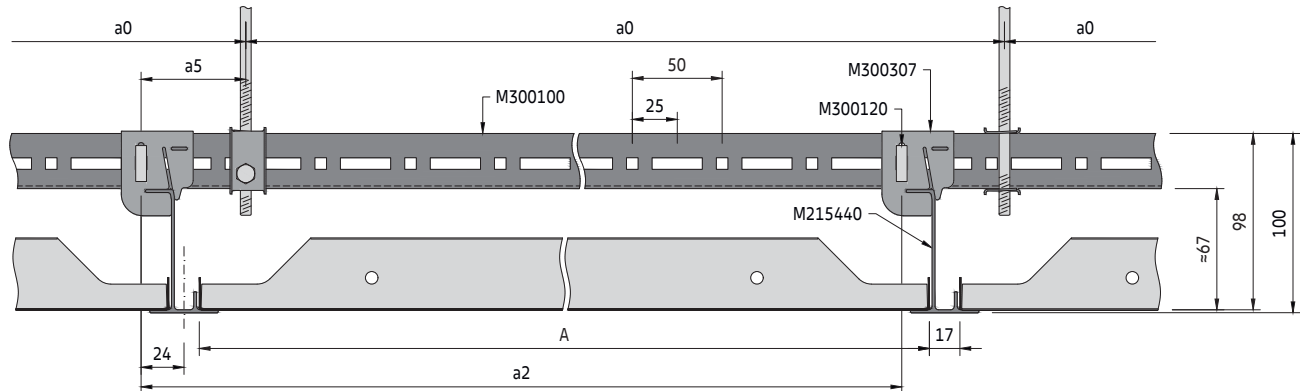

Section G

Example with suspension option E1

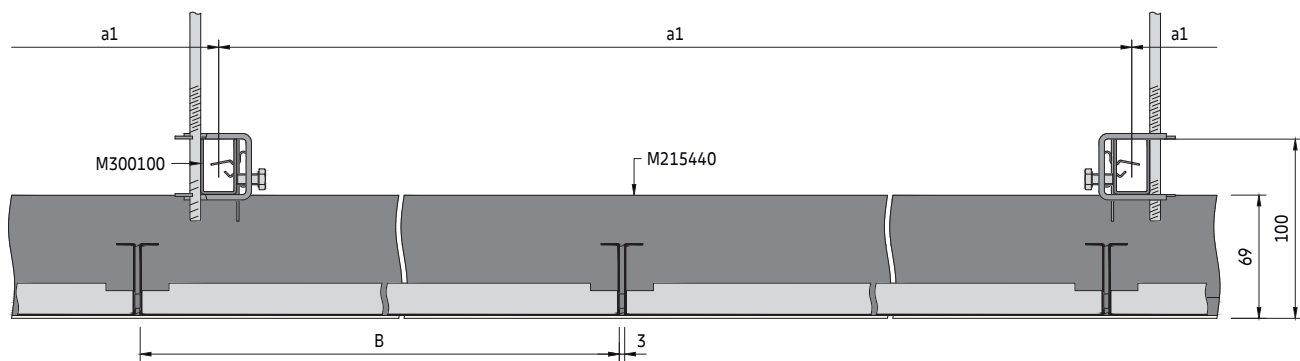

Panels supplied as standard with a 3 mm gasket on one long side to improve the visual appearance. Optionally panels can be installed without a gasket.

Secondary grid components

Standard components

- M215440 L-Profile RAL 9010
- M300343 Splice connector for L-Profile
- M300307 Hanger for L-Profile
- M300120 Plug-in clip for U-Profile

Optional components

- M900000 Black gasket 8x3 mm (spare roll)

See U-Profile primary grid for primary grid components

L-Profile secondary grid

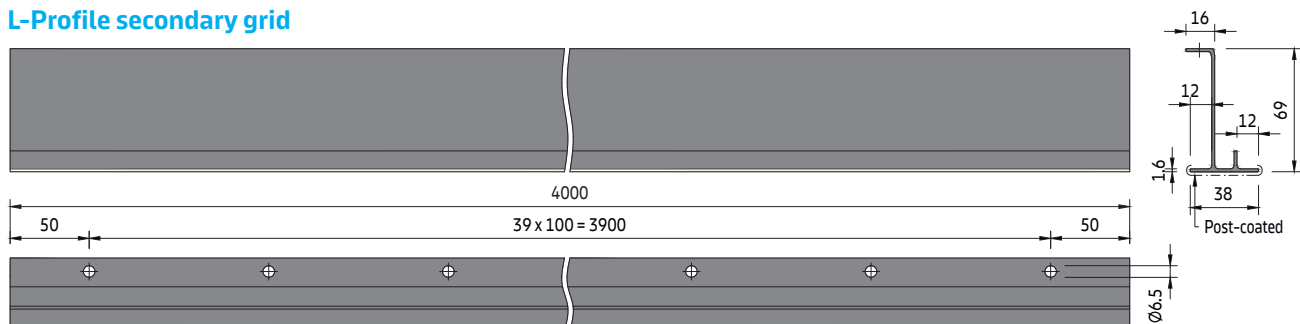

METAL R-L 201
D02.002

Spacing

a2 [mm]	System without additional load		System with additional load +4 kg/m ²		System with additional load +6 kg/m ²	
	a0 [mm]	a1 [mm]	a0 [mm]	a1 [mm]	a0 [mm]	a1 [mm]
600	1200	1900	1200	1900	1200	1600
650	1300	1900	1300	1600	1300	1350
700	1400	1900	1400	1400	1400	1150
750	1500	1900	750	1200	1500	1000
800	1600	1650	800	1050	1600	850
850	1700	1400	850	900	1700	750
900	900	1900	900	1900	900	1900
950	950	1900	950	1900	950	1900
1000	1000	1900	1000	1900	1000	1850
1050	1050	1900	1050	1850	1050	1800
1100	1100	1900	1100	1850	1100	1750
1150	1150	1900	1150	1800	1150	1700
1200	1200	1900	1200	1750	1200	1600
1250	1250	1900	1250	1700	1250	1500
1300	1300	1900	1300	1600	1300	1350
1350	1350	1850	1350	1450	1350	1250
1400	1400	1800	1400	1350	1400	1150
1450	1450	1800	1450	1250	1450	1050
1500	1500	1750	1500	1150	1500	1000
1550	1550	1700	1550	1100	1550	900
1600	1600	1600	1600	1000	1600	850
1650	1650	1500	1650	950	1650	800
1700	1700	1400	1700	900	1700	750
1750	1750	1300	1750	800	1750	700
1800	1800	1150	1800	750	1800	650
1850	1850	1050	1850	700	1850	550
1900	1900	950	1900	600	1900	500
1950	975	1550	975	1350	975	1300
2000	1000	1500	1000	1350	1000	1300
2050	1025	1500	1025	1350	1025	1300
2100	1050	1500	1050	1300	1050	1250
2150	1075	1450	1075	1300	1075	1250
2200	1100	1450	1100	1300	1100	1250
2250	1125	1450	1125	1250	1125	1200
2300	1150	1400	1150	1250	1150	1200
2350	1175	1400	1175	1250	1175	1200
2400	1200	1400	1200	1250	1200	1200
2450	1225	1350	1225	1200	-	-
2500	1250	1350	1250	1200	-	-
2600	1300	1300	1300	1200	-	-
2700	1350	1300	1350	1150	-	-
2800	1400	1250	1400	1100	-	-
2900	1450	1250	1450	1100	-	-
3000	1500	1200	1500	1100	-	-
3100	1550	1200	1550	1050	-	-
3200	1600	1150	1600	950	-	-
3300	1650	1150	1650	900	-	-

Parameters

- a0 Distance between U-Profile suspension points = max. 1900 mm
- a1 Max. distance between U-Profiles
- a2 Distance between L-Profiles = panel length + 17 mm
- a3 Distance from wall = max. 200 mm
- a4 Distance from wall = max. panel length
- a5 Distance from U-Profile suspension point to hanger = max. 100 mm
- M Module size = panel length + 17 mm / panel width + gasket
- A Panel length = min. 600 / max. 3300 mm
- B Panel width = min. 247 / max. 1350 mm

Typical grid layout

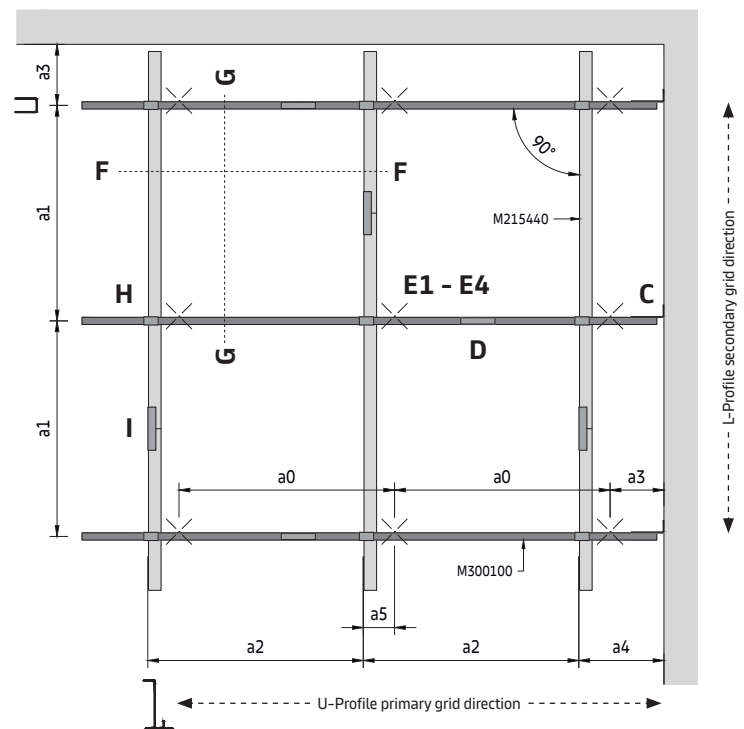

To determine suspension layout

The module length (M) of the requested ceiling is equal to the distance between the L-Profile centres (a2).

On the appropriate spacing table, read down the column headed (a2) to the required module length then read across to determine the suspension point spacing (a0) and U-Profile spacing (a1).

The shown values are maximum allowed distances and can be reduced but not exceeded.

Detail H

Hanger installation

- 1

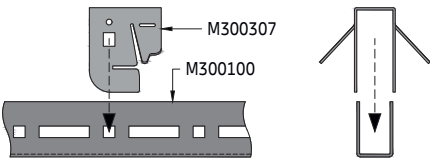

Place the hanger on the U-profile.

- 2

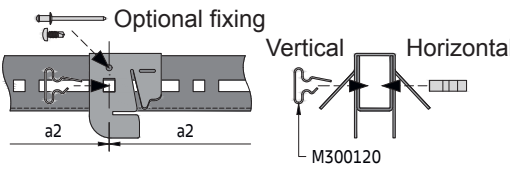

Fix hanger with plug-in clips at the specified module spacing (inserted vertically or horizontally). If the panel size does not fit with the modulation of the U-Profile (25 mm increments), the plug-in clip needs to be inserted into a long hole. The hanger position can alternatively be fixed by using a pop-riquet or self-drilling screw.

- 3

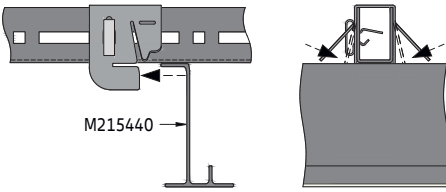

Insert the L-Profile into the hanger, press down the two hanger wings to lock the position of the L-Profile.

- 4

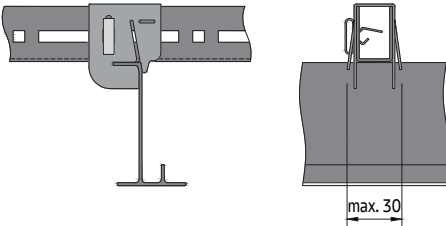

The L-Profile is now locked in position.

Detail I

Splice connection

- 1

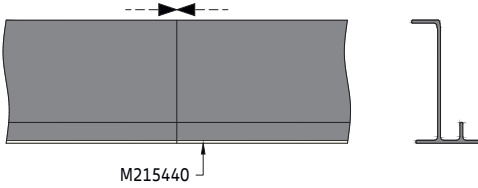

Once the L-Profiles are installed under the U-Profiles, the ends should be brought together without a gap.

- 2

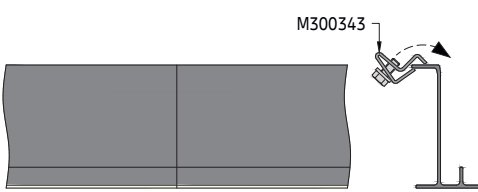

The connectors for the L-Profiles must be inserted from above.

- 3

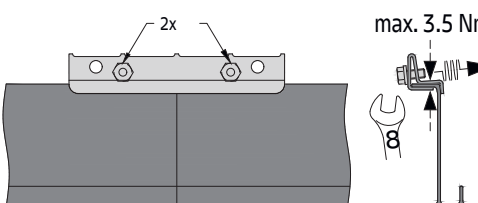

Use the bolts to secure the connector. Stagger the joints.

Detail J

Panel insertion

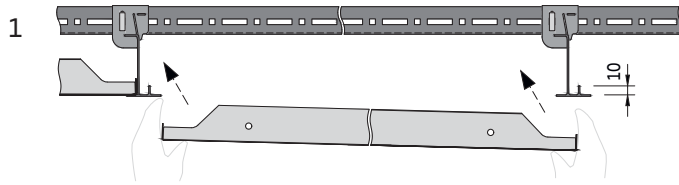

The L-Profile was designed asymmetrically with an additional upstand of 10 mm. As a result, the panels are a little shorter and require less height when installing and extracting.

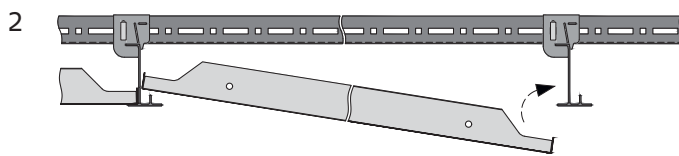

Insert the panel first on the side where the upstand of the L-Profile is, followed by the opposite side.

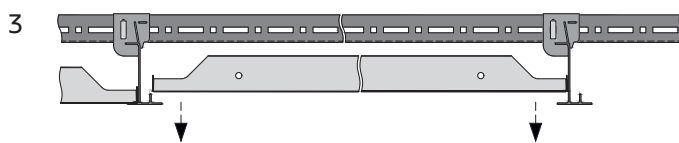

The panel is placed horizontally on the L-Profiles.

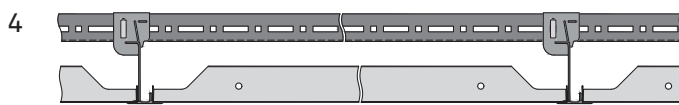

Continue with the next panel.

Panel extraction

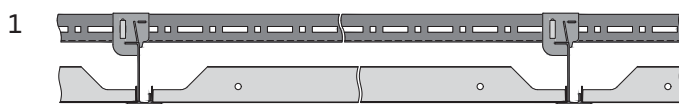

With a closed ceiling, any panel can be removed as long as there are no obstacles such as service integrations, etc.

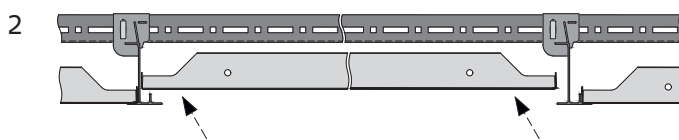

Lift the panel and move it to the direction where the L-Profile upstand is.

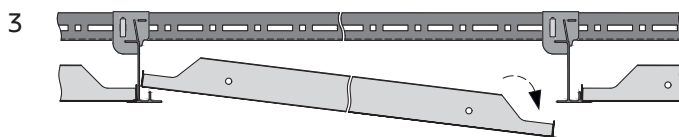

Lower the opposite side.

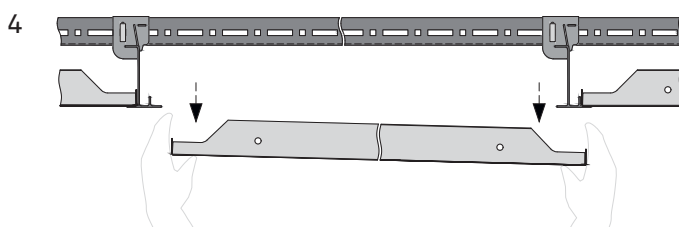

Remove it downwards and store the panel in a safe place so that it cannot be damaged.

METAL R-L 201

D02.002

Material required per m² (no waste included)

System without additional load [pcs/m²]

Components		a2 [mm]	1200	1600	1800	2000	2400	2800	3100	3300
M215440	L-Profile RAL 9010		0.21	0.16	0.14	0.13	0.10	0.09	0.08	0.08
M300100	U-Profile		0.14	0.17	0.23	0.18	0.19	0.21	0.22	0.23
M300119	Splice connector for U-Profile		0.15	0.17	0.24	0.18	0.20	0.22	0.23	0.24
M300120	Plug-in clip for U-Profile		0.74	0.74	0.97	0.70	0.70	0.73	0.73	0.75
M300140	Wall anchor		0.06	0.07	0.09	0.07	0.08	0.09	0.09	0.09
M300307	Hanger for L-Profile		0.44	0.40	0.49	0.34	0.30	0.29	0.27	0.27
M300343	Splice connector for L-Profile		0.21	0.16	0.14	0.13	0.11	0.09	0.09	0.08
M311103	Hexagonal nut M6		0.10	0.10	0.10	0.10	0.10	0.10	0.10	0.10
M311105	Washer		0.10	0.10	0.10	0.10	0.10	0.10	0.10	0.10
M311303	Hexagonal bolt M6 x 16 mm		0.10	0.10	0.10	0.10	0.10	0.10	0.10	0.10
Various	Suspension points (E1 - E4)		0.44	0.40	0.49	0.67	0.60	0.58	0.54	0.53

The shown quantities are theoretical and based on an ideal layout, without considering the actual room layout. The ideal layout is based on a calculation of 10 x 10 m (100 m²). This calculation does not allow any damage, spare nor wastage. The final quantities and type of suspension have to be checked before ordering. Soffit and wall fixings by others.

Not including perimeter trims, optional security brackets and extraction tools.

METAL R-L 201

Primary angle primary grid + L-Profile secondary grid
Exposed grid solution for indoor applications

General information

- Exposed lay-in grid system for medium and large rooms
- For perpendicular or radial installation on primary angle primary grid (27 x 22 / 50 x 22 mm option)
- L-Profile 38 mm in RAL 9010 made of aluminium (colour options on request)
- Typical ceiling weight 7.5 - 9.0 kg/m² (indicative value for unperforated panels, without additional load)
- Panels are easily installed and fully demountable

Isometric view

Example with primary angle 27 x 22 mm
Perimeter solutions on separate datasheet.

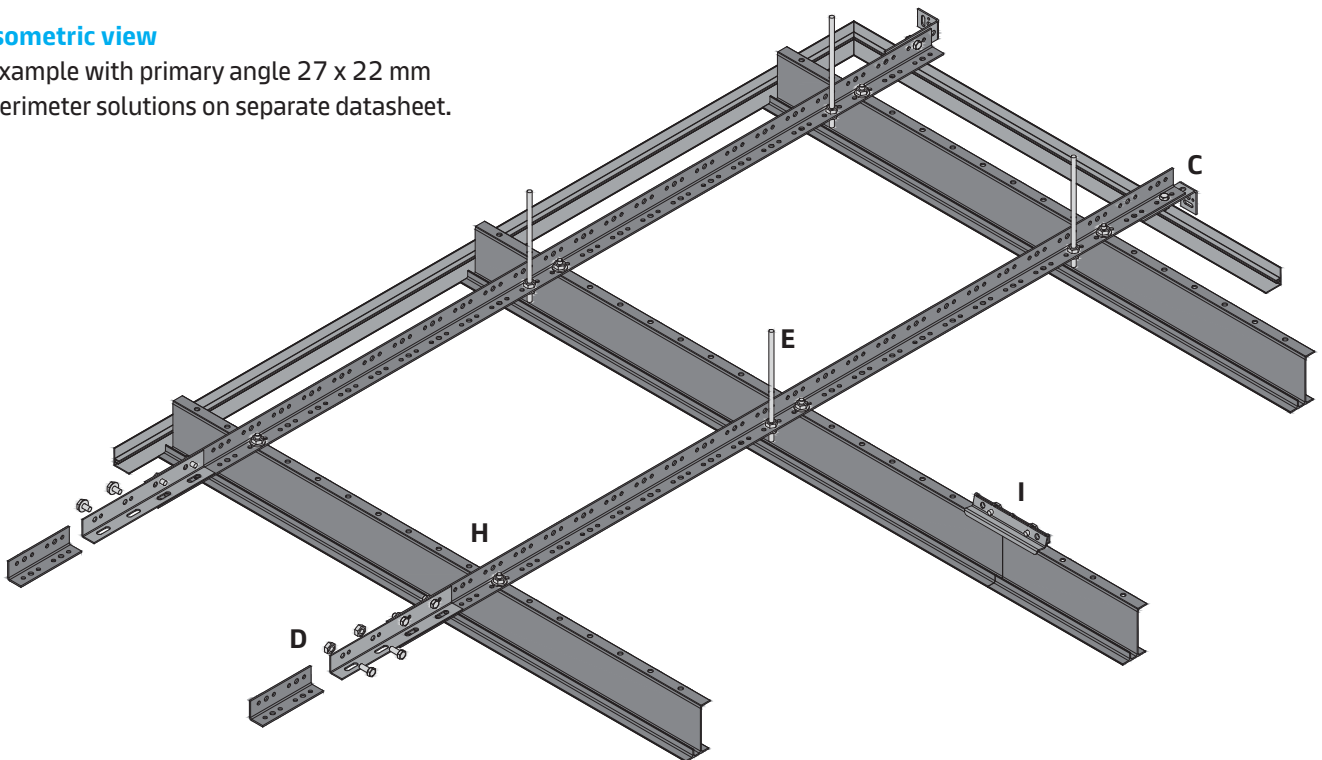

Vario Design & bespoke layout options

Vario Design

Bespoke (on request)

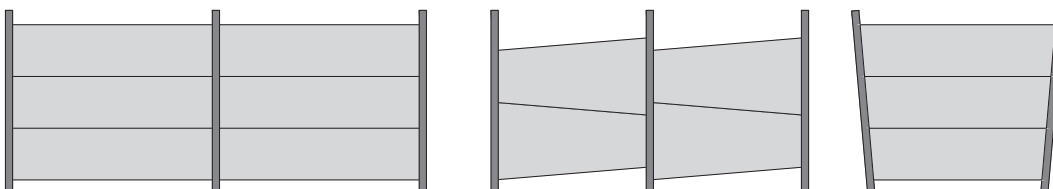

METAL R-L 201

D02.002.1

Section F

Example with primary angle 27 x 22 mm

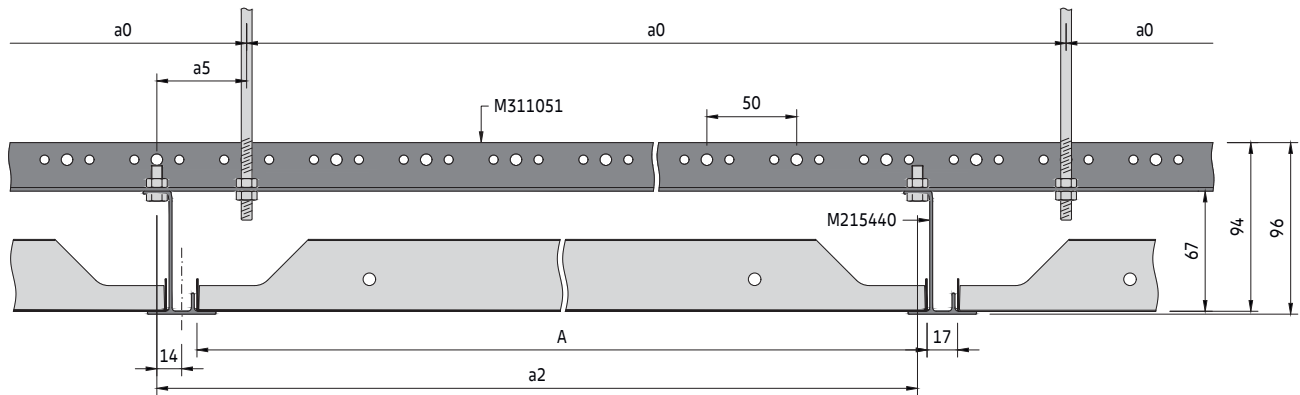

Section G

Example with primary angle 27 x 22 mm

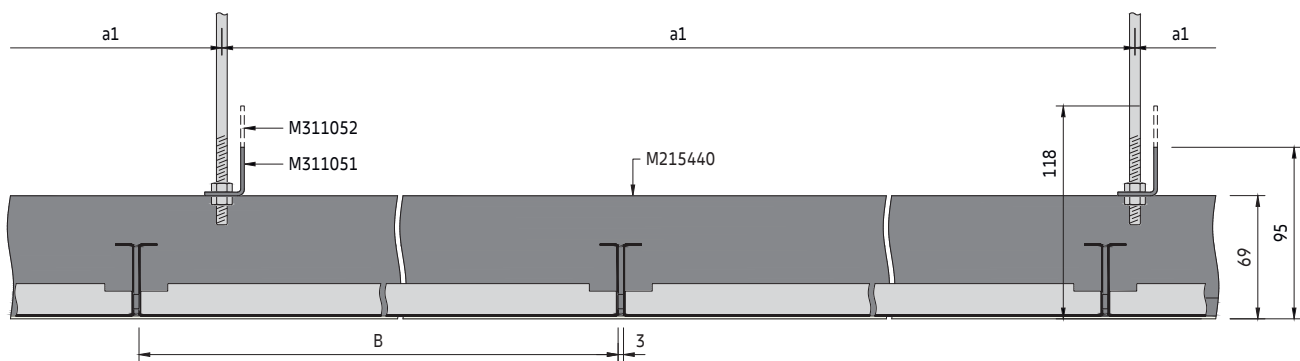

Panels supplied as standard with a 3 mm gasket on one long side to improve the visual appearance. Optionally panels can be installed without a gasket.

Secondary grid components

Standard components

- M215440 L-Profile RAL 9010
- M300343 Splice connector for L-Profile

Optional components

- M900000 Black gasket 8x3 mm (spare roll)

See primary angle primary grid for primary grid components

L-Profile secondary grid

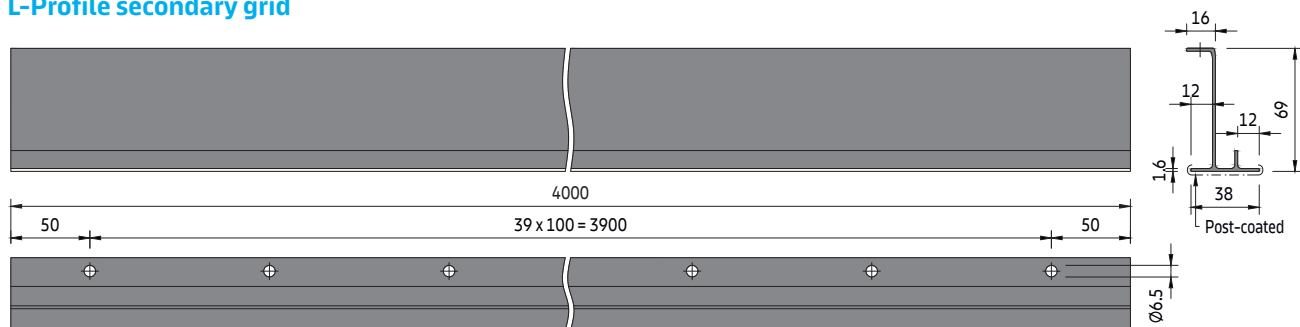

METAL R-L 201
D02.002.1

Spacing for primary angle 27 x 22 mm

a2 [mm]	System without additional load		System with additional load +4 kg/m ²		System with additional load +6 kg/m ²	
	a0 [mm]	a1 [mm]	a0 [mm]	a1 [mm]	a0 [mm]	a1 [mm]
600	1200	1500	1200	1500	1200	1500
650	1300	1500	1300	1500	1300	1200
700	1400	1500	1400	1200	1400	1000
750	1500	1500	750	1000	750	750
800	1600	1500	800	750	800	750
850	1700	1200	850	750	850	750
900	900	1500	900	1500	900	1500
950	950	1500	950	1500	950	1500
1000	1000	1500	1000	1500	1000	1500
1050	1050	1500	1050	1500	1050	1500
1100	1100	1500	1100	1500	1100	1500
1150	1150	1500	1150	1500	1150	1500
1200	1200	1500	1200	1500	1200	1200
1250	1250	1500	1250	1200	1250	1200
1300	1300	1500	1300	1200	1300	1200
1350	1350	1500	1350	1200	1350	1000
1400	1400	1500	1400	1000	1400	750
1450	1450	1500	1450	1000	1450	750
1500	1500	1500	1500	1000	1500	750
1550	1550	1500	1550	750	1550	600
1600	1600	1200	1600	750	1600	600
1650	1650	1200	1650	750	1650	600
1700	1700	1200	1700	750	1700	600
1750	1750	1200	1750	750	1750	600
1800	1800	1000	1800	600	1800	500
1850	1850	750	1850	600	1850	500
1900	1900	750	1900	500	1900	500
1950	975	1200	975	1000	975	750
2000	1000	1200	1000	1000	1000	750
2050	1025	1200	1025	1000	1025	750
2100	1050	1200	1050	1000	1050	750
2150	1075	1200	1075	1000	1075	750
2200	1100	1200	1100	1000	1100	750
2250	1125	1200	1125	1000	1125	750
2300	1150	1200	1150	1000	1150	750
2350	1175	1200	1175	1000	1175	750
2400	1200	1200	1200	1000	1200	750
2450	1225	1000	1225	1000	-	-
2500	1250	1000	1250	1000	-	-
2600	1300	1000	1300	1000	-	-
2700	1350	1000	1350	750	-	-
2800	1400	1000	1400	750	-	-
2900	1450	1000	1450	750	-	-
3000	1500	1000	1500	750	-	-
3100	1550	1000	1550	750	-	-
3200	1600	750	1600	750	-	-
3300	1650	750	1650	750	-	-

Spacing for primary angle 50 x 22

a2 [mm]	System without additional load		System with additional load +4 kg/m ²		System with additional load +6 kg/m ²	
	a0 [mm]	a1 [mm]	a0 [mm]	a1 [mm]	a0 [mm]	a1 [mm]
600	1200	1900	1200	1900	1200	1900
650	1300	1900	1300	1900	1300	1900
700	1400	1900	1400	1900	1400	1900
750	1500	1900	750	1900	750	1900
800	1600	1900	800	1900	800	1900
850	1700	1900	850	1900	850	1900
900	900	1900	900	1900	900	1900
950	950	1900	950	1900	950	1900
1000	1000	1900	1000	1900	1000	1900
1050	1050	1900	1050	1900	1050	1900
1100	1100	1900	1100	1900	1100	1900
1150	1150	1900	1150	1900	1150	1900
1200	1200	1900	1200	1900	1200	1900
1250	1250	1900	1250	1900	1250	1900
1300	1300	1900	1300	1900	1300	1900
1350	1350	1900	1350	1900	1350	1900
1400	1400	1900	1400	1900	1400	1900
1450	1450	1900	1450	1900	1450	1900
1500	1500	1900	1500	1900	1500	1900
1550	1550	1900	1550	1900	1550	1750
1600	1600	1900	1600	1900	1600	1650
1650	1650	1900	1650	1900	1650	1550
1700	1700	1900	1700	1900	1700	1450
1750	1750	1850	1750	1850	1750	1350
1800	1800	1700	1800	1700	1800	1250
1850	1850	1550	1850	1550	1850	1100
1900	1900	1450	1900	1450	1900	1050
1950	975	1900	975	1900	975	1750
2000	1000	1900	1000	1900	1000	1750
2050	1025	1900	1025	1900	1025	1700
2100	1050	1900	1050	1900	1050	1700
2150	1075	1900	1075	1900	1075	1700
2200	1100	1900	1100	1900	1100	1700
2250	1125	1900	1125	1850	1125	1650
2300	1150	1900	1150	1850	1150	1650
2350	1175	1900	1175	1850	1175	1650
2400	1200	1900	1200	1850	1200	1650
2450	1225	1900	1225	1800	-	-
2500	1250	1900	1250	1800	-	-
2600	1300	1900	1300	1800	-	-
2700	1350	1900	1350	1750	-	-
2800	1400	1900	1400	1750	-	-
2900	1450	1900	1450	1700	-	-
3000	1500	1900	1500	1700	-	-
3100	1550	1900	1550	1700	-	-
3200	1600	1900	1600	1650	-	-
3300	1650	1900	1650	1650	-	-

METAL R-L 201

D02.002.1

Parameters

- a0 Distance between primary angle suspension points = max. 1900 mm
- a1 Max. distance between primary angles
- a2 Distance between L-Profiles = panel length + 17 mm
- a3 Distance from wall = max. 200 mm
- a4 Distance from wall = max. panel length
- a5 Distance from primary angle suspension point to hanger = max. 100 mm
- M Module size = panel length + 17 mm / panel width + gasket
- A Panel length = min. 600 / max. 3300 mm
- B Panel width = min. 247 / max. 1350 mm

Typical grid layout

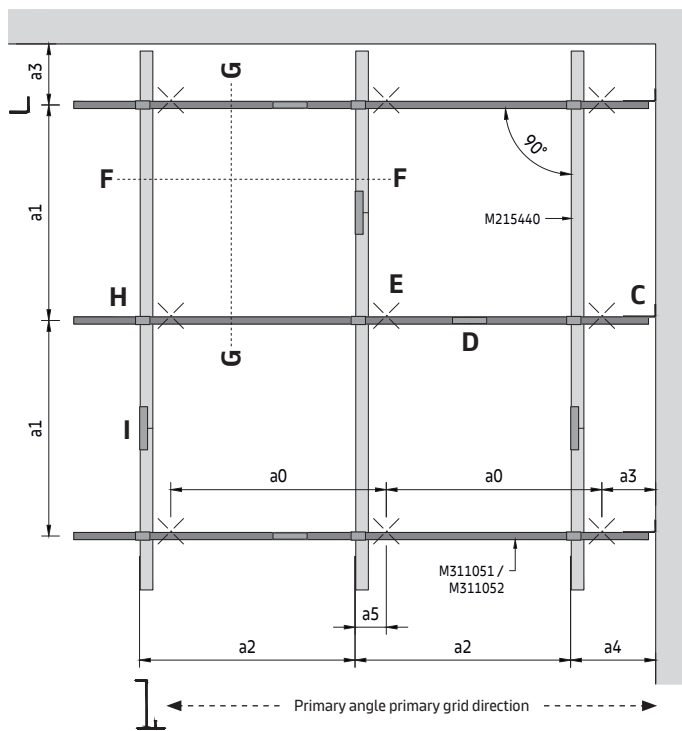

To determine suspension layout

The module length (M) of the requested ceiling is equal to the distance between the DP12 A-Bar centres (a2).

On the appropriate spacing table, read down the column headed (a2) to the required module length then read across to determine the suspension point spacing (a0) and direct hanger spacing (a1).

The shown values are maximum allowed distances and can be reduced but not exceeded.

Detail H

L-Profile fixing

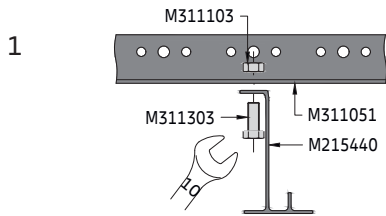

Use an M6 bolt and nut to screw the L-Profile below the primary angle.

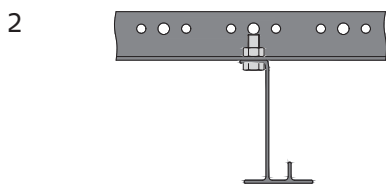

The L-Profile is now fixed.

Detail I

Splice connection

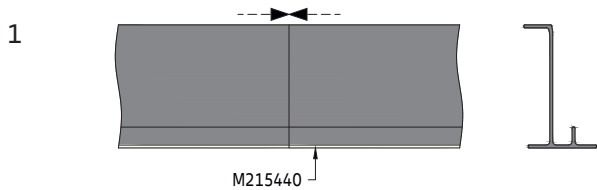

Once the L-Profiles are installed under the U-Profiles, the ends should be brought together without a gap.

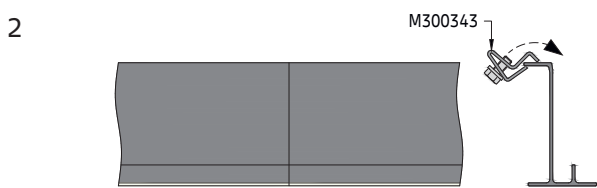

The connectors for the L-Profiles must be inserted from above.

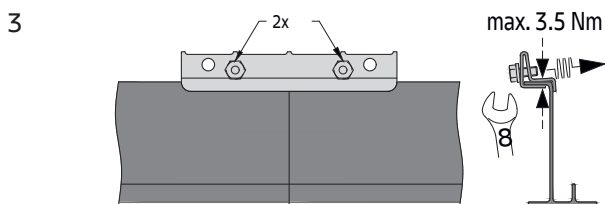

Use the bolts to secure the connector. Stagger the joints.

METAL R-L 201

D02.002.1

Material required per m² (no waste included)**System without additional load [pcs/m²]**

Components		a2 [mm]	1200	1600	1800	2000	2400	2800	3100	3300
M215440	L-Profile RAL 9010		0.21	0.16	0.14	0.13	0.10	0.09	0.08	0.08
M311051	Primary angle 27 x 22 mm		0.22	0.28	0.33	0.28	0.28	0.33	0.33	0.44
M311053	Splice connector for primary angle *		0.23	0.28	0.34	0.28	0.28	0.34	0.34	0.45
M300140	Wall anchor		0.06	0.07	0.09	0.07	0.08	0.09	0.09	0.09
M300343	Splice connector for L-Profile		0.21	0.16	0.14	0.13	0.11	0.09	0.09	0.08
M311099	Threaded rod M6 x 1000 mm		0.56	0.53	0.56	0.84	0.7	0.72	0.65	0.81
M311103	Hexagonal nut M6		0.16	0.17	0.20	0.21	0.19	0.22	0.21	0.28
M311105	Washer		0.10	0.10	0.10	0.10	0.10	0.10	0.10	0.10
M311303	Hexagonal bolt M6 x 16 mm		0.16	0.17	0.20	0.21	0.19	0.22	0.21	0.28

*Option with M6 bolt and nut

The shown quantities are theoretical and based on an ideal layout, without considering the actual room layout. The ideal layout is based on a calculation of 10 x 10 m (100 m²). This calculation does not allow any damage, spare nor wastage. The final quantities and type of suspension have to be checked before ordering. Soffit and wall fixings by others.

Not including perimeter trims, optional security brackets and extraction tools.

Detail J

Panel insertion

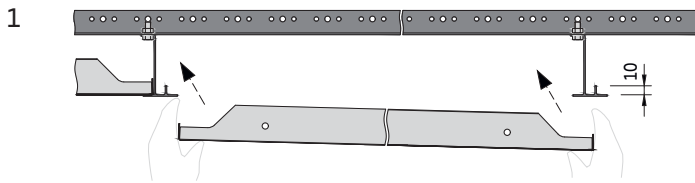

The L-Profile was designed asymmetrically with an additional upstand of 10 mm. As a result, the panels are a little shorter and require less height when installing and extracting.

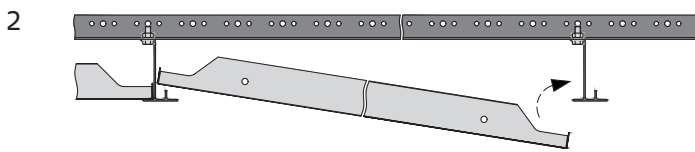

Insert the panel first on the side where the upstand of the L-Profile is, followed by the opposite side.

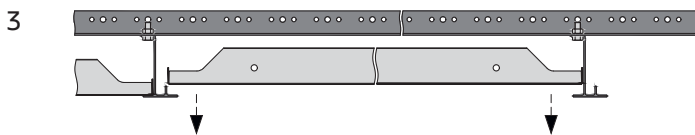

The panel is placed horizontally on the L-Profiles.

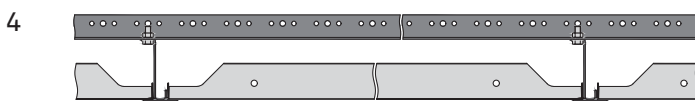

Continue with the next panel.

Panel extraction

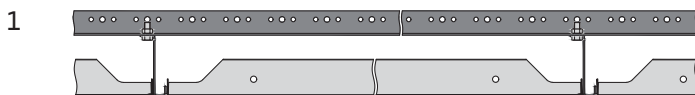

With a closed ceiling, any panel can be removed as long as there are no obstacles such as service integrations, etc.

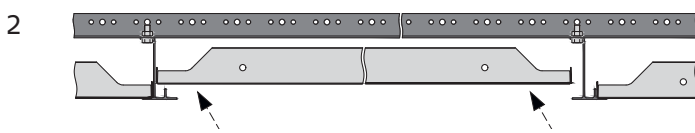

Lift the panel and move it to the direction where the L-Profile upstand is.

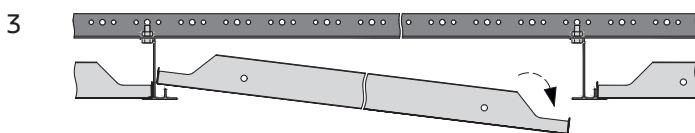

Lower the opposite side.

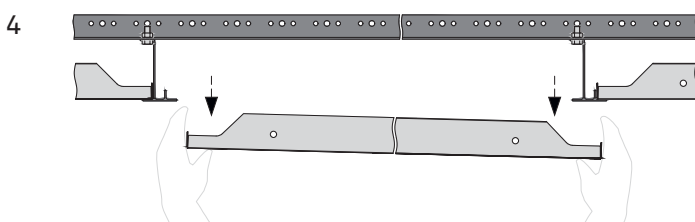

Remove it downwards and store the panel in a safe place so that it cannot be damaged.



METAL B-H 300
Office Building K2, Gdynia, Poland
© Szymon Polański

METAL R-L 201

Direct suspended L-Profile
Exposed grid solution for indoor applications

General information

- Exposed lay-in grid system for small rooms with low cavity
- For perpendicular or radial installation
- L-Profile 38 mm in RAL 9010 made of aluminium (colour options on request)
- Typical ceiling weight 7.0 - 8.5 kg/m² (indicative value for unperforated panels, without additional load)
- Panels are easily installed and fully demountable

Isometric view

Perimeter solutions on separate datasheet.

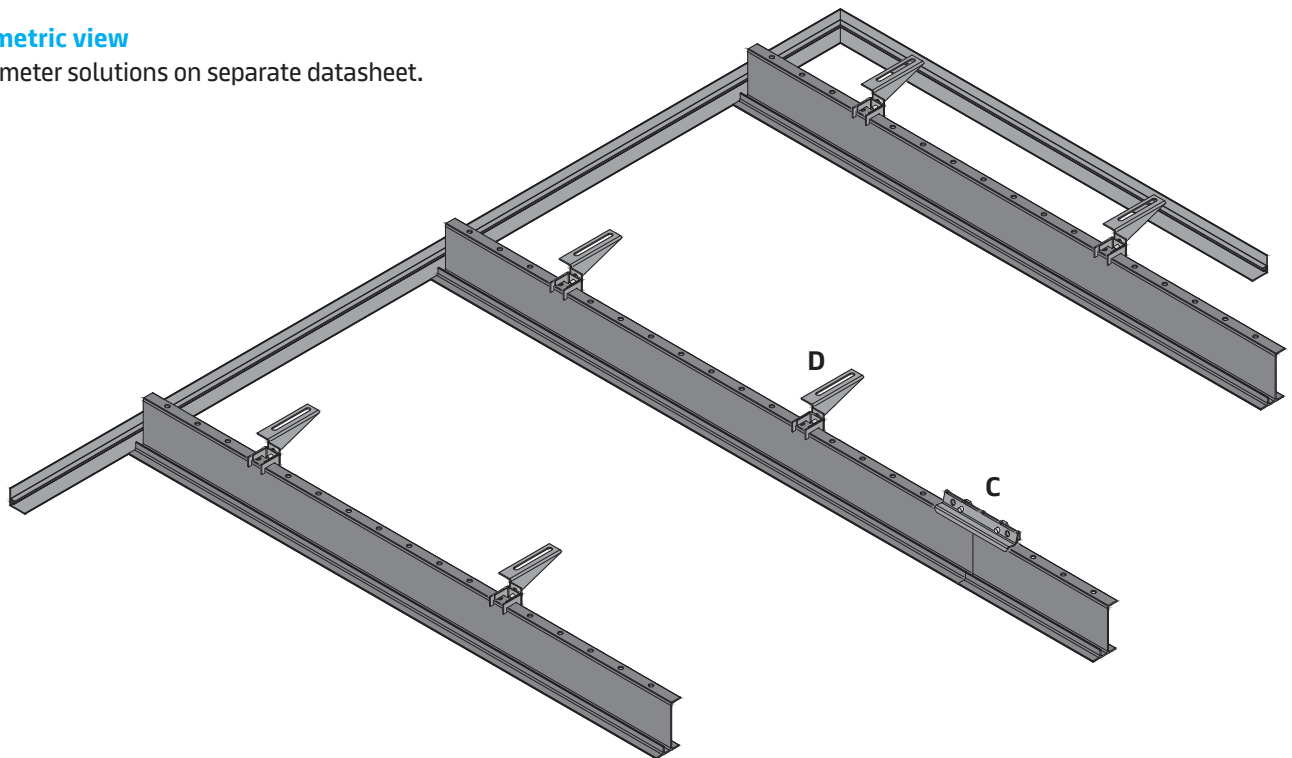

The use of a primary grid system is recommended, as this simplifies levelling and the alignment of the ceiling.

Vario Design & bespoke layout options

Vario Design

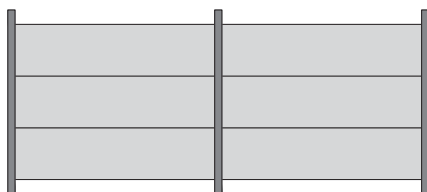

Bespoke (on request)

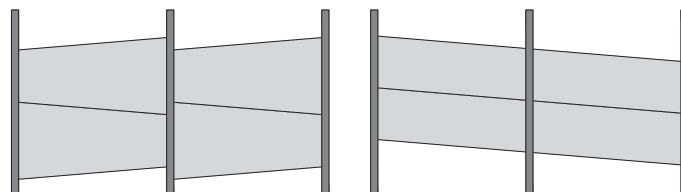

Section A

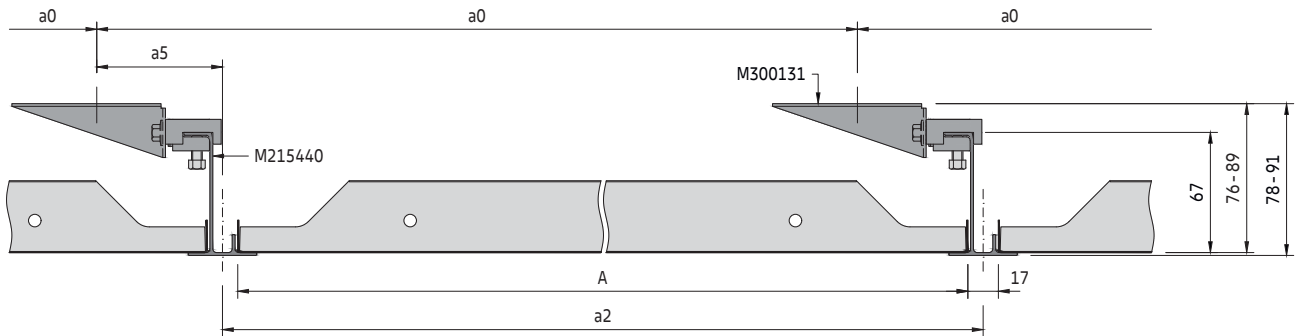

Section B

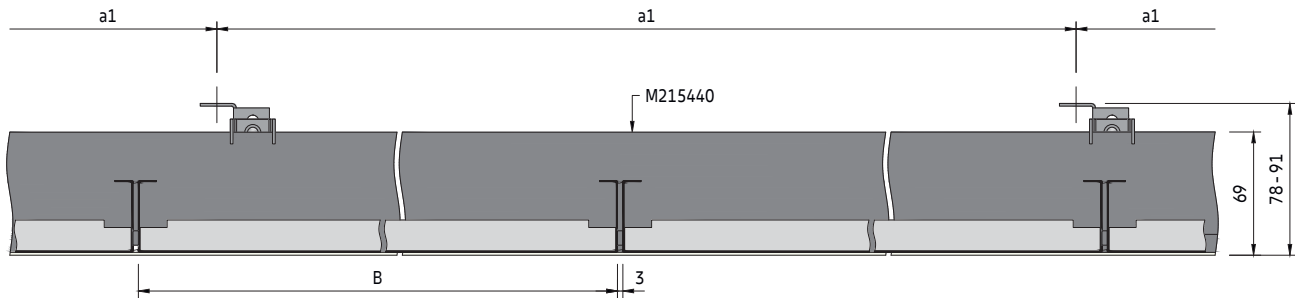

Panels supplied as standard with a 3 mm gasket on one long side to improve the visual appearance. Optionally panels can be installed without a gasket.

Secondary grid components

Standard components

- M215440 L-Profile RAL 9010
- M300343 Splice connector for L-Profile
- M300131 Direct hanger for L-Profile

Optional components

- M900000 Black gasket 8x3 mm (spare roll)

L-Profile

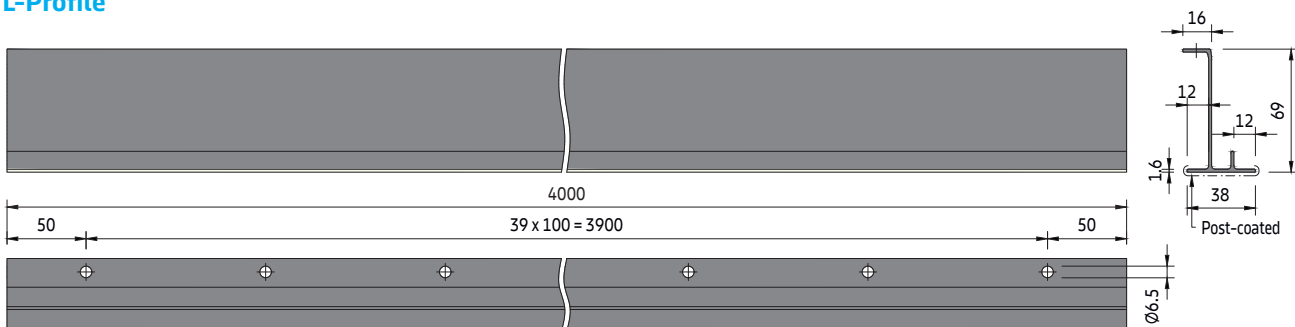

Spacing

a2 [mm]	System without additional load		System with additional load +4 kg/m ²		System with additional load +6 kg/m ²	
	a0 [mm]	a1 [mm]	a0 [mm]	a1 [mm]	a0 [mm]	a1 [mm]
600	600	1500	600	1500	600	1500
650	650	1500	650	1500	650	1500
700	700	1500	700	1500	700	1500
750	750	1500	750	1500	750	1500
800	800	1500	800	1500	800	1500
850	850	1500	850	1500	850	1500
900	900	1500	900	1500	900	1500
950	950	1500	950	1500	950	1500
1000	1000	1500	1000	1500	1000	1500
1050	1050	1500	1050	1500	1050	1500
1100	1100	1500	1100	1500	1100	1500
1150	1150	1500	1150	1500	1150	1500
1200	1200	1500	1200	1500	1200	1500
1250	1250	1500	1250	1500	1250	1200
1300	1300	1500	1300	1500	1300	1200
1350	1350	1500	1350	1200	1350	1200
1400	1400	1500	1400	1200	1400	1000
1450	1450	1500	1450	1200	1450	1000
1500	1500	1500	1500	1000	1500	1000
1550	1550	1500	1550	1000	1550	800
1600	1600	1500	1600	1000	1600	800
1650	1650	1500	1650	800	1650	800
1700	1700	1200	1700	800	1700	700
1750	1750	1200	1750	800	1750	700
1800	1800	1000	1800	600	1800	600
1850	1850	1000	1850	600	1850	600
1900	1900	800	1900	600	1900	500
1950	1950	800	1950	600	1950	500
2000	2000	800	2000	600	2000	500
2050	2050	800	2050	600	2050	500
2100	2100	800	2100	600	2100	500
2150	2150	800	2150	600	2150	500
2200	2200	800	2200	600	2200	500
2250	2250	800	2250	400	2250	400
2300	2300	800	2300	400	2300	400
2350	2350	600	2350	400	2350	300
2400	2400	600	2400	400	2400	300
2450	2450	600	2450	400	-	-
2500	2500	600	2500	400	-	-
2600	2600	600	2600	400	-	-
2700	2700	600	2700	400	-	-
2800	2800	600	2800	400	-	-
2900	2900	600	2900	400	-	-
3000	3000	600	3000	400	-	-
3100	3100	600	3100	400	-	-
3200	3200	600	3200	400	-	-
3300	3300	600	3300	400	-	-

Parameters

- a0 Distance between L-Profile suspension points = max. 1900 mm
- a1 Max. distance between direct hangers
- a2 Distance between L-Profiles = panel length + 17 mm
- a3 Distance from wall = max. 200 mm
- a4 Distance from wall = max. panel length
- a5 Distance between L-Profile and top fixing = max. 70 mm
- M Module size = panel length + 17 mm / panel width + gasket
- A Panel length = min. 600 / max. 3300 mm
- B Panel width = min. 247 / max. 1350 mm

Typical grid layout

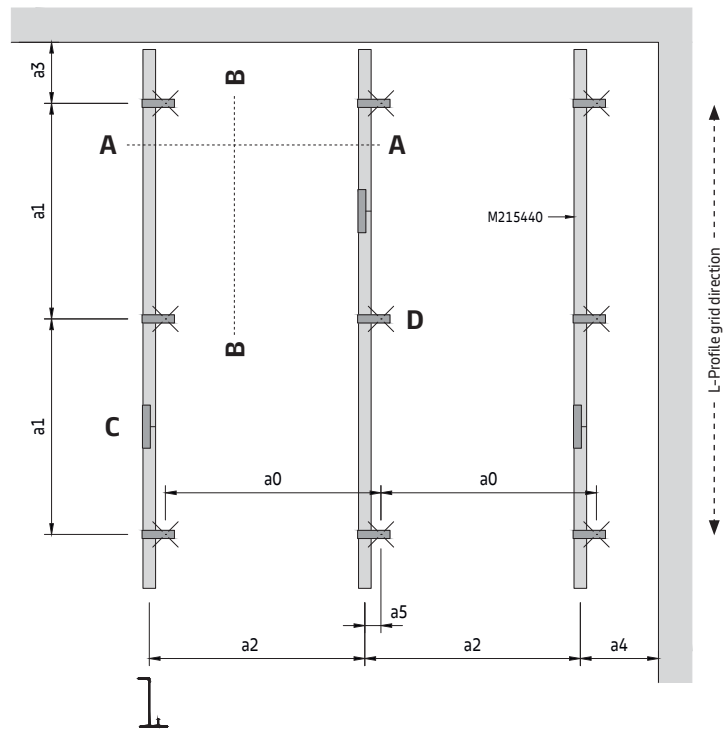

To determine suspension layout

The module length (M) of the requested ceiling is equal to the distance between the DP12 A-Bar centres (a2).

On the appropriate spacing table, read down the column headed (a2) to the required module length then read across to determine the suspension point spacing (a0) and direct hanger spacing (a1).

The shown values are maximum allowed distances and can be reduced but not exceeded.

Detail C

Splice connection

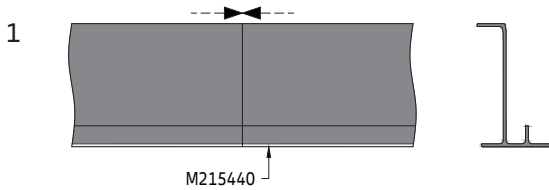

Once the L-Profiles are installed, the ends should be brought together without a gap.

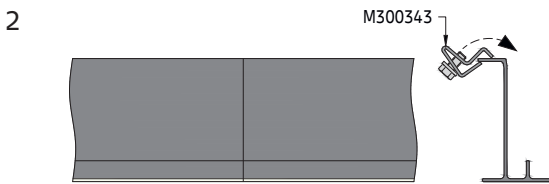

The connectors for the L-Profiles must be inserted from above.

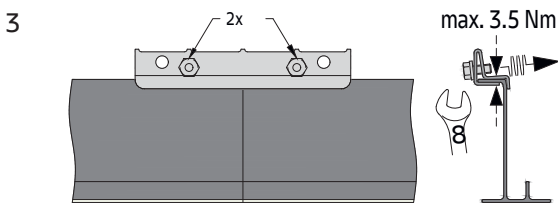

Use the bolts to secure the connector. Stagger the joints.

Detail D

Direct hanger installation

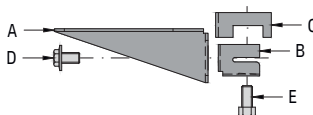

The direct hanger consists of five pre-assembled components (A, B, C, D, E).

Part A is attached to the soffit first. The distance from the L-Profile to the attachment point must not exceed 70 mm.

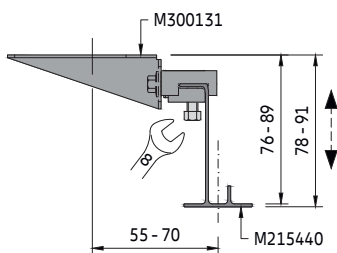

Part B is not tightened, so the L-Profile can be inserted horizontally.

Tightening the bolts (part D, E) creates a stable connection. Before that, the height should be set up and part C inserted from above. Part C is positioned between part A and B and prevents the L-Profile from falling out of the hanger.

Optional Installation

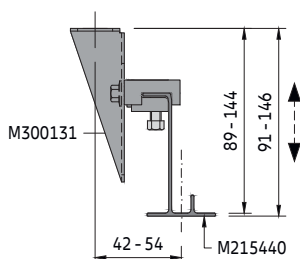

The distance between the L-Profiles should be measured exactly, otherwise the panels are difficult to install and elements could fall out.

The direct hanger can optionally also be installed vertically. To do this, the components must first be disassembled. The shorter side of part A is then attached to the soffit.

Detail E

Panel insertion

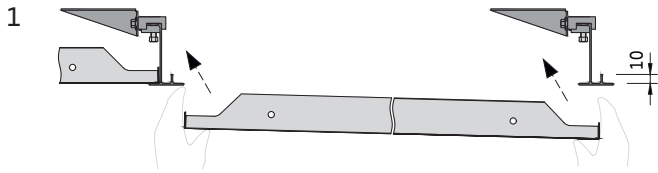

The L-Profile was designed asymmetrically with an additional upstand of 10 mm. As a result, the panels are a little shorter and require less height when installing and extracting.

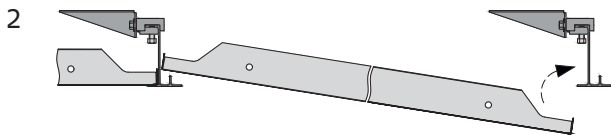

Insert the panel first on the side where the upstand of the L-Profile is, followed by the opposite side.

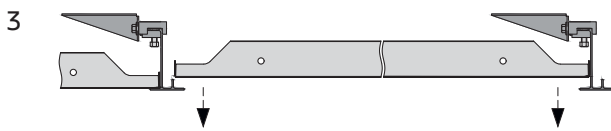

The panel is placed horizontally on the L-Profiles.



Continue with the next panel.

Panel extraction



With a closed ceiling, any panel can be removed as long as there are no obstacles such as service integrations, etc.

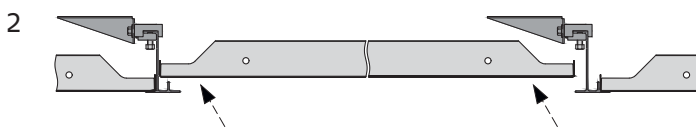

Lift the panel and move it to the direction where the L-Profile upstand is.

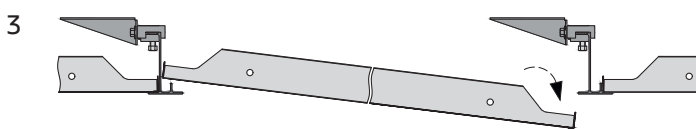

Lower the opposite side.

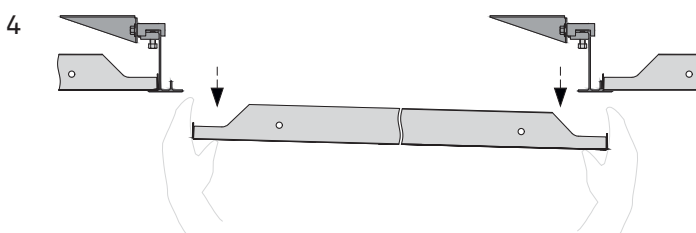

Remove it downwards and store the panel in a safe place so that it cannot be damaged.

Installation sequence

Recommendend

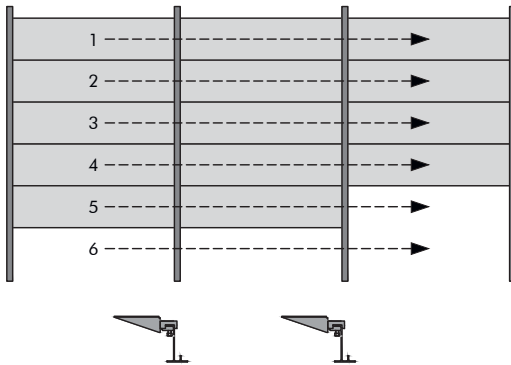

Not recommended

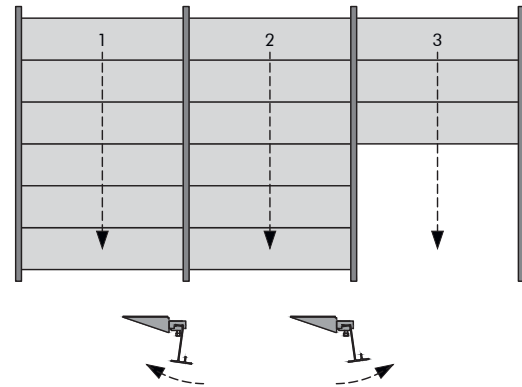

Due to the asymmetric load, the L-Profiles could twist and the panel rows could fall down. Especially with the optional installation, where the direct hanger is installed vertically. This increases leverage.

Material required per m² (no waste included)

System without additional load [pcs/m²]

Components		a2 [mm]	1200	1600	1800	2000	2400	2800	3100	3300
M215440	L-Profile RAL 9010		0.21	0.16	0.14	0.13	0.10	0.09	0.08	0.08
M300131	Direct hanger for L-Profile		0.56	0.42	0.56	0.63	0.69	0.60	0.54	0.51
M300343	Splice connector for L-Profile		0.21	0.16	0.14	0.13	0.11	0.09	0.09	0.08

The shown quantities are theoretical and based on an ideal layout, without considering the actual room layout. The ideal layout is based on a calculation of 10 x 10 m (100 m²). This calculation does not allow any damage, spare nor wastage. The final quantities and type of suspension have to be checked before ordering. Soffit and wall fixings by others.

Not including perimeter trims, optional security brackets and extraction tools.

METAL B-L 302

U-Profile primary grid + Bandraaster secondary grid
Exposed linear grid solution for indoor applications

General information

- Exposed lay-in linear grid system for large rooms
- For perpendicular installation on U-Profile primary grid
- Bandraaster 100 mm in RAL 9010 made of galvanised steel (colour options on request)
- Typical ceiling weight 8.0 – 9.5 kg/m² (indicative value for unperforated panels, without additional load)
- Panels are easily installed and fully demountable
- Tartan grid layout option

Isometric view

Select the suspension option E1 - E4.
Perimeter solutions on separate datasheet.

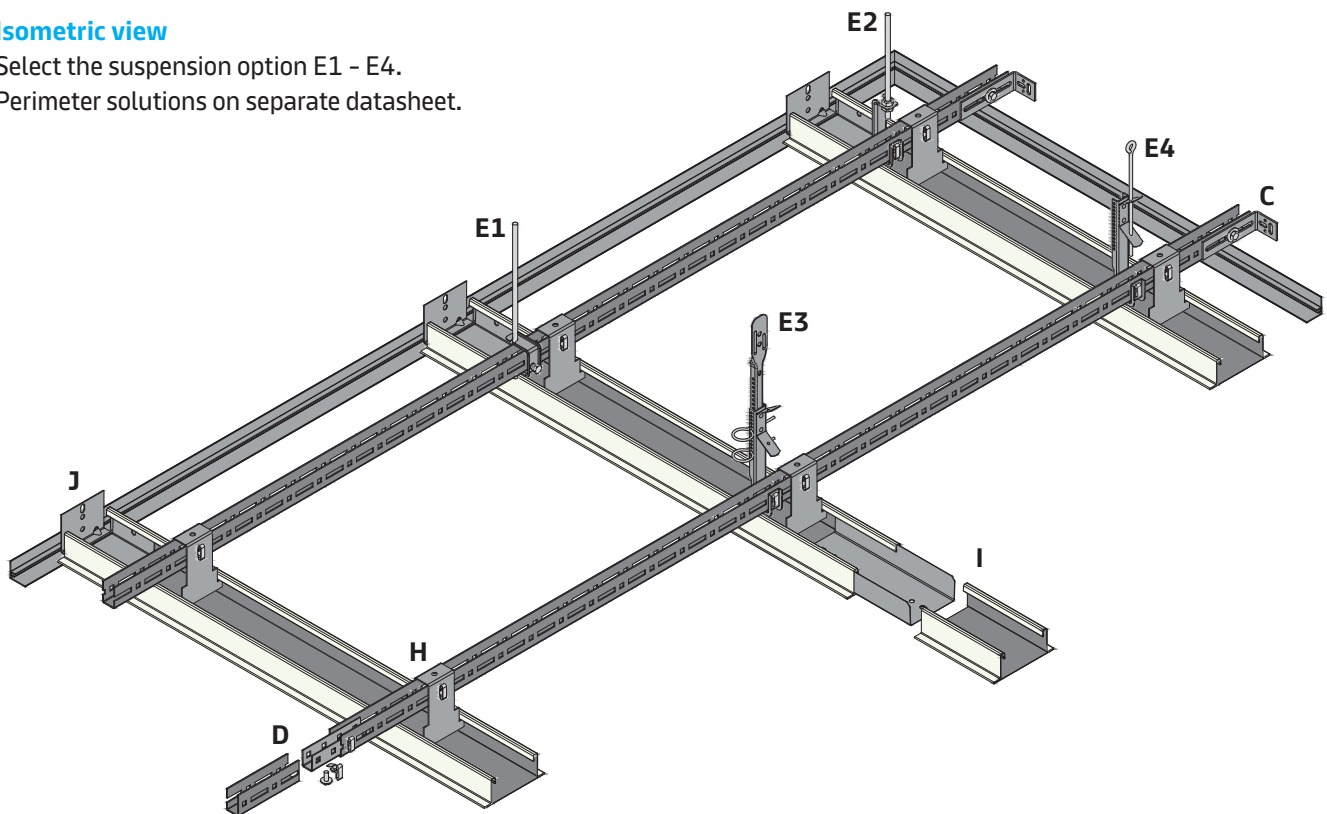

Vario Design & bespoke layout options

Vario Design

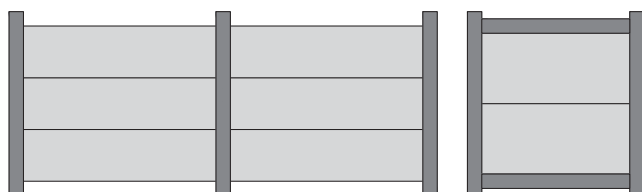

Bespoke (on request)

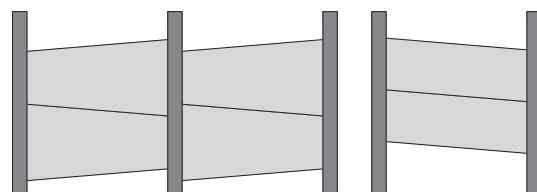

Section F

Example with suspension option E1

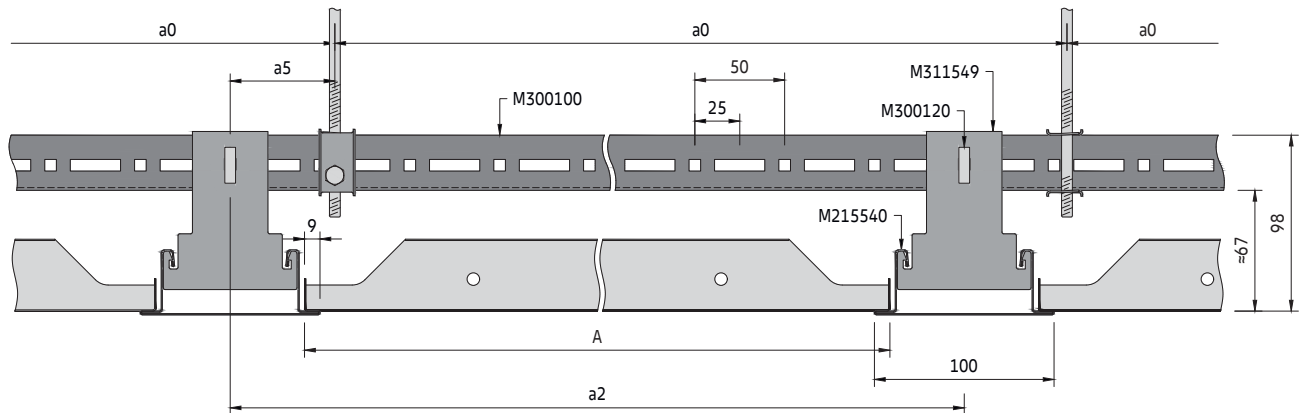

Section G

Example with suspension option E1

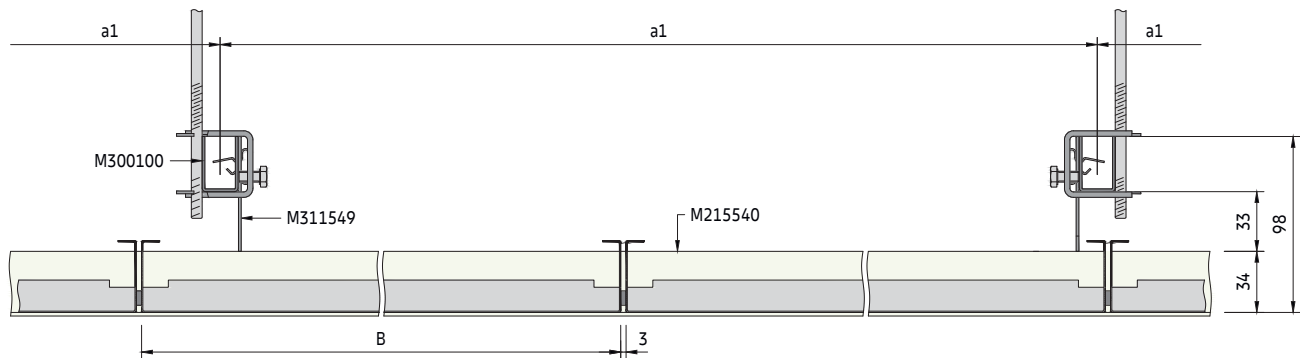

Panels supplied as standard with a 3 mm gasket on one long side to improve the visual appearance. Optionally panels can be installed without a gasket.

Secondary grid components

Standard components

- A361005 Wall anchor for Bandraster 100 mm
- M215540 Bandraster 100 mm RAL 9010
- A361003 Splice connector for Bandraster 100 mm
- M300120 Plug-in clip for U-Profile
- M311549 Hanger for Bandraster 100 mm

Optional components

- A361004 Cross connector for Bandraster 100 mm
- M311191 Self-drilling screw 3.5 x 9.5 mm
- M900000 Black gasket 8x3 mm (spare roll)

See U-Profile primary grid for primary grid components

Bandraster 100 mm secondary grid

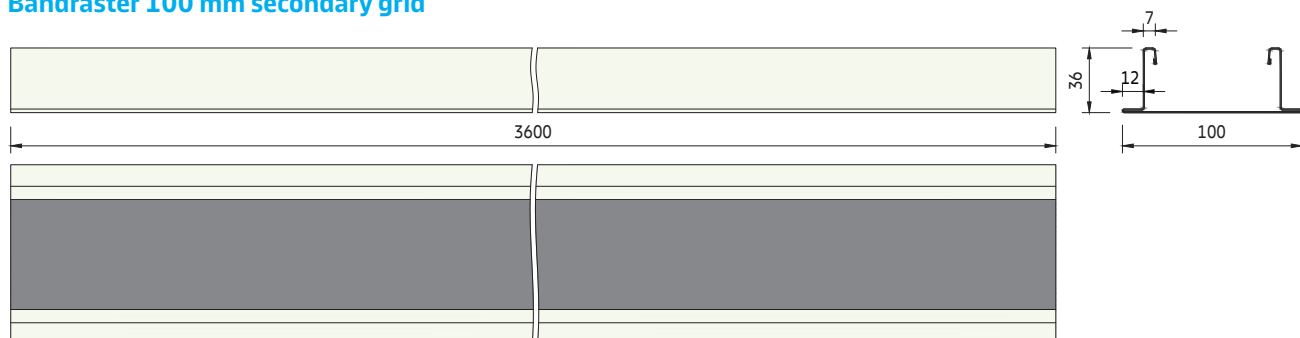

Spacing

a2 [mm]	System without additional load		System with additional load +4 kg/m ²		System with additional load +6 kg/m ²	
	a0 [mm]	a1 [mm]	a0 [mm]	a1 [mm]	a0 [mm]	a1 [mm]
600	1200	1900	1200	1900	1200	1700
650	1300	1900	1300	1700	1300	1450
700	1400	1900	700	1750	700	1700
750	1500	1900	750	1700	750	1650
800	1600	1650	800	1650	800	1600
850	850	1800	850	1600	850	1550
900	900	1750	900	1550	900	1500
950	950	1700	950	1500	950	1450
1000	1000	1650	1000	1500	1000	1400
1050	1050	1600	1050	1450	1050	1400
1100	1100	1600	1100	1400	1100	1350
1150	1150	1550	1150	1400	1150	1300
1200	1200	1500	1200	1350	1200	1300
1250	1250	1500	1250	1300	1250	1250
1300	1300	1450	1300	1300	1300	1250
1350	1350	1400	1350	1250	1350	1200
1400	1400	1400	1400	1250	1400	1150
1450	1450	1350	1450	1200	1450	1100
1500	1500	1350	1500	1200	1500	1000
1550	1550	1350	1550	1100	1550	950
1600	1600	1300	1600	1050	1600	850
1650	1650	1300	1650	1000	1650	800
1700	1700	1250	1700	900	1700	750
1750	1750	1250	1750	800	1750	700
1800	1800	1150	1800	750	1800	600
1850	1850	1050	1850	650	1850	550
1900	1900	950	1900	600	1900	500
1950	975	1200	975	1050	975	1000
2000	1000	1150	1000	1050	1000	1000
2050	1025	1150	1025	1050	1025	1000
2100	1050	1150	1050	1000	1050	950
2150	1075	1150	1075	1000	1075	950
2200	1100	1100	1100	1000	1100	950
2250	1125	1100	1125	1000	1125	950
2300	1150	1100	1150	950	1150	950
2350	1175	1100	1175	950	1175	900
2400	1200	1050	1200	950	1200	900
2450	1225	1050	1225	950	-	-
2500	1250	1050	1250	900	-	-
2600	1300	1000	1300	900	-	-
2700	1350	1000	1350	900	-	-
2800	1400	950	1400	850	-	-
2900	1450	950	1450	850	-	-
3000	1500	950	1500	850	-	-
3100	1550	900	1550	800	-	-
3200	1600	900	1600	800	-	-
3300	1650	900	1650	800	-	-

Parameters

- a0 Distance between U-Profile suspension points = max. 1900 mm
- a1 Max. distance between U-Profiles
- a2 Distance between Bandraster 100 mm
- a3 Distance from wall = max. 200 mm
- a4 Distance from wall = max. panel length
- a5 Distance from U-Profile suspension point to hanger = max. 100 mm
- M Module size = Bandraster width + panel length - 18 mm / panel width + gasket
- A Panel length = min. 600 / max. 3300 mm
- B Panel width = min. 247 / max. 1350 mm

Typical grid layout

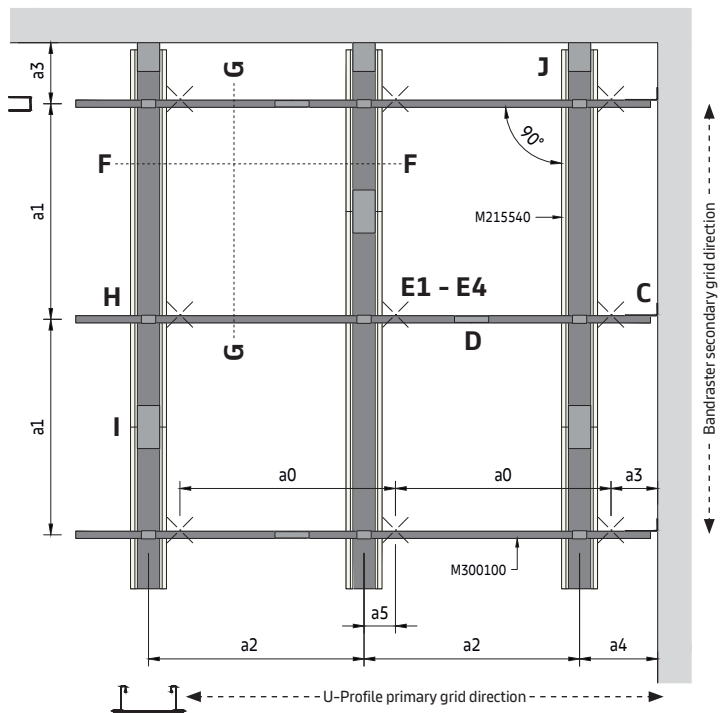

To determine suspension layout

The module length (M) of the requested ceiling is equal to the distance between the Bandraster centres (a2).

On the appropriate spacing table, read down the column headed (a2) to the required module length then read across to determine the suspension point spacing (a0) and U-Profile spacing (a1).

The shown values are maximum allowed distances and can be reduced but not exceeded.

Detail H

Hanger installation

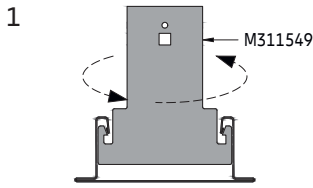

Twist the hanger into the Bandrastrer from above.

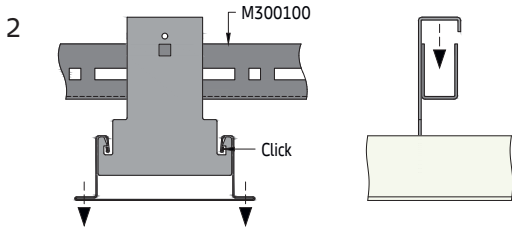

Hook the Bandrastrer with the hangers on the U-Profile and pull the Bandrastrer carefully down until it snaps in (click).

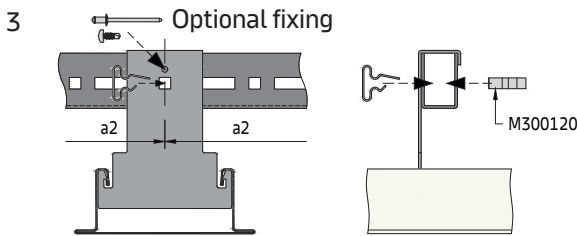

Fix hanger with plug-in clips at the specified module spacing (inserted vertically or horizontally). If the panel size does not fit with the modulation of the U-Profile (25 mm increments), the plug-in clip needs to be inserted into a long hole. The hanger position can alternatively be fixed by using a pop-rivet or self-drilling screw.

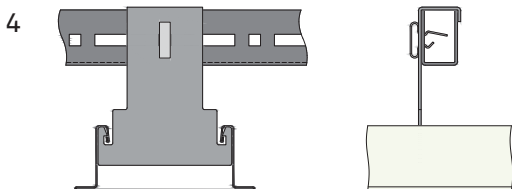

The Bandrastrer is now locked in position.

Detail I

Splice connection

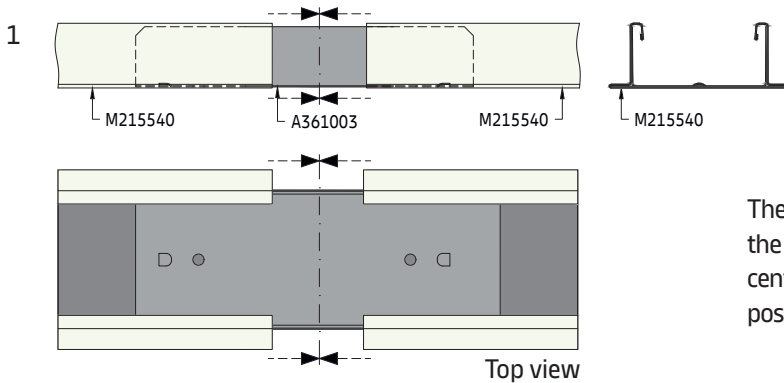

The connectors for the Bandrastrer must be inserted from the end. Make sure the connector is centred. To make centring easier, you can use a screwdriver to adjust the position using the small tabs on the back of the connector.



The ends of the Bandrastrer should be brought together without a gap. Stagger the joints.

METAL B-L 302
D02.003

Detail J

Wall anchor installation

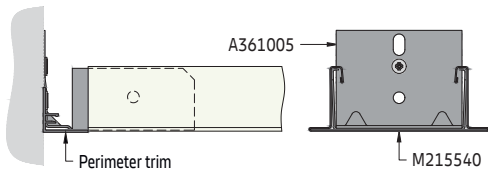

The wall anchor prevents the Bandraister from swinging and thus contributes to the safe installation of the substructure. The wall anchor has no load-bearing function and is only attached to one end of the room to secure the Bandraister.

Detail K

Cross-connector installation for tartan grid layout option

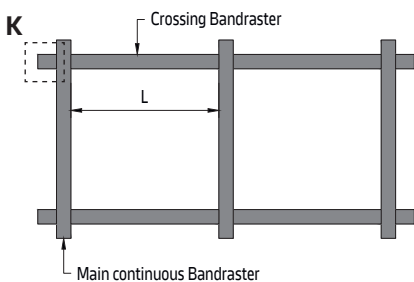

With the cross-connector, a tartan grid layout can be simulated without using crossing-boxes. Bandraister cut to length are installed across the continuous Bandraister.

Crossing Bandraister (L) = module length - Bandraister width 100 mm

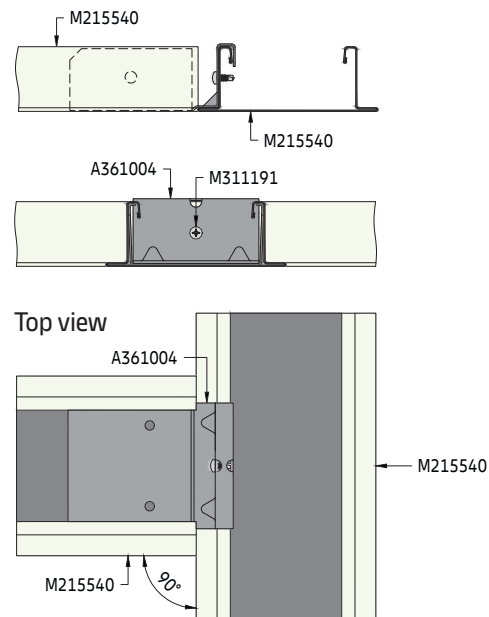

Material required per m² (no waste included)
System without additional load [pcs/m²]

Components		a2 [mm]	1200	1600	1800	2000	2400	2800	3100	3300
A361003	Splice connector for Bandraister 100 mm		0.24	0.18	0.16	0.14	0.12	0.10	0.09	0.09
A361005	Wall anchor for Bandraister 100 mm		0.18	0.14	0.12	0.12	0.10	0.08	0.08	0.08
M215540	Bandraister 100 mm RAL 9010		0.29	0.22	0.19	0.17	0.15	0.13	0.11	0.11
M300100	U-Profile		0.18	0.21	0.23	0.23	0.26	0.28	0.30	0.30
M300119	Splice connector for U-Profile		0.18	0.21	0.24	0.24	0.26	0.29	0.30	0.30
M300120	Plug-in clip for U-Profile		0.92	0.91	0.97	0.92	0.92	0.96	0.96	0.94
M300140	Wall anchor		0.07	0.08	0.09	0.09	0.10	0.11	0.12	0.12
M311103	Hexagonal nut M6		0.10	0.10	0.10	0.10	0.10	0.10	0.20	0.20
M311105	Washer		0.10	0.10	0.10	0.10	0.10	0.10	0.20	0.20
M311303	Hexagonal bolt M6 x 16 mm		0.10	0.10	0.10	0.10	0.10	0.10	0.20	0.20
M311549	Hanger for Bandraister 100 mm		0.56	0.49	0.49	0.44	0.40	0.38	0.36	0.34
Various	Suspension points (E1 - E4)		0.56	0.49	0.49	0.87	0.80	0.76	0.72	0.68

The shown quantities are theoretical and based on an ideal layout, without considering the actual room layout. The ideal layout is based on a calculation of 10 x 10 m (100 m²). This calculation does not allow any damage, spare nor wastage. The final quantities and type of suspension have to be checked before ordering. Soffit and wall fixings by others. Not including perimeter trims, optional security brackets and extraction tools.

Detail L

Panel insertion

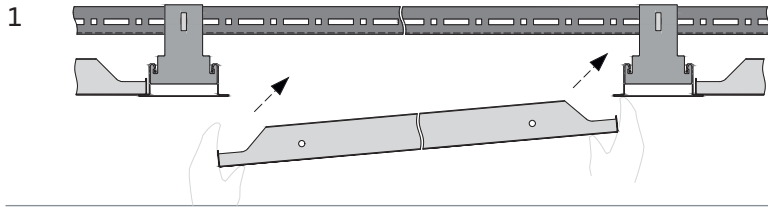

Insert the panel at a slight angle, above the Bandraster.

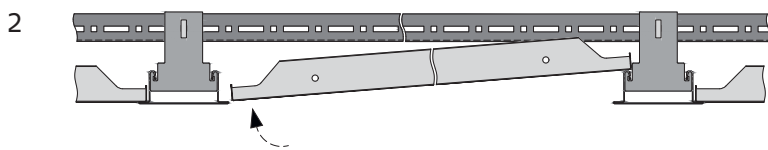

Lift up the opposite end of the panel above the leg of the Bandraster.

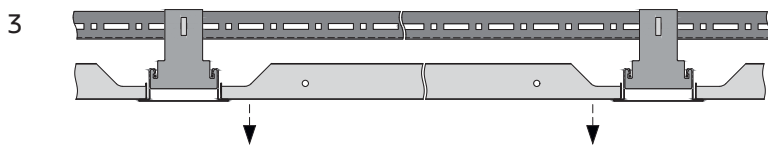

Rest the panel on the Bandraster.

Panel extraction



With a closed ceiling, any panel can be removed as long as there are no obstacles such as service integrations, etc.

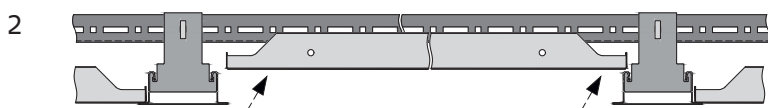

Lift the panel above the Bandraster.

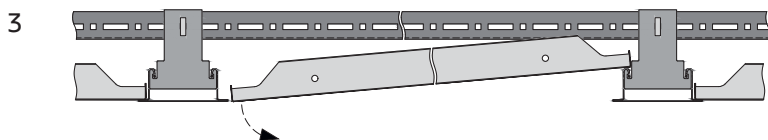

Lower the opposite side.

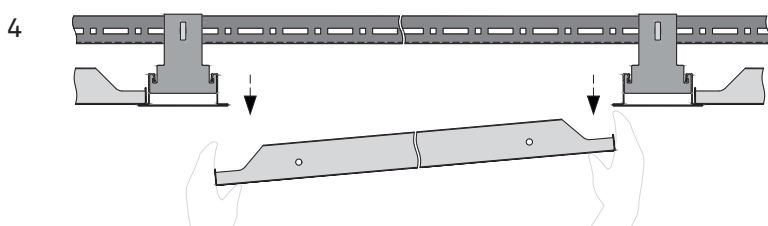

Remove it downwards and store the panel in a safe place so that it cannot be damaged.

METAL B-H 300

U-Profile primary grid + C-Profile secondary grid
Exposed linear grid solution for indoor applications

General information

- Exposed hook-on linear grid system for large rooms
- For perpendicular installation on U-Profile primary grid
- C-Profile 100 mm in RAL 9010 made of galvanised steel (further sizes, cut-outs and colour options on request)
- Typical ceiling weight 8.0 - 9.5 kg/m² (indicative value for unperforated panels, without additional load)
- Panels are easily installed and fully demountable
- Various hinge-down and swing-down options
- Seismic design application available, see separate document
- Suitable for large panel sizes and chilled ceilings
- Tartan grid layout option

Isometric view

Select the suspension option E1 - E4.
Perimeter solutions on separate datasheet.

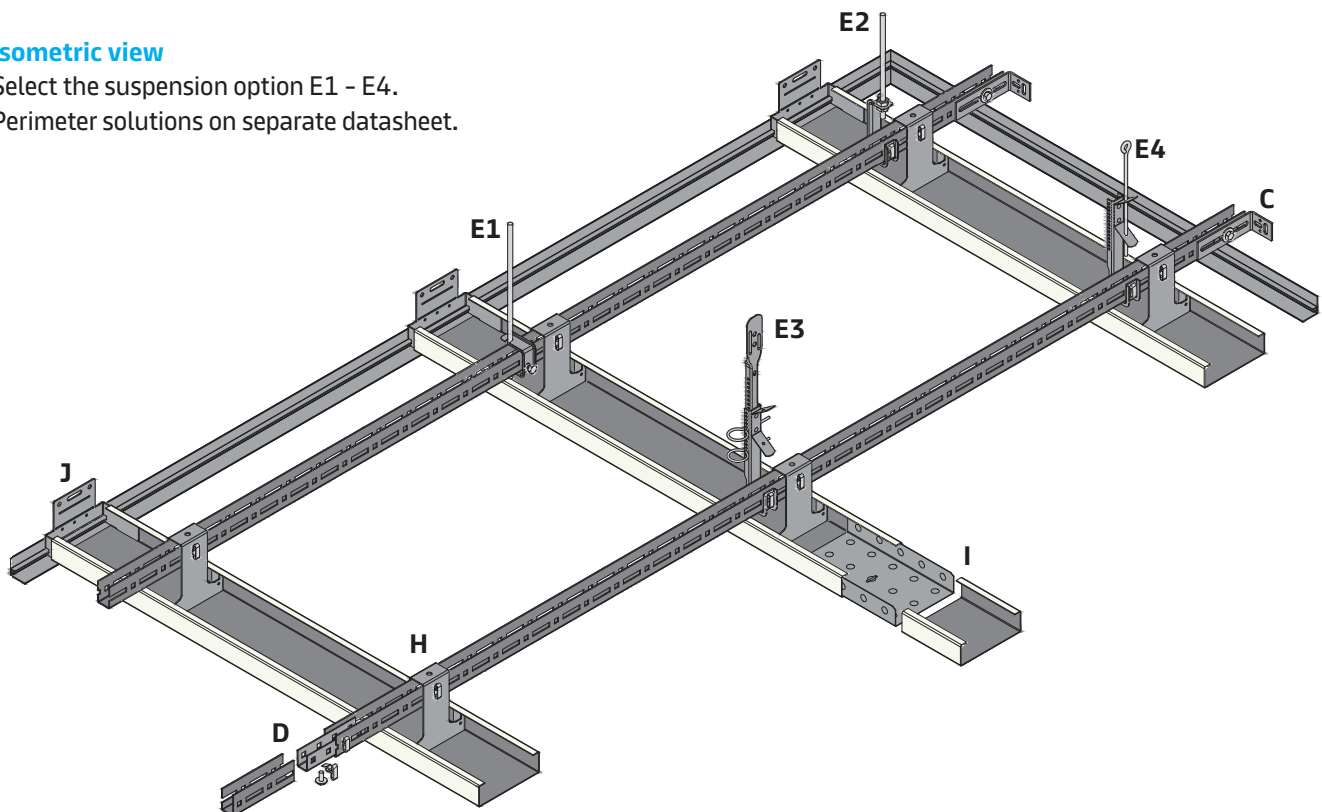

Vario Design & bespoke layout options

Vario Design

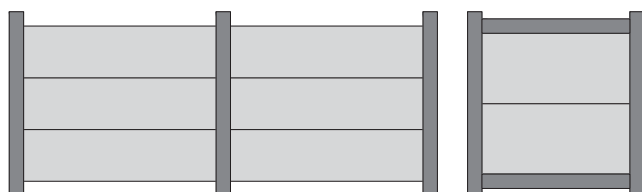

Bespoke (on request)

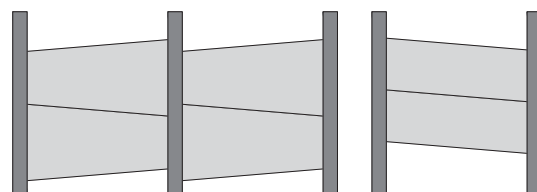

Section F

Example with suspension option E1

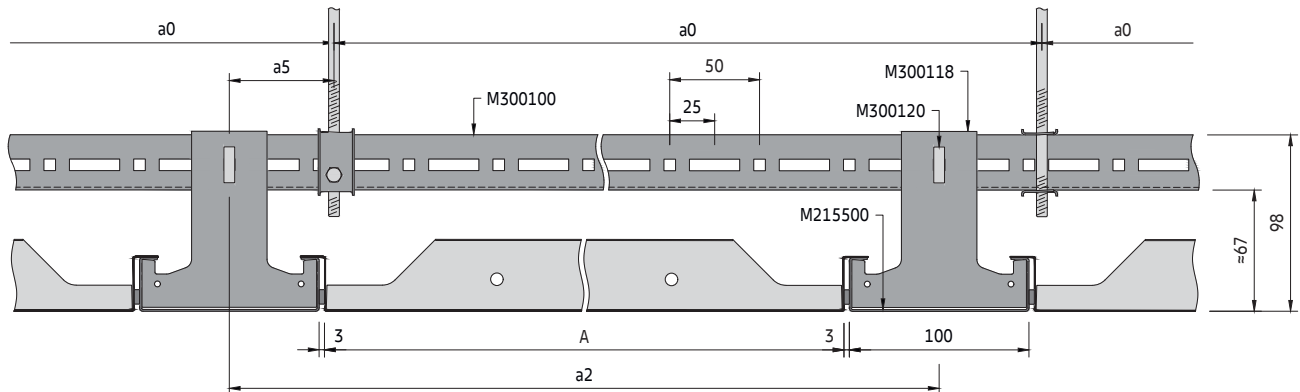

Section G

Example with suspension option E1

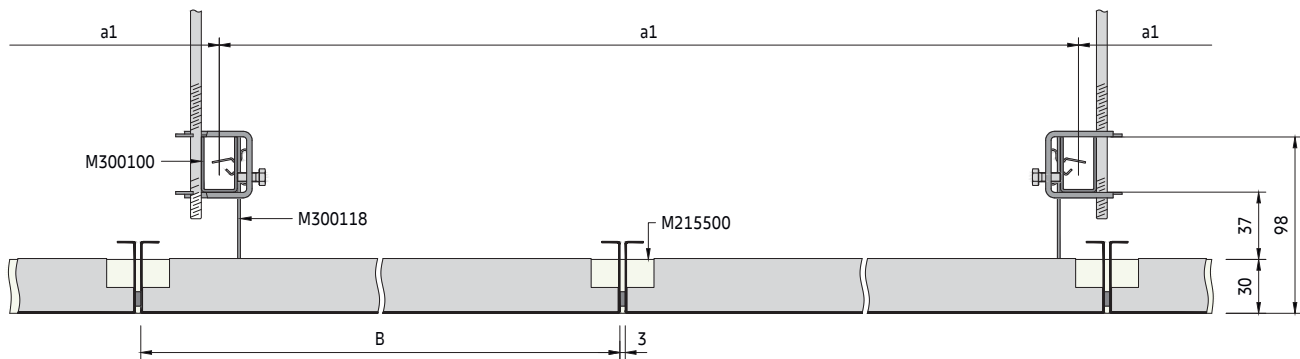

Panels supplied as standard with a 3 mm gasket on one long and both short sides to improve the visual appearance. Optionally panels can be supplied without a gasket (except SWING panel option).

Secondary grid components

Standard components

- M215500 C-Profile 100 mm RAL 9010
- M300118 Hanger for C-Profile 100 mm
- M300120 Plug-in clip for U-Profile
- M300144 Wall anchor for C-Profile 100 mm
- M311067 Splice connector for C-Profile 100 mm

Optional components

- M311034 Extraction tool (Swing function)
- M311191 Self-drilling screw 3.5 x 9.5 mm
- M900000 Black gasket 8x3 mm (spare roll)

See primary angle primary grid for primary grid components

C-Profile 100 mm secondary grid

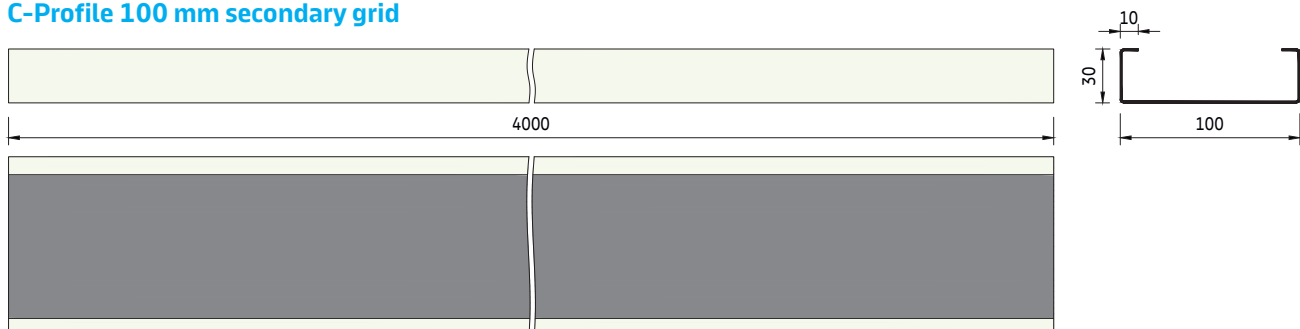

Spacing

a2 [mm]	System without additional load		System with additional load +4 kg/m ²		System with additional load +6 kg/m ²	
	a0 [mm]	a1 [mm]	a0 [mm]	a1 [mm]	a0 [mm]	a1 [mm]
600	1200	1900	1200	1900	1200	1650
650	1300	1900	1300	1650	1300	1400
700	1400	1900	700	1900	700	1900
750	1500	1850	750	1900	750	1850
800	1600	1500	800	1850	800	1800
850	850	1900	850	1800	850	1750
900	900	1900	900	1750	900	1700
950	950	1900	950	1700	950	1650
1000	1000	1850	1000	1650	1000	1600
1050	1050	1800	1050	1650	1050	1550
1100	1100	1800	1100	1600	1100	1550
1150	1150	1750	1150	1550	1150	1500
1200	1200	1700	1200	1550	1200	1450
1250	1250	1700	1250	1500	1250	1450
1300	1300	1650	1300	1450	1300	1350
1350	1350	1600	1350	1450	1350	1250
1400	1400	1550	1400	1350	1400	1150
1450	1450	1550	1450	1250	1450	1050
1500	1500	1500	1500	1200	1500	1000
1550	1550	1500	1550	1100	1550	900
1600	1600	1450	1600	1000	1600	850
1650	1650	1450	1650	950	1650	800
1700	1700	1350	1700	850	1700	750
1750	1750	1200	1750	800	1750	650
1800	1800	1100	1800	700	1800	600
1850	1850	1000	1850	650	1850	550
1900	1900	950	1900	600	1900	500
1950	975	1350	975	1200	975	1150
2000	1000	1300	1000	1200	1000	1150
2050	1025	1300	1025	1150	1025	1100
2100	1050	1300	1050	1150	1050	1100
2150	1075	1250	1075	1150	1075	1100
2200	1100	1250	1100	1100	1100	1050
2250	1125	1250	1125	1100	1125	1050
2300	1150	1250	1150	1100	1150	1050
2350	1175	1200	1175	1100	1175	1050
2400	1200	1200	1200	1050	1200	1050
2450	1225	1200	1225	1050	-	-
2500	1250	1150	1250	1050	-	-
2600	1300	1150	1300	1000	-	-
2700	1350	1100	1350	1000	-	-
2800	1400	1100	1400	1000	-	-
2900	1450	1100	1450	950	-	-
3000	1500	1050	1500	950	-	-
3100	1550	1050	1550	950	-	-
3200	1600	1050	1600	900	-	-
3300	1650	1000	1650	900	-	-

Parameters

- a0 Distance between U-Profile suspension points = max. 1900 mm
- a1 Max. distance between U-Profiles
- a2 Distance between C-Profiles
- a3 Distance from wall = max. 200 mm
- a4 Distance from wall = max. panel length
- a5 Distance from U-Profile suspension point to hanger = max. 100 mm
- M Module size = C-Profile width + panel length + 2x gasket / panel width + gasket
- A Panel length = min. 600 / max. 3300 mm
- B Panel width = min. 247 / max. 1350 mm

Typical grid layout

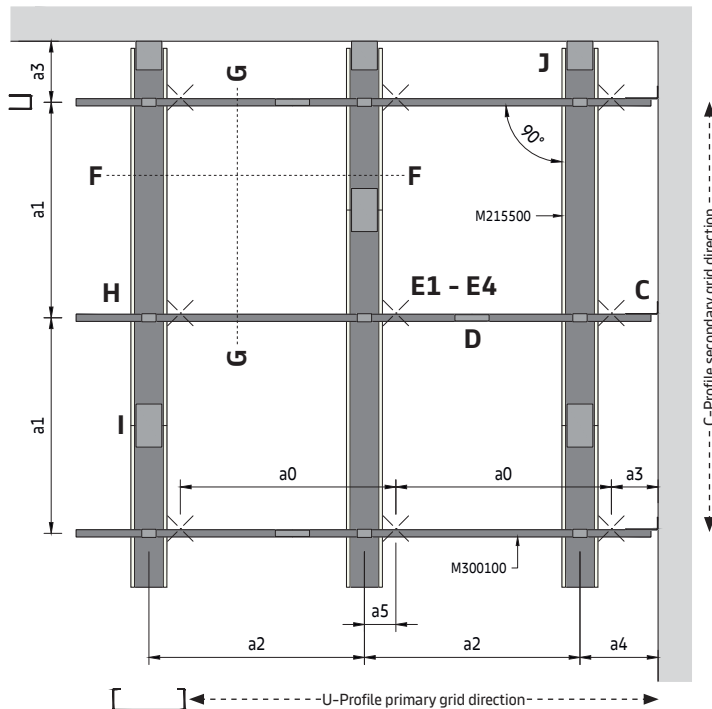

To determine suspension layout

The module length (M) of the requested ceiling is equal to the distance between the C-Profile centres (a2).

On the appropriate spacing table, read down the column headed (a2) to the required module length then read across to determine the suspension point spacing (a0) and U-Profile spacing (a1).

The shown values are maximum allowed distances and can be reduced but not exceeded.

Detail H

Hanger installation

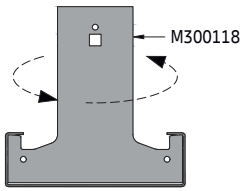
- 1  Twist the hanger on the C-Profile from above.

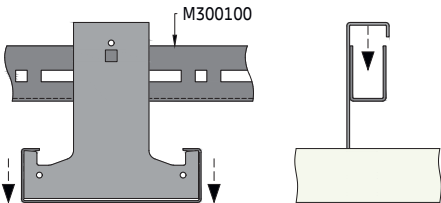
- 2  Hook the C-Profile with the hangers on the U-Profile.

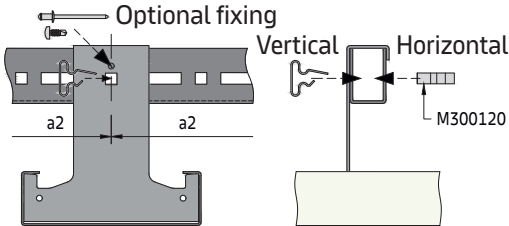
- 3  Fix hanger with plug-in clips at the specified module spacing (inserted vertically or horizontally). If the panel size does not fit with the modulation of the U-Profile (25 mm increments), the plug-in clip needs to be inserted into a long hole. The hanger position can alternatively be fixed by using a pop-rivet or self-drilling screw.

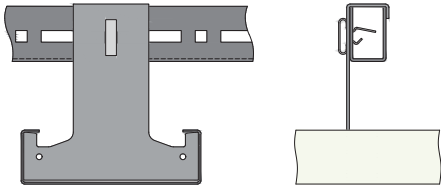
- 4  The C-Profile is now locked in position.

Detail I

Splice connection

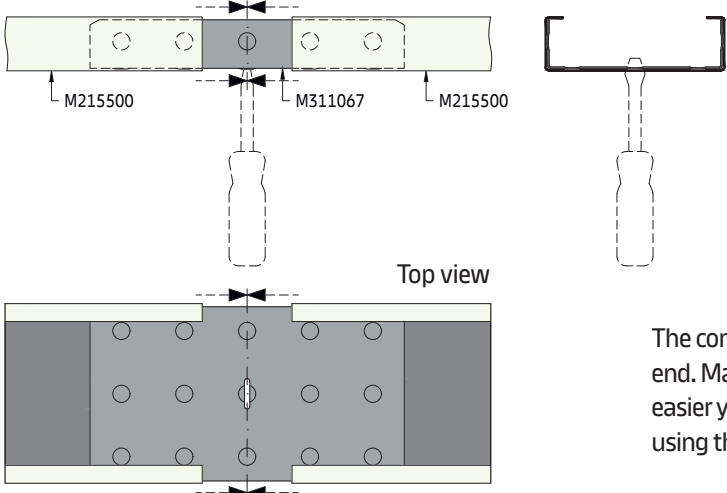
- 1  The connectors for the C-Profile must be inserted from the end. Make sure the connector is centered. To make centring easier you can use a screwdriver to adjust the position using the slot in the connector.

- 2  The ends of the C-Profiles should be brought together without a gap. Stagger the joints.

Detail J

Wall anchor installation

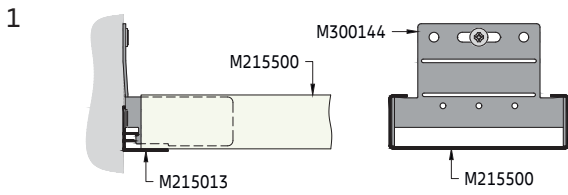

The wall anchor prevents the C-Profile from swinging and thus contributes to the safe installation of the substructure. The wall anchor has no load-bearing function and is only attached to one end of the room to secure the C-Profile.

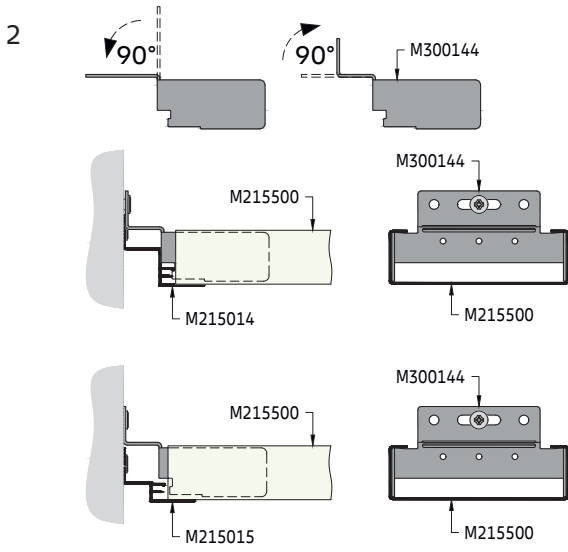

When using a shadowline perimeter trim, the upper part must first be bent 90° down and then 90° up again, so that a step is created.

Detail K

Cross-connector installation for tartan grid layout option

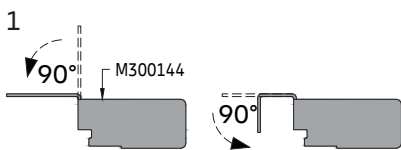

With the cross-connector, a tartan grid layout can be simulated without using crossing-boxes. Bend the upper part of the hanger twice by 90° until a hook is formed.

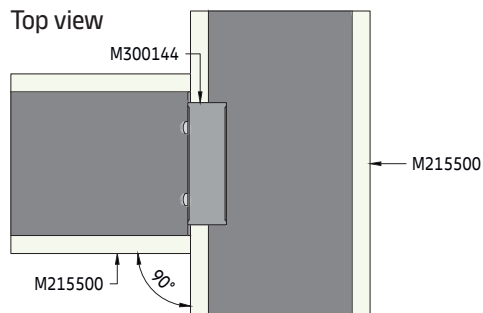
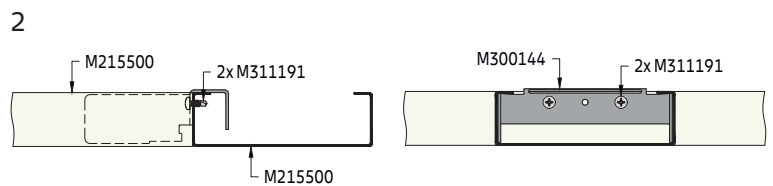
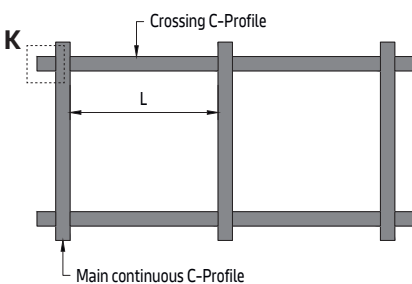

Use two self-drilling screws to attach the hanger to the C-Profile. C-Profiles cut to length are installed across the continuous C-Profiles.

Crossing C-Profile (L) = module length - C-Profile width

Detail L

Panel insertion

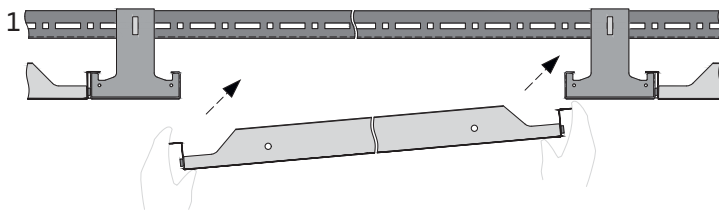

Insert the panel at a slight angle, above the C-Profile.

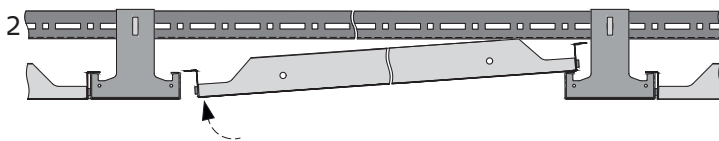

Lift up the opposite end of the panel above the opposite C-Profile.

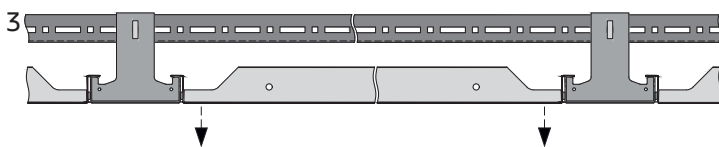

Rest the panel on the C-Profiles.

Panel extraction



With a closed ceiling, any panel can be removed as long as there are no obstacles such as service integrations, etc.

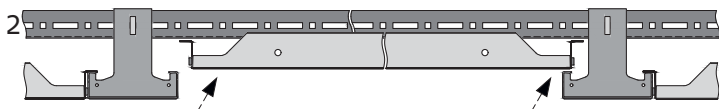

Lift the panel above the C-Profile.

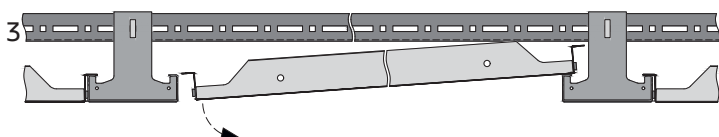

Lower the opposite side.

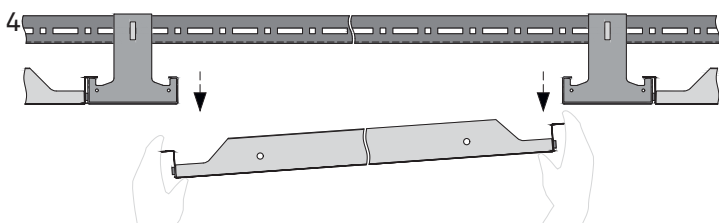

Remove it downwards and store the panel in a safe place so that it cannot be damaged.

Detail M

METAL B-H 300 EASY

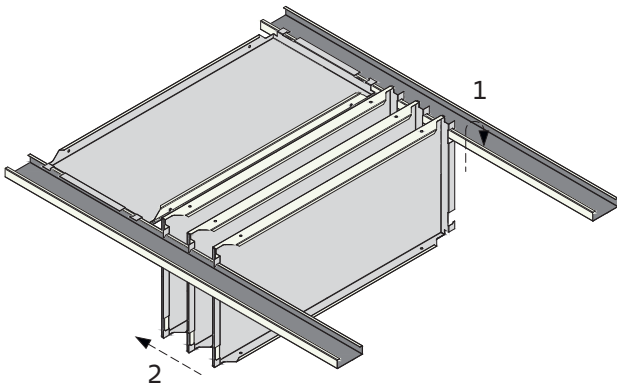

- 1 Extract the panel as shown under Detail L and hang it back vertically on the C-Profile. The panels hinge-down from the long side. Move the panel aside to allow access to the plenum.
- 2 Up to three adjacent panels can be suspended at once. Do not exceed this number, otherwise the weight would be too high on the C-Profile.

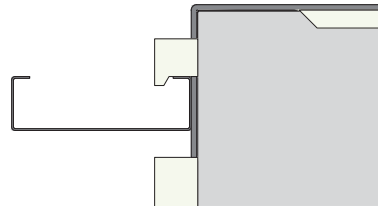

METAL B-H 300 SWING

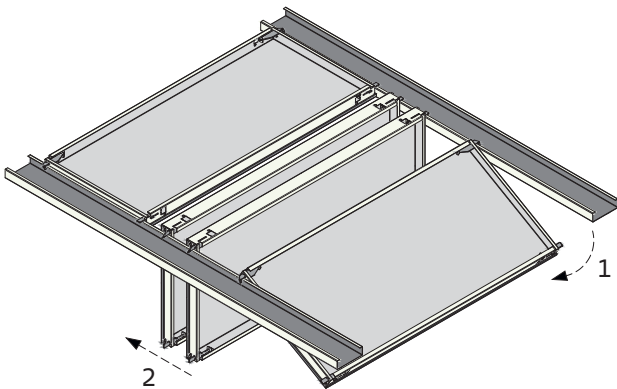

- 1 Use the extraction tool to release the brackets on the panel. Swing the panel down carefully. Insert the extraction tool carefully to avoid damaging the gasket. The panels swing-down from the long side.
- 2 Move the panel aside to allow access to the plenum. Up to three adjacent panels can be suspended at once. Do not exceed this number, otherwise the weight would be too high on the C-Profile.

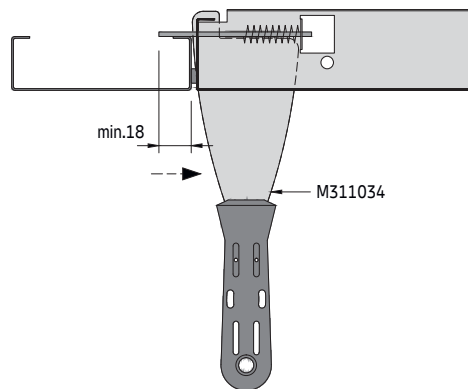

METAL B-H 300 SWING panels only available with 3 mm gasket on the long and both short sides. Be careful that the brackets do not scratch the C-Profile

METAL B-H 300 HOOK

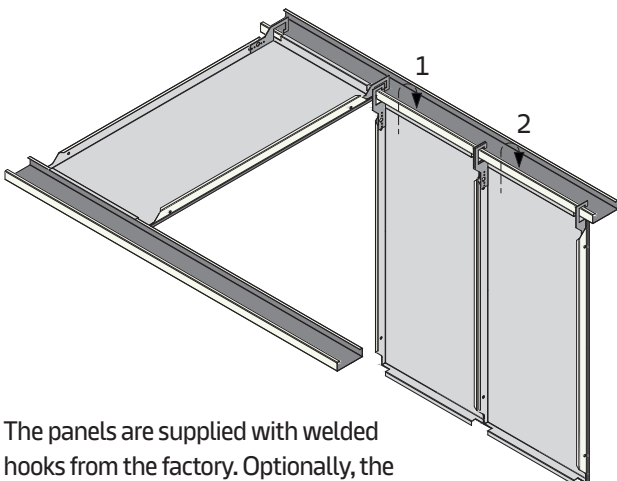

The panels are supplied with welded hooks from the factory. Optionally, the hooks can be fixed on site with two rivets.

- 1 Extract the panel as shown under Detail L and hang it back vertically on the C-Profile. The panels hinge-down from the short side.
- 2 Up to three adjacent panels can be suspended at once. Do not exceed this number, otherwise the weight would be too high on the C-Profile.

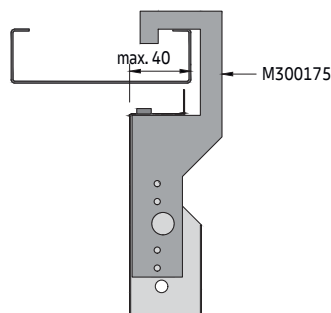

Material required per m² (no waste included)
System without additional load [pcs/m²]

Components		a2 [mm]	1200	1600	1800	2000	2400	2800	3100	3300
M215500	C-Profile 100 mm RAL 9010		0.21	0.16	0.14	0.13	0.10	0.09	0.08	0.08
M300100	U-Profile		0.16	0.18	0.24	0.21	0.22	0.24	0.26	0.27
M300118	Hanger for C-Profile 100 mm		0.50	0.44	0.51	0.39	0.35	0.33	0.31	0.31
M300119	Splice connector for U-Profile		0.21	0.19	0.25	0.21	0.23	0.25	0.26	0.27
M300120	Plug-in clip for U-Profile		0.82	0.82	0.10	0.81	0.81	0.83	0.83	0.85
M300140	Wall anchor		0.06	0.07	0.10	0.08	0.09	0.10	0.10	0.11
M300144	Wall anchor for C-Profile 100 mm		0.18	0.14	0.12	0.12	0.10	0.08	0.08	0.08
M311067	Splice connector for C-Profile 100 mm		0.21	0.16	0.14	0.13	0.11	0.09	0.09	0.08
M311103	Hexagonal nut M6		0.10	0.10	0.10	0.10	0.10	0.10	0.10	0.20
M311105	Washer		0.10	0.10	0.10	0.10	0.10	0.10	0.10	0.20
M311303	Hexagonal bolt M6 x 16 mm		0.10	0.10	0.10	0.10	0.10	0.10	0.10	0.20
Various	Suspension points (E1 - E4)		0.50	0.44	0.51	0.77	0.70	0.65	0.62	0.61

The shown quantities are theoretical and based on an ideal layout, without considering the actual room layout. The ideal layout is based on a calculation of 10 x 10 m (100 m²). This calculation does not allow any damage, spare nor wastage. The final quantities and type of suspension have to be checked before ordering. Soffit and wall fixings by others. Not including perimeter trims, optional security brackets and extraction tools.

METAL B-H 300

Direct suspended C-Profile
Exposed linear grid solution for indoor applications

General information

- Exposed hook-on linear grid system for medium rooms
- For perpendicular or radial installation
- C-Profile 100 mm in RAL 9010 made of galvanised steel (further sizes, cut-outs and colour options on request)
- Typical ceiling weight 7.5 - 9.0 kg/m² (indicative value for unperforated panels, without additional load)
- Panels are easily installed and fully demountable
- Various hinge-down and swing-down options
- Suitable for large panel sizes and chilled ceilings
- Tartan grid layout option

Isometric view

Select the suspension option C1 - C2.
Perimeter solutions on separate datasheet.

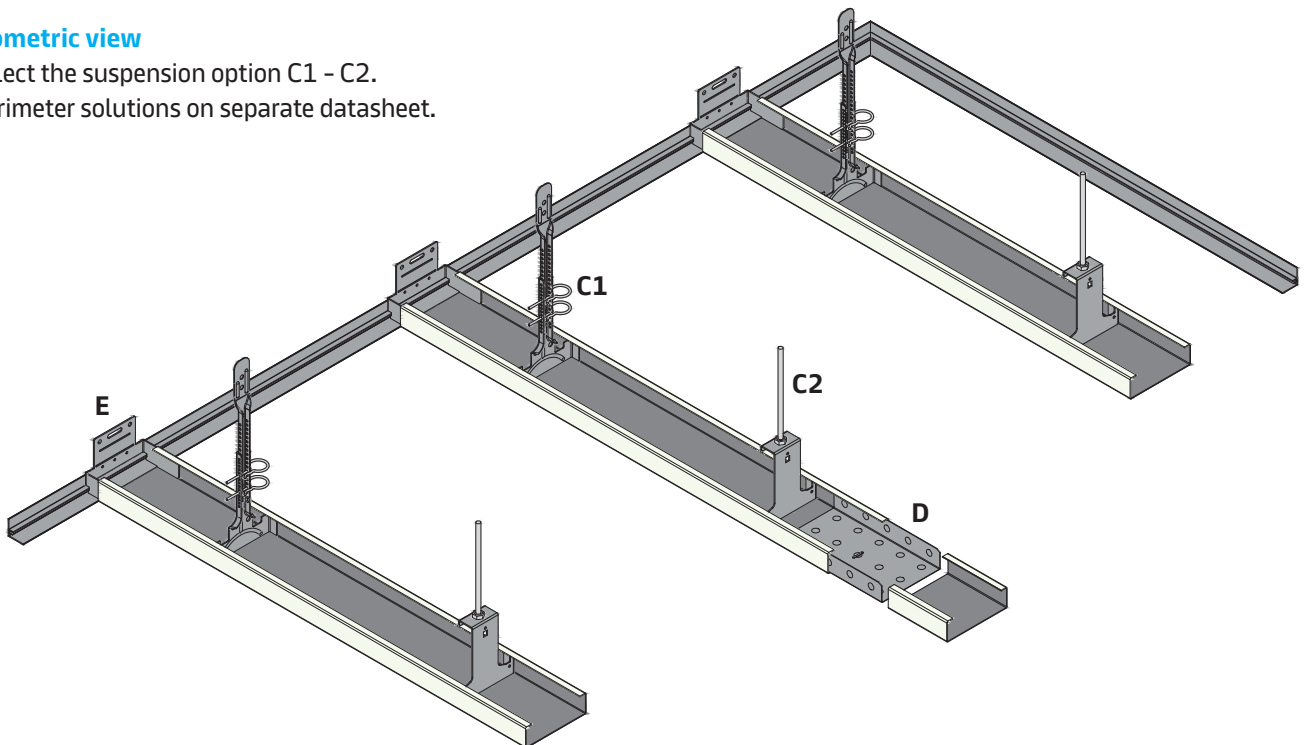

Vario Design & bespoke layout options

Vario Design

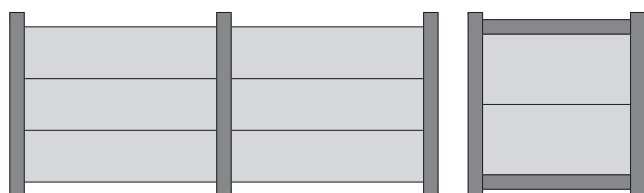

Bespoke (on request)

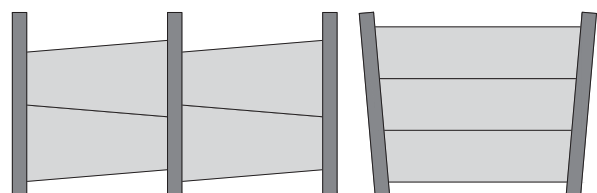

Section A

Example with suspension option C2

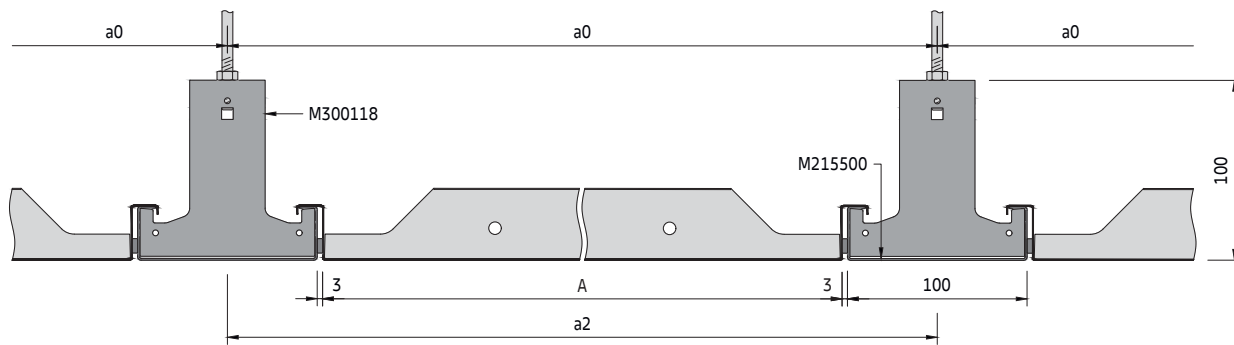

In the case of a direct suspension, the panels are designed with a hook edge (fall 5) to prevent them from falling down.

Section B

Example with suspension option C2

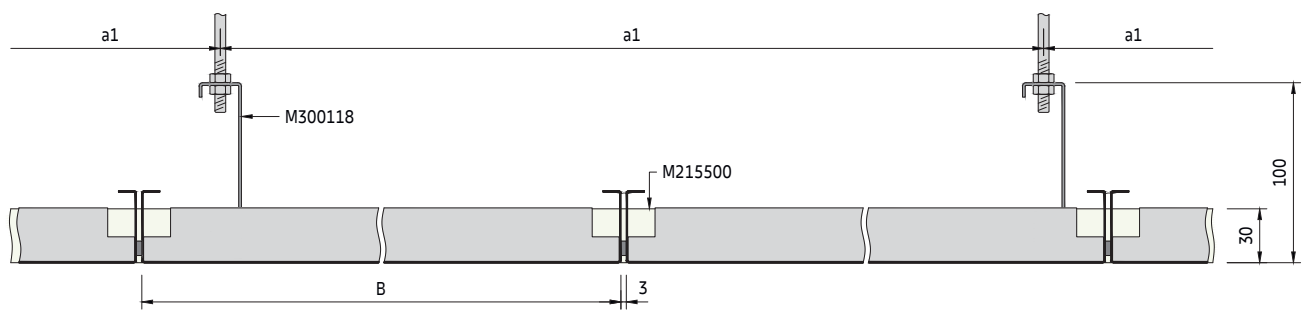

Panels supplied as standard with a 3 mm gasket on one long and both short sides to improve the visual appearance. Optionally panels can be supplied without a gasket (except SWING panel option).

Grid components

Standard components

- M215500 C-Profile 100 mm RAL 9010
- M300144 Wall anchor for C-Profile 100 mm
- M311067 Splice connector for C-Profile 100 mm

Suspension option C2

- M300078 Nonius hanger for C-Profile 100 mm
- - Nonius top part (various lengths)
- M300036 Nonius locking pin

Suspension option C1

- M300118 Hanger for C-Profile 100 mm
- M311101 Threaded rod M6 x 1000 mm
- M311103 Hexagonal nut M6
- M311315 Hexagonal extension nut M6 x 30 mm (optional)
- M311061 Suspension element (optional)

Optional components

- M311034 Extraction tool (Swing function)
- M311191 Self-drilling screw 3.5 x 9.5 mm
- M900000 Black gasket 8x3 mm (spare roll)

C-Profile 100 mm

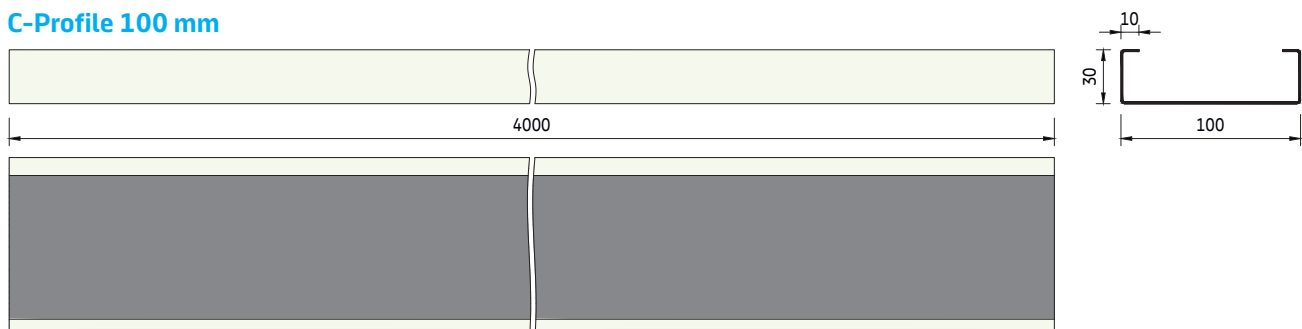

Spacing

a2 [mm]	System without additional load		System with additional load +4 kg/m ²		System with additional load +6 kg/m ²	
	a0 [mm]	a1 [mm]	a0 [mm]	a1 [mm]	a0 [mm]	a1 [mm]
600	1200	1900	1200	1900	1200	1800
650	1300	1900	1300	1650	1300	1550
700	1400	1900	700	1900	700	1800
750	1500	1850	750	1900	750	1800
800	1600	1500	800	1850	800	1750
850	850	1900	850	1800	850	1700
900	900	1900	900	1750	900	1650
950	950	1900	950	1700	950	1600
1000	1000	1850	1000	1650	1000	1550
1050	1050	1800	1050	1650	1050	1550
1100	1100	1800	1100	1600	1100	1500
1150	1150	1750	1150	1550	1150	1450
1200	1200	1700	1200	1550	1200	1450
1250	1250	1700	1250	1500	1250	1400
1300	1300	1650	1300	1450	1300	1350
1350	1350	1600	1350	1450	1350	1350
1400	1400	1550	1400	1350	1400	1250
1450	1450	1550	1450	1250	1450	1150
1500	1500	1500	1500	1200	1500	1100
1550	1550	1500	1550	1100	1550	1000
1600	1600	1450	1600	1000	1600	900
1650	1650	1450	1650	950	1650	850
1700	1700	1350	1700	850	1700	750
1750	1750	1200	1750	800	1750	700
1800	1800	1100	1800	700	1800	600
1850	1850	1000	1850	650	1850	550
1900	1900	950	1900	600	1900	500
1950	975	1350	975	1200	975	1100
2000	1000	1300	1000	1200	1000	1100
2050	1025	1300	1025	1150	1025	1050
2100	1050	1300	1050	1150	1050	1050
2150	1075	1250	1075	1150	1075	1050
2200	1100	1250	1100	1100	1100	1000
2250	1125	1250	1125	1100	1125	1000
2300	1150	1250	1150	1100	1150	1000
2350	1175	1200	1175	1100	1175	1000
2400	1200	1200	1200	1050	1200	950
2450	1225	1200	1225	1050	-	-
2500	1250	1150	1250	1050	-	-
2600	1300	1150	1300	1000	-	-
2700	1350	1100	1350	1000	-	-
2800	1400	1100	1400	1000	-	-
2900	1450	1100	1450	950	-	-
3000	1500	1050	1500	950	-	-
3100	1550	1050	1550	950	-	-
3200	1600	1050	1600	900	-	-
3300	1650	1000	1650	900	-	-

Parameters

- a0 Distance between C-Profile suspension points = max. 1900 mm
- a1 Max. distance between C-Profile hangers
- a2 Distance between C-Profile 100 mm
- a3 Distance from wall = max. 200 mm
- a4 Distance from wall = max. panel length
- M Module size = C-Profile width + panel length + 2x gasket / panel width + gasket
- A Panel length = min. 600 / max. 3300 mm
- B Panel width = min. 247 / max. 1350 mm

Typical grid layout

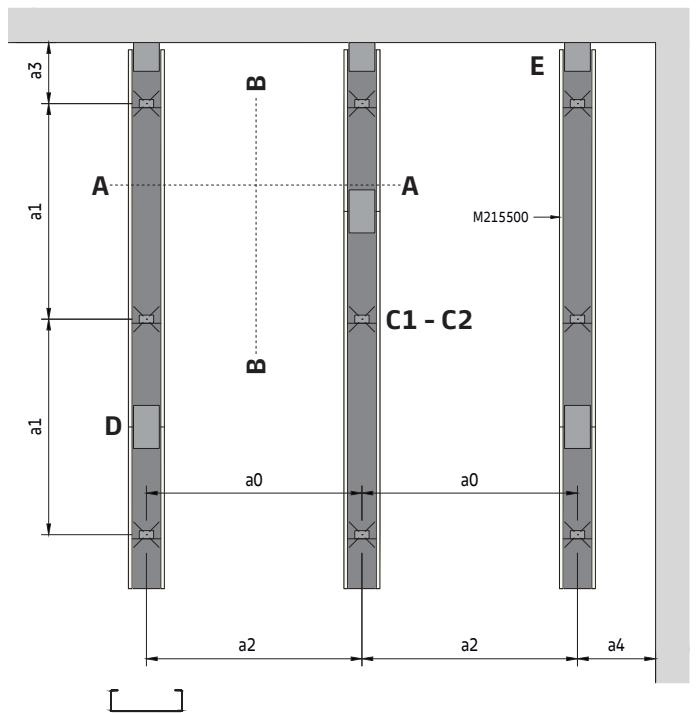

To determine suspension layout

The module length (M) of the requested ceiling is equal to the distance between the DP12 A-Bar centres (a2).

On the appropriate spacing table, read down the column headed (a2) to the required module length then read across to determine the suspension point spacing (a0) and direct hanger spacing (a1).

The shown values are maximum allowed distances and can be reduced but not exceeded.

Detail C

Hanger installation

Option C1

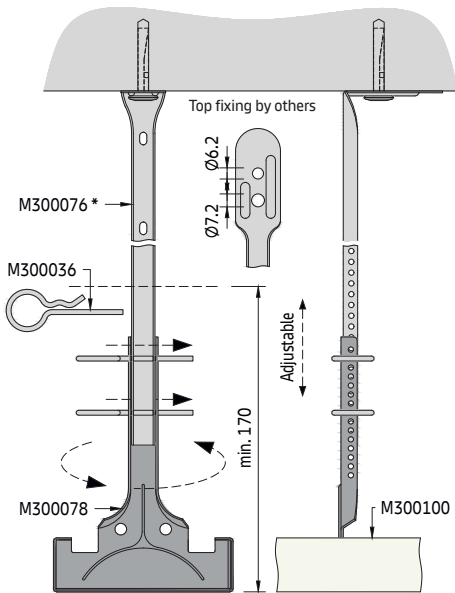

Twist the Nonius hanger on the C-Profile from above. Fix the C-Profile with the Nonius hangers to the Nonius top parts by using Nonius locking pins, 2 pcs.

Please make sure that the elements have an overlap of at least 40 mm.

Option C2

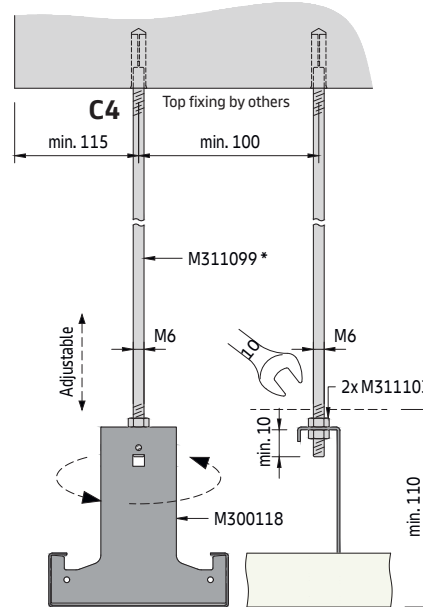

Fix the hanger to the threaded rod, at an angle of approx. 45°. The upper hexagonal nut defines the height of the ceiling, the bottom one is positioned with a small gap between the hanger and the upper hexagonal nut.

Insert the C-Profile from below and twist the hanger to the end position, perpendicular to the C-Profile. Lock the position of the hanger by tighten the bottom hexagonal nut.

Detail C4

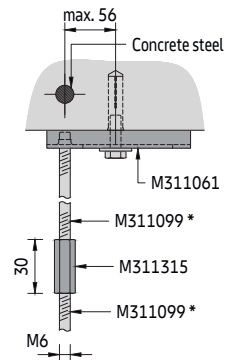

* Various lengths available

Angle bracing option

Detail C3

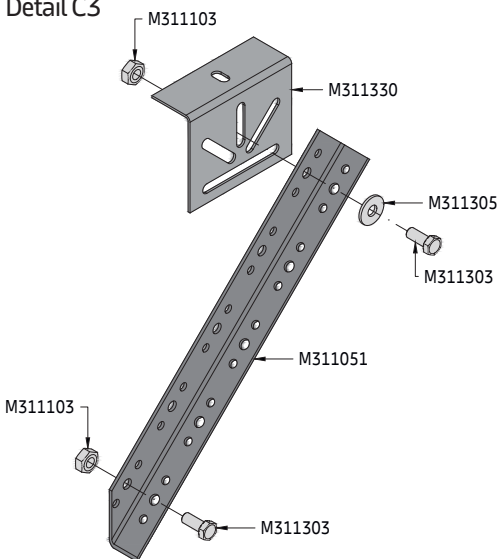

For suspension option C1

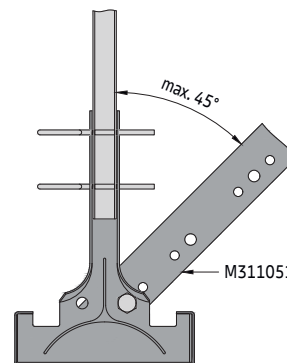

For suspension option C2

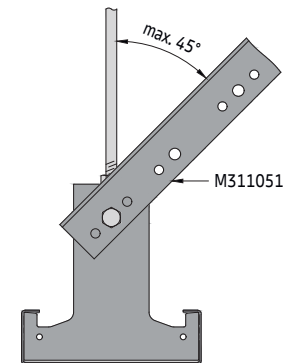

The use of angle bracings is recommended and prevents the C-Profiles from swinging and makes the installation safer. A minimum of two angle bracings per C-Profile row is needed.

Minimum pull-out force per suspension point = 1.25 kN (failure state)

Maximum permissible load per suspension point = 0.50 kN (incl. 2.5 times safety). These values must always be observed and guaranteed by the installation company for each suspension point irrespective of the type of hanger selected.

Detail D

Splice connection

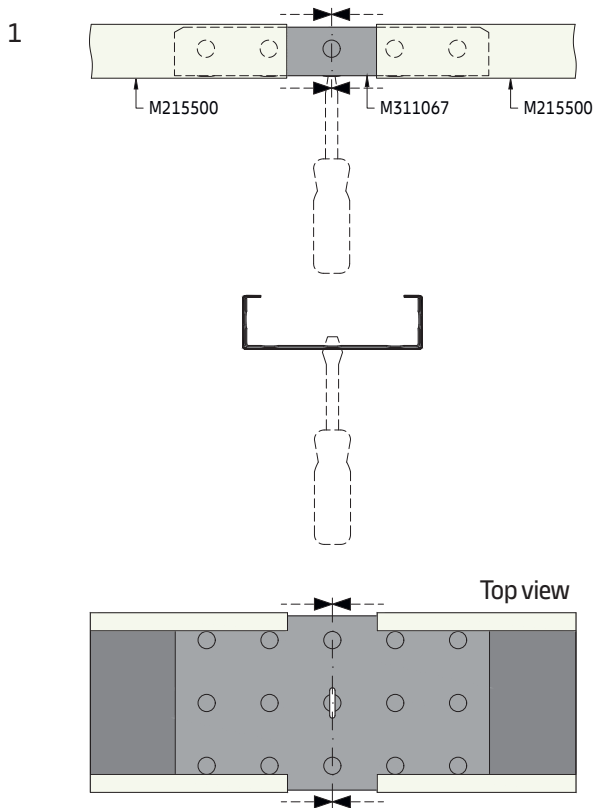

The connectors for the C-Profile must be inserted from the end. Make sure the connector is centred. To make centring easier you can use a screwdriver to adjust the position using the slot in the connector.

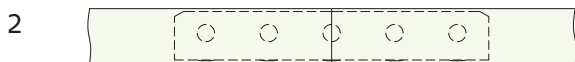

The ends of the C-Profiles should be brought together without a gap. Stagger the joints.

Material required per m² (no waste included)

System without additional load [pcs/m²]

Components		a2 [mm]	1200	1600	1800	2000	2400	2800	3100	3300
M215500	C-Profile 100 mm RAL 9010		0.21	0.16	0.14	0.13	0.10	0.09	0.08	0.08
M300144	Wall anchor for C-Profile 100 mm		0.18	0.14	0.12	0.12	0.10	0.08	0.08	0.08
M311067	Splice connector for C-Profile 100 mm		0.21	0.16	0.14	0.13	0.11	0.09	0.09	0.08
Various	Suspension points (E1 - E4)		0.50	0.44	0.51	0.77	0.70	0.65	0.62	0.61

The shown quantities are theoretical and based on an ideal layout, without considering the actual room layout. The ideal layout is based on a calculation of 10 x 10 m (100 m²). This calculation does not allow any damage, spare nor wastage. The final quantities and type of suspension have to be checked before ordering. Soffit and wall fixings by others.

Not including perimeter trims, optional security brackets and extraction tools.

Detail E

Wall anchor installation

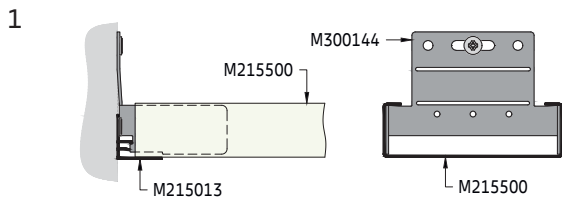

The wall anchor prevents the C-Profile from swinging and this contributes to the safe installation of the substructure. The wall anchor has no load-bearing function and is only attached to one end of the room to secure the C-Profile.

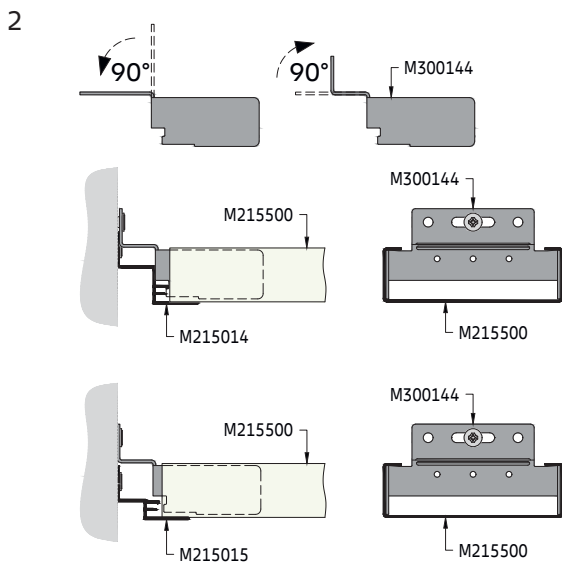

When using a shadowline perimeter trim, the upper part must first be bent 90° down and then 90° up again, so that a step is created.

Detail F

Cross-connector installation for tartan grid layout option

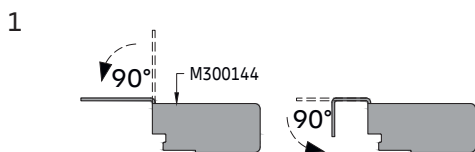

With the cross-connector, a tartan grid layout can be simulated without using crossing-boxes. Bend the upper part of the hanger twice by 90° until a hook is formed.

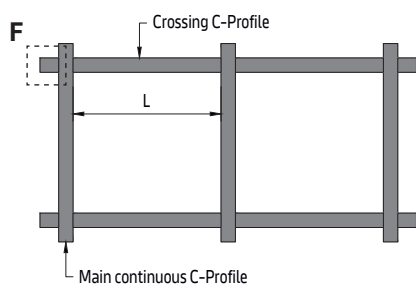
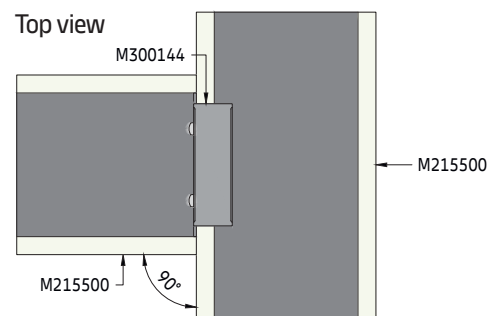
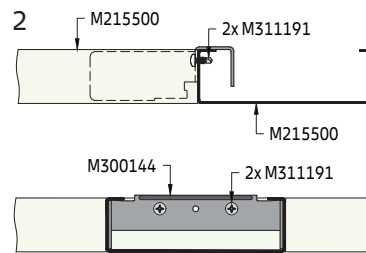

Use two self-drilling screws to attach the hanger to the C-Profile. C-Profiles cut to length are installed across the continuous C-Profiles.

Crossing C-Profile (L) = module length - C-Profile width

Detail G

Panel insertion

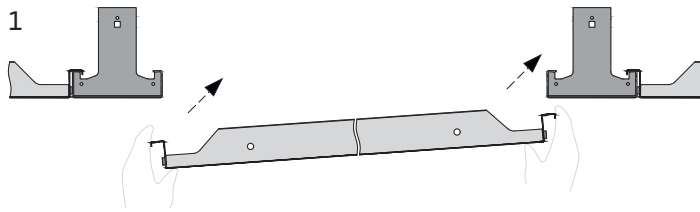

Insert the panel at a slight angle, above the C-Profile.

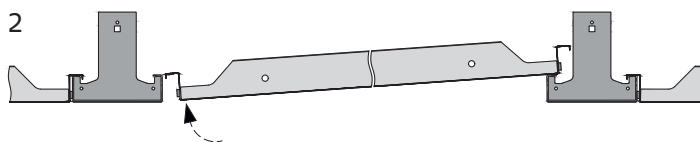

Lift up the opposite end of the panel above the opposite C-Profile.

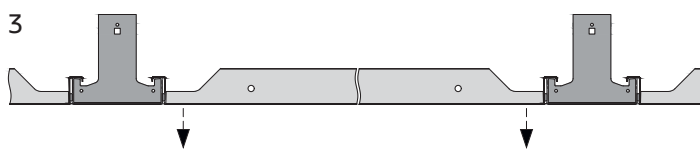

Rest the panel on the C-Profiles.

Panel extraction



With a closed ceiling, any panel can be removed as long as there are no obstacles such as service integrations, etc.

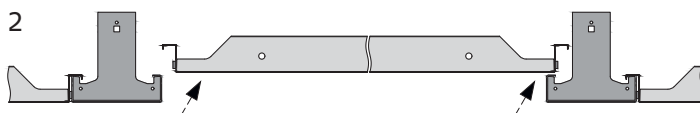

Lift the panel above the C-Profile.

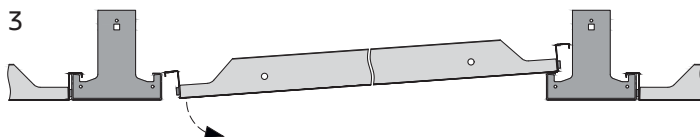

Lower the opposite side.

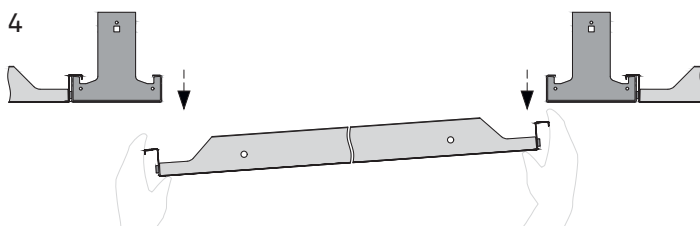

Remove it downwards and store the panel in a safe place so that it cannot be damaged.

Detail H

METAL B-H 300 EASY

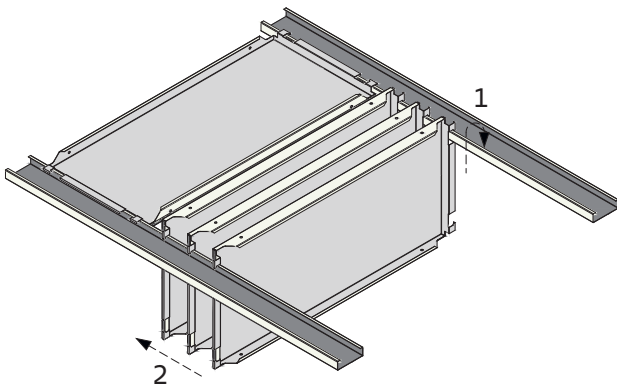

- 1 Extract the panel as shown under Detail I and hang it back vertically on the C-Profile. The panels hinge-down from the long side.
- 2 Move the panel aside to allow access to the plenum. Up to three adjacent panels can be suspended at once. Do not exceed this number, otherwise the weight would be too high on the C-Profile.

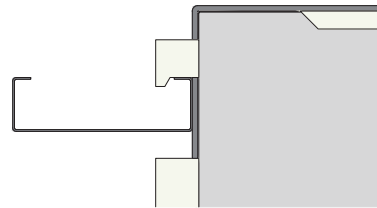

METAL B-H 300 SWING

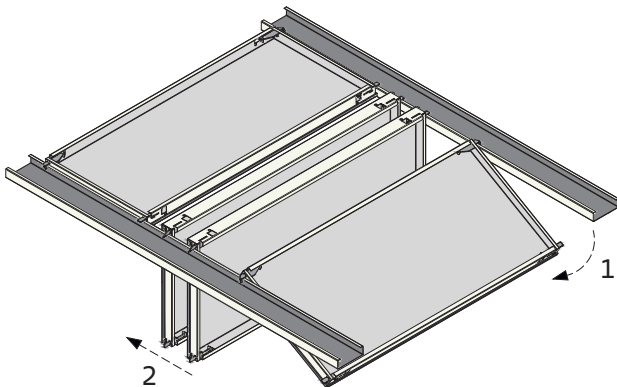

- 1 Use the extraction tool to release the brackets on the panel. Swing the panel down carefully. Insert the extraction tool carefully to avoid damaging the gasket.
- 2 The panels swing-down from the long side. Move the panel aside to allow access to the plenum. Up to three adjacent panels can be suspended at once. Do not exceed this number, otherwise the weight would be too high on the C-Profile.

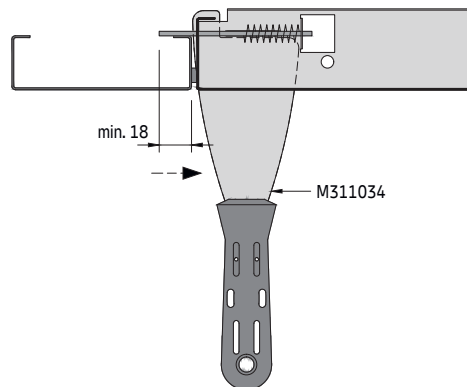

METAL B-H 300 SWING panels only available with 3 mm gasket on the long and both short sides.

Be careful that the brackets do not scratch the C-Profile. The use of angle bracings is strongly recommended.

METAL B-H 300 HOOK

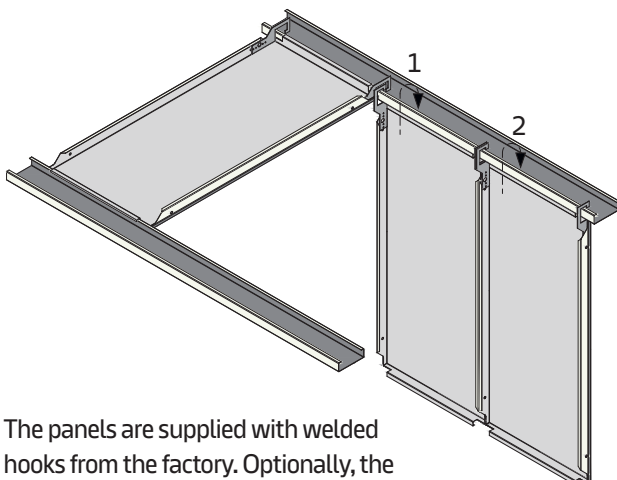

- 1 Extract the panel as shown under Detail L and hang it back vertically on the C-Profile. The panels hinge-down from the short side.
- 2 Up to three adjacent panels can be suspended at once. Do not exceed this number, otherwise the weight would be too high on the C-Profile.

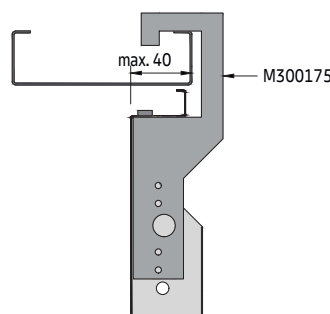

The panels are supplied with welded hooks from the factory. Optionally, the hooks can be fixed on site with two rivets.

METAL K-H 400

Crossing box + C-Profile

Exposed tartan grid solution for indoor applications

General information

- Exposed hook-on tartan grid system for large rooms
- Crossing box and C-Profile 100 mm in RAL 9010 made of galvanised steel (further sizes, cut-outs and colour options on request)
- Typical ceiling weight 8.0 - 9.0 kg/m² (indicative value for unperforated panels, without additional load)
- Panels are easily installed and fully demountable
- Various hinge-down and swing-down options
- Suitable for large panel sizes and chilled ceilings

Isometric view

Perimeter solutions on separate datasheet.

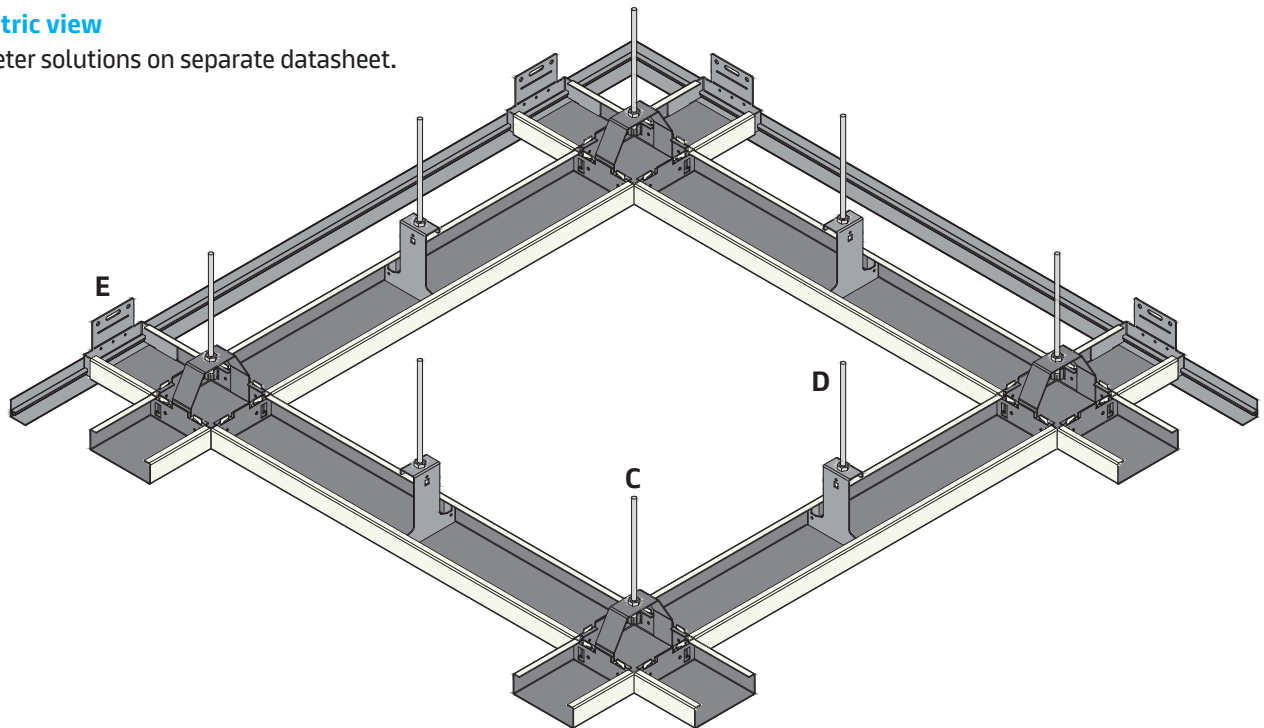

Vario Design & bespoke layout options

Vario Design



Bespoke (on request)

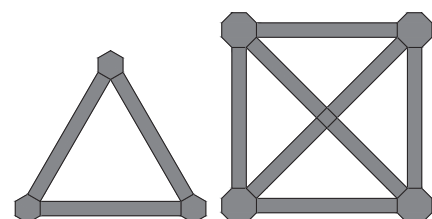

Section A

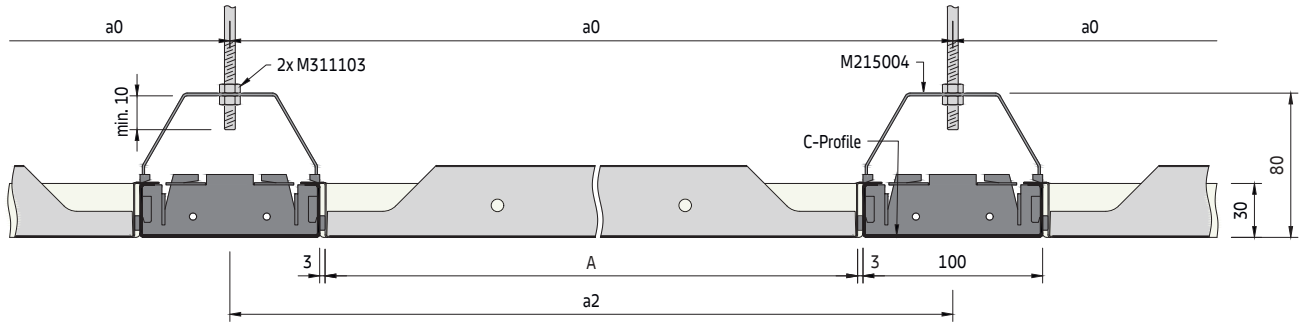

Section B

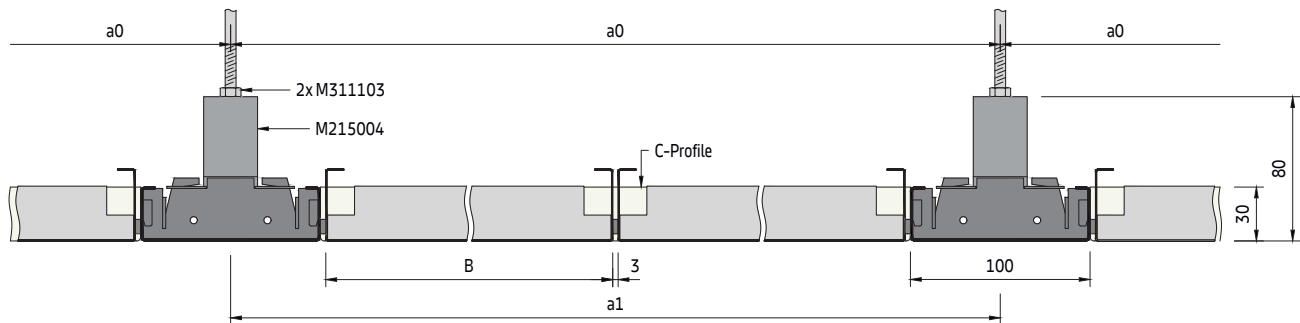

Panels supplied as standard with a 3mm gasket on one long and both short sides to improve the visual appearance. Optionally panels can be supplied without a gasket (except SWING panel option).

Grid components

Standard components

- M215004 Crossing box 100 x 100 mm RAL 9010
- - C-Profile L x 100 mm RAL 9010
- M300118 Hanger for C-Profile 100 mm
- M300144 Wall anchor for C-Profile 100 mm
- M311103 Hexagonal nut M6
- M311105 Washer
- M311303 Hexagonal bolt M6 x 16 mm

Optional components

- M300026 J-Bar
- M311034 Extraction tool (Swing function)
- M311103 Washer
- M311148 Holder for J-Bar
- M311191 Self-drilling screw 3.5 x 9.5 mm
- M311303 Hexagonal bolt M6 x 16 mm
- M311307 Pop-Rivet TAPD 44 BS
- M900000 Black gasket 8x3 mm (spare roll)

Crossing box 100 x 100 mm

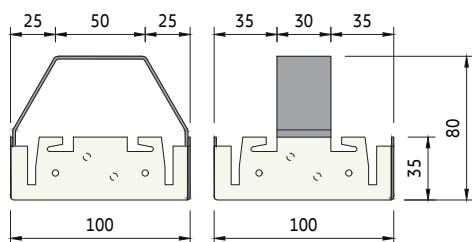

C-Profile 100 mm

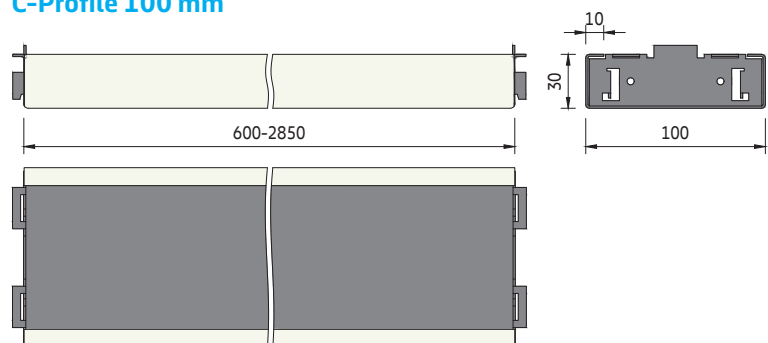

The layout of the ceiling does not necessarily have to be square. The distance (a1) and (a2) can deviate from each other. This also results in different distances for (a0).

The same applies to the crossing box. This is usually square, but can also be supplied rectangular on request.

Typical grid layout

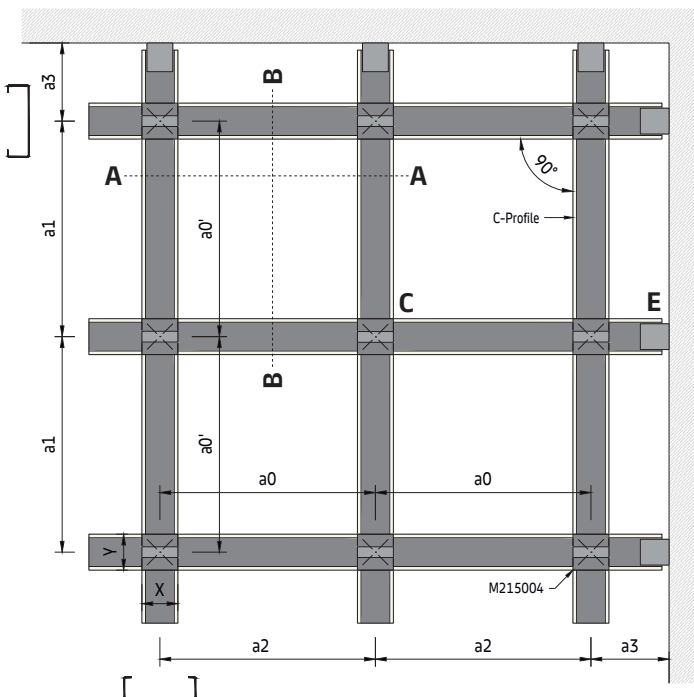

Parameters

- a0 Distance between crossing box suspension points = max. 1900 mm (if a1 or a2 is larger than a0 max., then the C-Profile will require additional suspension)
- a1 Distance between C-Profile 100 mm
- a2 Distance between C-Profile 100 mm
- a3 Distance from wall (if the distance is larger than 600 mm, then the C-Profile will require additional suspension)
- A Panel length = min. 600 / max. 2850 mm
- B Panel width = min. 247 / max. 1350 mm
- X Crossing box length = standard 100 mm, min. 70 / max. 300 mm
- Y Crossing Box width = standard 100 mm, min. 70 / max. 300 mm

Crossing box & C-Profile options

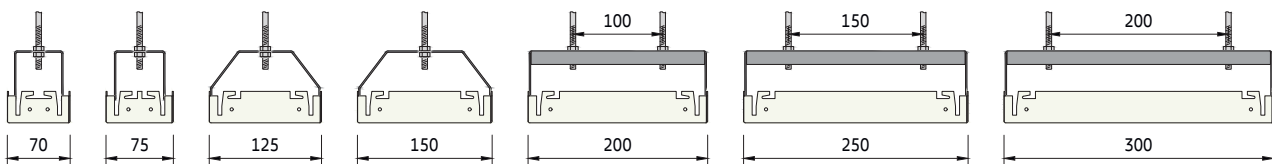

Crossing boxes and C-Profiles can be supplied in different sizes on request. For widths greater than 150 mm, two threaded rods are required for suspension.

Crossing boxes with cut-outs, hexagonal and octagonal shapes, etc. are available on request.

Detail C

Crossing box installation

1

Set the threaded rods in the corners of the modules. Level the height of the ceiling using the top hexagonal nut. Insert the crossing box from below and secure using the second (lower) hexagonal nut. Align the crossing boxes.

2

Connect the crossing boxes with the C-Profiles. To do this, use the two tabs at the ends of the C-Profiles and hook them in.

3

With pliers, the two tabs on the crossing box can be bent inwards by 30°. This secures the connection. Repeat the process to fix all C-Profiles. If the load is asymmetrical, the C-Profiles should also be fixed with two pop-rivets.

Detail D

Additional hanger installation

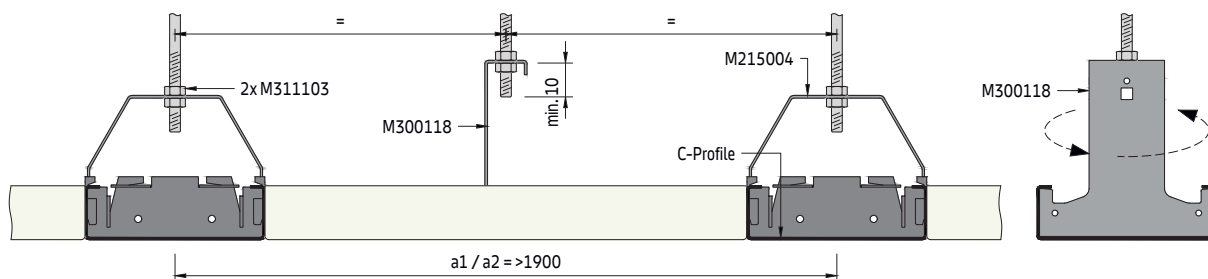

If the distance between the suspension points (a_0) is greater than 1900 mm, an additional hanger for C-Profile must be used. The same also applies to an additional load of +4 kg/m². A hanger is twisted in and suspended with a threaded rod. The hanger is ideally placed in the middle of the C Profile.

Detail E

Wall anchor installation

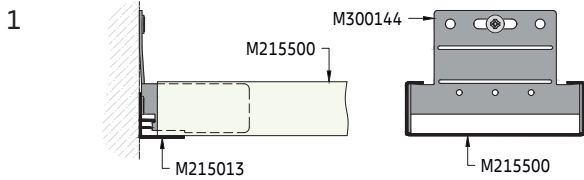

The wall anchor prevents the C-Profile from swinging and thus contributes to the safe installation of the substructure. The wall anchor has no load-bearing function and is only attached to one end of the room to secure the C-Profile.

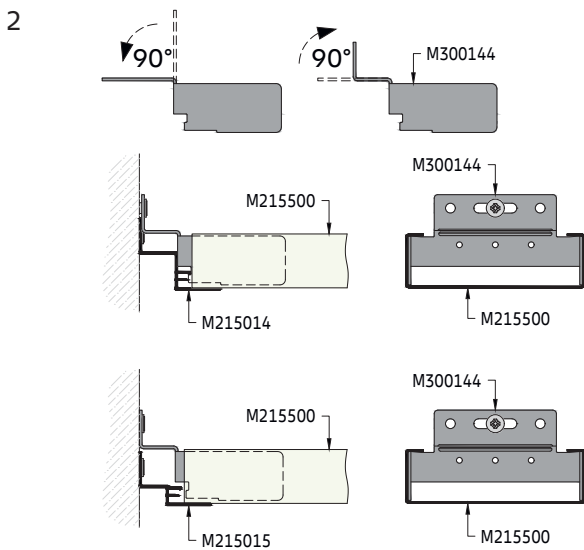

When using a shadowline perimeter trim, the upper part must first be bent 90° down and then 90° up again, so that a step is created.

Detail F

Perimeter detail max. 600 mm

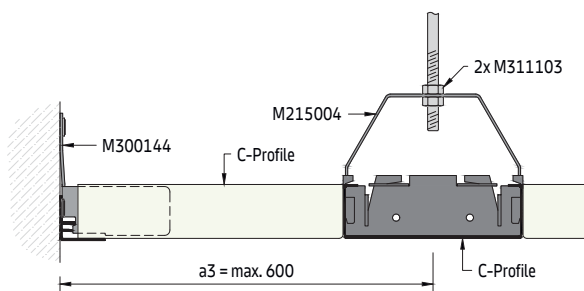

Perimeter detail 601 - 1900 mm with additional hanger

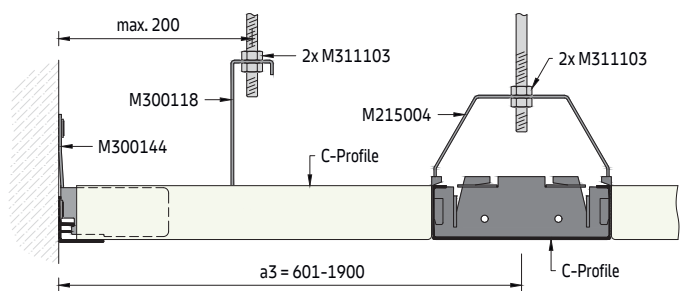

Perimeter detail 1901 - 2900 mm with additional hangers

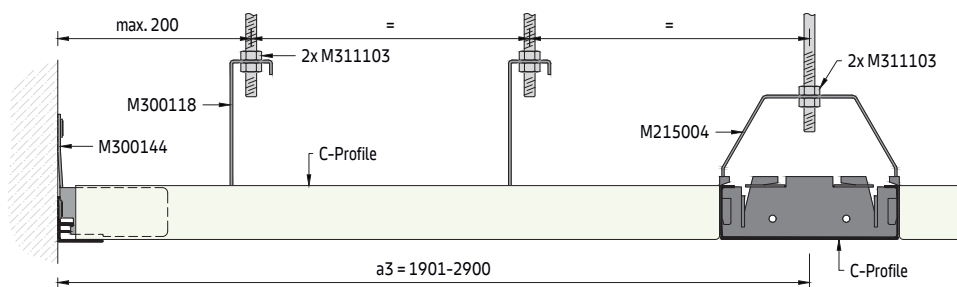

If the distance to the first suspension point (a_3) is greater than 600 mm, then the C-Profile will require additional suspension. If the distance is greater than 1900 mm, two hangers are needed.

Detail G

Panel insertion

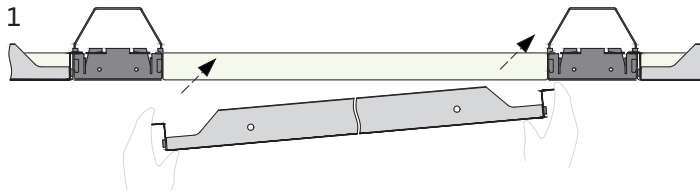

Insert the panel at a slight angle, above the C-Profile.

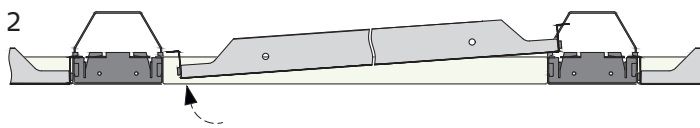

Lift up the opposite end of the panel above the opposite C-Profile.

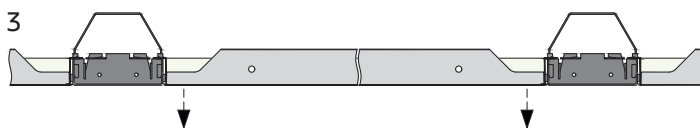

Rest the panel on the C-Profiles.

Panel extraction



With a closed ceiling, any panel can be removed as long as there are no obstacles such as service integrations, etc.

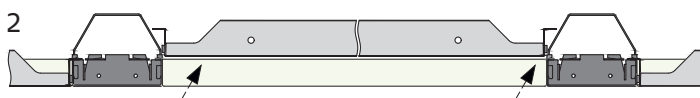

Lift the panel above the C-Profile.

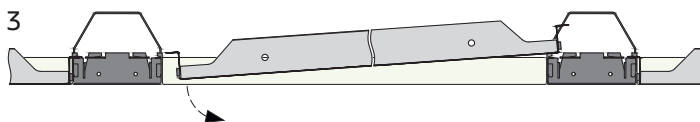

Lower the opposite side.

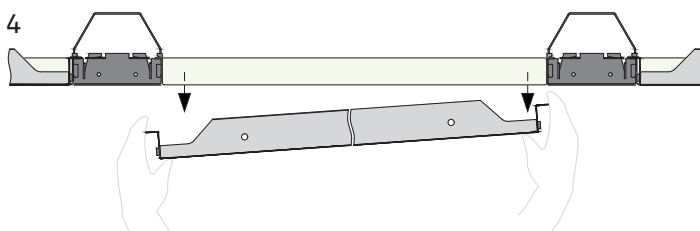

Remove it downwards and store the panel in a safe place so that it cannot be damaged.

Detail H

METAL K-H 400 EASY

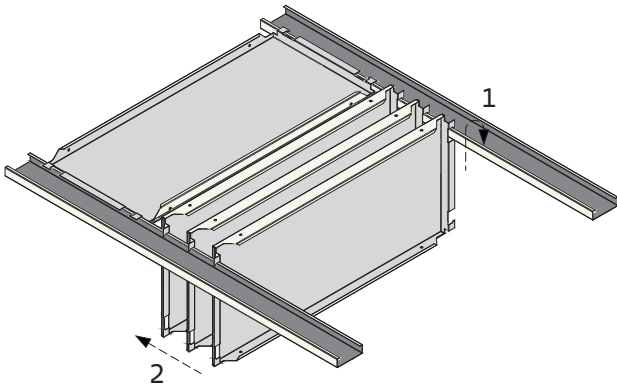

- 1 Extract the panel as shown under Detail L and hang it back vertically on the C-profile. The panels hinge-down from the long side.
Move the panel aside to allow access to the plenum. Up to three adjacent panels can be suspended at once. Do not exceed this number, otherwise the weight would be too high on the C-Profile.
- 2

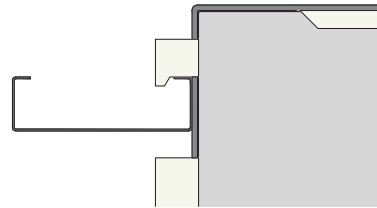

METAL K-H 400 SWING

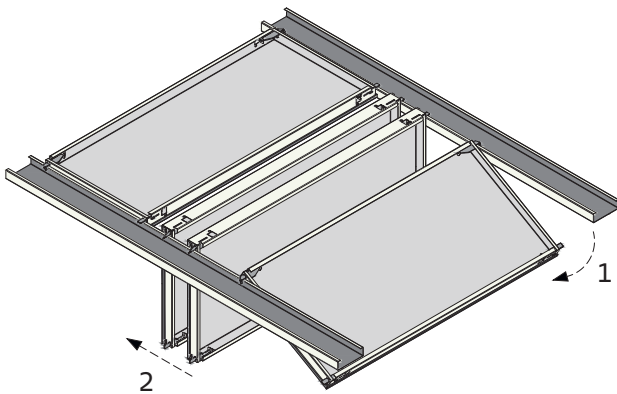

- 1 Use the extraction tool to release the brackets on the panel. Swing the panel down carefully. Insert the extraction tool carefully to avoid damaging the gasket. The panels swing-down from the long side.
- 2 Move the panel aside to allow access to the plenum. Up to three adjacent panels can be suspended at once. Do not exceed this number, otherwise the weight would be too high on the C-Profile.

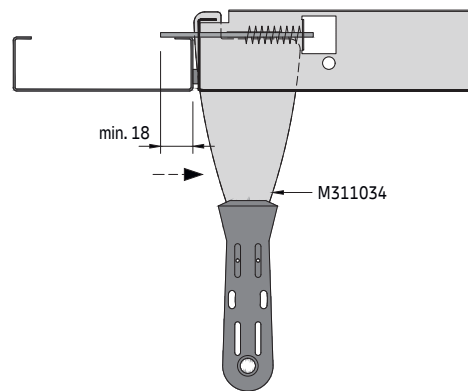

METAL K-H 400 Swing panels only available with 3 mm gasket on the long and both short sides. Be careful that the brackets do not scratch the C-Profile.

METAL K-H 400 HOOK

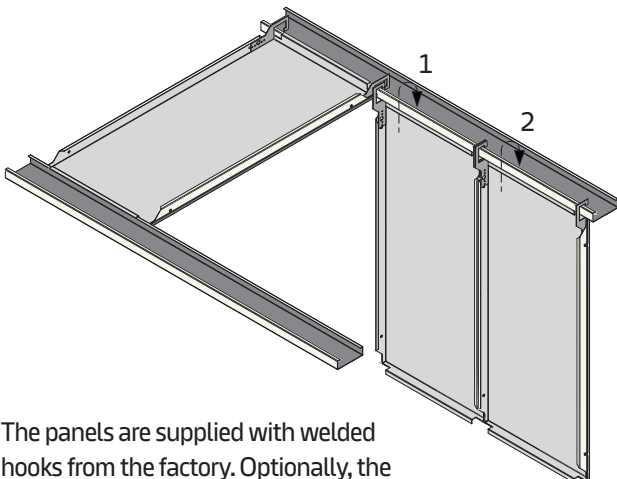

- 1 Extract the panel as shown under Detail L and hang it back vertically on the C-profile. The panels hinge-down from the short side.
- 2 Up to three adjacent panels can be suspended at once. Do not exceed this number, otherwise the weight would be too high on the C-Profile.

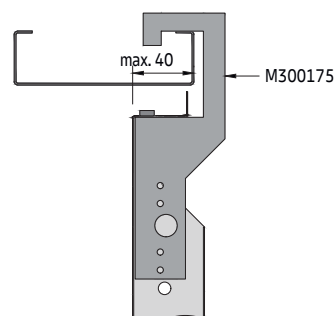

The panels are supplied with welded hooks from the factory. Optionally, the hooks can be fixed on site with two rivets.

Detail I

J-Bar holder installation for 2x2 or 3x3 panel layout

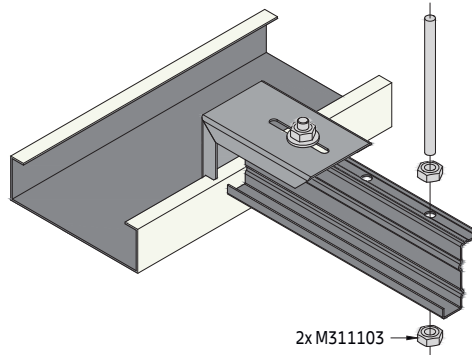
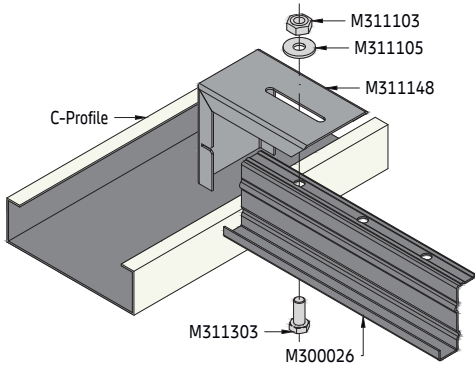

Layouts with 2x2 / 3x3 panels are possible. One / two J-Bars are additionally required for this. These are fixed to the C-Profile with a J-Bar holder. In addition, the J-Bar must also be suspended in the middle with a threaded rod from a length of 1500 mm.

2x2 panel layout

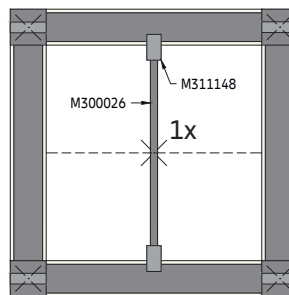

3x3 panel layout

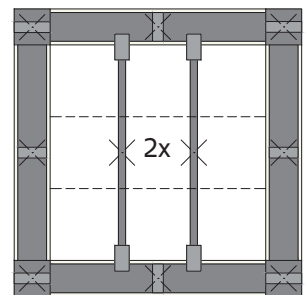

Optional 2x2 panel layout

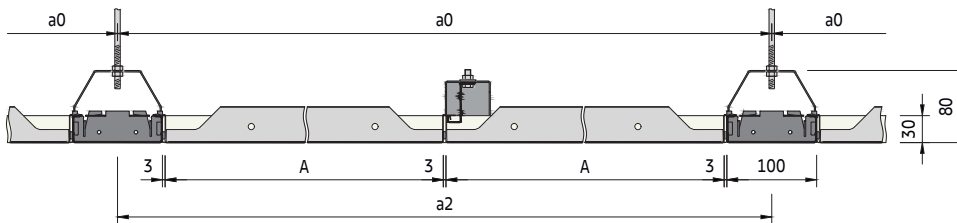

Optional 3x3 panel layout

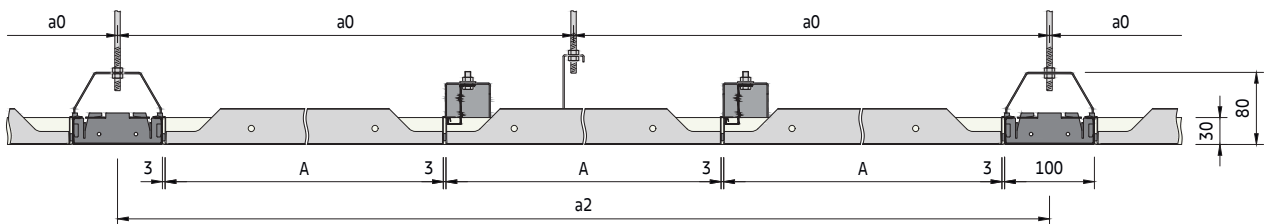

Material required per m² (no waste included)System without additional load [pcs/m²]

Components		a2 [mm]	1200	1600	1800	2000	2200	2400	2600	2950
M215004	Crossing box 100 x 100 mm RAL 9010		0.70	0.39	0.31	0.25	0.21	0.17	0.15	0.12
-	C-Profile L x 100 mm RAL 9010		1.67	1.25	1.11	1.00	0.91	0.83	0.77	0.68
M300118	Hanger for C-Profile 100 mm		-	-	-	0.50	0.42	0.35	0.30	0.23
M300144	Wall anchor for C-Profile 100 mm		0.28	0.24	0.20	0.20	1.60	1.60	1.20	0.12
M311099	Threaded rod M6 x 1000 mm		0.70	0.40	0.31	0.75	0.63	0.53	0.45	0.35
M311103	Hexagonal nut M6		1.40	0.80	0.62	1.50	1.26	1.06	0.90	0.70
M311105	Washer		0.70	0.40	0.31	0.75	0.63	0.53	0.45	0.35
M311303	Hexagonal bolt M6 x 16 mm		0.70	0.40	0.33	0.75	0.63	0.53	0.45	0.35

The shown quantities are theoretical and based on an ideal layout, without considering the actual room layout. The ideal layout is based on a calculation of 10 x 10 m (100 m²). This calculation does not allow any damage, spare nor wastage. The final quantities and type of suspension have to be checked before ordering. Soffit and wall fixings by others.

Not including perimeter trims, optional components and extraction tools.



METAL K-H 400
Club Internacional del Libro, Madrid, Spain
© Francisco Urrutia





Concealed Grid Ceilings

METAL Q-Clip / METAL Q-Clip F / METAL R-Clip

U-Profile primary grid + DP12 A-Bar secondary grid
Concealed grid solution for indoor applications

General information

- Concealed clip-in grid system for small and medium rooms (METAL Q-Clip, METAL Q-Clip F), medium and large rooms (METAL R-Clip)
- For perpendicular installation on U-Profile primary grid
- DP12 A-Bar made of galvanised steel
- Typical ceiling weight 5.5 - 6.5 kg/m² (METAL Q-Clip, METAL Q-Clip F), 7.5 - 9.0 kg/m² (METAL R-Clip) (indicative value for unperforated panels / tiles, without additional load)
- Panels / tiles are easily installed and fully demountable
- Optional swing-down function WINDOW
- Optional security clips available
- Exterior application see separate document

Isometric view

Select the suspension option E1 - E4.
Perimeter solutions on separate datasheet.

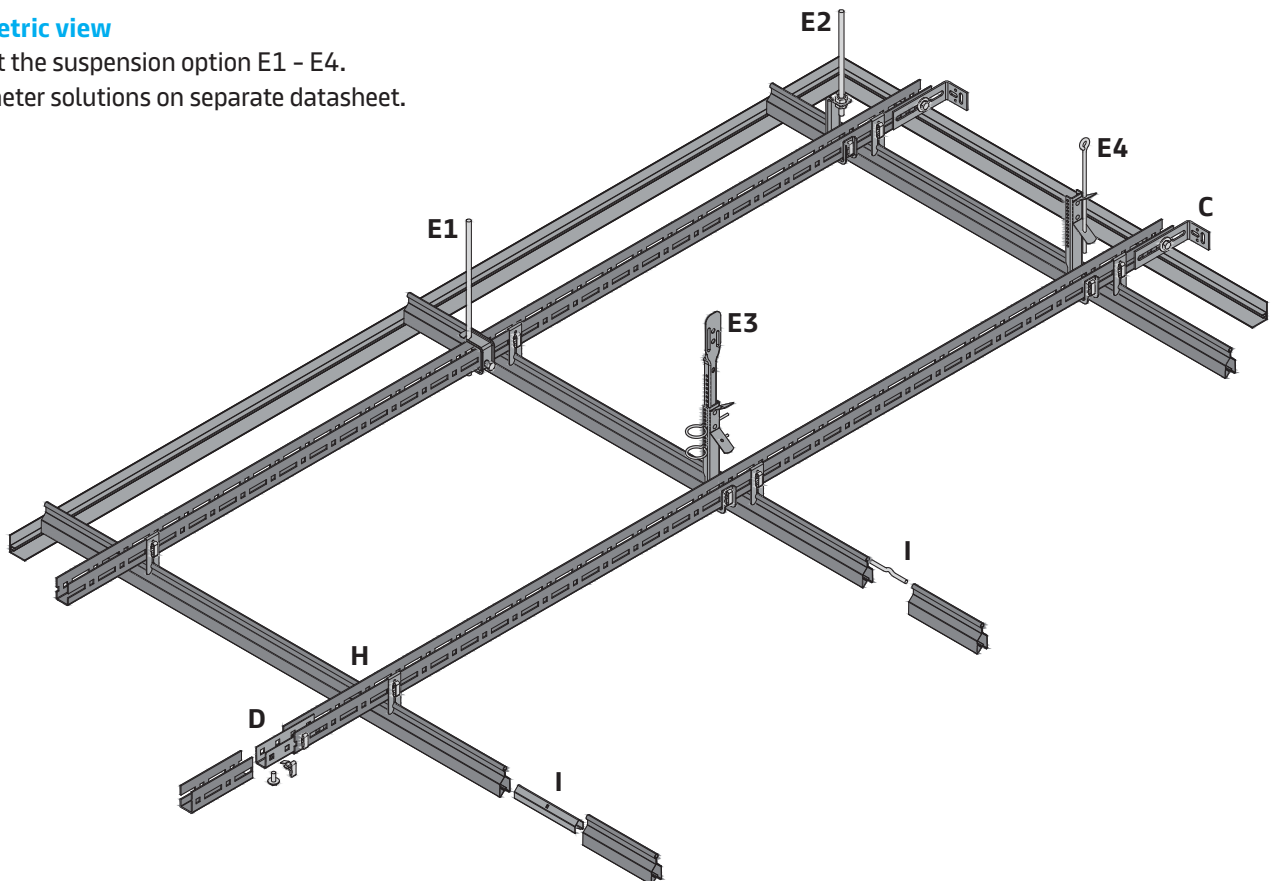

Standard & Vario Design layout options

Standard (METAL Q-Clip / METAL Q-Clip F)

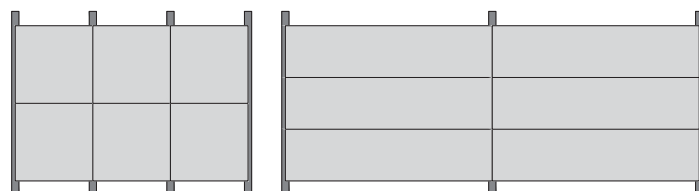

Vario Design (METAL R-Clip)

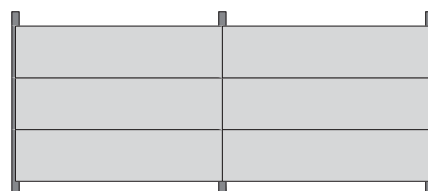

METAL Q-Clip / METAL Q-Clip F / METAL R-Clip
D02.100

Section F (METAL Q-Clip, METAL Q-Clip F)

Example with suspension option E1

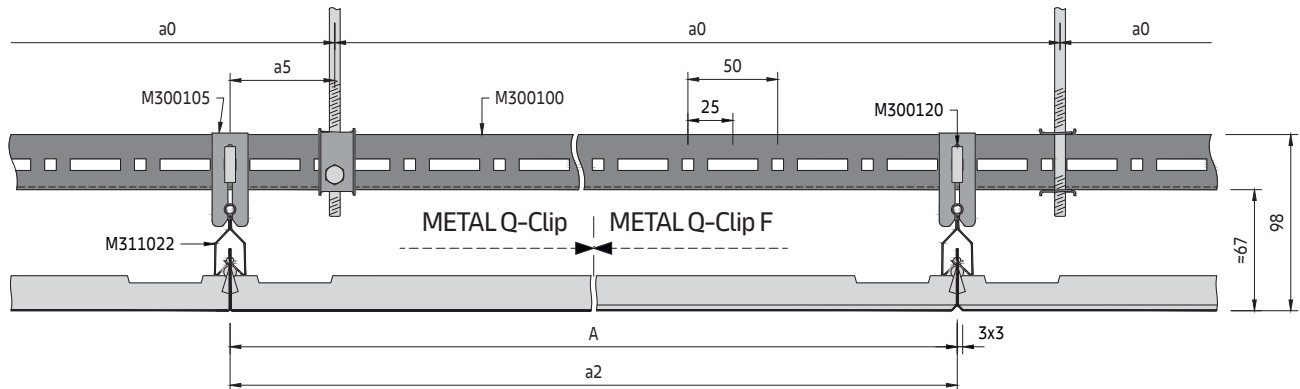

Section F (METAL R-Clip)

Example with suspension option E1

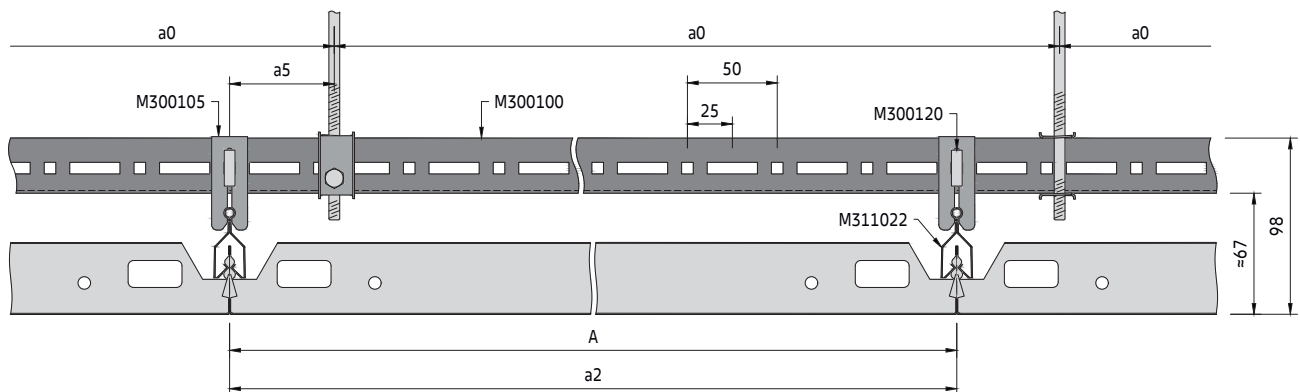

Secondary grid components

Standard components

- M311022 DP12 A-Bar
- M300138 Connection pin for DP12 A-Bar
- M300105 Hanger for DP12 A-Bar
- M300120 Plug-in clip for U-Profile

Optional components

- M300106 Security clip
- M300157 Security clip for WINDOW function
- M311023 Splice connector for DP12 A-Bar
- M311027 Swing-down clip for WINDOW function
- M311028 Extraction tool
- M311191 Self-drilling screw 3.5 x 9.5 mm

See U-Profile primary grid for primary grid components

DP12 A-Bar secondary grid

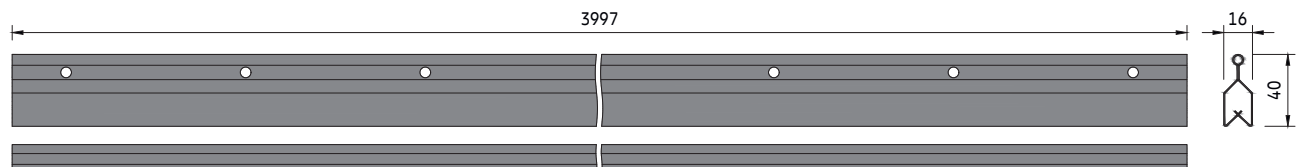

METAL Q-Clip / METAL Q-Clip F / METAL R-Clip
 D02.100

Section G (METAL Q-Clip, METAL Q-Clip F)

Example with suspension option E1

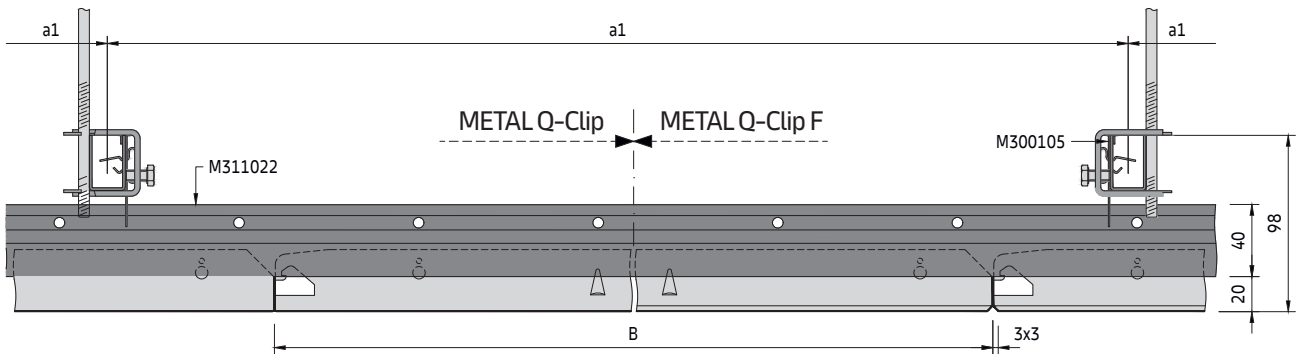

Section G (METAL R-Clip)

Example with suspension option E1

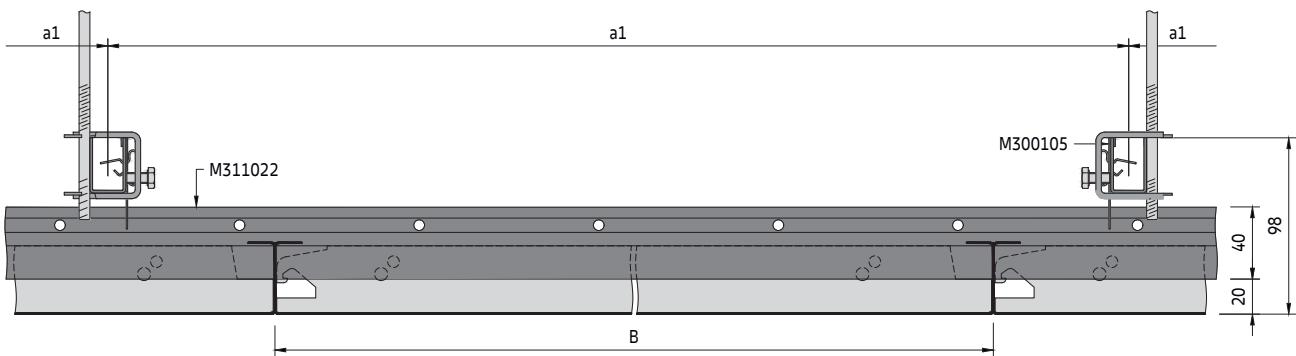

METAL Q-Clip and METAL R-Clip modules are compatible and can be combined with each other.

METAL Q-Clip / METAL Q-Clip F / METAL R-Clip
D02.100

Spacing

a2 [mm]	System without additional load		System with additional load +4 kg/m ²		System with additional load +6 kg/m ²	
	a0 [mm]	a1 [mm]	a0 [mm]	a1 [mm]	a0 [mm]	a1 [mm]
600	1200	1900	1200	1700	1200	1450
625	1250	1850	1250	1550	1250	1350
650	1300	1800	1300	1450	1300	1250
700	1400	1750	1400	1250	700	1500
750	1500	1650	750	1550	750	1450
800	1600	1450	800	1500	800	1400
850	850	1600	850	1450	850	1400
900	900	1550	900	1400	900	1350
950	950	1550	950	1400	950	1300
1000	1000	1500	1000	1350	1000	1300
1050	1050	1450	1050	1300	1050	1250
1100	1100	1450	1100	1300	1100	1250
1150	1150	1400	1150	1250	1150	1200
1200	1200	1350	1200	1250	1200	1150
1250	1250	1350	1250	1200	1250	1150
1300	1300	1300	1300	1200	1300	1150
1350	1350	1300	1350	1150	1350	1100
1400	1400	1300	1400	1150	1400	1100
1450	1450	1250	1450	1100	1450	1000
1500	1500	1250	1500	1100	1500	950
1550	1550	1200	1550	1050	1550	900
1600	1600	1200	1600	1000	1600	850
1650	1650	1200	1650	900	1650	800
1700	1700	1150	1700	850	1700	750
1750	1750	1150	1750	800	1750	650
1800	1800	1100	1800	700	1800	600
1850	1850	1000	1850	650	1850	550
1900	1900	950	1900	600	1900	500
1950	975	1100	975	950	975	950
2000	1000	1050	1000	950	1000	900
2050	1025	1050	1025	950	1025	900
2100	1050	1050	1050	950	1050	900
2150	1075	1050	1075	900	1075	900
2200	1100	1000	1100	900	1100	900
2250	1125	1000	1125	900	1125	850
2300	1150	1000	1150	900	1150	850
2350	1175	1000	1175	900	1175	850
2400	1200	1000	1200	850	1200	850
2450	1225	950	1225	850	-	-
2500	1250	950	1250	850	-	-

Parameters

- a0 Distance between U-Profile suspension points = max. 1900 mm
- a1 Max. distance between U-Profiles
- a2 Distance between DP12 A-Bars = tile/panel length
- a3 Distance from wall = max. 200 mm
- a4 Distance from wall = max. tile/panel length
- a5 Distance from U-Profile suspension point to hanger = max. 100 mm
- M Module size = tile/panel length / tile/panel width

METAL Q-Clip

M 600 x 600, 625 x 625 mm

METAL Q-Clip F

M 600 x 600, 625 x 625, 1200 x 300, 1200 x 600, 1800 x 400 mm

METAL R-Clip

A Panel length = min. 600 / max. 2500 mm

B Panel width = min. 250 / max. 600 mm

Typical grid layout

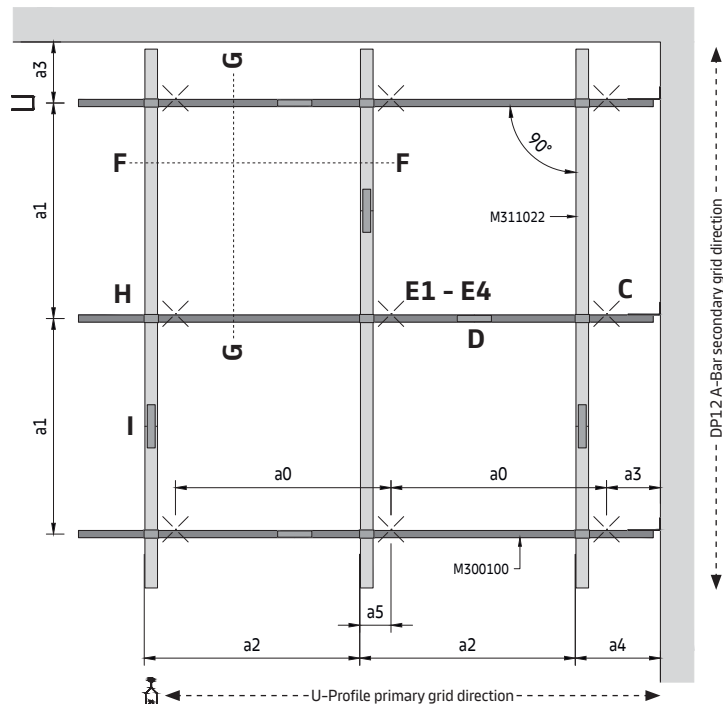

To determine suspension layout

The module length (M) of the requested ceiling is equal to the distance between the DP12 A-Bar centres (a2). On the appropriate spacing table, read down the column headed (a2) to the required module length then read across to determine the suspension point spacing (a0) and U-Profile spacing (a1). The shown values are maximum allowed distances and can be reduced but not exceeded.

METAL Q-Clip / METAL Q-Clip F / METAL R-Clip
D02.100

Detail H

Hanger installation

1

M300105
M311022

The hanger for DP12 A-Bar is made of spring steel and is therefore elastic. It is twisted on the DP12 A-Bar from above. Then it can be slid to the correct position.

2

M300100

Hang the DP12 A-Bar with the hangers under the U-Profile.

3

Optional fixing

Vertical Horizontal

a2 a2

M300120

Fix hanger with plug-in clips at the specified module spacing (inserted vertically or horizontally). If the panel size does not fit with the modulation of the U-Profile (25 mm increments), the plug-in clip needs to be inserted into a long hole. The hanger position can alternatively be fixed by using a pop-rivet or self-drilling screw.

4

The DP12 A-Bar is now locked in position. Due to the round head of the DP12 A-Bar, it can swing. This is important because it allows any tolerances to be compensated. Otherwise the tiles/panels could no longer be inserted after a certain point.

Detail I

Splice connection

1

M311022 M300138

≈13

Insert the connection pin at the ends of the DP12 A-Bars and connect them. There is a gap between the DP12 A-Bars. The DP12 A-Bars must be aligned so that the joint is not in the same place as the pips on the tiles/panels.

2

M311022 M311023

≈1

Optionally, the splice connector for DP12 A-Bar can be used. This is inserted at the ends of the DP12 A-Bars and an almost seamless connection is created.

METAL Q-Clip / METAL Q-Clip F / METAL R-Clip
D02.100

Detail J

Tile/panel insertion (example with METAL Q-Clip)

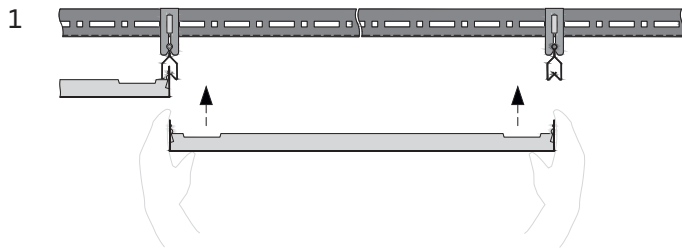

Take the tile/panel and carefully insert it into the DP12 A-Bars from below. All tiles/panels feature a double row of pips. The upper pip is inserted into the DP12 A-Bar, the lower one serves as a stop. Care is required when installing tiles. Always press along the edges with the pips and never on the transverse sides, otherwise the tile may be damaged. The tiles/panels should always be laid in such a way that the WINDOW hooks point in the same direction.

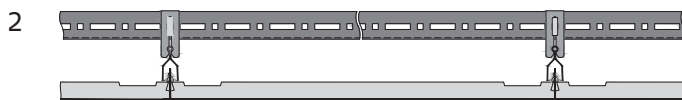

The tiles/panels are correctly inserted when all four corners are flush with the neighbouring tiles/panels. The tiles/panels are designed to match the DP12 A-Bar. If third party profiles are used there is a high probability the tiles will not be correctly inserted.

METAL Q-Clip

METAL R-Clip

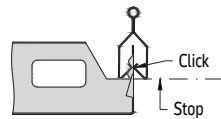
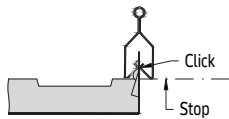

Tile/panel extraction (example with METAL Q-Clip / METAL R-Clip)

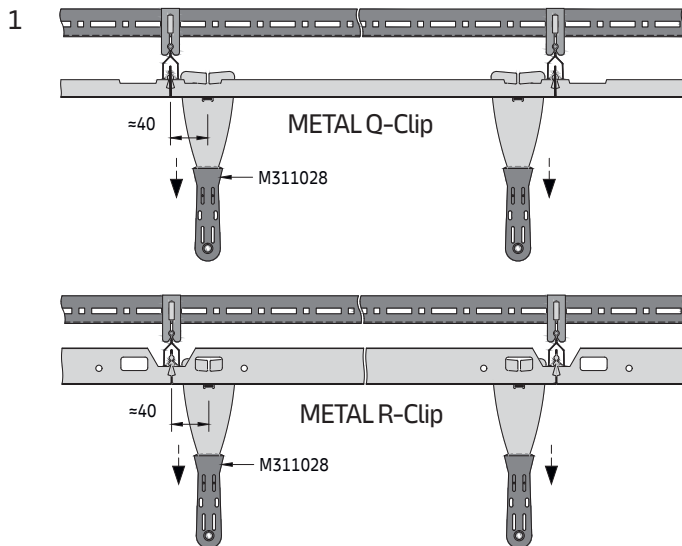

The tiles/panels are designed in such a way that the extraction tool can only be inserted in the designated places so that it clicks into place. There is an indentation on the tiles for this purpose, and a rectangular cut-out on the panels. It is therefore important that the appropriate extraction tool is used. This prevents damage to the tiles/panels. Insert on one side first and pull down with a gentle tug, followed by the opposite side.

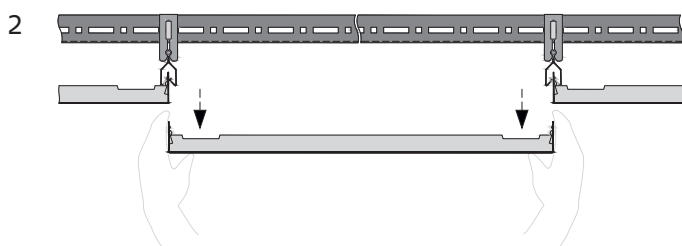

Remove it downwards and store the tile/panel in a safe place so that it cannot be damaged.

METAL Q-Clip / METAL Q-Clip F / METAL R-Clip
D02.100

Detail K

Optional security clip

The security clip serves to secure the tiles/panels and prevents them from being removed.

Tile/panel locking

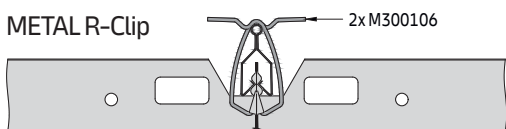
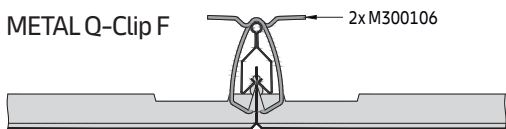
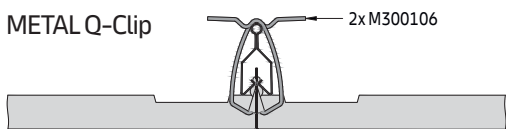

The tiles/panels have, on the sides where the pins are, an embossing where the security clip can be fixed. First hook the security clip into the tile/panel and then slip the upper end over the DP12 A-Bar. Two security clips are required per tile/panel.

Either individual tiles/panels or the entire ceiling can be secured. The tiles/panels are inserted and secured immediately. The last tile/panel cannot be locked.

METAL Q-Clip, METAL Q-Clip F, METAL Q-Clip F (rectangular shapes), METAL R-Clip

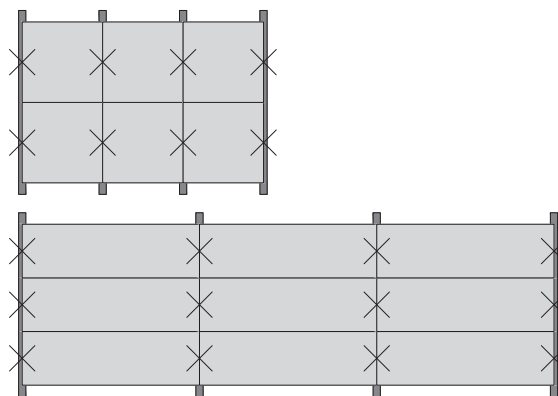

Material required per m² (no waste included)
System without additional load [pcs/m²]

Components		a2 [mm]	500	600	625	1200	1500	1800	2000	2500
M300100	U-Profile		0.17	0.14	0.15	0.20	0.21	0.24	0.26	0.28
M300105	Hanger for DP12 A-Bar		1.30	0.88	0.87	0.62	0.54	0.51	0.48	0.43
M300119	Splice connector for U-Profile		0.18	0.15	0.15	0.20	0.22	0.25	0.26	0.29
M300120	Plug-in clip for U-Profile		1.66	1.28	1.17	1.02	0.98	1.01	1.00	1.01
M300138	Connection pin for DP12 A-Bar		0.50	0.42	0.40	0.21	0.17	0.14	0.13	0.10
M300140	Wall anchor		0.07	0.06	0.06	0.08	0.09	0.10	0.10	0.11
M311022	DP12 A-Bar		0.50	0.42	0.40	0.21	0.17	0.14	0.13	1.00
M311103	Hexagonal nut M6		0.10	0.10	0.10	0.10	0.10	0.10	0.10	0.20
M311105	Washer		0.10	0.10	0.10	0.10	0.10	0.10	0.10	0.20
M311303	Hexagonal bolt M6 x 16 mm		0.10	0.10	0.10	0.10	0.10	0.10	0.10	0.20
Various	Suspension points (E1 - E4)		0.44	0.44	0.44	0.62	0.54	0.51	0.96	0.85

The shown quantities are theoretical and based on an ideal layout, without considering the actual room layout. The ideal layout is based on a calculation of 10 x 10 m (100 m²). This calculation does not allow any damage, spare nor wastage. The final quantities and type of suspension have to be checked before ordering. Soffit and wall fixings by others. Not including perimeter trims, optional security clips, extraction tools and swing-down brackets.

METAL Q-Clip / METAL Q-Clip F / METAL R-Clip
D02.100

Detail L

Optional WINDOW swing-down function

The tiles/panels are provided with two WINDOW hooks, which are used to swing-down. Unlike the standard installation, the tiles/panels are installed alternately (hook to hook) and not in the same direction.

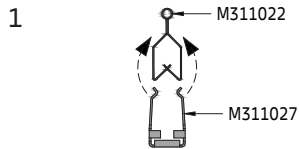

Where the hooks are positioned, the swing-down clip for WINDOW function is placed on the DP12 A-Bar. This is hooked over the DP12 A-Bar from below and fixed with a security clip.

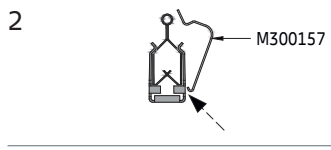

The security clip is first inserted from below and slipped over the DP12 A-Bar. The tiles/panels should be inserted at an angle of $\approx 30^\circ$ so that the hook is positioned over the swing-down clip for WINDOW.

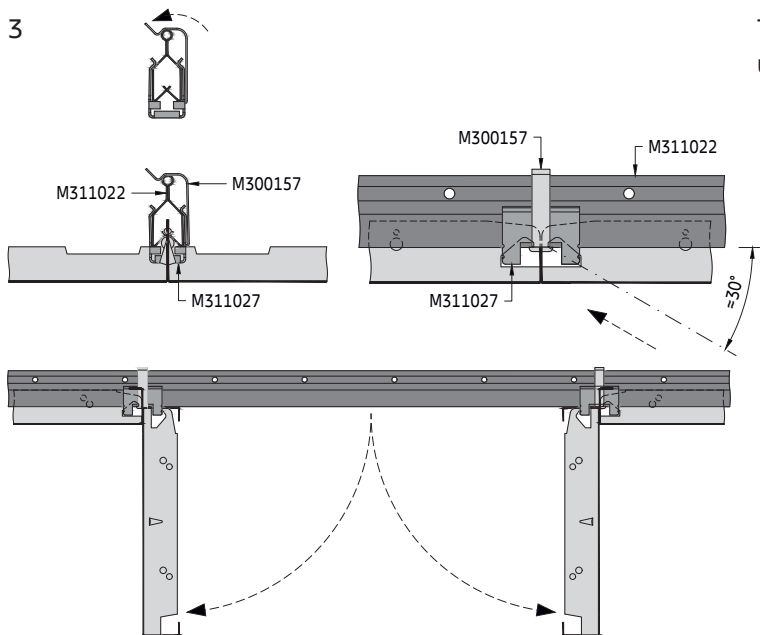

The ceiling is opened with the extraction tool, as shown under detail J.

METAL R-Clip

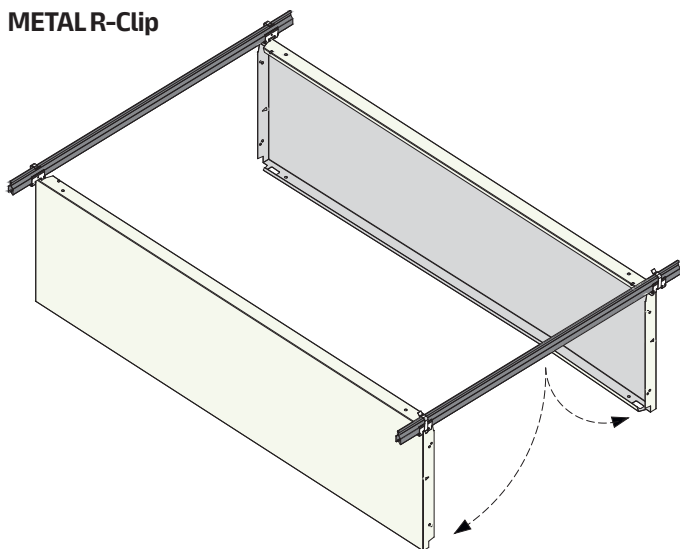

METAL Q-Clip F

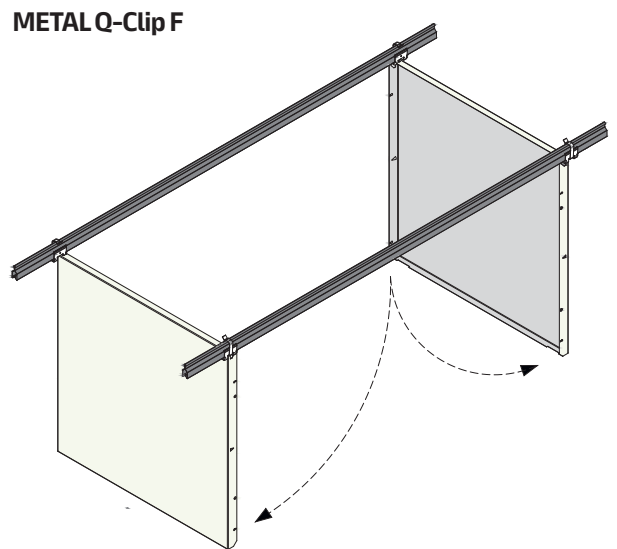

METAL Q-Clip / METAL Q-Clip F / METAL R-Clip

DP12 A-Bar primary grid + DP12 A-Bar secondary grid
Concealed grid solution for indoor applications

General information

- Concealed clip-in grid system for small and medium rooms (METAL Q-Clip, METAL Q-Clip F), medium and large rooms (METAL R-Clip)
- For perpendicular installation on DP12 A-Bar primary grid
- DP12 A-Bar made of galvanised steel
- Typical ceiling weight 5.5 - 6.5 kg/m² (METAL Q-Clip, METAL Q-Clip F), 7.5 - 9.0 kg/m² (METAL R-Clip) (indicative value for unperforated panels / tiles, without additional load)
- Panels / tiles are easily installed and fully demountable
- Optional swing-down function WINDOW
- Optional security clips available

Isometric view

Select the suspension option D1 - D2.
Perimeter solutions on separate datasheet.

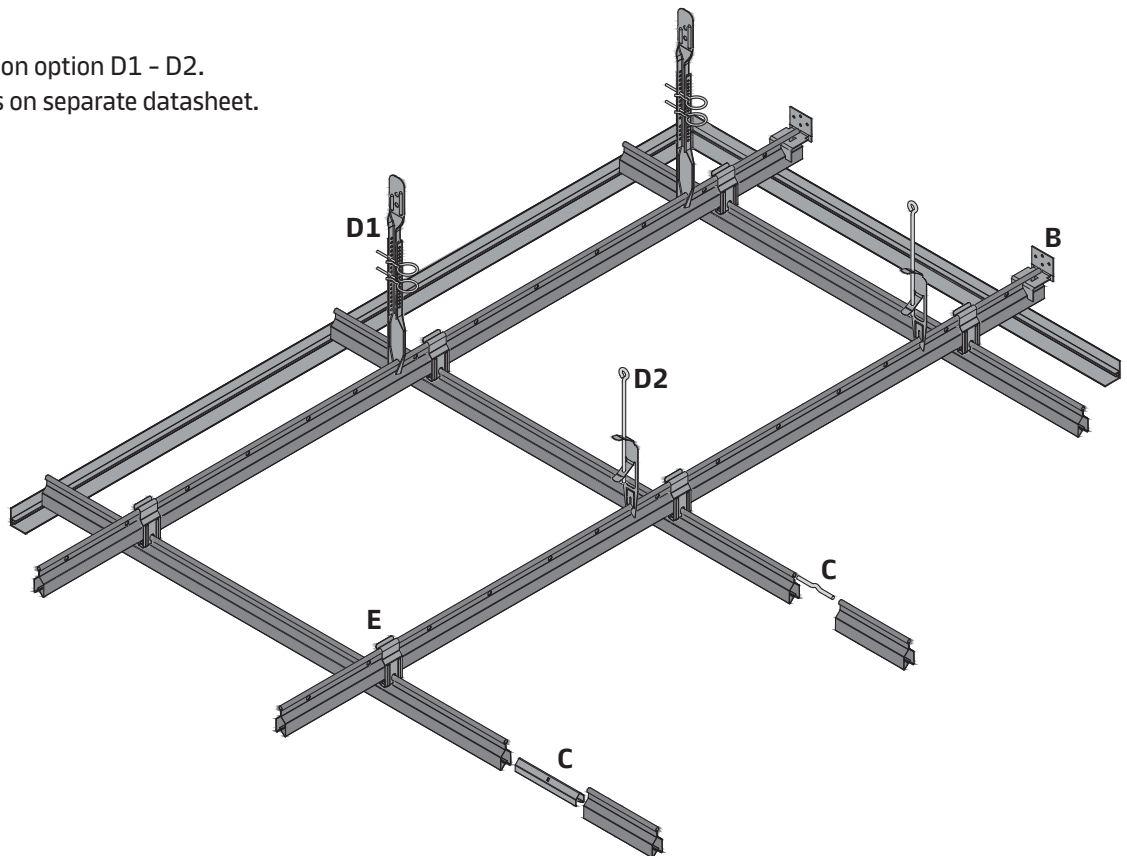

Standard & Vario Design layout options

Standard (METAL Q-Clip / METAL Q-Clip F)

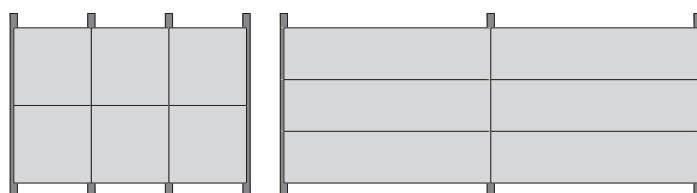

Vario Design (METAL R-Clip)

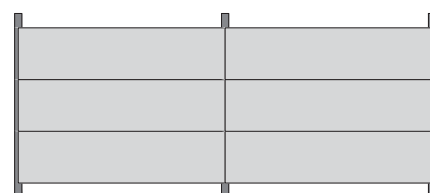

METAL Q-Clip / METAL Q-Clip F / METAL R-Clip
D02.100.1

Section F (METAL Q-Clip, METAL Q-Clip F)

Example with suspension option D2

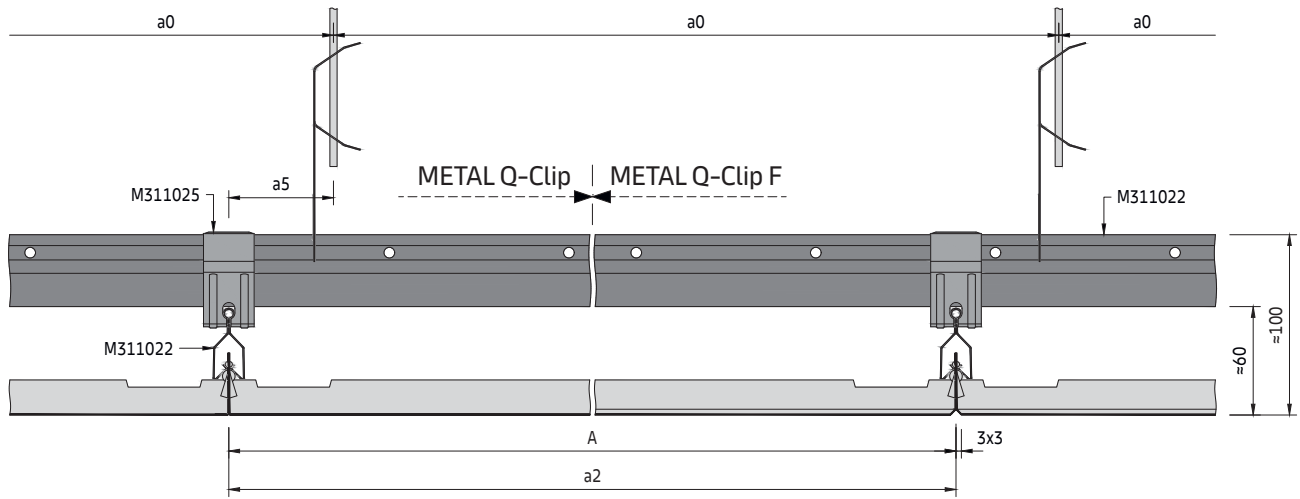

Section F (METAL R-Clip)

Example with suspension option D2

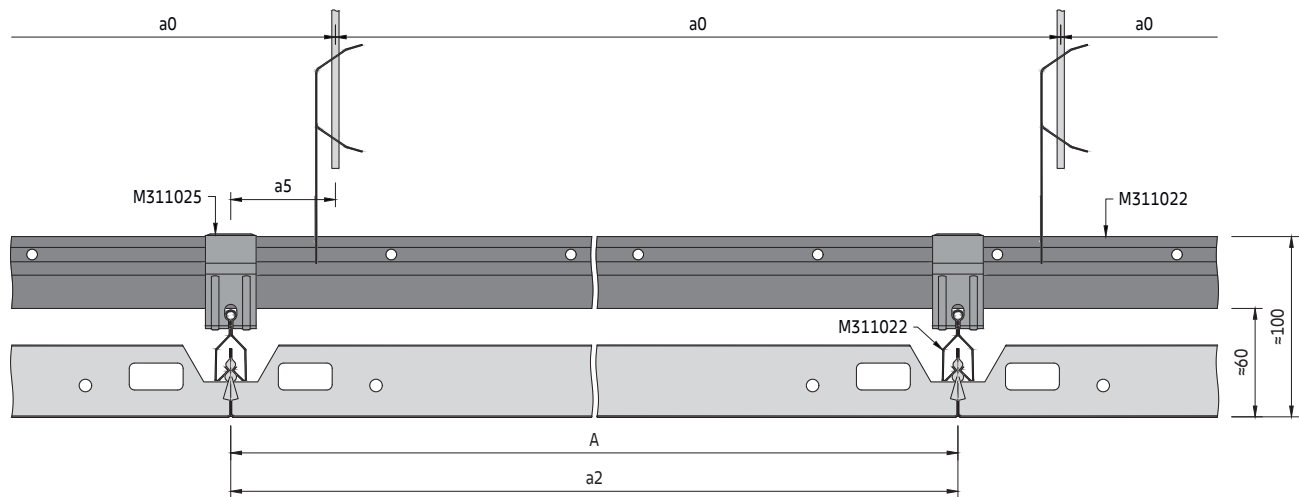

Secondary grid components

Standard components

- M311022 DP12 A-Bar
- M300138 Connection pin for DP12 A-Bar
- M311025 Cross connector for DP12 A-Bar

Optional components

- M300106 Security clip
- M300157 Security clip for WINDOW function
- M311023 Splice connector for DP12 A-Bar
- M311027 Swing-down clip for WINDOW function
- M311028 Extraction tool

See DP12 A-Bar primary grid for primary grid components

DP12 A-Bar secondary grid

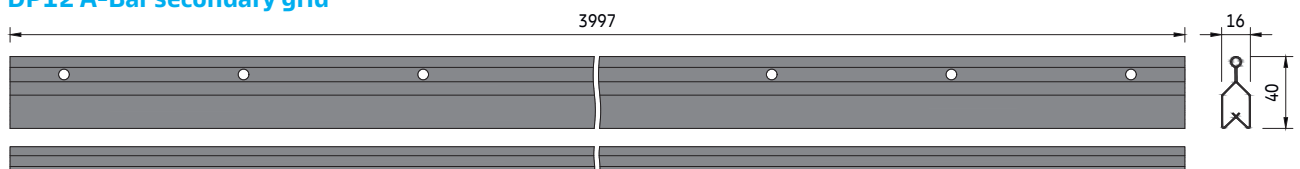

METAL Q-Clip / METAL Q-Clip F / METAL R-Clip
D02.100.1

Section G (METAL Q-Clip, METAL Q-Clip F)
Example with suspension option D2

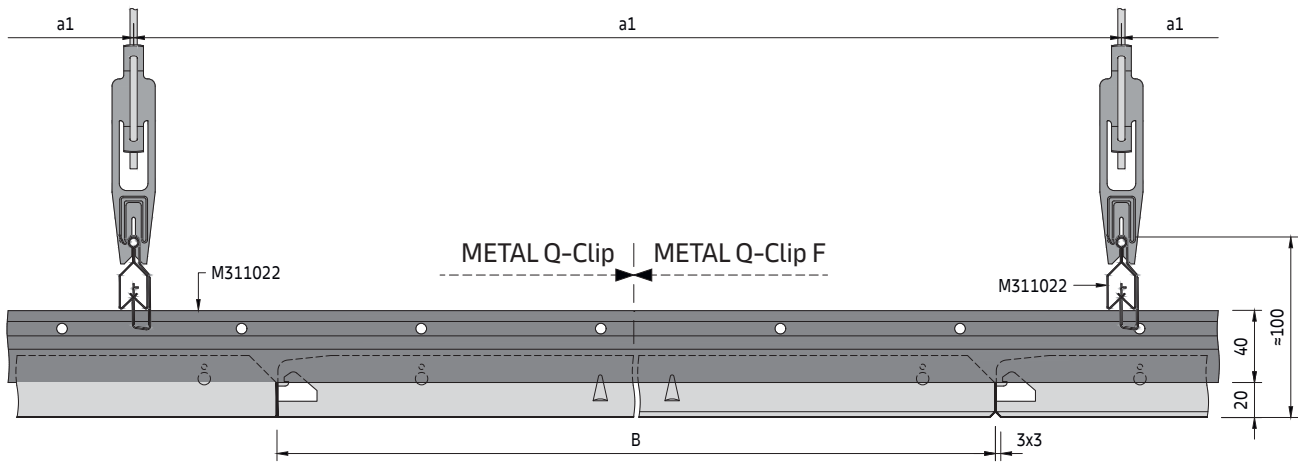

Section G (METAL R-Clip)
Example with suspension option D2

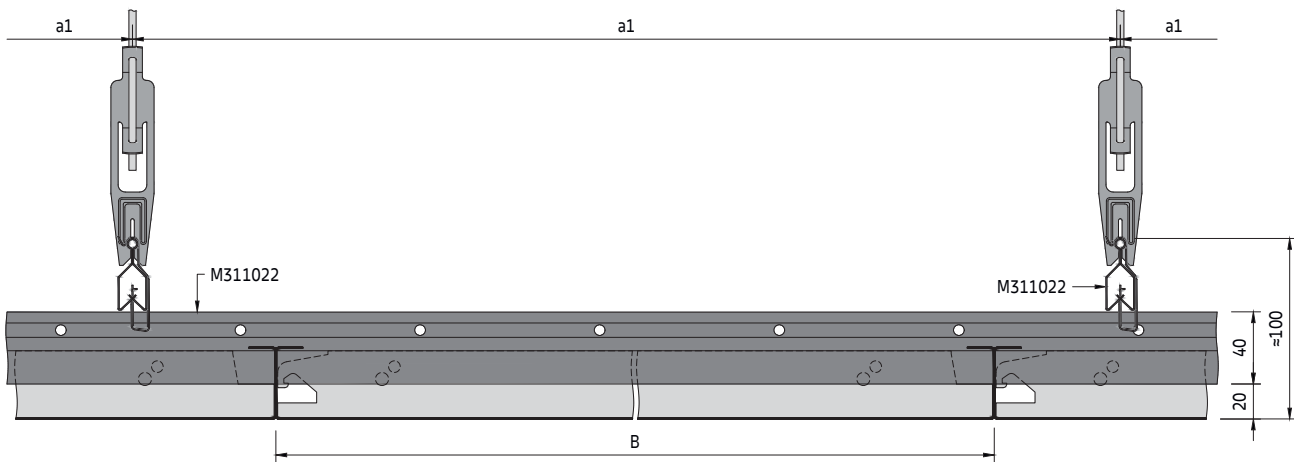

METAL Q-Clip and METAL R-Clip modules are compatible and can be combined with each other.

METAL Q-Clip / METAL Q-Clip F / METAL R-Clip
D02.100.1

Spacing

a2 [mm]	System without additional load		System with additional load +4 kg/m ²		System with additional load +6 kg/m ²	
	a0 [mm]	a1 [mm]	a0 [mm]	a1 [mm]	a0 [mm]	a1 [mm]
500	1500	1200	1500	800	1500	650
600	1200	1900	1200	1300	1200	1050
625	1250	1700	1250	1100	1250	950
650	1300	1700	1300	1100	1300	900
700	1400	1450	1400	950	1400	750
750	1500	1300	750	1550	750	1500
800	1600	1100	800	1600	800	1450
850	850	1800	850	1550	850	1450
900	900	1750	900	1550	900	1400
950	950	1750	950	1500	950	1400
1000	1000	1700	1000	1500	1000	1350
1050	1050	1700	1050	1450	1050	1350
1100	1100	1650	1100	1450	1100	1250
1150	1150	1650	1150	1450	1150	1150
1200	1200	1600	1200	1400	1200	1050
1250	1250	1600	1250	1250	1250	950
1300	1300	1600	1300	1150	1300	900
1350	1350	1550	1350	1100	1350	800
1400	1400	1550	1400	1000	1400	750
1450	1450	1450	1450	900	1450	700
1500	1500	1350	1500	850	1500	650
1550	1550	1250	1550	800	1550	600
1600	1600	1200	1600	750	800	1150
1650	1650	1100	1650	700	825	1150
1700	1700	1050	1700	650	850	1150
1750	1750	950	1750	600	875	1150
1800	1800	850	1800	550	900	1150
1850	1850	800	1850	500	925	1100
1900	1900	700	1900	450	950	1100
1950	975	1400	975	1200	975	1100
2000	1000	1400	1000	1200	1000	1100
2050	1025	1400	1025	1200	1025	1100
2100	1050	1350	1050	1200	1050	1050
2150	1075	1350	1075	1150	1075	1050
2200	1100	1350	1100	1150	1100	1050
2250	1125	1350	1125	1150	1125	1050
2300	1150	1350	1150	1150	1150	1050
2350	1175	1300	1175	1150	1175	1050
2400	1200	1300	1200	1150	1200	1000
2450	1225	1300	1225	1100	-	-
2500	1250	1300	1250	1100	-	-

Parameters

- a0 Distance between DP12 A-Bar suspension points = max. 1900 mm
- a1 Max. distance between DP12 A-Bars
- a2 Distance between DP12 A-Bars = tile / panel length
- a3 Distance from wall = max. 200 mm
- a4 Distance from wall = max. tile / panel length
- a5 Distance from DP12 A-Bar suspension point to hanger = max. 100 mm
- M Module size = tile / panel length / tile / panel width

METAL Q-Clip

M 600 x 600, 625 x 625 mm

METAL Q-Clip F

M 600 x 600, 625 x 625, 1200 x 300, 1200 x 600, 1800 x 400 mm

METAL R-Clip

A Panel length = min. 600 / max. 2500 mm

B Panel width = min. 250 / max. 600 mm

Typical grid layout

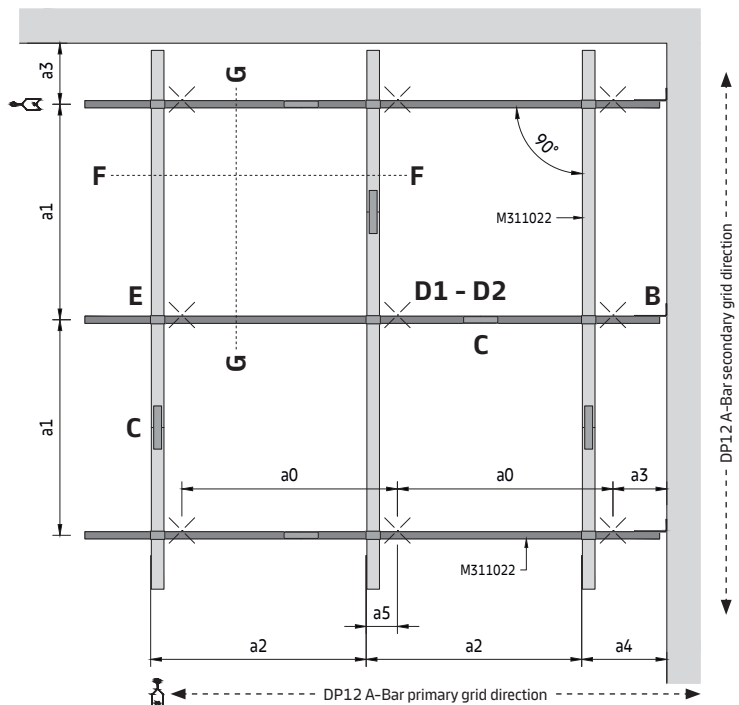

To determine suspension layout

The module length (M) of the requested ceiling is equal to the distance between the DP12 A-Bar centres (a2). On the appropriate spacing table, read down the column headed (a2) to the required module length then read across to determine the suspension point spacing (a0) and direct hanger spacing (a1). The shown values are maximum allowed distances and can be reduced but not exceeded.

METAL Q-Clip / METAL Q-Clip F / METAL R-Clip
D02.100.1

Detail E

Cross Connector installation

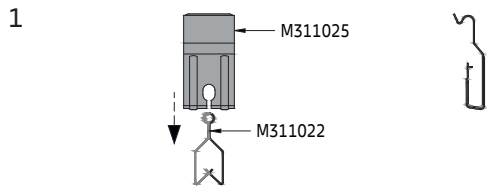

The cross connector is inserted from the end of the DP12 A-Bar secondary grid. Then it can be slid to the correct position.

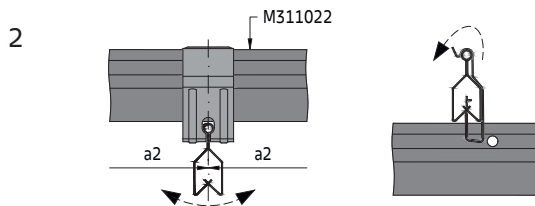

The cross connector for DP12 A-Bar is made of spring steel and is therefore elastic. It is hooked on the DP12 A-Bar primary grid. The DP12 A-Bar secondary grid is now locked in position. Due to the round head of the DP12 A-Bar, it can swing. This is important because it allows any tolerances to be compensated. Otherwise the tiles / panels will no longer be inserted after a certain point.

Detail C

Splice connection

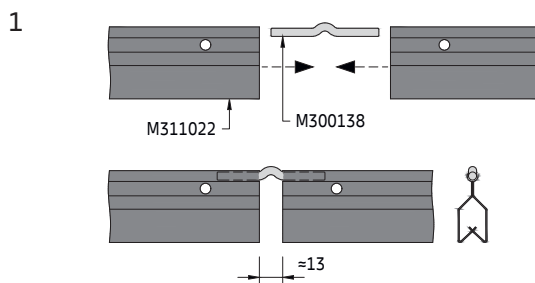

Insert the connection pin at the ends of the DP12 A-Bars and connect them. There is a gap between the DP12 A-Bars. The DP12 A-Bars must be aligned so that the joint is not in the same place as the pips on the tiles / panels.

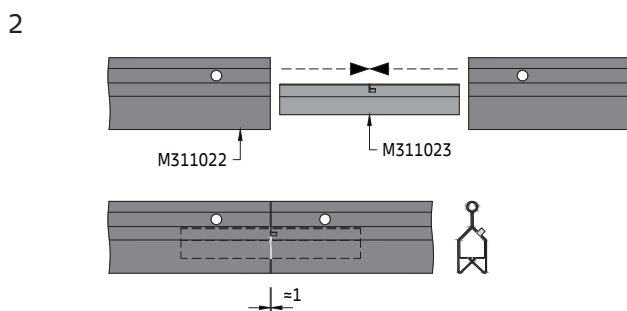

Optionally, the splice connector for DP12 A-Bar can be used. This is inserted at the ends of the DP12 A-Bars and an almost seamless connection is created.

METAL Q-Clip / METAL Q-Clip F / METAL R-Clip
D02.100.1

Detail I

Tile / panel insertion (example with METAL Q-Clip)

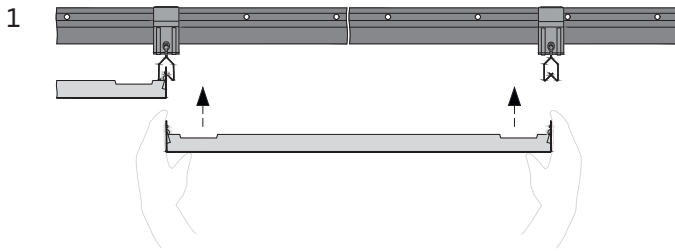

Take the tile / panel and carefully insert it into the DP12 A-Bars from below. All tiles / panels feature a double row of pips. The upper pip is inserted into the DP12 A-Bar, the lower one serves as a stop. Care is required when installing tiles. Always press along the edges with the pips and never on the transverse sides, otherwise the tile may be damaged. The tiles / panels should always be laid in such a way that the WINDOW hooks point in the same direction.

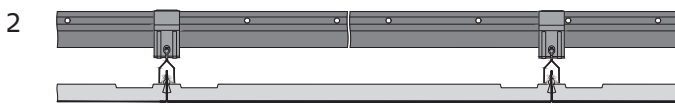

The tiles / panels are correctly inserted when all four corners are flush with the neighbouring tiles / panels. The tiles / panels are designed to match the DP12 A-Bar. If third party profiles are used there is a high probability the tiles will not be correctly inserted.

METAL Q-Clip

METAL R-Clip

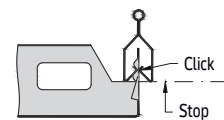
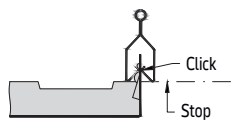

Tile / panel extraction (example with METAL Q-Clip / METAL R-Clip)

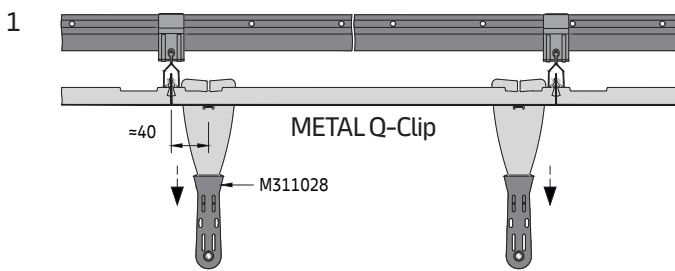

The tiles / panels are designed in such a way that the extraction tool can only be inserted in the designated places so that it clicks into place. There is an indentation on the tiles for this purpose, and a rectangular cut-out on the panels. It is therefore important that the appropriate extraction tool is used. This prevents damage to the tiles / panels. Insert on one side first and pull down with a gentle tug, followed by the opposite side.

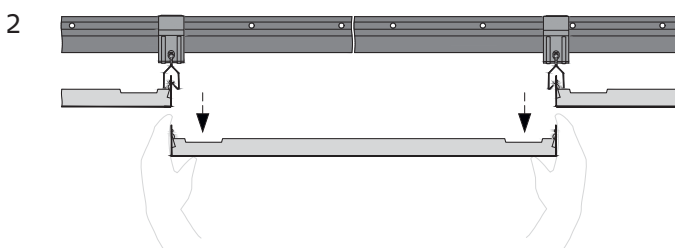
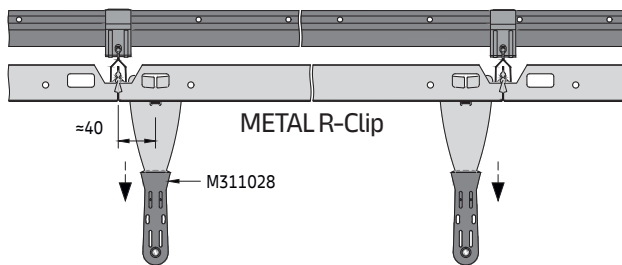

Remove it downwards and store the tile / panel in a safe place so that it cannot be damaged.

METAL Q-Clip / METAL Q-Clip F / METAL R-Clip
D02.100.1

Detail J

Optional security clip

The security clip serves to secure the tiles / panels and prevents them from being removed.

Tile / panel locking

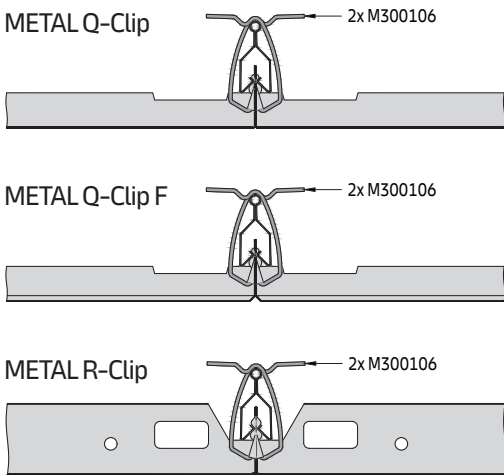

The tiles / panels have, on the sides where the pins are, an embossing where the security clip can be fixed. First hook the security clip into the tile / panel and then slip the upper end over the DP12 A-Bar. Two security clips are required per tile / panel.

Either individual tiles / panels or the entire ceiling can be secured. The tiles / panels are inserted and secured immediately. The last tile / panel cannot be locked.

METAL Q-Clip, METAL Q-Clip F

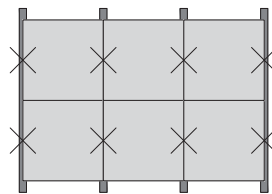

METAL Q-Clip F (rectangular shapes), METAL R-Clip

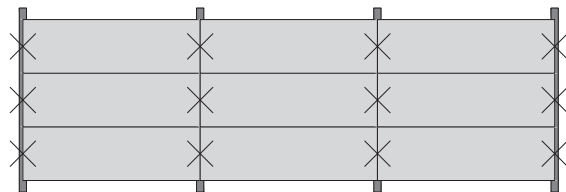

Material required per m² (no waste included)
System without additional load [pcs/m²]

Components		a2 [mm]	500	600	625	1200	1500	1800	2000	2500
M300138	Connection pin for DP12 A-Bar		0.67	0.55	0.54	0.37	0.36	0.44	0.31	0.30
M311022	DP12 A-Bar		0.66	0.55	0.54	0.37	0.35	0.43	0.31	0.29
M311024	Wall anchor for DP12 A-Bar		0.07	0.06	0.06	0.07	0.08	0.12	0.08	0.08
M311025	Cross connector for DP12 A-Bar		1.30	0.88	0.87	0.53	0.50	0.66	0.36	0.31
Various	Suspension points (D1 - D2)		1.77	1.83	1.72	1.22	0.94	0.97	1.22	0.94

The shown quantities are theoretical and based on an ideal layout, without considering the actual room layout. The ideal layout is based on a calculation of 10 x 10 m (100 m²). This calculation does not allow any damage, spare nor wastage. The final quantities and type of suspension have to be checked before ordering. Soffit and wall fixings by others. Not including perimeter trims, optional security clips, extraction tools and swing-down brackets.

METAL Q-Clip / METAL Q-Clip F / METAL R-Clip
D02.100.1

Detail K

Optional WINDOW swing-down function

The tiles / panels are provided with two WINDOW hooks, which are used to swing-down. Unlike the standard installation, the tiles / panels are installed alternately (hook to hook) and not in the same direction.

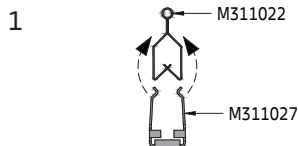

Where the hooks are positioned, the swing-down clip for WINDOW function is placed on the DP12 A-Bar. This is hooked over the DP12 A-Bar from below and fixed with a security clip.

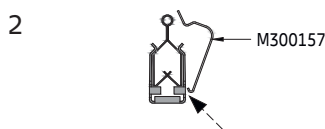

The security clip is first inserted from below and slipped over the DP12 A-Bar. The tiles / panels should be inserted at an angle of $\approx 30^\circ$ so that the hook is positioned over the swing-down clip for WINDOW.



The ceiling is opened with the extraction tool, as shown under detail J.

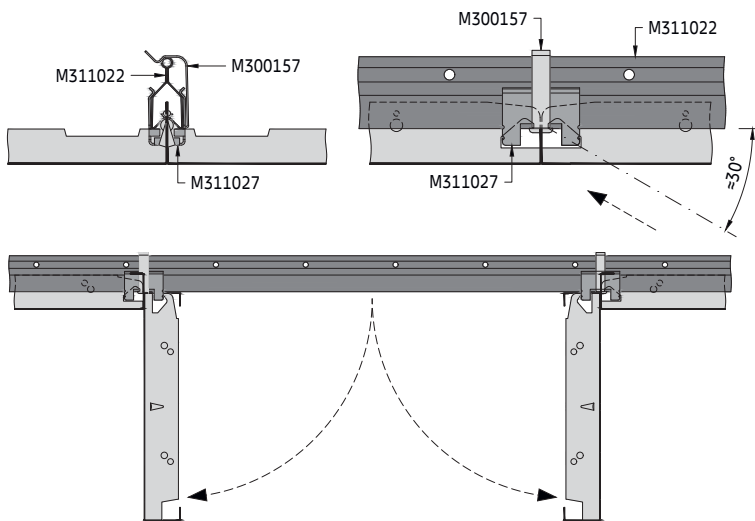

METAL R-Clip

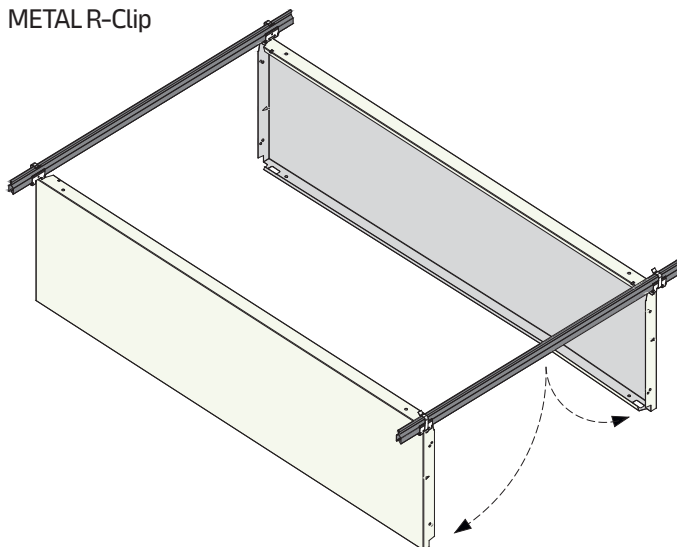

METAL Q-Clip F

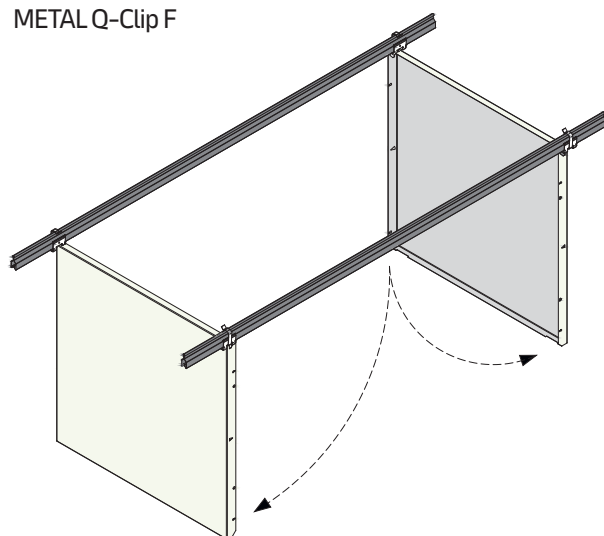

METAL Q-Clip / METAL Q-Clip F / METAL R-Clip

Direct suspended DP12 A-Bar
Concealed grid solution for indoor applications

General information

- Concealed clip-in grid system for small areas with low cavity
- DP12 A-Bar made of galvanised steel
- Typical ceiling weight 5.0 - 6.0 kg/m² (METAL Q-Clip, METAL Q-Clip F), 7.0 - 8.5 kg/m² (METAL R-Clip) (indicative value for unperforated panels / tiles, without additional load)
- Panels / tiles are easily installed and fully demountable
- Optional swing-down function WINDOW
- Optional security clips available

Isometric view

Select the suspension option D1 - D2.
Perimeter solutions on separate datasheet.

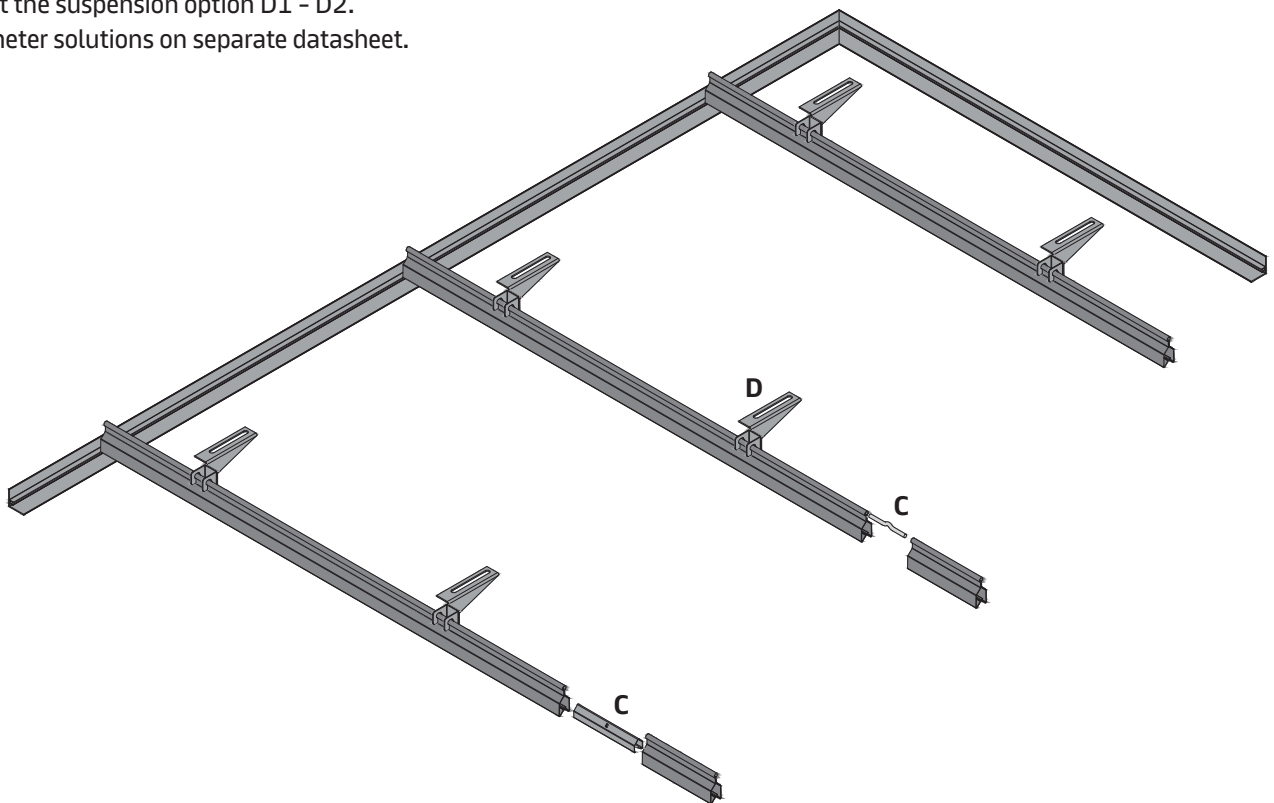

The use of a primary grid system is recommended, as this simplifies levelling and the alignment of the ceiling.

METAL Q-Clip / METAL Q-Clip F / METAL R-Clip
D02.100.2

Standard, Vario Design layout options

Standard

METAL Q-Clip / METAL Q-Clip F

Vario Design

METAL R-Clip

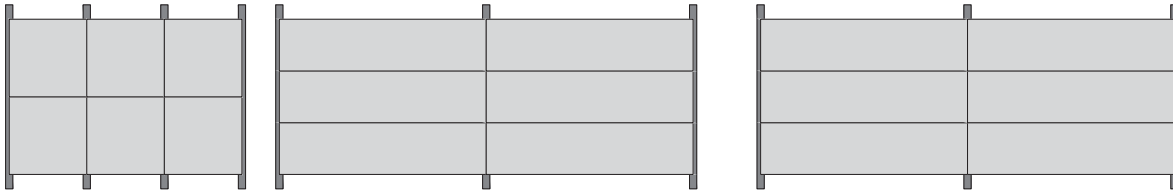

Section A (METAL Q-Clip, METAL Q-Clip F)

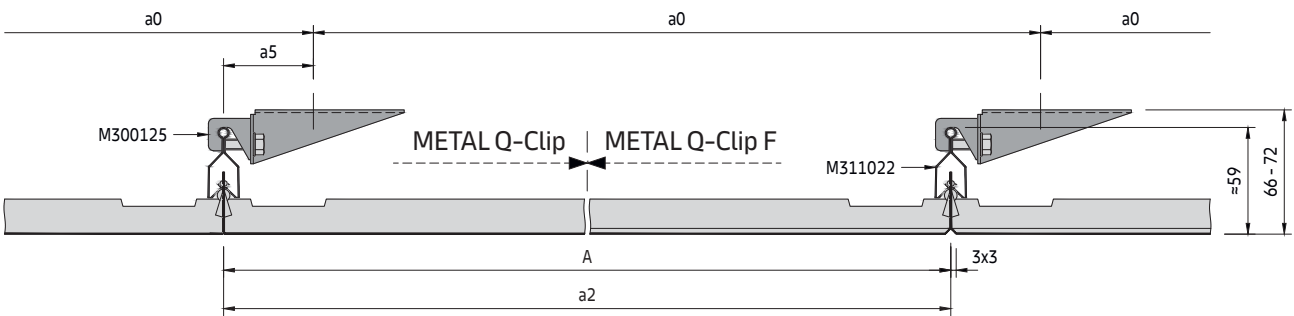

Section A (METAL R-Clip)

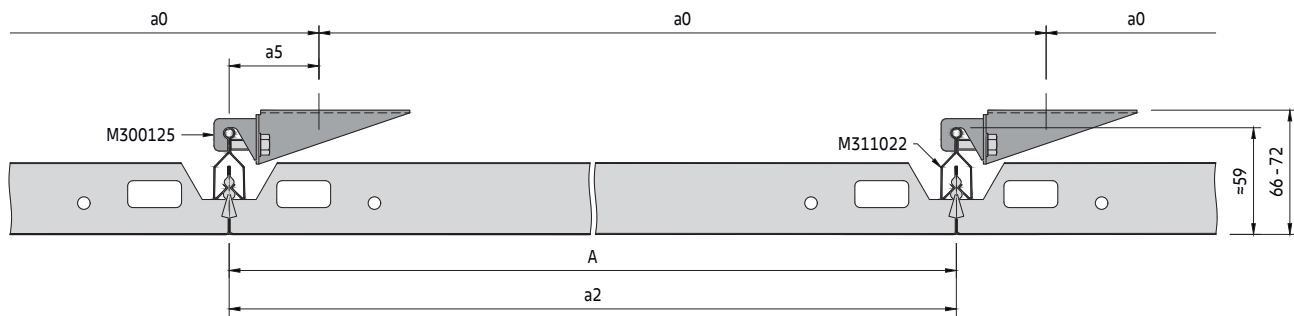

Secondary grid components

Standard components

- M311022 DP12 A-Bar
- M300138 Connection pin for DP12 A-Bar
- M300125 Direct hanger for DP12 A-Bar

Optional components

- M300106 Security clip
- M300157 Security clip for WINDOW function
- M311023 Splice connector for DP12 A-Bar
- M311027 Swing-down clip for WINDOW function
- M311028 Extraction tool

DP12 A-Bar

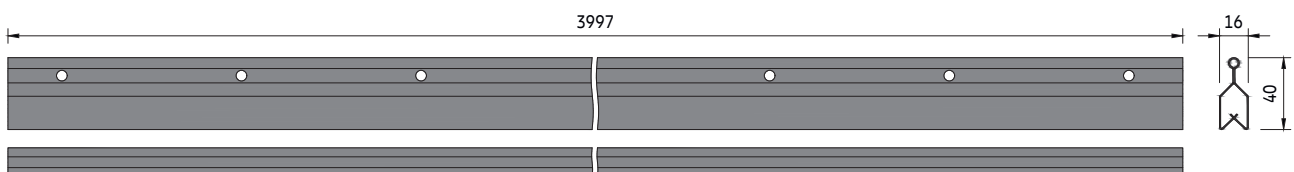

METAL Q-Clip / METAL Q-Clip F / METAL R-Clip
 D02.100.2

Section B (METAL Q-Clip, METAL Q-Clip F)

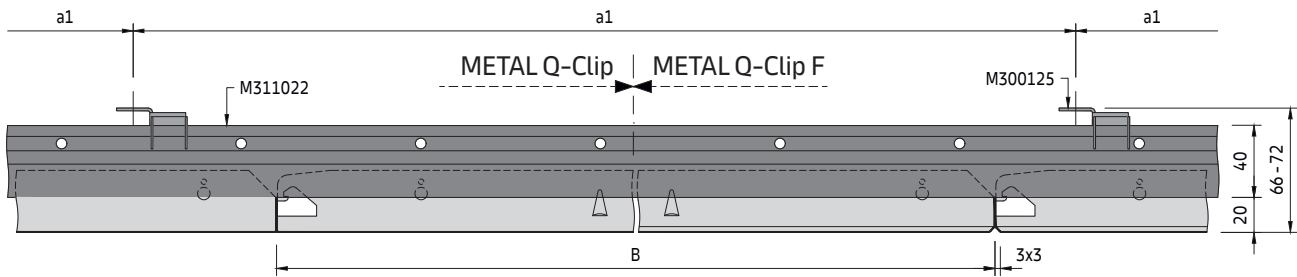

Section B (METAL R-Clip)

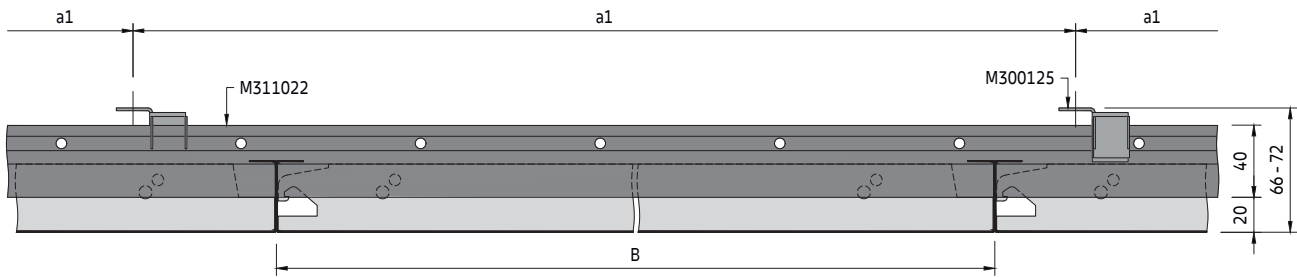

METAL Q-Clip and METAL R-Clip modules are compatible and can be combined with each other.

METAL Q-Clip / METAL Q-Clip F / METAL R-Clip
D02.100.2

Spacing

a2 [mm]	System without additional load		System with additional load +4 kg/m ²		System with additional load +6 kg/m ²	
	a0 [mm]	a1 [mm]	a0 [mm]	a1 [mm]	a0 [mm]	a1 [mm]
500	500	1500	500	1500	500	1500
600	600	1500	600	1500	600	1500
625	625	1500	625	1500	625	1500
650	650	1500	650	1500	650	1200
700	700	1500	700	1200	700	1200
750	750	1500	750	1200	750	1200
800	800	1500	800	1200	800	1200
850	850	1500	850	1200	850	1200
900	900	1500	900	1200	900	1200
950	950	1500	950	1200	950	1200
1000	1000	1500	1000	1200	1000	1200
1050	1050	1500	1050	1200	1050	1200
1100	1100	1500	1100	1200	1100	1200
1150	1150	1500	1150	1200	1150	1200
1200	1200	1200	1200	1200	1200	1200
1250	1250	1200	1250	1200	1250	1000
1300	1300	1200	1300	1200	1300	1000
1350	1350	1200	1350	1000	1350	1000
1400	1400	1200	1400	1000	1400	1000
1450	1450	1200	1450	1000	1450	800
1500	1500	1200	1500	1000	1500	800
1550	1550	1200	1550	1000	1550	800
1600	1600	1200	1600	1000	1600	800
1650	1650	1200	1650	800	1650	800
1700	1700	1000	1700	800	1700	600
1750	1750	1000	1750	800	1750	600
1800	1800	1000	1800	600	1800	600
1850	1850	1000	1850	600	1850	500
1900	1900	800	1900	600	1900	500
1950	1950	800	1950	600	1950	500
2000	2000	800	2000	600	2000	500
2050	2050	800	2050	600	2050	500
2100	2100	800	2100	600	2100	500
2150	2150	800	2150	600	2150	450
2200	2200	800	2200	600	2200	450
2250	2250	800	2250	600	2250	450
2300	2300	800	2300	600	2300	400
2350	2350	800	2350	600	2350	400
2400	2400	800	2400	600	2400	400
2450	2450	800	2450	600	-	-
2500	2500	800	2500	600	-	-

Parameters

- a0 Distance between DP12 A-Bar suspension points
- a1 Max. distance between direct hangers
- a2 Distance between DP12 A-Bars = tile / panel length
- a3 Distance from wall = max. 200 mm
- a4 Distance from wall = max. tile / panel length
- a5 Distance between DP12 A-Bar and top fixing = 38 - 50 mm
- M Module size = tile / panel length / tile / panel width

METAL Q-Clip

M 600 x 600, 625 x 625 mm

METAL Q-Clip F

M 600 x 600, 625 x 625, 1200 x 300, 1200 x 600, 1800 x 400 mm

METAL R-Clip

A Panel length = min. 600 / max. 2500 mm
 B Panel width = min. 250 / max. 600 mm

Typical grid layout

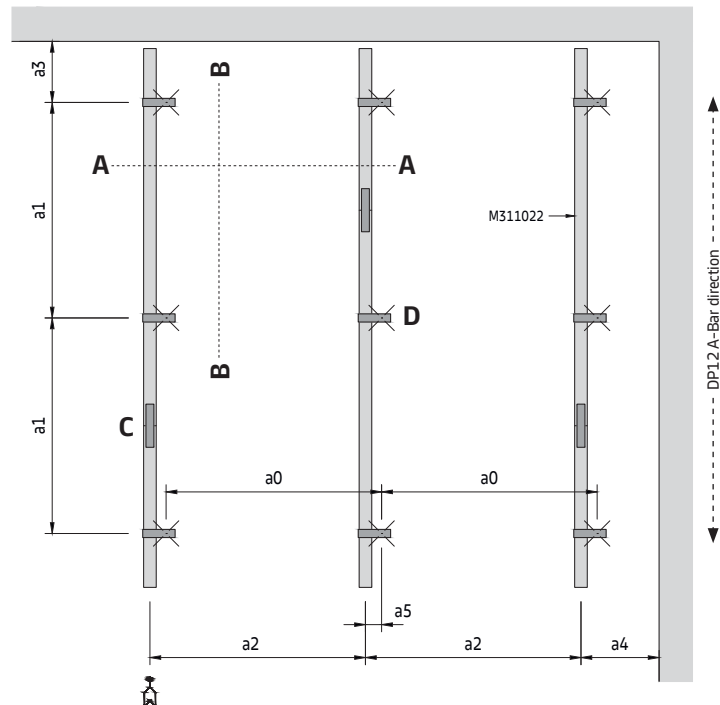

To determine suspension layout

The module length (M) of the requested ceiling is equal to the distance between the DP12 A-Bar centres (a2). On the appropriate spacing table, read down the column headed (a2) to the required module length then read across to determine the suspension point spacing (a0) and direct hanger spacing (a1). The shown values are maximum allowed distances and can be reduced but not exceeded.

METAL Q-Clip / METAL Q-Clip F / METAL R-Clip
D02.100.2

Detail C

Splice connection

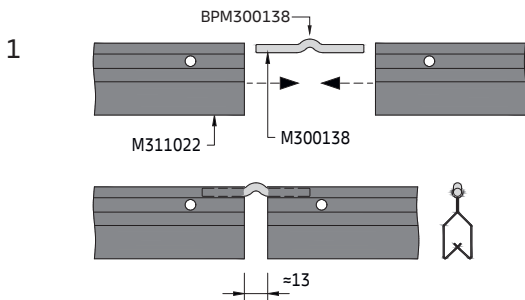

Insert the connection pin at the ends of the DP12 A-Bars and connect them. There is a gap between the DP12 A-Bars. The DP12 A-Bars must be aligned so that the joint is not in the same place as the pips on the tiles / panels.

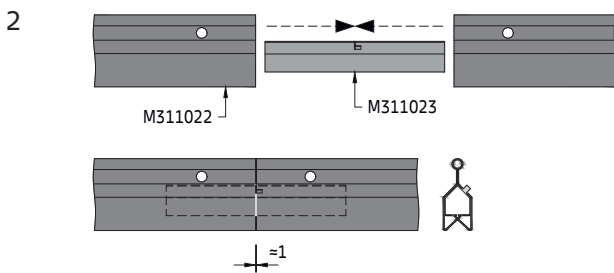

Optionally, the splice connector for DP12 A-Bar can be used. This is inserted at the ends of the DP12 A-Bars and an almost seamless connection is created.

Detail D

Direct hanger installation

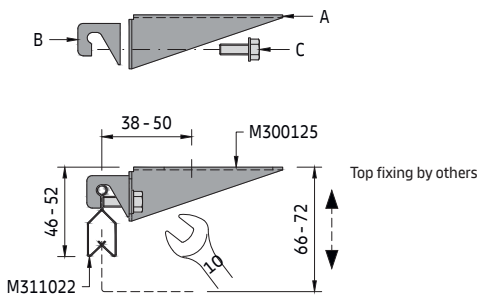

The direct hanger consists of three pre-assembled components (A, B, C). Part A is attached to the soffit first. The distance from the DP12 A-Bar to the attachment point must not exceed 50 mm.

Part B is not tightened, so the DP12 A-Bar can be inserted from below. Tightening the bolt (part C) creates a stable connection. Before that, the height should be set up.

Optional installation

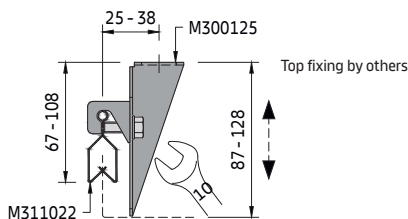

The distance between the DP12 A-Bars should be measured exactly, otherwise the tiles / panels are difficult to install and elements could fall out.

The direct hanger can optionally also be installed vertically. To do this, the components must first be disassembled. The shorter side of part A is then attached to the soffit.

METAL Q-Clip / METAL Q-Clip F / METAL R-Clip
D02.100.2

Detail E

Tile / panel insertion (example with METAL Q-Clip)

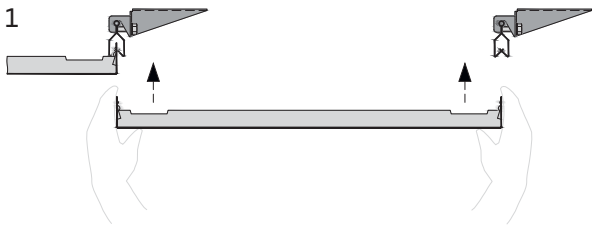

Take the tile / panel and carefully insert it into the DP12 A-Bars from below. All tiles / panels feature a double row of pips. The upper pip is inserted into the DP12 A-Bar, the lower one serves as a stop. Care is required when installing tiles. Always press along the edges with the pips and never on the transverse sides, otherwise the tile may be damaged. The tiles / panels should always be laid in such a way that the WINDOW hooks point in the same direction.



The tiles / panels are correctly inserted when all four corners are flush with the neighbouring tiles / panels. The tiles / panels are designed to match the DP12 A-Bar. If third party profiles are used there is a high probability the tiles will not be correctly inserted.

METAL Q-Clip

METAL R-Clip

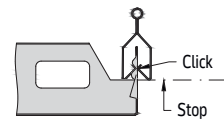
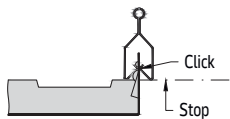

Tile / panel extraction (example with METAL Q-Clip / METAL R-Clip)

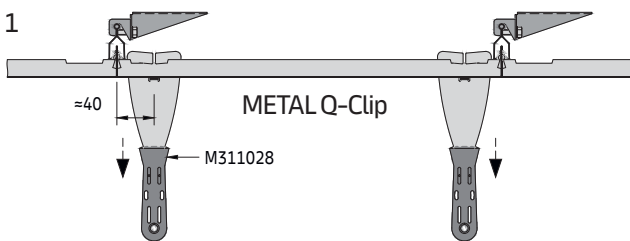

The tiles / panels are designed in such a way that the extraction tool can only be inserted in the designated places so that it clicks into place. There is an indentation on the tiles for this purpose, and a rectangular cut-out on the panels. It is therefore important that the appropriate extraction tool is used. This prevents damage to the tiles / panels. Insert on one side first and pull down with a gentle tug, followed by the opposite side.

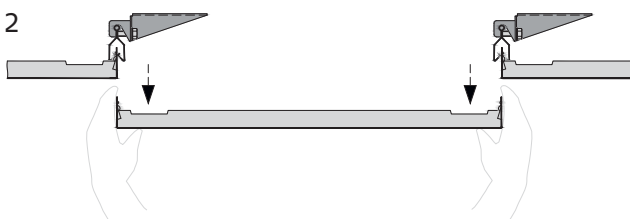
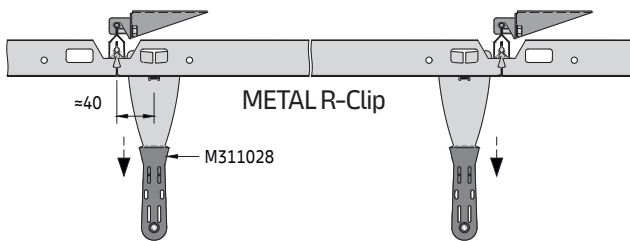

Remove it downwards and store the tile / panel in a safe place so that it cannot be damaged.

METAL Q-Clip / METAL Q-Clip F / METAL R-Clip
D02.100.2

Detail F

Optional security clip

The security clip serves to secure the tiles / panels and prevents them from being removed.

Tile / panel locking

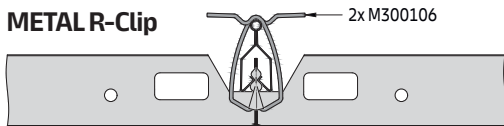
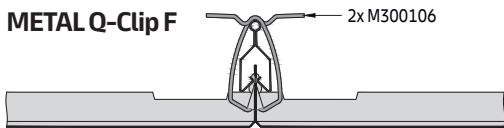
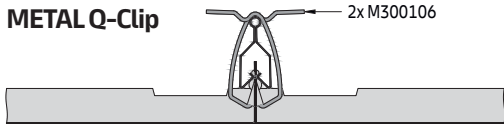

The tiles / panels have, on the sides where the pins are, an embossing where the security clip can be fixed. First hook the security clip into the tile / panel and then slip the upper end over the DP12 A-Bar. Two security clips are required per tile / panel.

Due to the small distance to the soffit, installing the security clips could be more difficult.

Either individual tiles / panels or the entire ceiling can be secured. The tiles / panels are inserted and secured immediately. The last tile / panel cannot be locked.

METAL Q-Clip, METAL Q-Clip F

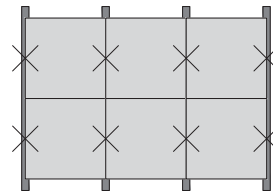

METAL Q-Clip F (rectangular shapes), METAL R-Clip

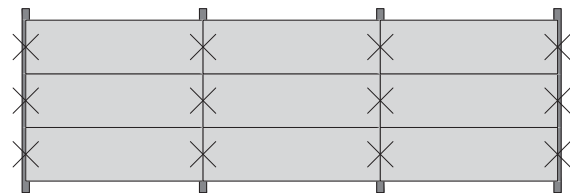

Material required per m² (no waste included)

System without additional load [pcs/m²]

Components		a2 [mm]	500	600	625	1200	1500	1800	2000	2500
M300125	Direct hanger for DP12 A-Bar		1.33	1.11	1.07	0.69	0.56	0.56	0.63	0.50
M300138	Connection pin for DP12 A-Bar		0.50	0.42	0.40	0.21	0.17	0.14	0.13	0.10
M311022	DP12 A-Bar		0.50	0.42	0.40	0.21	0.17	0.14	0.13	0.10

The shown quantities are theoretical and based on an ideal layout, without considering the actual room layout. The ideal layout is based on a calculation of 10 x 10 m (100 m²). This calculation does not allow any damage, spare nor wastage. The final quantities and type of suspension have to be checked before ordering. Soffit and wall fixings by others.

Not including perimeter trims, optional security clips, extraction tools and swing-down brackets.

METAL Q-Clip / METAL Q-Clip F / METAL R-Clip
D02.100.2

Detail G

Optional WINDOW swing-down function

The tiles / panels are provided with two WINDOW hooks, which are used to swing-down. Unlike the standard installation, the tiles / panels are installed alternately (hook to hook) and not in the same direction.

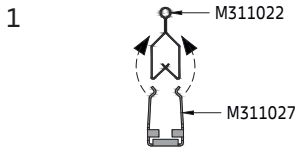

Where the hooks are positioned, the swing-down clip for WINDOW function is placed on the DP12 A-Bar. This is hooked over the DP12 A-Bar from below and fixed with a security clip.

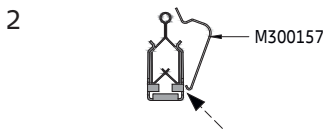

The security clip is first inserted from below and slipped over the DP12 A-Bar. Due to the small distance to the soffit, installing the security clips could be more difficult. The tiles / panels should be inserted at an angle of $\approx 30^\circ$ so that the hook is positioned over the swing-down clip for WINDOW.

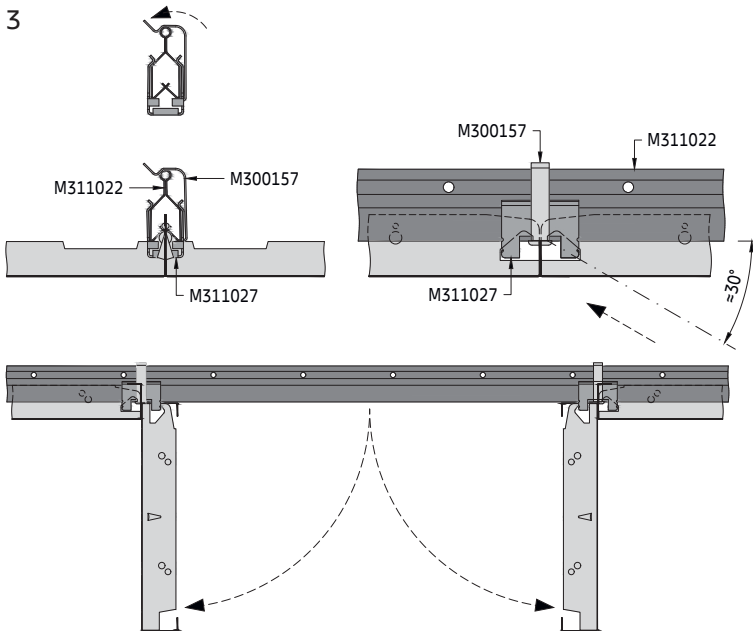

The ceiling is opened with the extraction tool, as shown under detail J.

METAL R-Clip

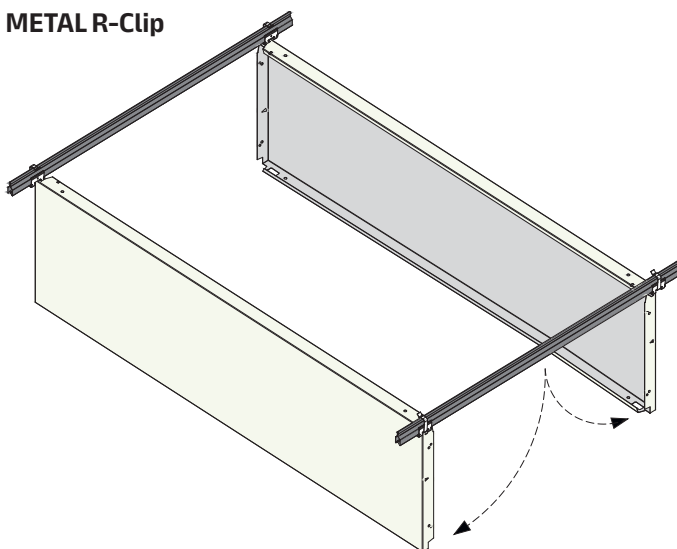

METAL Q-Clip F

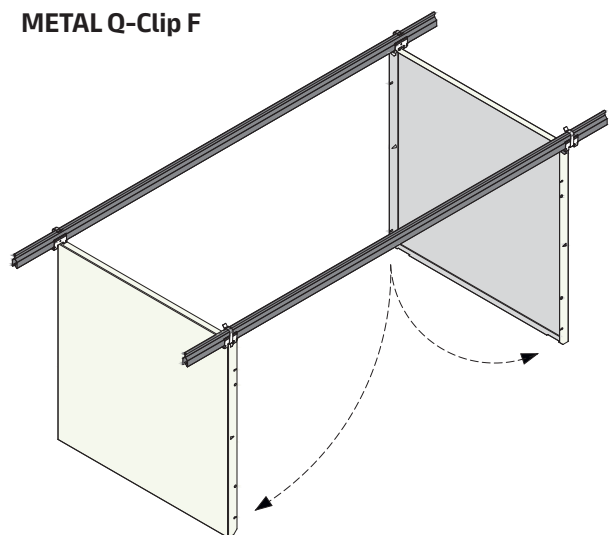

METAL T-Clip F

C-Channel primary grid + Spring-T secondary grid
Concealed grid solution for indoor applications

General information

- Concealed clip-in grid system for small and medium rooms
- For perpendicular installation on C-Channel primary grid
- Spring-T made of galvanised steel
- Typical ceiling weight 5.5 - 6.5 kg/m² (indicative value for unperforated tiles, without additional load)
- Tiles are easily installed and fully demountable
- Optional security clips available

Isometric view

Perimeter solutions on separate datasheet.

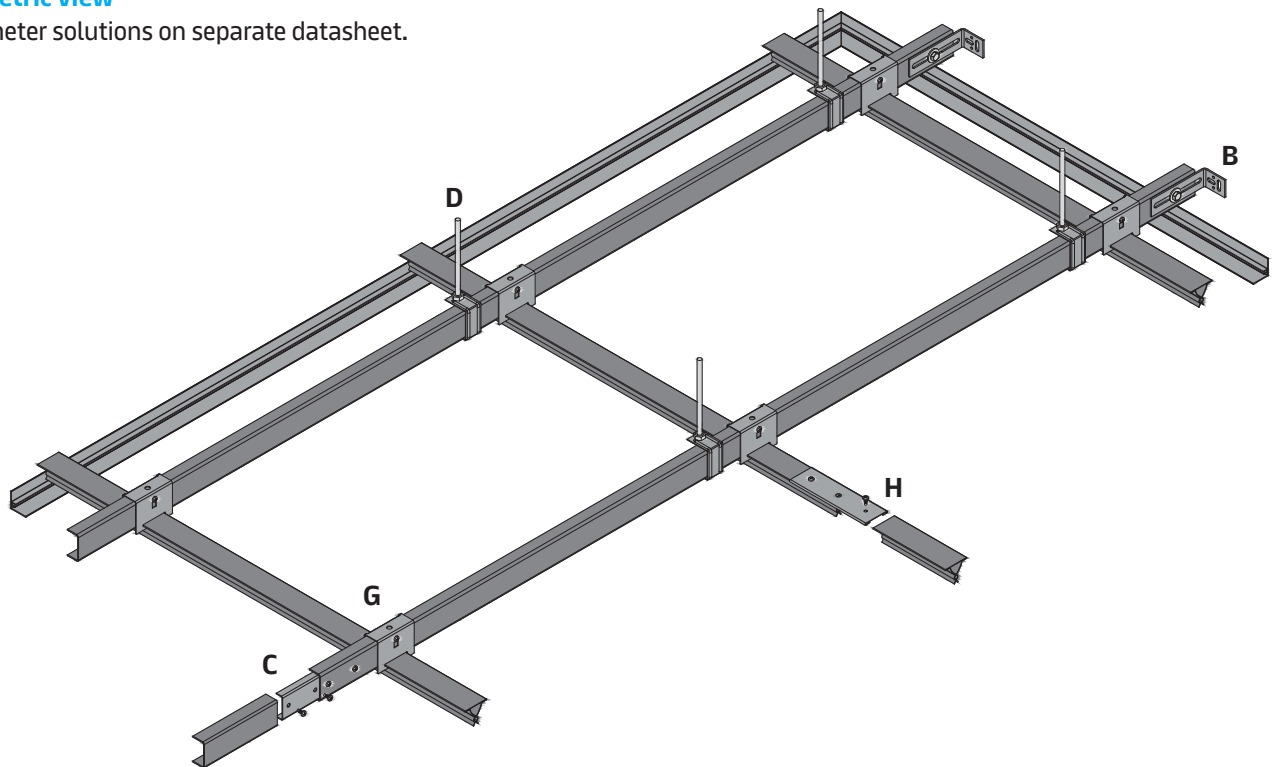

Standard layout

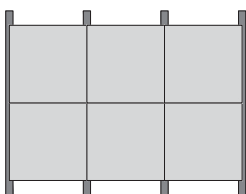

Section E

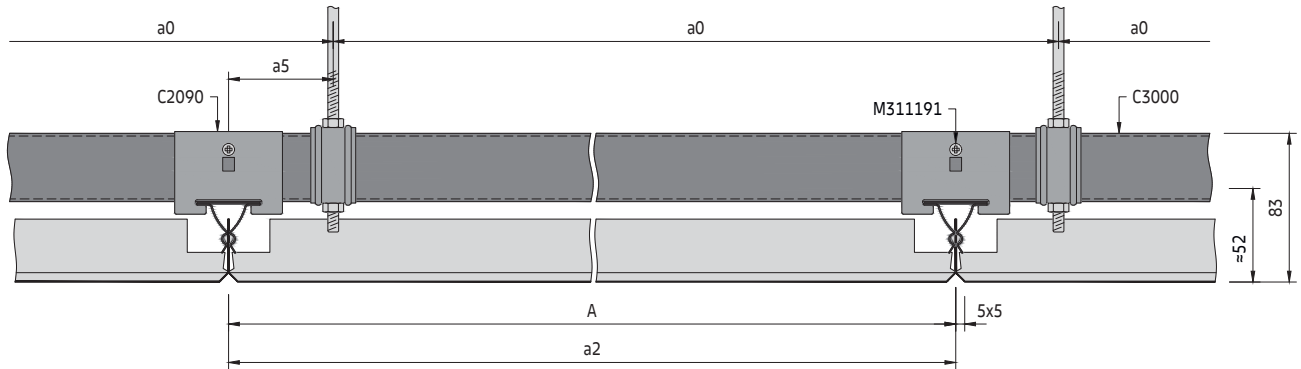

Section F

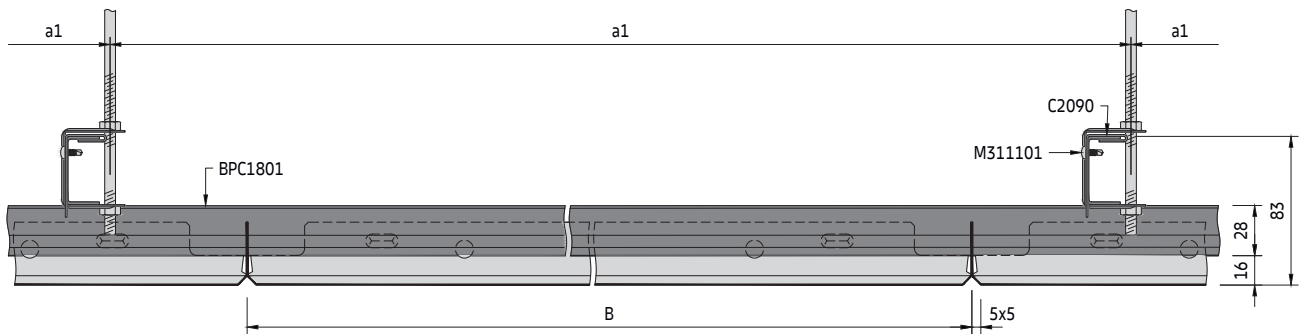

Secondary grid components

Standard components

- C1801 Spring-T
- C1805 Splice connector for Spring-T
- C2090 Hanger for Spring-T
- M311191 Self-drilling screw 3.5 x 9.5 mm

Optional components

- C1775 Security clip
- M311046 Extraction tool

See C-Channel primary grid for primary grid components

Spring-T secondary grid

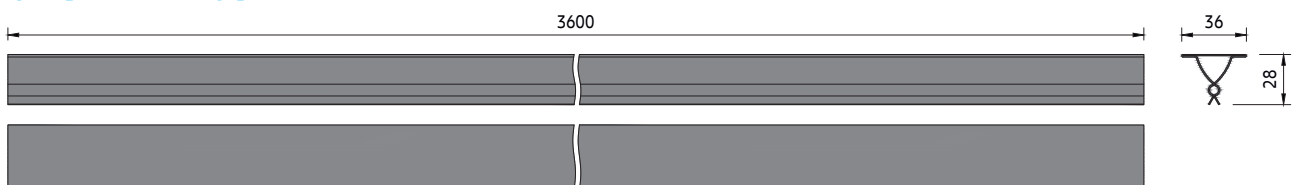

Spacing

a2 [mm]	System without additional load		System with additional load +4 kg/m ²		System with additional load +6 kg/m ²	
	a0 [mm]	a1 [mm]	a0 [mm]	a1 [mm]	a0 [mm]	a1 [mm]
500	1500	1700	1500	1100	1500	700
600	1200	1800	1200	1600	1200	1150
675	1350	1700	1350	1400	1350	900
750	1500	1600	750	1450	750	1350
900	900	1500	900	1300	900	1250
1200	1200	1300	1200	1150	1200	1150
1500	1500	1150	1500	1050	1500	700

Parameters

- a0 Distance between C-Channel suspension points = max. 1900 mm
- a1 Max. distance between C-Channels
- a2 Distance between Spring-T = tile length
- a3 Distance from wall = max. 200 mm
- a4 Distance from wall = max. tile length
- a5 Distance from C-Channel suspension point to hanger = max. 100 mm
- M Module size = tile length / tile width = 600 x 600 mm

Typical grid layout

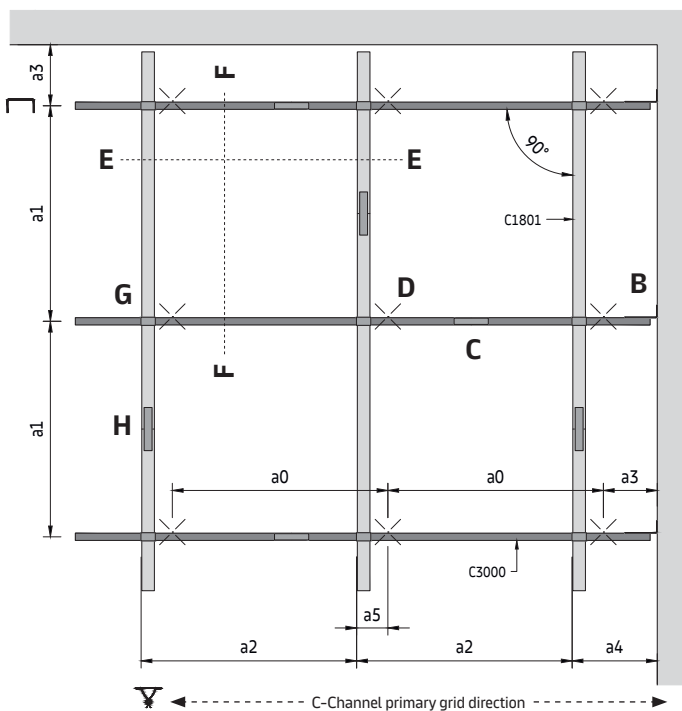

To determine suspension layout

The module length (M) of the requested ceiling is equal to the distance between the Spring-T centres (a2).

On the appropriate spacing table, read down the column headed (a2) to the required module length then read across to determine the suspension point spacing (a0) and U-Profile spacing (a1).

The shown values are maximum allowed distances and can be reduced but not exceeded.

Detail G

Hanger installation

- 1

Insert the hanger for DP12 A-Bar from the end of the Spring-T.

- 2

Place the Spring-T including the hanger on the C-Channel. Bend the top flap of the hanger down 180°.

- 3

Take a self-drilling screw and fix the position of the hanger on the C-Channel.

- 4

The DP12 A-Bar is now locked in position. The slot in the hanger is wider than the Spring-T. This is important because it allows any tolerances to be compensated. Otherwise the tiles could no longer be inserted after a certain point.

Detail H

Splice connection

- 1

Insert the splice connector for Spring-T at the end of the Spring-T and connect both profiles.

- 2

The position of the splice connector is held with two self-drilling screws.

Top view

Detail I

Tile insertion

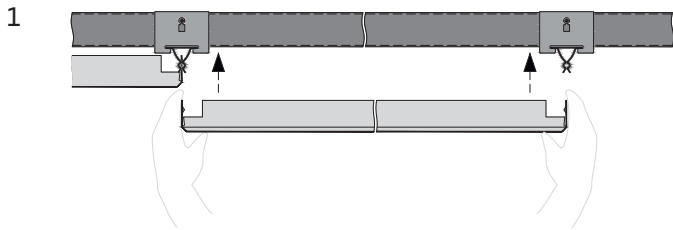

Take the tile and carefully insert it into the Spring-T from below. Be careful with the tiles. Always press along the edges with the pips and never on the transverse sides, otherwise the tile may be damaged.

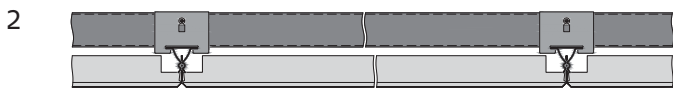

The tiles are correctly inserted when all four corners are flush with the neighbouring tiles. The tiles are designed to match the Spring-T. If third party profiles are used there is a high probability the tiles will not be correctly inserted.

Tile extraction

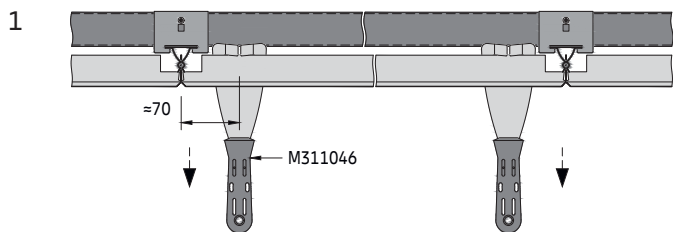

Insert the extraction tool on one side first and pull down with a gentle tug, followed by the opposite side.

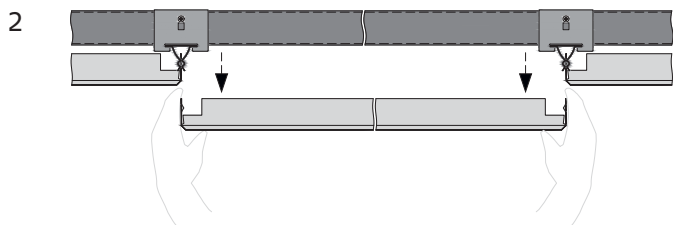

Remove it downwards and store the tile in a safe place so that it cannot be damaged.

METAL T-Clip F

D02.102

Material required per m² (no waste included)

System without additional load [pcs/m²]

Components		a2 [mm]	500	600	675	750	1200	1500	2000	2500
C1801	Spring-T		0.55	0.46	0.41	0.37	0.23	0.19	0.14	0.11
C1805	Splice connector for Spring-T		0.56	0.48	0.42	0.38	0.24	0.20	0.14	0.12
C2090	Hanger for Spring-T		1.18	0.94	0.88	0.84	0.66	0.58	0.50	0.46
C3000	C-Channel		0.19	0.17	0.19	0.20	0.24	0.27	0.31	0.35
C7140	Splice connector for C-Channel		0.15	0.15	0.15	0.18	0.20	0.23	0.25	0.30
CA97	Clamping bracket for C-Channel		0.40	0.47	0.44	0.42	0.65	0.58	1.00	0.89
M300140	Wall anchor		0.06	0.06	0.06	0.07	0.08	0.09	0.11	0.12
M311099	Threaded rod M6 x 1000 mm		0.40	0.47	0.44	0.42	0.65	0.58	1.00	0.89
M311103	Hexagonal nut M6		0.30	0.30	0.30	0.30	0.30	0.30	0.30	0.30
M311105	Washer		0.10	0.10	0.10	0.10	0.10	0.10	0.10	0.10
M311191	Self-drilling screw 3.5 x 9.5 mm		2.30	1.90	1.72	1.60	1.14	0.98	0.78	0.70
M311303	Hexagonal bolt M6 x 16 mm		0.10	0.10	0.10	0.10	0.10	0.10	0.10	0.10

The shown quantities are theoretical and based on an ideal layout, without considering the actual room layout. The ideal layout is based on a calculation of 10 x 10 m (100 m²). This calculation does not allow any damage, spare nor wastage. The final quantities and type of suspension have to be checked before ordering. Soffit and wall fixings by others. Not including perimeter trims, optional security clips, extraction tools and swing-down brackets.

METAL T-Clip F

U-Profile primary grid + Spring-T secondary grid
Concealed grid solution for indoor applications

General information

- Concealed clip-in grid system for small and medium rooms
- For perpendicular installation on U-Profile primary grid
- Spring-T made of galvanised steel
- Typical ceiling weight 5.5 - 6.5 kg/m² (indicative value for unperforated tiles, without additional load)
- Tiles are easily installed and fully demountable
- Optional security clips available

Isometric view

Perimeter solutions on separate datasheet.

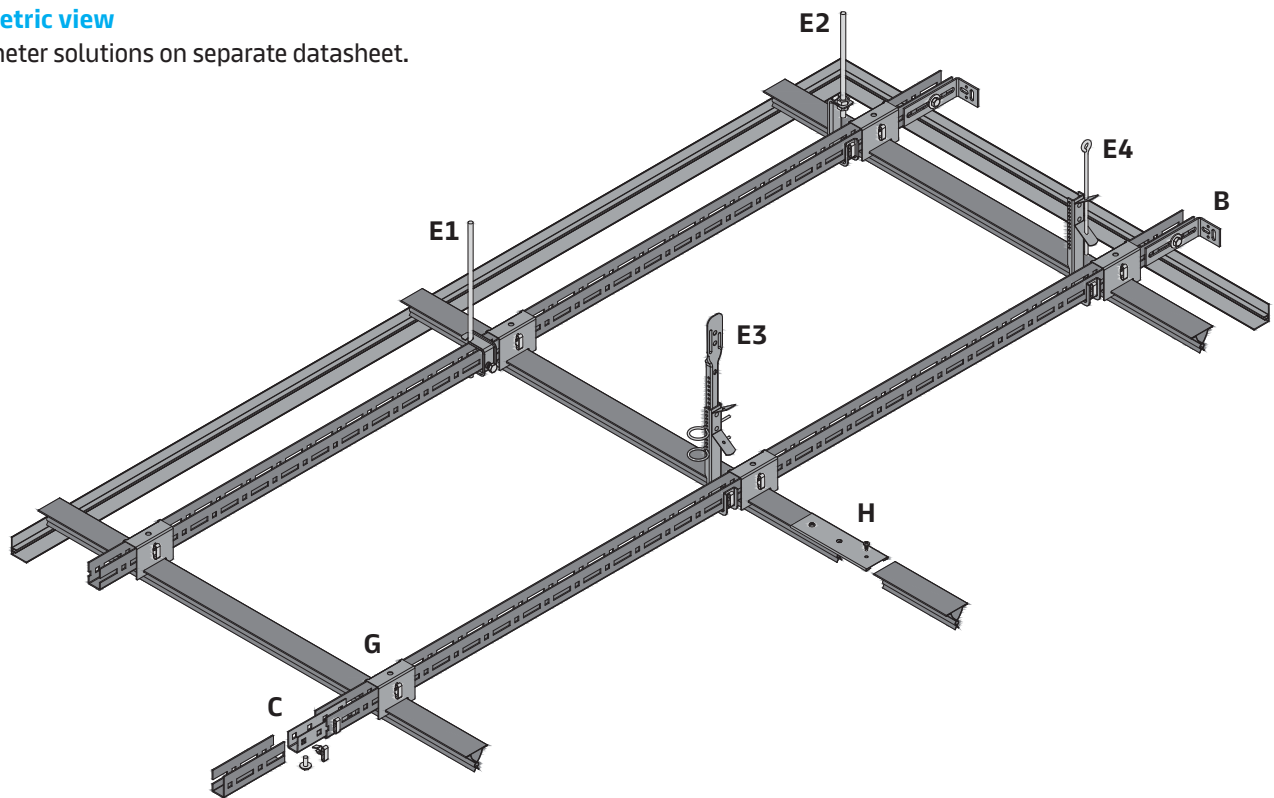

Standard layout

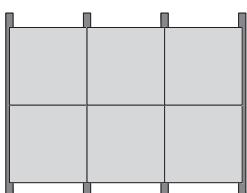

Section E

Example with suspension option E1

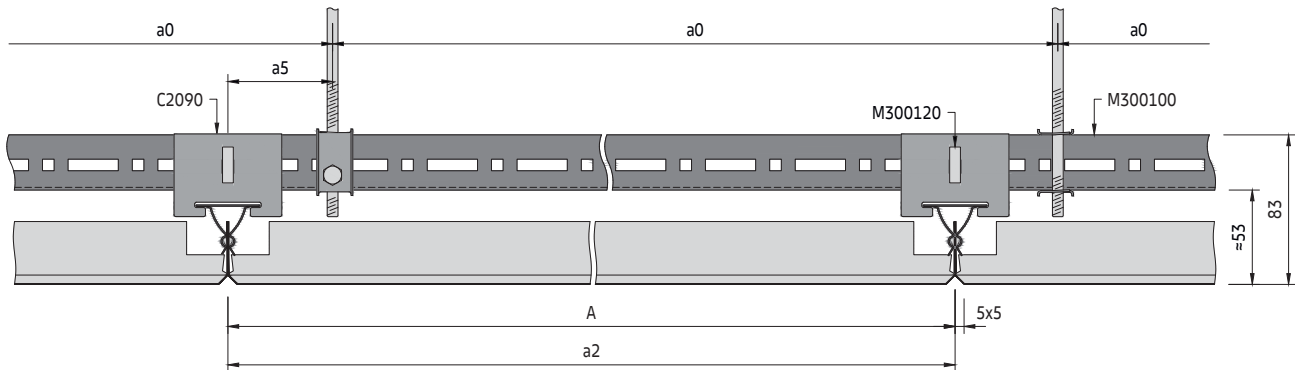

Section F

Example with suspension option E1

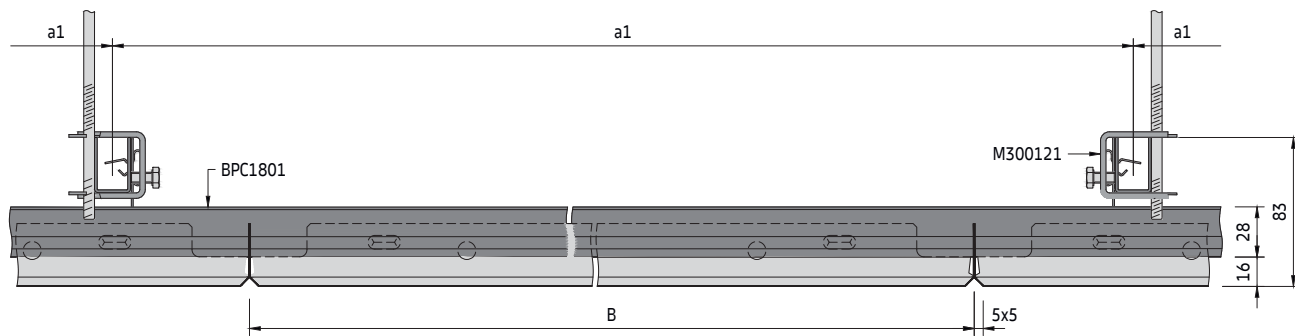

Secondary grid components

Standard components

- C1801 Spring-T
- C1805 Splice connector for Spring-T
- C2090 Hanger for Spring-T
- M311191 Self-drilling screw 3.5 x 9.5 mm

Optional components

- C1775 Security clip
- M311046 Extraction tool

See C-Channel primary grid for primary grid components

Spring-T secondary grid

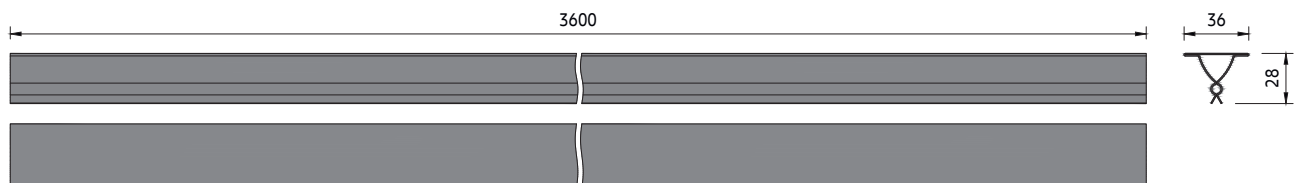

Spacing

a2 [mm]	System without additional load		System with additional load +4 kg/m ²		System with additional load +6 kg/m ²	
	a0 [mm]	a1 [mm]	a0 [mm]	a1 [mm]	a0 [mm]	a1 [mm]
500	1500	1700	1500	1100	1500	850
600	1200	1800	1200	1600	1200	1350
675	1350	1650	1350	1300	1350	1050
750	1500	1600	750	1450	750	1350
900	900	1500	900	1300	900	1250
1200	1200	1300	1200	1150	1200	1150
1500	1500	1150	1500	1050	1500	850

Parameters

- a0 Distance between U-Profile suspension points = max. 1900 mm
- a1 Max. distance between U-Profile
- a2 Distance between Spring-T = tile length
- a3 Distance from wall = max. 200 mm
- a4 Distance from wall = max. tile length
- a5 Distance from U-Profile suspension point to hanger = max. 100 mm
- M Module size = tile length / tile width = 600 x 600 mm

Typical grid layout

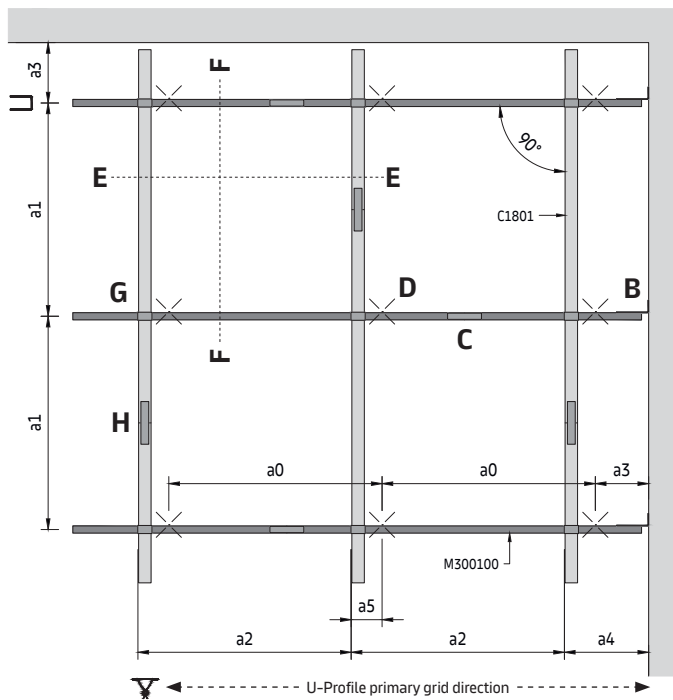

To determine suspension layout

The module length (M) of the requested ceiling is equal to the distance between the Spring-T centres (a2).

On the appropriate spacing table, read down the column headed (a2) to the required module length then read across to determine the suspension point spacing (a0) and U-Profile spacing (a1).

The shown values are maximum allowed distances and can be reduced but not exceeded.

METAL T-Clip F
D02.102.1

Detail G

Hanger installation

- 1

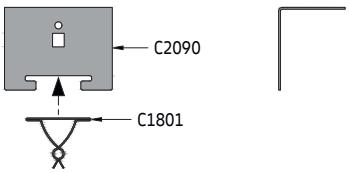

Insert the hanger for Spring-T from the end of the Spring-T.

- 2

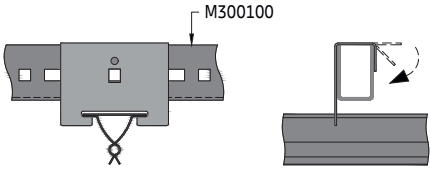

Place the Spring-T including the hanger on the U-Profile. Bend the top flap of the hanger down 90°.

- 3

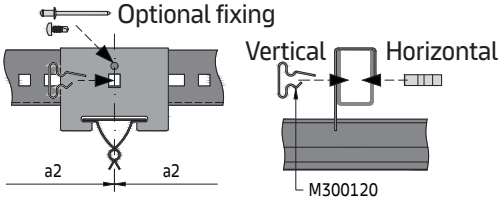

Fix it with plug-in clips at the specified module spacing (inserted vertically or horizontally). If the panel size does not fit with the modulation of the U-Profile (steps of 25 mm), the plug-in clip needs to be inserted into a long hole. The hanger position could be fixed by using a pop-riquet or self-drilling screw.

- 4

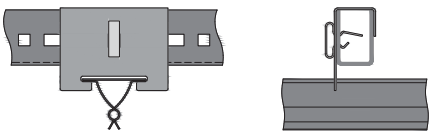

The Spring-T is now locked in position. The slot in the hanger is wider than the Spring-T. This is important because it allows any tolerances to be compensated. Otherwise the tiles will no longer be inserted after a certain point.

Detail H

Splice connection

- 1



Insert the splice connector for Spring-T at the end of the Spring-T and connect both profiles.

- 2

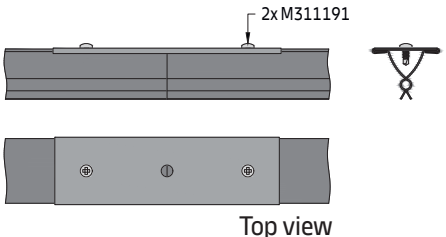

The position of the splice connector is held with two self-drilling screws.

Detail I

Tile insertion

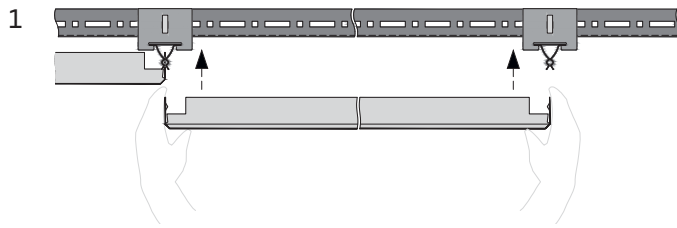

Take the tile and carefully insert it into the Spring-T from below. Be careful with the tiles. Always press along the edges with the pips and never on the transverse sides, otherwise the tile may be damaged.

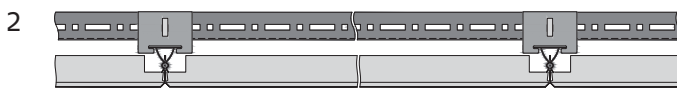

The tiles are correctly inserted when all four corners are flush with the neighbouring tiles. The tiles are designed to match the Spring-T. If third party profiles are used there is a high probability the tiles will not be correctly inserted.

Tile extraction

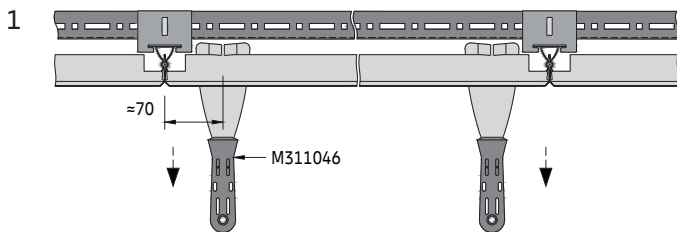

Insert the extraction tool on one side first and pull down with a gentle tug, followed by the opposite side.

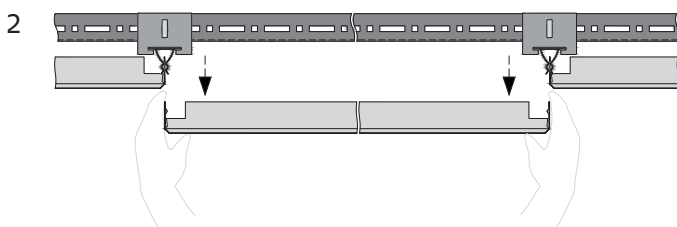

Remove it downwards and store the tile in a safe place so that it cannot be damaged.

Material required per m² (no waste included)**System without additional load [pcs/m²]**

Components		a2 [mm]	500	600	675	750	1200	1500	2000	2500
C1801	Spring-T		0.55	0.46	0.41	0.37	0.23	0.19	0.14	0.11
C1805	Splice connector for Spring-T		0.56	0.48	0.42	0.38	0.24	0.20	0.14	0.12
C2090	Hanger for Spring-T		1.18	0.94	0.88	0.84	0.66	0.58	0.50	0.46
M300100	U-Profile		0.16	0.15	0.16	0.17	0.21	0.23	0.27	0.30
M300119	Splice connector for U-Profile		0.16	0.15	0.17	0.17	0.21	0.24	0.27	0.30
M300120	Plug-in clip for U-Profile		1.50	1.20	1.20	0.12	1.07	1.06	1.04	1.05
M300140	Wall anchor		0.06	0.06	0.06	0.07	0.08	0.09	0.11	0.12
M311103	Hexagonal nut M6		0.30	0.30	0.30	0.30	0.30	0.30	0.30	0.30
M311105	Washer		0.10	0.10	0.10	0.10	0.10	0.10	0.10	0.10
M311191	Self-drilling screw 3.5 x 9.5 mm		2.30	1.90	1.72	1.60	1.14	0.98	0.78	0.70
Various	Suspension points (E1 - E4)		0.59	0.47	0.45	0.42	0.65	0.58	1.00	0.89

The shown quantities are theoretical and based on an ideal layout, without considering the actual room layout. The ideal layout is based on a calculation of 10 x 10 m (100 m²). This calculation does not allow any damage, spare nor wastage. The final quantities and type of suspension have to be checked before ordering. Soffit and wall fixings by others.

Not including perimeter trims, optional security clips, extraction tools and swing-down brackets.

METAL K-Clip

U-Profile primary grid + DP12 A-Bar secondary grid
Concealed grid solution for indoor applications

General information

- Concealed clip-in tartan grid system for large rooms
- Layouts with METAL Q-Clip tiles or METAL R-Clip panels in combination with crossing boxes and strips
- For perpendicular installation on U-Profile primary grid
- DP12 A-Bar made of galvanised steel
- Crossing box and strips in RAL 9010 made of galvanised steel (further sizes, cut-outs and colour options on request)
- Typical ceiling weight 6.0 kg/m² (with METAL Q-Clip), 7.0 kg/m² (with METAL R-Clip) (indicative value for unperforated tiles / panels, without additional load)
- Tiles / panels are easily installed and fully demountable
- Optional security clips available for tiles / panels

Isometric view

Select the suspension option E1 - E4.
Perimeter solutions on separate datasheet.

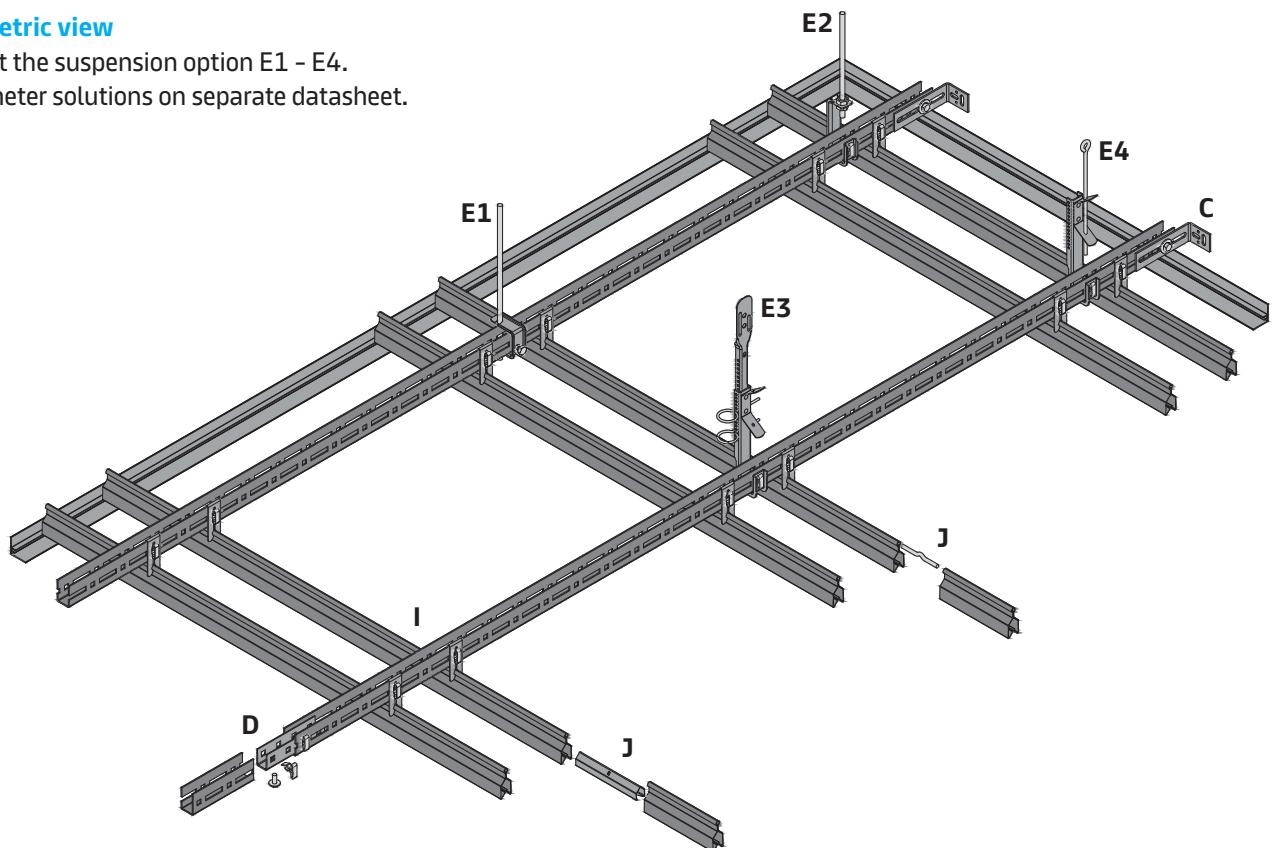

Standard, Vario Design layout options

Standard with METAL Q-Clip tiles

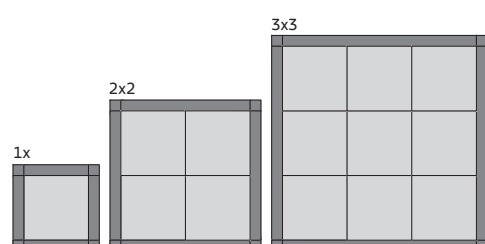

Vario Design with METAL R-Clip tiles



METAL K-Clip

D02.103

Section F (with 1x METAL Q-Clip)

Example with suspension option E1

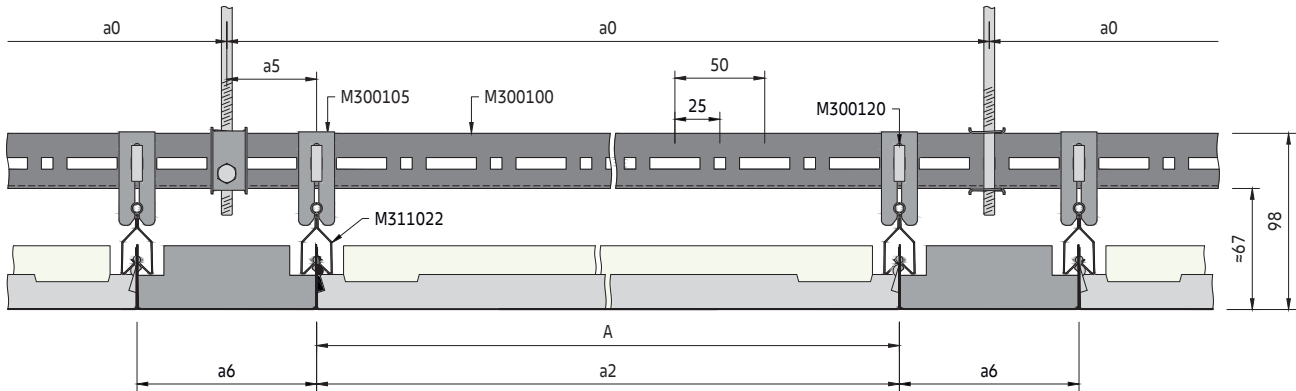

Section F (with METAL R-Clip)

Example with suspension option E1

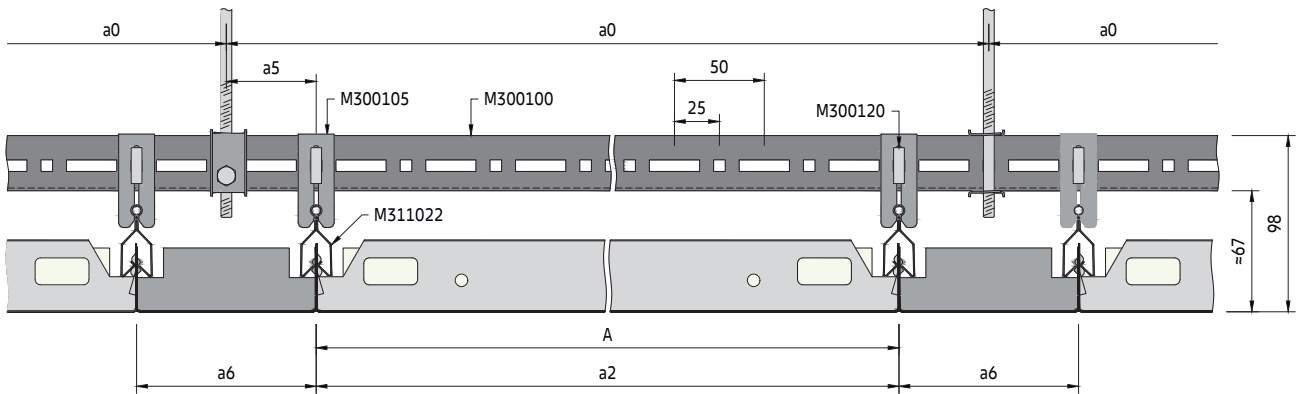

Secondary grid components

Standard components

- M311022 DP12 A-Bar
- M300138 Connection pin for DP12 A-Bar
- M300105 Hanger for DP12 A-Bar
- M300120 Plug-in clip for U-Profile

Optional components

- M300106 Security clip
- M311023 Splice connector for DP12 A-Bar
- M311028 Extraction tool
- M311191 Self-drilling screw 3.5 x 9.5 mm

See U-Profile primary grid for primary grid components

DP12 A-Bar secondary grid

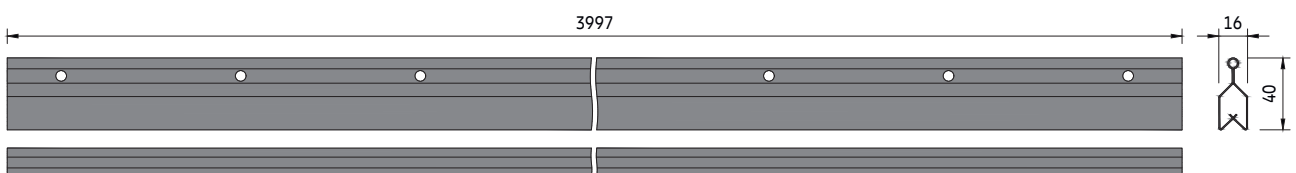

METAL K-Clip

D02.103

Section G (with 1x METAL Q-Clip)

Example with suspension option E1

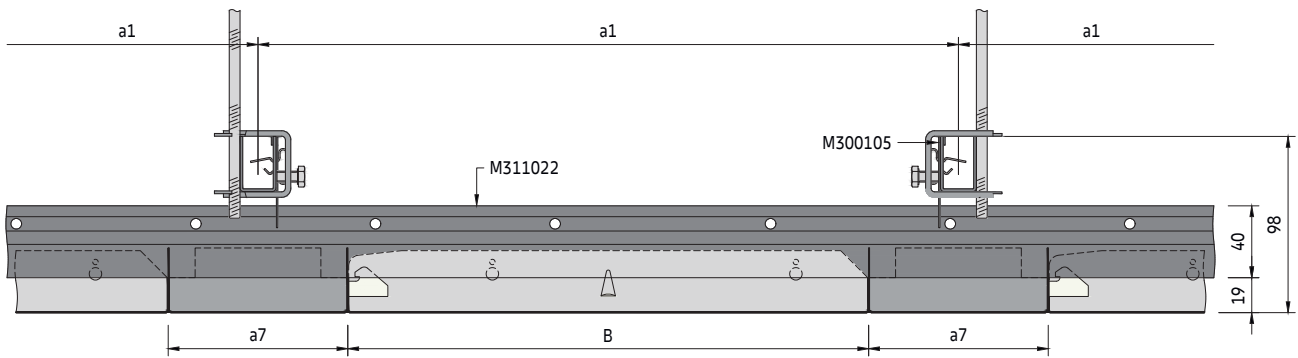

Section G (with METAL R-Clip)

Example with suspension option E1

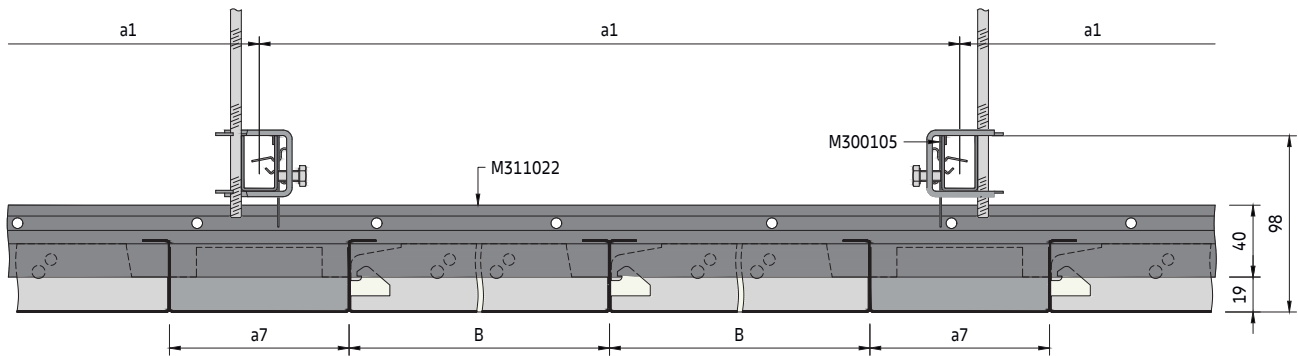

Crossing box & strips

Crossing box

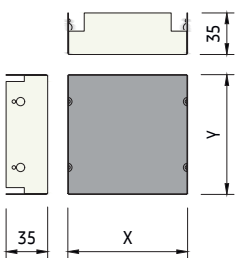

Strip (for 1x METAL Q-Clip)

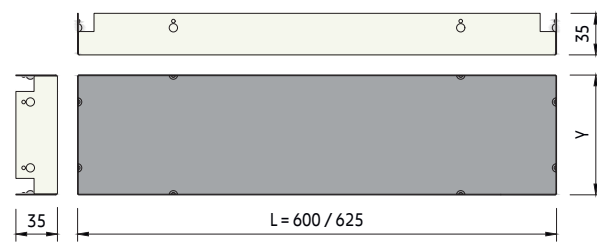

Strip (for METAL R-Clip)

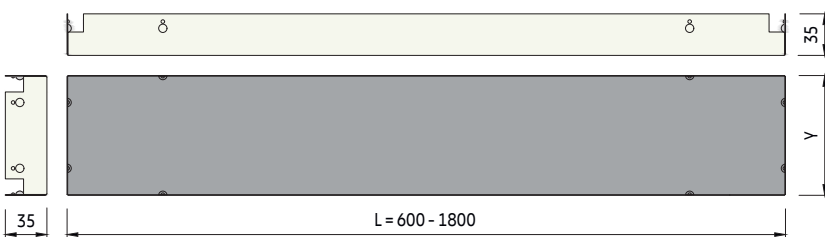

The strips are delivered with pips on all four sides. This allows the same strip to be installed lengthwise and crosswise.

METAL K-Clip

D02.103

Spacing

a2 [mm]	System without additional load		System with additional load +4 kg/m ²		System with additional load +6 kg/m ²	
	a0 [mm]	a1 [mm]	a0 [mm]	a1 [mm]	a0 [mm]	a1 [mm]
700	1400	1750	1400	1250	1400	1000
725	1450	1750	1450	1250	1450	900
750	1500	1650	750	1550	750	1500
775	1550	1550	775	1550	775	1500
1300	1300	1300	1300	1200	1300	1150
1325	1325	1300	1325	1200	1325	1100
1350	1350	1300	1350	1150	1350	1050
1375	1375	1300	1375	1150	1375	1000
1400	1400	1300	1400	1150	1400	1000
1450	1450	1250	1450	1100	1450	900
1500	1500	1250	1500	1100	1500	850
1550	1550	1200	1550	1050	1550	800
1600	1600	1200	1600	1000	1600	750
1650	1650	1200	1650	900	1650	700
1700	1700	1150	1700	850	1700	650
1750	1750	1150	1750	800	1750	600
1800	1800	1100	1800	700	900	1150
1850	1850	1000	1850	650	925	1100
1900	1900	950	1900	600	950	1100
1925	963	1100	963	950	963	1100
1950	975	1100	975	950	975	1100
1975	988	1050	988	950	988	1100
2000	1000	1050	1000	950	1000	1100
2025	1013	1050	1013	950	1013	1100

Parameters

- a0 Distance between U-Profile suspension points = max. 1900 mm
- a1 Max. distance between U-Profiles
- a2 Distance between DP12 A-Bars = tile/panel length
- a3 Distance from wall = max. 200 mm
- a4 Distance from wall = max. tile/panel length
- a5 Distance from U-Profile suspension point to hanger = max. 100 mm
- a6 Crossing box length (X) / strip width (Y) = 100, 125, 150 mm
- a7 Crossing box width (Y) / strip width (Y) = 100, 125, 150 mm
- M Module length = tile/panel length + strip width
Module width = tile/panel width (2, 3 or 4x) + strip width

METAL Q-Clip

- M 600 x 600, 625 x 625 mm

METAL R-Clip

- A Panel length = min. 600 / max. 1800 mm
- B Panel width = min. 250 / max. 600 mm

To determine suspension layout

The module length (M) of the requested ceiling is equal to the distance between the DP12 A-Bar centres (a2). On the appropriate spacing table, read down the column headed (a2) to the required module length then read across to determine the suspension point spacing (a0) and U-Profile spacing (a1). The shown values are maximum allowed distances and can be reduced but not exceeded.

Typical grid layout

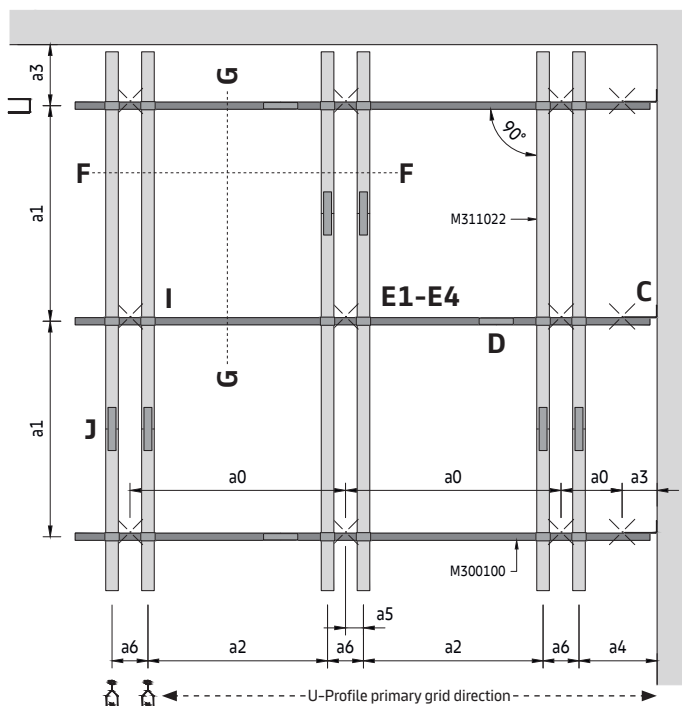

METAL K-Clip

D02.103

Section H (with 2x2 METAL Q-Clip)

Example with suspension option E1

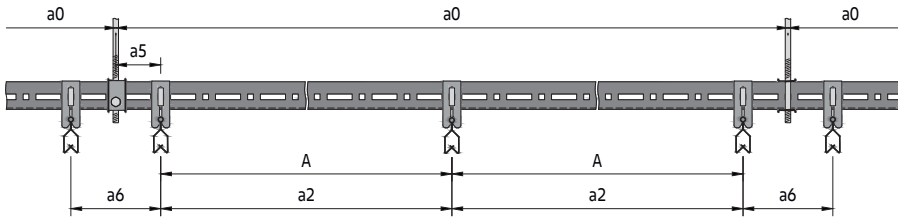

Section H (with 3x3 METAL Q-Clip)

Example with suspension option E1

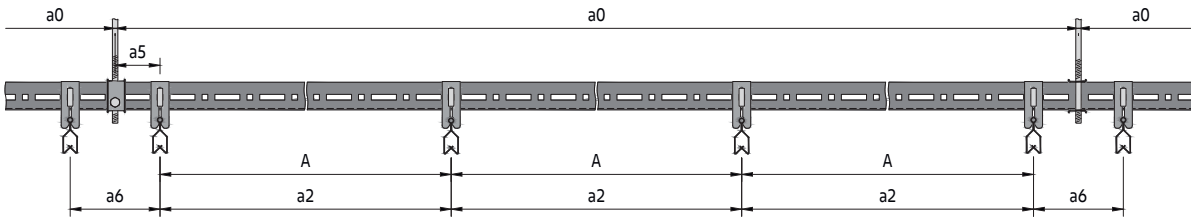

Section H (with 3x3 METAL Q-Clip)

Example with suspension option E1, module size >1900 mm

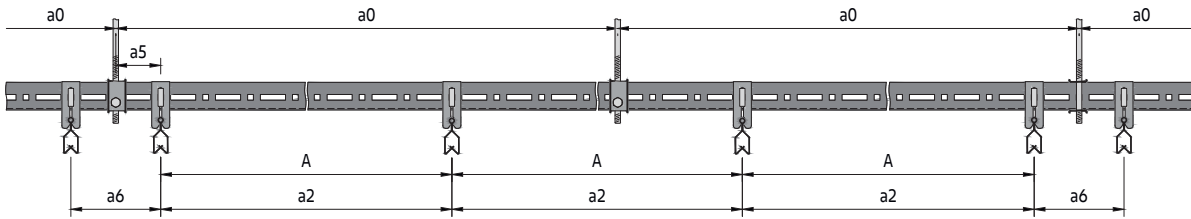

Crossing box & strips

Crossing box

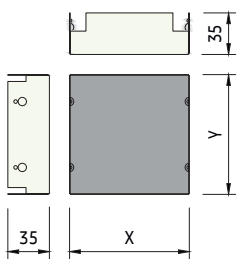

Strip (for 2x2 METAL Q-Clip)

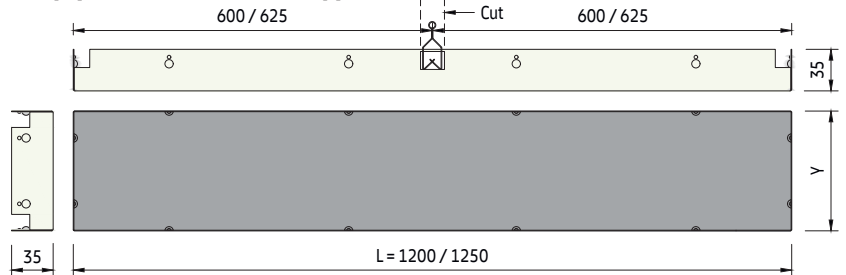

Strip (for 3x3 METAL Q-Clip)

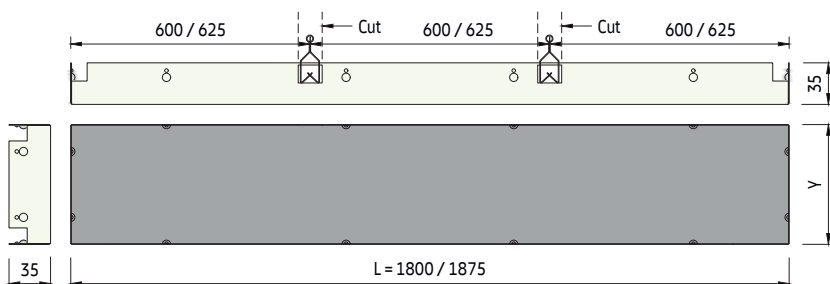

The strips are delivered with pips on all four sides. This allows the same strip to be installed lengthwise and crosswise. There are notches on the long sides that are cut away on site to allow the DP12 A-Bar to pass through.

METAL K-Clip

D02.103

Spacing

a2 [mm]	System without additional load		System with additional load +4 kg/m ²		System with additional load +6 kg/m ²	
	a0 [mm]	a1 [mm]	a0 [mm]	a1 [mm]	a0 [mm]	a1 [mm]
700	1400	1750	1400	1250	1400	1000
725	1450	1750	1450	1250	1450	900
750	1500	1650	750	1550	750	1500
775	1550	1550	775	1550	775	1500
1300	1300	1300	1300	1200	1300	1150
1325	1325	1300	1325	1200	1325	1100
1350	1350	1300	1350	1150	1350	1050
1375	1375	1300	1375	1150	1375	1000
1400	1400	1300	1400	1150	1400	1000
1450	1450	1250	1450	1100	1450	900
1500	1500	1250	1500	1100	1500	850
1550	1550	1200	1550	1050	1550	800
1600	1600	1200	1600	1000	1600	750
1650	1650	1200	1650	900	1650	700
1700	1700	1150	1700	850	1700	650
1750	1750	1150	1750	800	1750	600
1800	1800	1100	1800	700	900	1150
1850	1850	1000	1850	650	925	1100
1900	1900	950	1900	600	950	1100
1925	963	1100	963	950	963	1100
1950	975	1100	975	950	975	1100
1975	988	1050	988	950	988	1100
2000	1000	1050	1000	950	1000	1100
2025	1013	1050	1013	950	1013	1100

Parameters

- a0 Distance between U-Profile suspension points = max. 1900 mm
- a1 Max. distance between U-Profiles
- a2 Distance between DP12 A-Bars = tile length
- a3 Distance from wall = max. 200 mm
- a4 Distance from wall = max. tile length
- a5 Distance from U-Profile suspension point to hanger = max. 100 mm
- a6 Crossing box length (X) / strip width (Y) = 100, 125, 150 mm
- a7 Crossing box width (Y) / strip width (Y) = 100, 125, 150 mm
- M Module length = tile length (2 or 3x) + strip width
Module width = tile width (2 or 3x) + strip width

METAL Q-Clip

- M 600 x 600, 625 x 625 mm

To determine suspension layout

The module length (M) of the requested ceiling is equal to the distance between the DP12 A-Bar centres (a2).

On the appropriate spacing table, read down the column headed (a2) to the required module length then read across to determine the suspension point spacing (a0) and U-Profile spacing (a1).

The shown values are maximum allowed distances and can be reduced but not exceeded.

Typical grid layout

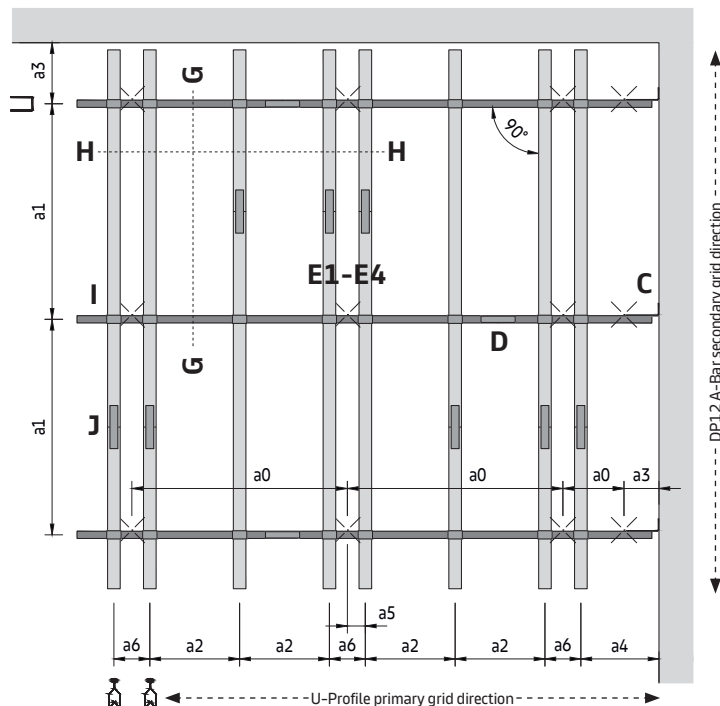

METAL K-Clip
D02.103

Detail I

Hanger installation

1

The hanger for DP12 A-Bar is made of spring steel and is therefore elastic. It is twisted on the DP12 A-Bar from above. Then it can be slid to the correct position.

2

Hang the DP12 A-Bar with the hangers under the U-Profile.

3

Fix hanger with plug-in clips at the specified module spacing (inserted vertically or horizontally). If the panel size does not fit with the modulation of the U-Profile (25 mm increments), the plug-in clip needs to be inserted into a long hole. The hanger position can alternatively be fixed by using a pop-rivet or self-drilling screw.

4

The DP12 A-Bar is now locked in position. Due to the round head of the DP12 A-Bar, it can swing. This is important, because it allows any tolerances to be compensated. Otherwise the tiles/panels could no longer be inserted after a certain point.

Detail J

Splice connection

1

Insert the connection pin at the ends of the DP12 A-Bars and connect them. There is a gap between the DP12 A-Bars. The DP12 A-Bars must be aligned so that the joint is not in the same place as the pips on the tiles/panels.

2

Optionally, the splice connector for DP12 A-Bar can be used. This is inserted at the ends of the DP12 A-Bars and an almost seamless connection is created.

METAL K-Clip

D02.103

Detail K

Tile/panel insertion

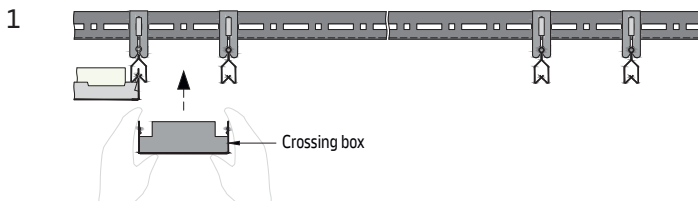

The components are installed continuously. Take the crossing box and insert into the DP12 A-Bars from below. The crossing box has pips on two sides, so it must always be laid in the same direction. The upper pip is clamped into the DP12 A-Bar.

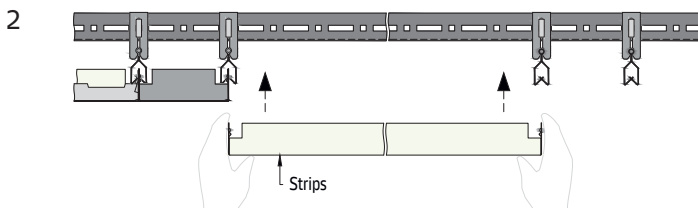

The strips feature pips on all four sides. This allows them to be inserted lengthwise and crosswise into the DP12 A-Bar.

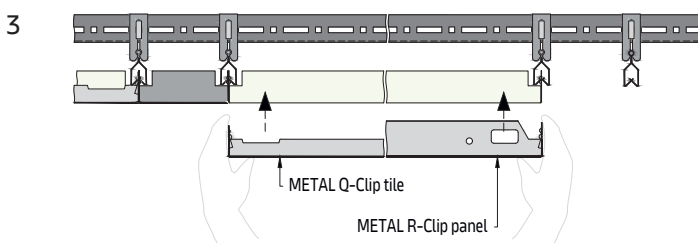

Take the tile/panel and carefully insert it into the DP12 A-Bars from below. All tiles/panels feature a double row of pips. The upper pip is inserted into the DP12 A-Bar, the lower one serves as a stop. Care is required when installing tiles/panels. Always press along the edges with the pips and never on the transverse sides, otherwise the tile may be damaged. The tiles/panels should always be laid in such a way that the WINDOW hooks point in the same direction.

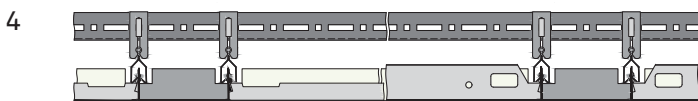

The tiles/panels are correctly inserted when all four corners are flush with the neighbouring tiles/panels. The tiles/panels are designed to match the DP12 A-Bar. If third party profiles are used there is a high probability the tiles will not be correctly inserted.

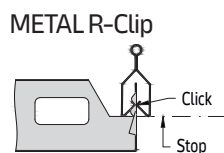
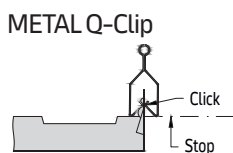

Tile/panel extraction

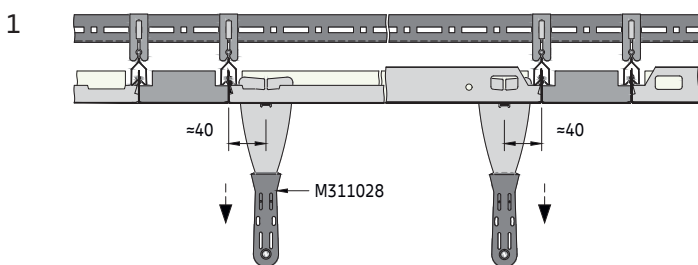

The tiles/panels are designed in such a way that the extraction tool can only be inserted in the designated places so that it clicks into place. There is an indentation on the tiles for this purpose, and a rectangular cut-out on the panels. It is therefore important that the appropriate extraction tool is used. This prevents damage to the tiles/panels. Insert on one side first and pull down with a gentle tug, followed by the opposite side.

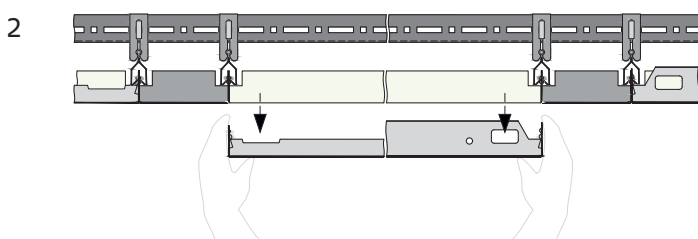

Remove it downwards and store the tile/panel in a safe place so that it cannot be damaged. If you wish to gain access to the plenum, try to access it through the tiles/panels whenever possible. The crossing boxes and strips can also be removed if necessary. Be especially careful with the strips, as these can be damaged quickly, especially with long runs.

METAL K-Clip

D02.103

Detail L

Optional security clip

The security clip serves to secure the tiles/panels and prevents them from being removed.

Tile/panel locking

METAL Q-Clip

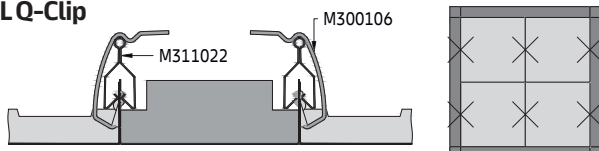

The tiles/panels have, on the sides where the pips are, an embossing where the security clip can be fixed. First hook the security clip into the tile/panel and then slip the upper end over the DP12 A-Bar. Two security clips are required per tile/panel.

METAL R-Clip

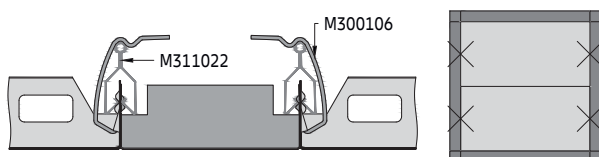

Either individual tiles/panels or the entire ceiling can be secured. The tiles/panels are inserted and secured immediately. The last tile/panel cannot be locked, same as crossing boxes and strips. On request, the crossing boxes and strips can also be designed with an embossing for security clips.

Material required per m² (no waste included) System without additional load [pcs/m²]

Components		a2 [mm]	700	725	1000	1300	1350	1600	1900	2025
M300100	U-Profile		0.15	0.16	0.18	0.21	0.21	0.22	0.28	0.26
M300105	Hanger for DP12 A-Bar		1.64	1.68	1.34	1.2/1.8*	1.14/1.71*	1.06	1.12/1.68*	1.44
M300119	Splice connector for U-Profile		0.16	0.14	0.18	0.21	0.21	0.23	0.28	0.10
M300120	Plug-in clip for U-Profile		2.28	2.36	2.06	2.04/3.06*	1.88/2.82*	1.88	2.28/3.42*	0.39
M300138	Connection pin for DP12 A-Bar		0.72	0.70	0.50	0.4/0.6*	0.38/0.57*	0.32	0.28/0.42*	0.39
M300140	Wall anchor		0.06	0.07	0.07	0.08	0.08	0.09	0.11	0.10
M311022	DP12 A-Bar		0.72	0.79	0.50	0.38/0.57*	0.37/0.56*	0.31	0.26/0.39*	0.37
M311103	Hexagonal nut M6		0.10	0.10	0.10	0.10	0.10	0.10	0.10	0.10
M311105	Washer		0.10	0.10	0.10	0.10	0.10	0.10	0.10	0.10
M311303	Hexagonal bolt M6 x 16 mm		0.10	0.10	0.10	0.10	0.10	0.10	0.10	0.10
Various	Suspension points (E1 - E4)		0.41	0.42	0.67	0.60	0.58	0.53	0.56	0.95

The shown quantities are theoretical and based on an ideal layout, without considering the actual room layout. The ideal layout is based on a calculation of 10 x 10 m (100 m²). This calculation does not allow any damage, spare nor wastage. The final quantities and type of suspension have to be checked before ordering. Soffit and wall fixings by others.

* values for modules with METAL R-Clip / METAL Q-Clip

Not including perimeter trims and extraction tools.



METAL Q-Clip F
Zürich Train Station, Passage Sihlquai, Exit Europallee, Switzerland
© Foto Lautenschlager

METAL K-Clip

DP12 A-Bar primary grid + DP12 A-Bar secondary grid
Concealed grid solution for indoor applications

General information

- Concealed clip-in tartan grid system for large rooms
- Layouts with METAL Q-Clip tiles or METAL R-Clip panels in combination with crossing boxes and strips
- For perpendicular installation on DP12 A-Bar primary grid
- DP12 A-Bar made of galvanised steel
- Crossing box and strips in RAL 9010 made of galvanised steel (further sizes, cut-outs and colour options on request)
- Typical ceiling weight 6.0 kg/m² (with METAL Q-Clip), 7.0 kg/m² (with METAL R-Clip) (indicative value for unperforated tiles / panels, without additional load)
- Tiles / panels are easily installed and fully demountable
- Optional security clips available for tiles / panels

Isometric view

Select the suspension option D1 - D2.
Perimeter solutions on separate datasheet.

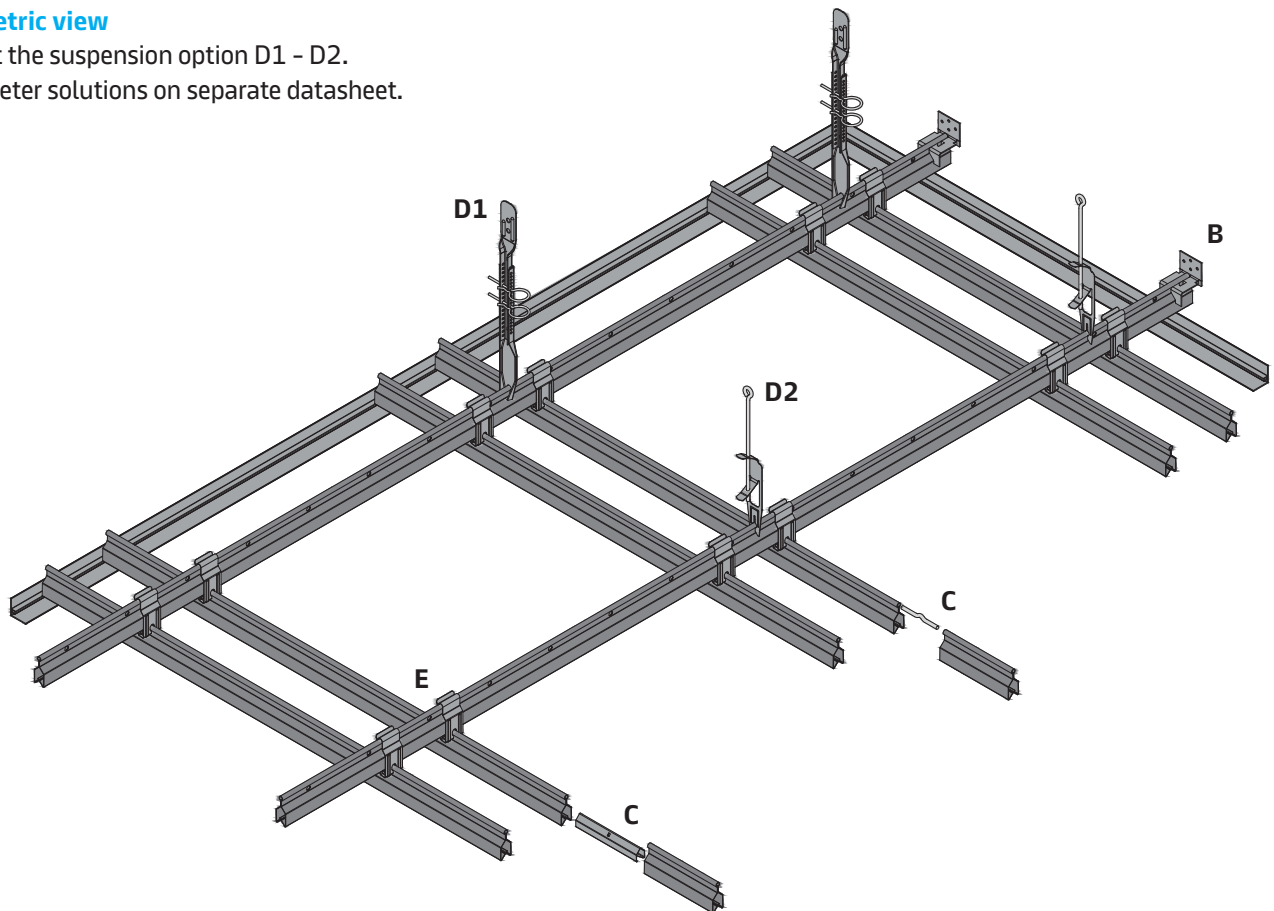

METAL K-Clip

D02.103.1

Standard, Vario Design layout options

Standard with METAL Q-Clip tiles

Vario Design with METAL R-Clip tiles

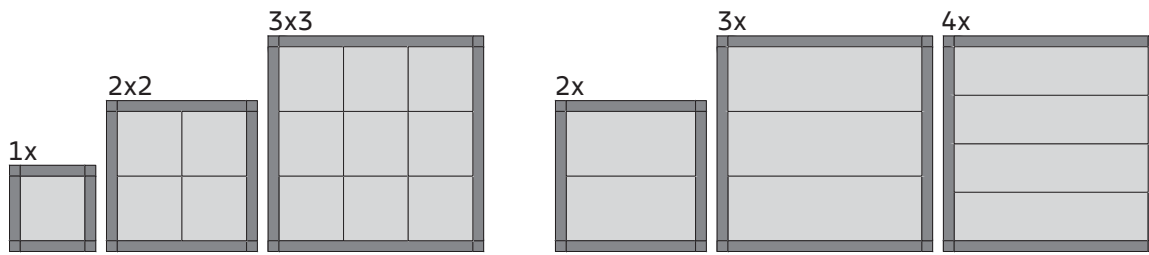

Section F (with 1x METAL Q-Clip)

Example with suspension option D2

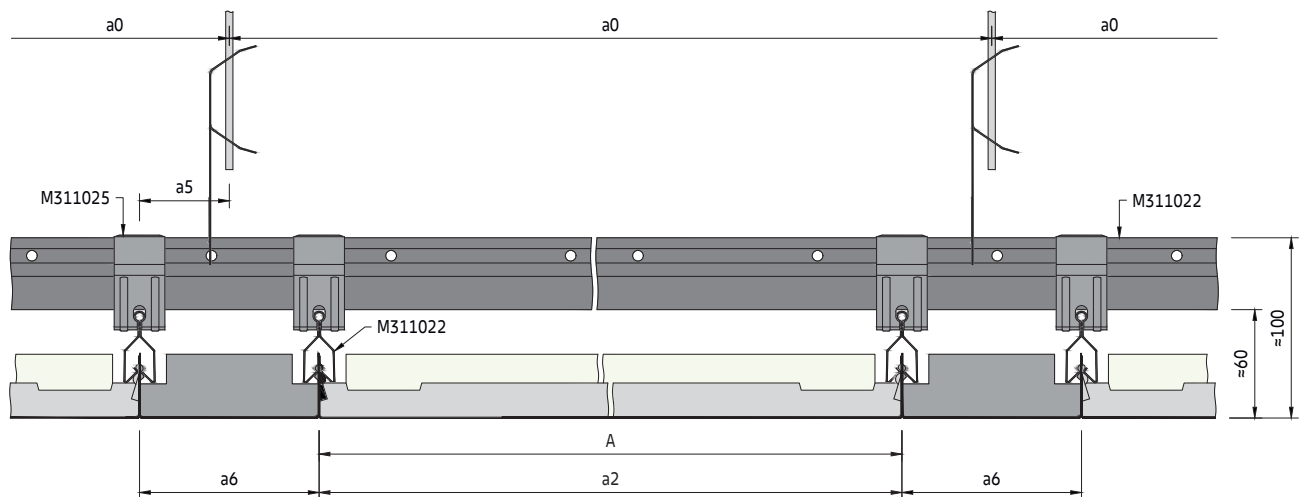

Section F (with METAL R-Clip)

Example with suspension option D2

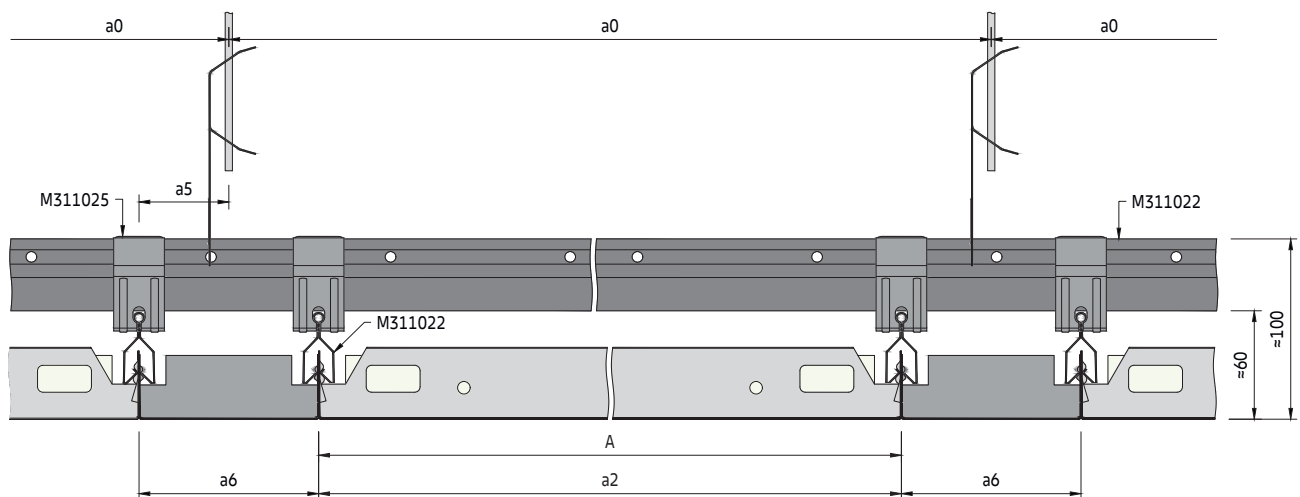

METAL K-Clip

D02.103.1

Secondary grid components

Standard components

- M311022 DP12 A-Bar
- M300138 Connection pin for DP12 A-Bar
- M311025 Cross connector for DP12 A-Bar

Optional components

- M300106 Security clip
- M311023 Splice connector for DP12 A-Bar
- M311028 Extraction tool

See DP12 A-Bar primary grid for primary grid components

DP12 A-Bar secondary grid

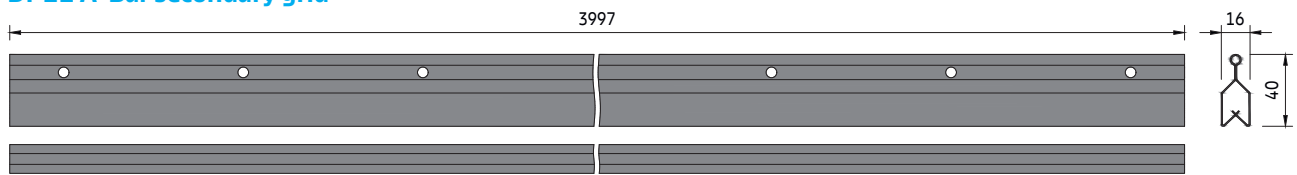

Section G (with 1x METAL Q-Clip)

Example with suspension option D2

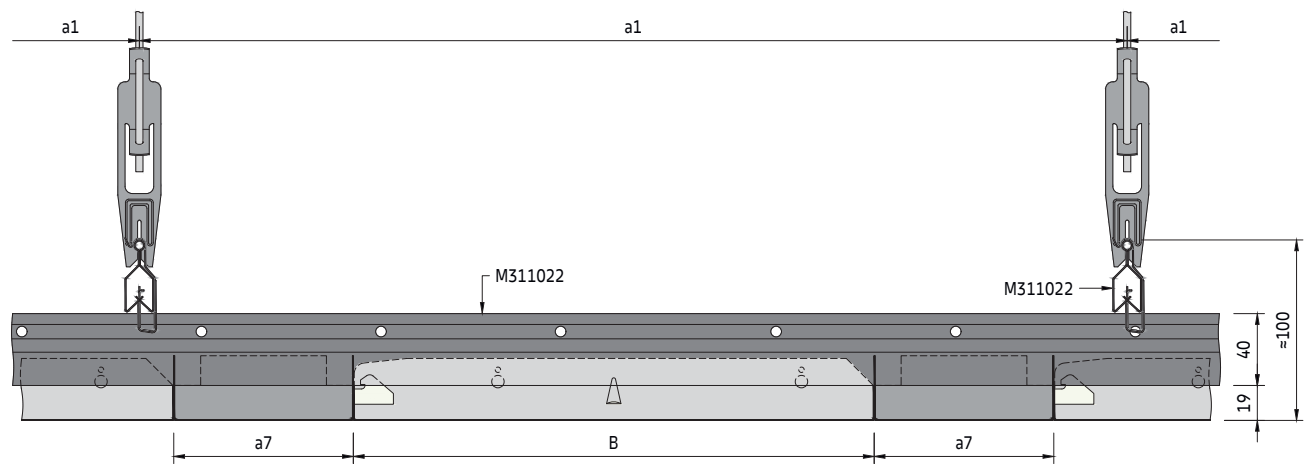

Section G (with METAL R-Clip)

Example with suspension option D2

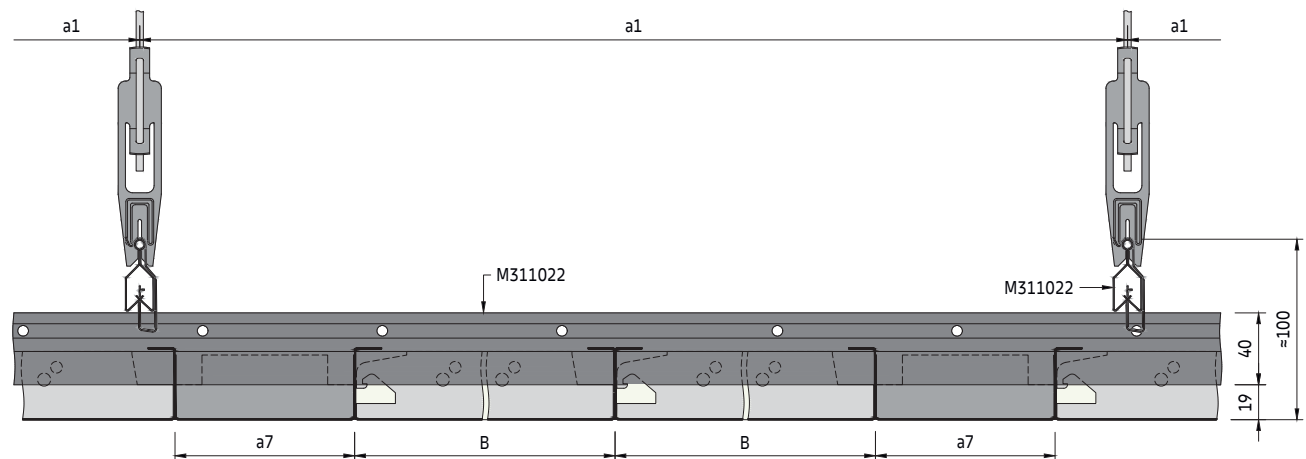

Spacing

Module [mm]	System without additional load		System with additional load +4 kg/m ²		System with additional load +6 kg/m ²	
	a0 [mm]	a1 [mm]	a0 [mm]	a1 [mm]	a0 [mm]	a1 [mm]
700	1400	1450	1400	950	1400	750
725	1450	1300	1450	850	1450	700
750	1500	1300	750	1550	750	1500
775	1550	1100	775	1600	775	1500
1300	1300	1600	1300	1150	1300	900
1325	1325	1550	1325	1150	1325	850
1350	1350	1550	1350	1150	1350	800
1375	1375	1550	1375	1000	1375	800
1400	1400	1550	1400	1000	1400	750
1450	1450	1450	1450	900	1450	700
1500	1500	1350	1500	850	1500	650
1550	1550	1250	1550	800	1550	600
1600	1600	1200	1600	750	800	1150
1650	1650	1100	1650	700	825	1150
1700	1700	1050	1700	650	850	1150
1750	1750	950	1750	600	875	1150
1800	1800	850	1800	550	900	1150
1850	1850	800	1850	500	925	1100
1900	1900	700	1900	450	950	1100
1925	963	1400	963	1200	963	1100
1950	975	1400	975	1200	975	1100
1975	988	1400	988	1200	988	1100
2000	1000	1400	1000	1200	1000	1100
2025	1013	1400	1013	1200	1013	1100

Parameters

- a0 Distance between DP12 A-Bar suspension points = max. 1900 mm
- a1 Max. distance between DP12 A-Bars
- a2 Distance between DP12 A-Bars = tile / panel length
- a3 Distance from wall = max. 200 mm
- a4 Distance from wall = max. tile / panel length
- a5 Distance from DP12 A-Bar suspension point to hanger = max. 100 mm
- a6 Crossing box length (X) / strip width (Y) = 100, 125, 150 mm
- a7 Crossing box width (Y) / strip width (Y) = 100, 125, 150 mm
- M Module length = tile / panel length + strip width
Module width = tile / panel width (2, 3 or 4x) + strip width

METAL Q-Clip

M 600 x 600, 625 x 625 mm

METAL R-Clip

- A Panel length = min. 600 / max. 1800 mm
- B Panel width = min. 250 / max. 600 mm

Typical grid layout

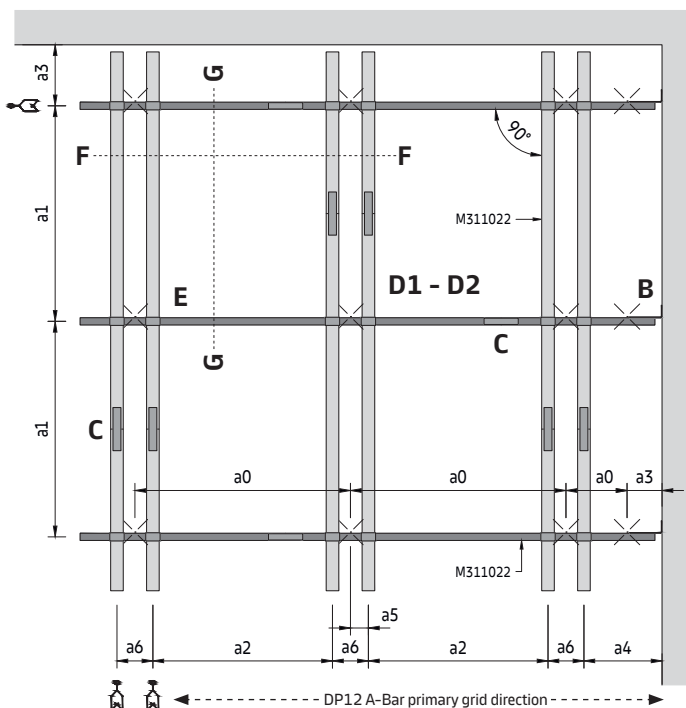

To determine suspension layout

The module length (M) of the requested ceiling is equal to the distance between the DP12 A-Bar centres (a2).

On the appropriate spacing table, read down the column headed (a2) to the required module length then read across to determine the suspension point spacing (a0) and DP12 A-Bar spacing (a1).

The shown values are maximum allowed distances and can be reduced but not exceeded.

METAL K-Clip

D02.103.1

Section H (with 2x2 METAL Q-Clip)

Example with suspension option D2

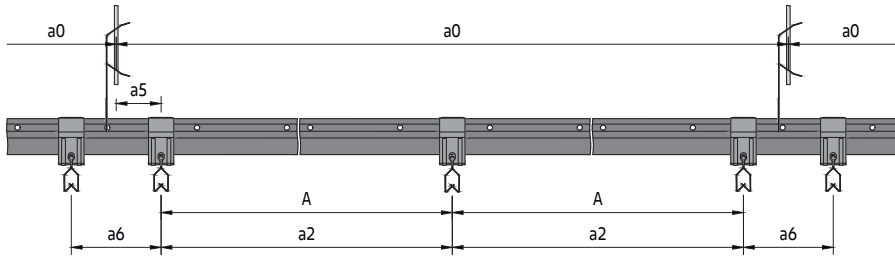

Section H (with 3x3 METAL Q-Clip)

Example with suspension option D2

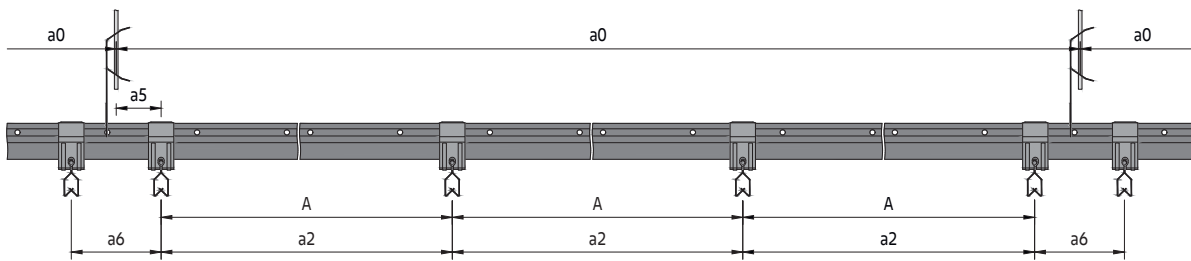

Section H (with 3x3 METAL Q-Clip)

Example with suspension option D2 module > 1900 mm

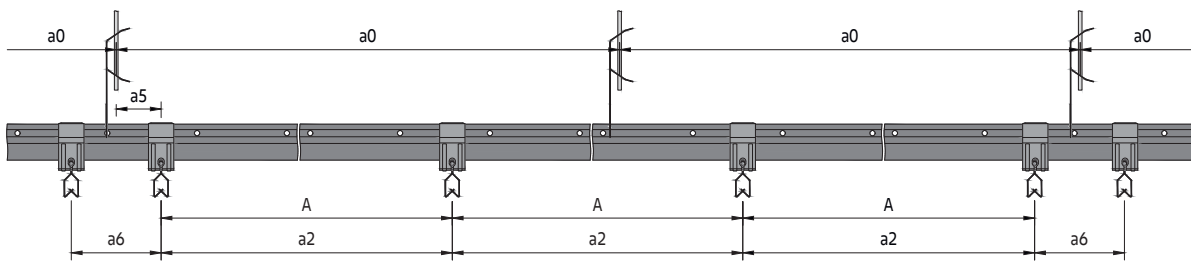

METAL K-Clip
D02.103.1

Spacing

a2 [mm]	System without additional load		System with additional load +4 kg/m ²		System with additional load +6 kg/m ²	
	a0 [mm]	a1 [mm]	a0 [mm]	a1 [mm]	a0 [mm]	a1 [mm]
700	1400	1750	1400	1250	1400	1000
725	1450	1750	1450	1250	1450	900
750	1500	1650	750	1550	750	1500
775	1550	1550	775	1550	775	1500
1300	1300	1300	1300	1200	1300	1150
1325	1325	1300	1325	1200	1325	1100
1350	1350	1300	1350	1150	1350	1050
1375	1375	1300	1375	1150	1375	1000
1400	1400	1300	1400	1150	1400	1000
1450	1450	1250	1450	1100	1450	900
1500	1500	1250	1500	1100	1500	850
1550	1550	1200	1550	1050	1550	800
1600	1600	1200	1600	1000	1600	750
1650	1650	1200	1650	900	1650	700
1700	1700	1150	1700	850	1700	650
1750	1750	1150	1750	800	1750	600
1800	1800	1100	1800	700	900	1150
1850	1850	1000	1850	650	925	1100
1900	1900	950	1900	600	950	1100
1925	963	1100	963	950	963	1100
1950	975	1100	975	950	975	1100
1975	988	1050	988	950	988	1100
2000	1000	1050	1000	950	1000	1100
2025	1013	1050	1013	950	1013	1100

To determine suspension layout

The module length (M) of the requested ceiling is equal to the distance between the DP12 A-Bar centres (a2).

On the appropriate spacing table, read down the column headed (a2) to the required module length then read across to determine the suspension point spacing (a0) and U-Profile spacing (a1).

The shown values are maximum allowed distances and can be reduced but not exceeded.

Parameters

- a0 Distance between DP12 A-Bar suspension points = max. 1900 mm
- a1 Max. distance between DP12 A-Bars
- a2 Distance between DP12 A-Bars = tile length
- a3 Distance from wall = max. 200 mm
- a4 Distance from wall = max. tile length
- a5 Distance from DP12 A-Bar suspension point to hanger = max. 100 mm
- a6 Crossing box length (X) / strip width (Y) = 100, 125, 150 mm
- a7 Crossing box width (Y) / strip width (Y) = 100, 125, 150 mm
- M Module length = tile length (2 or 3x) + strip width
Module width = tile width (2 or 3x) + strip width

METAL Q-Clip

M 600 x 600, 625 x 625 mm

Typical grid layout

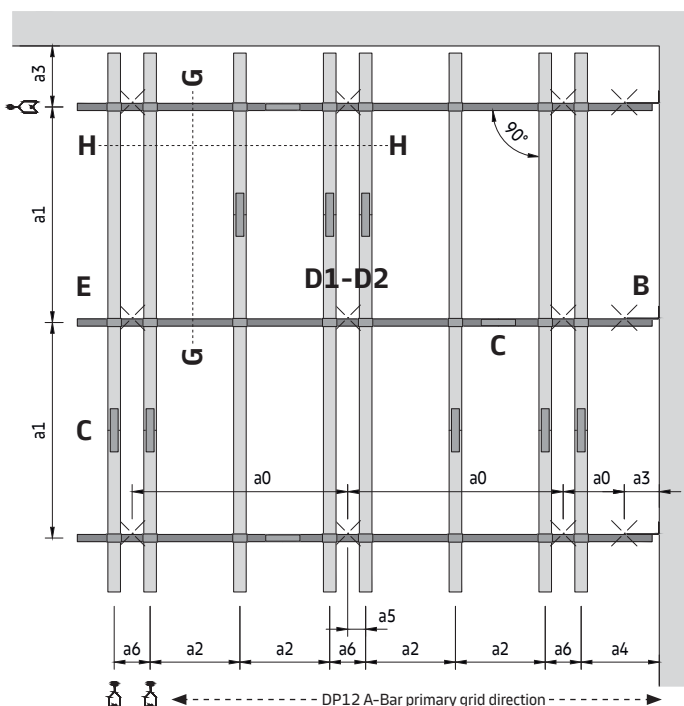

METAL K-Clip

D02.103.1

Crossing box & strips

Option with 1x METAL Q-Clip / METAL R-Clip

Crossing box

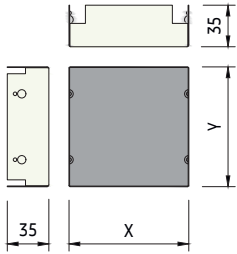

Strip (for 1x METAL Q-Clip)

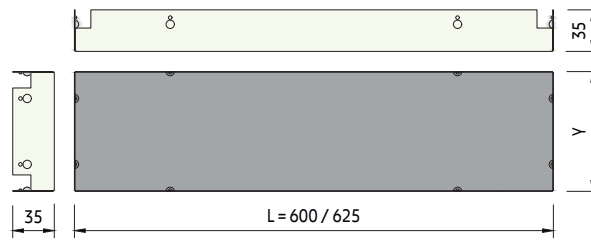

The strips are delivered with pips on all four sides. This allows the same strip to be installed lengthwise and crosswise.

Strip (for METAL R-Clip)

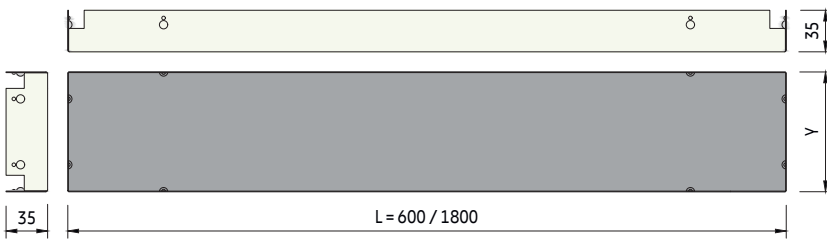

Option with 2x2 or 3x3 METAL Q-Clip

Crossing box

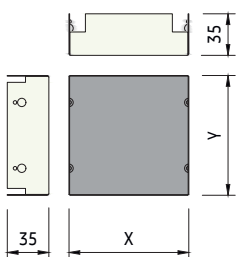

Strip (for 2x2 METAL Q-Clip)

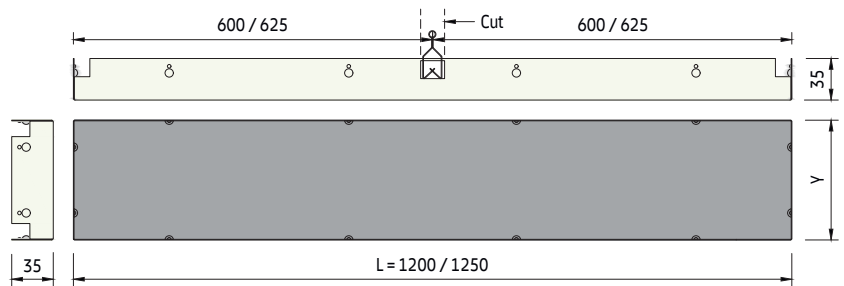

The strips are delivered with pips on all four sides. This allows the same strip to be installed lengthwise and crosswise. There are notches on the long sides that are cut away on site to allow the DP12 A-Bar to pass through.

Strip (for 3x3 METAL Q-Clip)

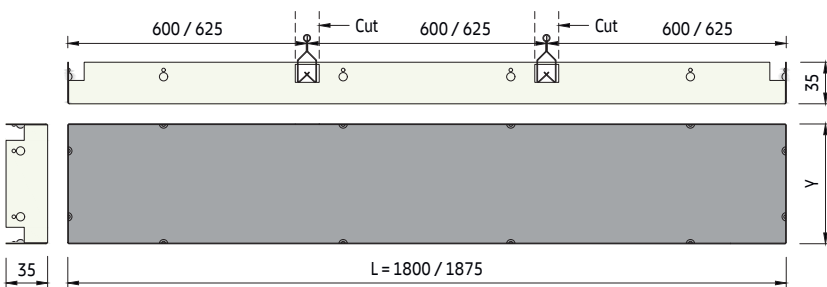

METAL K-Clip

D02.103.1

Detail E

Cross connector installation

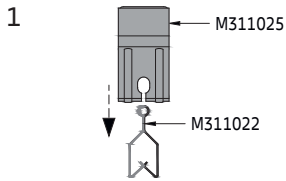

The cross connector is inserted from the end of the DP12 A-Bar secondary grid. Then it can be slid to the correct position.

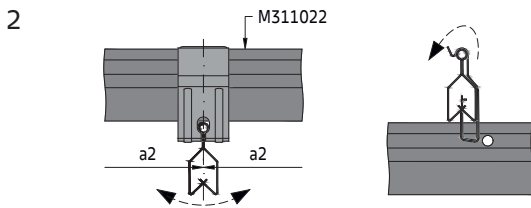

The cross connector for DP12 A-Bar is made of spring steel and is therefore elastic. It is hooked on the DP12 A-Bar primary grid. The DP12 A-Bar secondary grid is now locked in position. Due to the round head of the DP12 A-Bar, it can swing. This is important because it allows any tolerances to be compensated. Otherwise the tiles/panels will no longer be inserted after a certain point.

Detail C

Splice connection

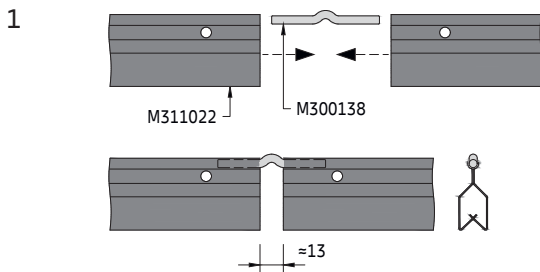

Insert the connection pin at the ends of the DP12 A-Bars and connect them. There is a gap between the DP12 A-Bars. The DP12 A-Bars must be aligned so that the joint is not in the same place as the pips on the tiles/panels.

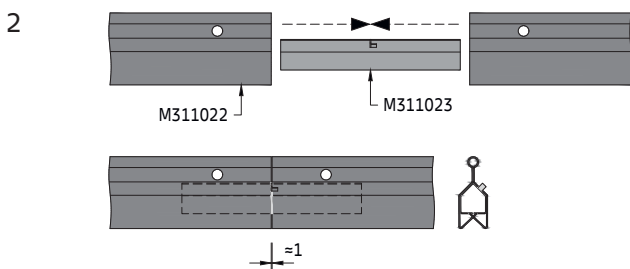

Optionally, the splice connector for DP12 A-Bar can be used. This is inserted at the ends of the DP12 A-Bars and an almost seamless connection is created.

METAL K-Clip

D02.103.1

Detail I

Tile / panel insertion

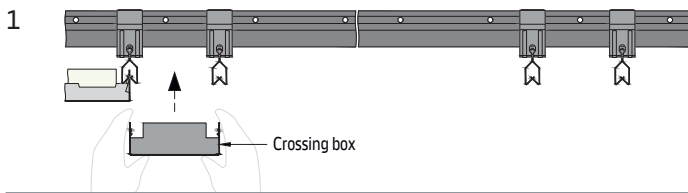

The components are installed continuously. Take the crossing box and insert into the DP12 A-Bars from below. The crossing box has pips on two sides, so it must always be laid in the same direction. The upper pip is clamped into the DP12 A-Bar.

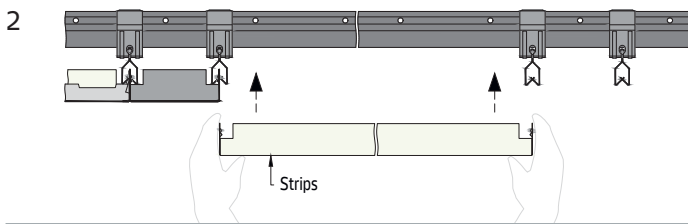

The strips feature pips on all four sides. This allows them to be inserted lengthwise and crosswise into the DP12 A-Bar.

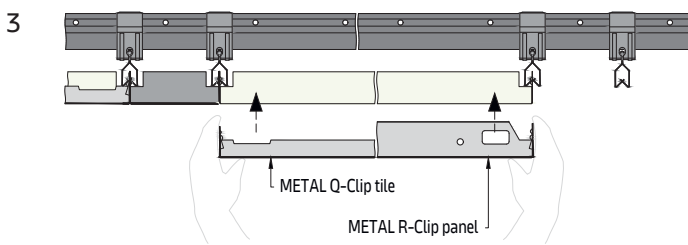

Take the tile / panel and carefully insert it into the DP12 A-Bars from below. All tiles / panels feature a double row of pips. The upper pip is inserted into the DP12 A-Bar, the lower one serves as a stop. Be careful with the tiles. Always press along the edges with the pips and never on the transverse sides, otherwise the tile may be damaged. The tiles / panels should always be laid in such a way that the WINDOW hooks point in the same direction.

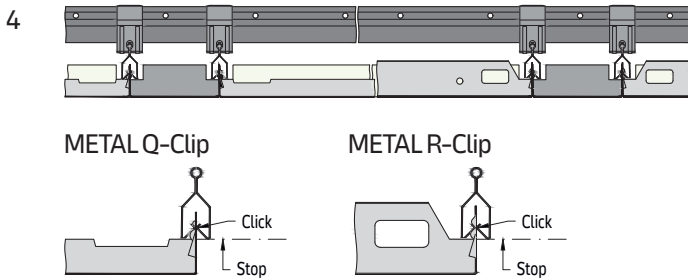

The tiles / panels are correctly inserted when all four corners are flush with the neighboring tiles / panels. The tiles / panels are designed to match the DP12 A-Bar. When using third-party profiles, there is a high probability that this is not the case.

Tile / panel extraction

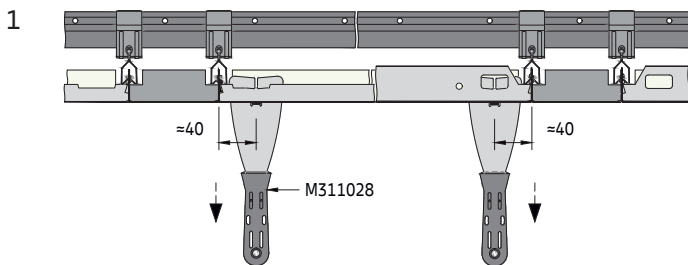

The tiles / panels are designed in such a way that the extraction tool can only be inserted in the designated places so that it clicks into place. There is an indentation on the tiles for this purpose, and a rectangular cut-out on the panels. It is therefore important that the right extraction tool is used. This prevents damage to the tiles / panels. Insert on one side first and pull down with a gentle tug, followed by the opposite side.

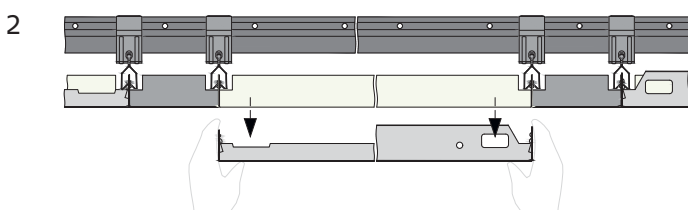

Remove it downwards and store the tile / panel in a safe place so that it cannot be damaged. If you wish to gain access to the plenum, try to access it through the tiles / panels whenever possible. The crossing boxes and strips can also be removed if necessary. Be especially careful with the strips, as these can be damaged easily, especially with long runs.

METAL K-Clip

D02.103.1

Detail J**Optional security clip**

The security clip serves to secure the tiles / panels and prevents them from being removed.

Tile / panel locking

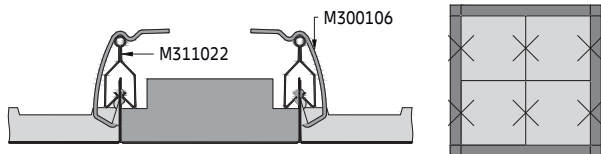
METAL Q-Clip

The tiles / panels have, on the sides where the pips are, an embossing where the security clip can be fixed. First hook the security clip into the tile / panel and then slip the upper end over the DP12 A-Bar. Two security clips are required per tile / panel.

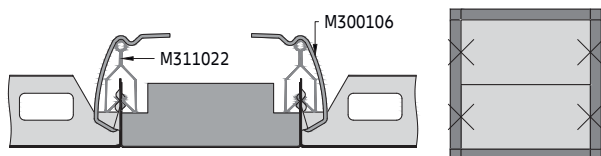
METAL R-Clip

Either individual tiles / panels or the entire ceiling can be secured. The tiles / panels are inserted and secured immediately. The last tile / panel cannot be locked, same as crossing boxes and strips. On request, the crossing boxes and strips can also be designed with an embossing for security clips.

Material required per m² (no waste included)**System without additional load [pcs/m²]**

Components		a2 [mm]	700	725	1000	1300	1350	1600	1900	2025
M300138	Connection pin for DP12 A-Bar		0.89	0.86	0.65	0.40/0.73*	0.53/0.72*	0.52	0.62/0.75*	0.42
M311022	DP12 A-Bar		0.89	0.86	0.65	0.40/0.73*	0.53/0.72*	0.52	0.62/0.75*	0.42
M311024	Wall anchor for DP12 A-Bar		0.07	0.08	0.06	0.07	0.07	0.09	0.15	0.08
M311025	Cross connector for DP12 A-Bar		0.98	1.06	1.18	0.96/1.44*	0.96/1.44*	1.04	1.50/2.25*	1.42
Various	Suspension points (D1 - D2)		0.49	0.53	0.59	0.48	0.48	0.52	0.75	0.71

The shown quantities are theoretical and based on an ideal layout, without considering the actual room layout. The ideal layout is based on a calculation of 10 x 10 m (100 m²). This calculation does not allow any damage, spare nor wastage. The final quantities and type of suspension have to be checked before ordering. Soffit and wall fixings by others.

* values for modules with METAL R-Clip / METAL Q-Clip

Not including perimeter trims and extraction tools.

METAL K-Clip

Direct suspended DP12 A-Bar
Concealed grid solution for indoor applications

General information

- Concealed clip-in tartan grid system for small areas with low cavity
- Layouts with METAL Q-Clip tiles or METAL R-Clip panels in combination with crossing boxes and strips
- DP12 A-Bar made of galvanised steel
- Crossing box and strips in RAL 9010 made of galvanised steel (further sizes, cut-outs and colour options on request)
- Typical ceiling weight 5.5 kg/m² (with METAL Q-Clip), 6.5 kg/m² (with METAL R-Clip) (indicative value for unperforated tiles / panels, without additional load)
- Tiles / panels are easily installed and fully demountable
- Optional security clips available for tiles / panels

Isometric view

Perimeter solutions on separate datasheet.

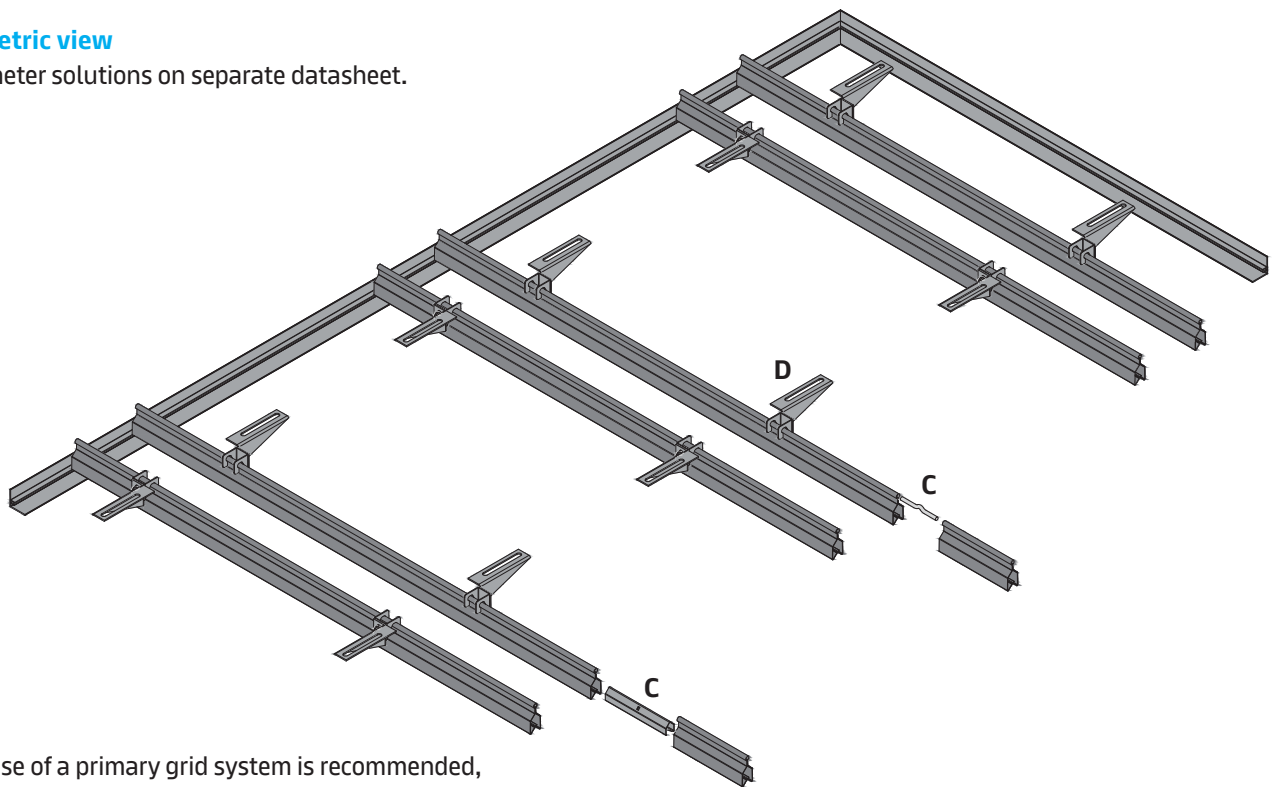

The use of a primary grid system is recommended, as this simplifies levelling and the alignment of the ceiling.

Standard, Vario Design layout options

Standard with METAL Q-Clip tiles

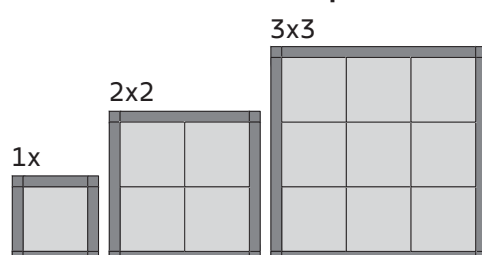

Vario Design with METAL R-Clip tiles

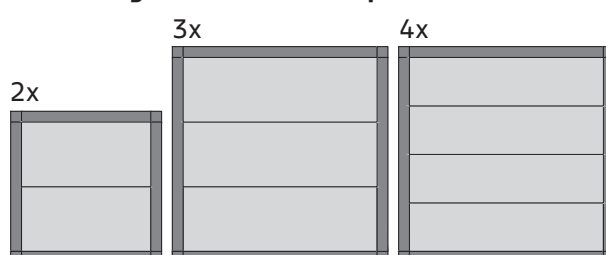

METAL K-Clip

D02.103.2

Section A (with 1x METAL Q-Clip)

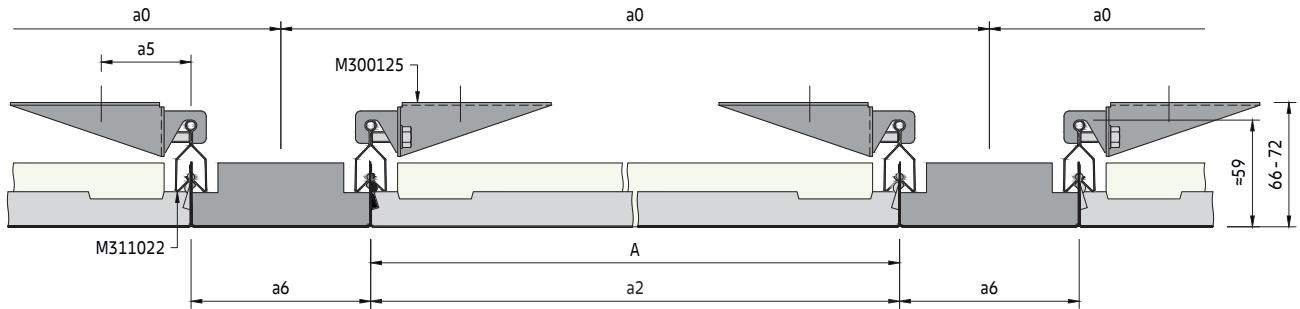

Section A (with METAL R-Clip)

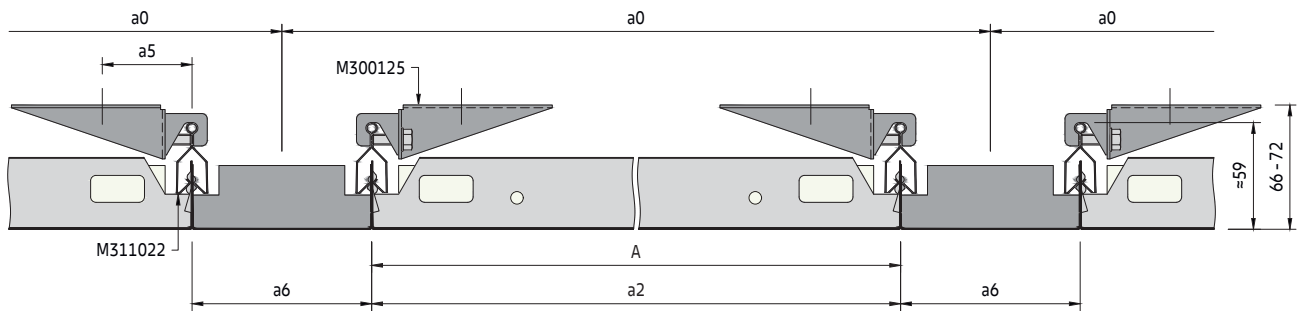

Secondary grid components

Standard components

- M311022 DP12 A-Bar
- M300138 Connection pin for DP12 A-Bar
- M300105 Hanger for DP12 A-Bar

Optional components

- M300106 Security clip
- M311023 Splice connector for DP12 A-Bar
- M311028 Extraction tool

See DP12 A-Bar primary grid for primary grid components

DP12 A-Bar

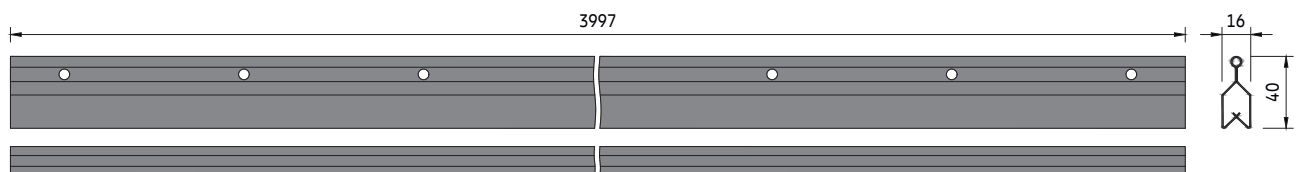

METAL K-Clip

D02.103.2

Section B (with 1x METAL Q-Clip)

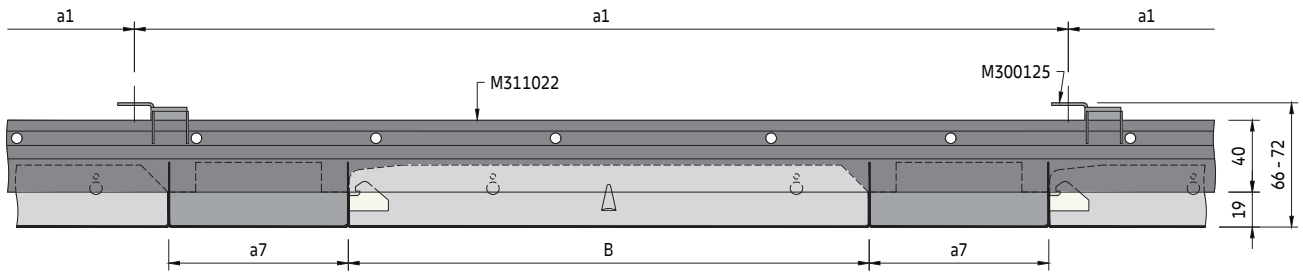

Section B (with METAL R-Clip)

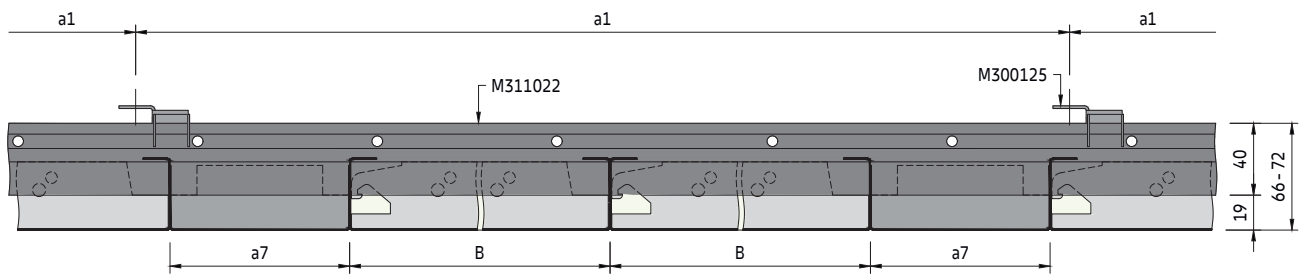

Section A (with 2x2 METAL Q-Clip)

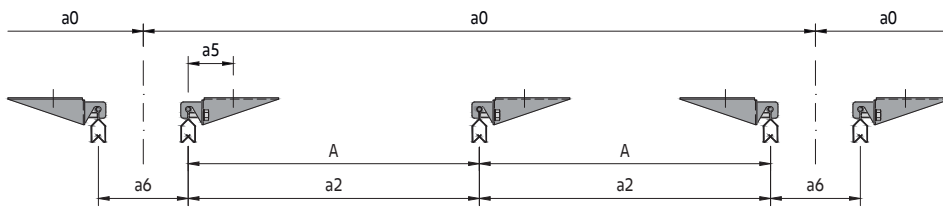

Section A (with 3x3 METAL Q-Clip)

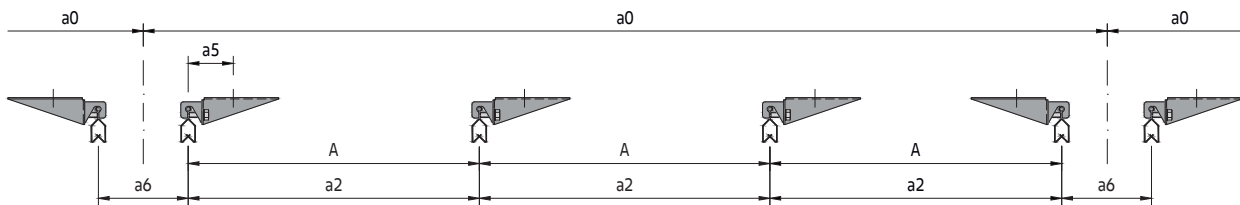

METAL K-Clip
D02.103.2

Spacing for modules with METAL Q-Clip

Module [mm]	System without additional load		System with additional load +4 kg/m ²		System with additional load +6 kg/m ²	
	a0 [mm]	a1 [mm]	a0 [mm]	a1 [mm]	a0 [mm]	a1 [mm]
700	700	1500	700	1500	700	1500
725	725	1500	725	1500	725	1500
750	750	1500	750	1500	750	1500
775	775	1500	775	1500	775	1500
1300	1300	1500	1300	1500	1300	1200
1325	1325	1500	1325	1500	1325	1200
1350	1350	1500	1350	1500	1350	1200
1375	1375	1500	1375	1500	1375	1200
1900	1900	1500	1900	1500	1900	1000
1925	1925	1500	1925	1500	1925	1000
1950	1950	1500	1950	1500	1950	1000
1975	1975	1500	1975	1500	1975	1000
2000	2000	1500	2000	1500	2000	1000
2025	2025	1500	2025	1500	2025	1000

Spacing for modules with METAL R-Clip

Module [mm]	System without additional load		System with additional load +4 kg/m ²		System with additional load +6 kg/m ²	
	a0 [mm]	a1 [mm]	a0 [mm]	a1 [mm]	a0 [mm]	a1 [mm]
700	700	1500	700	1500	700	1500
750	750	1500	750	1500	750	1500
800	800	1500	800	1500	800	1500
850	850	1500	850	1500	850	1500
900	900	1500	900	1500	900	1500
950	950	1500	950	1500	950	1200
1000	1000	1500	1000	1200	1000	1000
1050	1050	1500	1050	1200	1050	1000
1100	1100	1500	1100	1200	1100	1000
1050	1050	1500	1050	1200	1050	1000
1100	1100	1500	1100	1200	1100	1000
1150	1150	1500	1150	1200	1150	1000
1200	1200	1500	1200	1200	1200	1000
1250	1250	1500	1250	1200	1250	1000
1300	1300	1200	1300	1200	1300	1000
1350	1350	1200	1350	1000	1350	800
1400	1400	1200	1400	1000	1400	800
1450	1450	1200	1450	1000	1450	800
1500	1500	1200	1500	1000	1500	800
1550	1550	1200	1550	1000	1550	800
1600	1600	1200	1600	1000	1600	800
1650	1650	1200	1650	800	1650	600
1700	1700	1000	1700	800	1700	600
1750	1750	1000	1750	800	1750	600
1800	1800	1000	1800	600	1800	500
1850	1850	1000	1850	600	1850	500
1900	1900	800	1900	600	1900	500
1950	1950	800	1950	600	1950	500

Parameters

- a0 Distance between module centres
- a1 Max. distance between direct hangers
- a2 Distance between DP12 A-Bars = tile / panel length
- a3 Distance from wall = max. 200 mm
- a4 Distance from wall = max. tile / panel length
- a5 Distance between DP12 A-Bar and top fixing = 38 - 50 mm
- a6 Crossing box length (X) / strip width (Y) = 100, 125, 150 mm
- a7 Crossing box width (Y) / strip width (Y) = 100, 125, 150 mm
- M Module length = tile / panel length + strip width
Module width = tile / panel width (2, 3 or 4x) + strip width

METAL Q-Clip

M 600 x 600, 625 x 625 mm

METAL R-Clip

- A Panel length = min. 600 / max. 1800 mm
- B Panel width = min. 250 / max. 600 mm

Typical grid layout

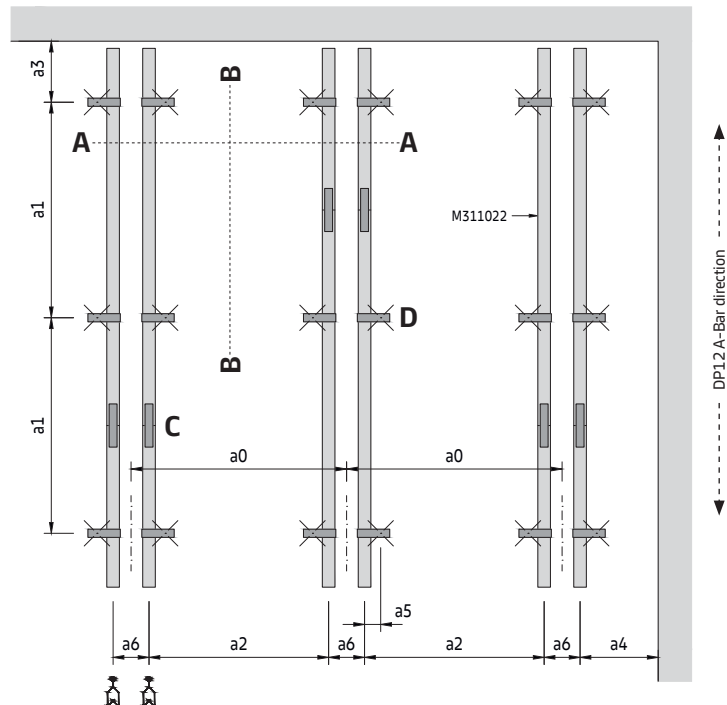

To determine suspension layout

The module length (M) of the requested ceiling is equal to the distance between the DP12 A-Bar centres (a2). On the appropriate spacing table, read down the column headed (a2) to the required module length then read across to determine the suspension point spacing (a0) and direct hanger spacing (a1). The shown values are maximum allowed distances and can be reduced but not exceeded.

METAL K-Clip

D02.103.2

Crossing box & strips

Option with 1x METAL Q-Clip / METAL R-Clip

Crossing box

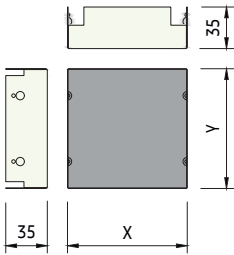

Strip (for 1x METAL Q-Clip)

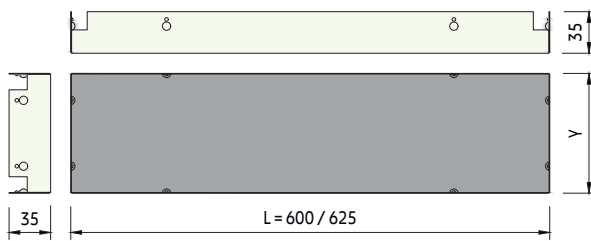

Strip (for METAL R-Clip)

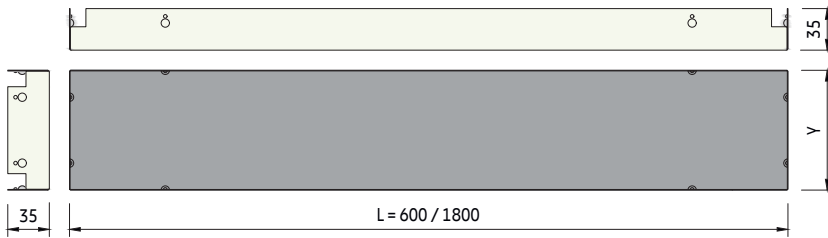

The strips are delivered with pips on all four sides. This allows the same strip to be installed lengthwise and crosswise.

Option with 2x2 or 3x3 METAL Q-Clip

Crossing box

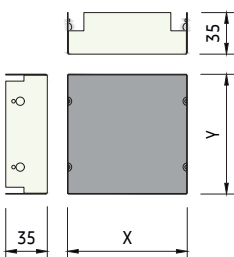

Strip (for 2x2 METAL Q-Clip)

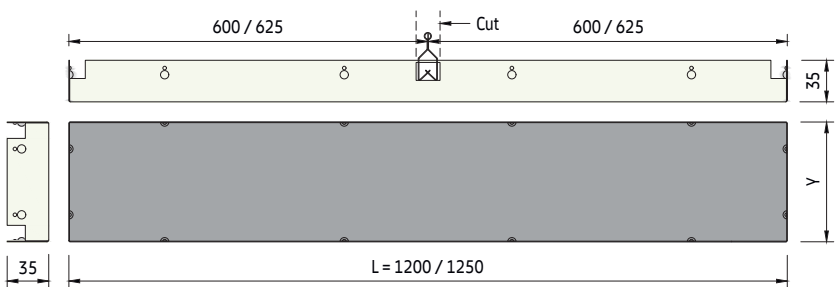

Strip (for 3x3 METAL Q-Clip)

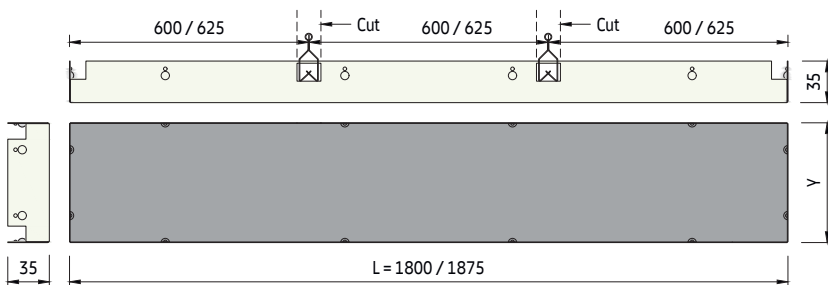

The strips are delivered with pips on all four sides. This allows the same strip to be installed lengthwise and crosswise. There are notches on the long sides that are cut away on site to allow the DP12 A-Bar to pass through.

METAL K-Clip

D02.103.2

Detail C

Splice connection

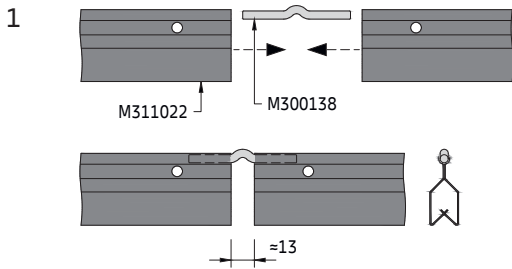

Insert the connection pin at the ends of the DP12 A-Bars and connect them. There is a gap between the DP12 A-Bars. The DP12 A-Bars must be aligned so that the joint is not in the same place as the pips on the tiles / panels.

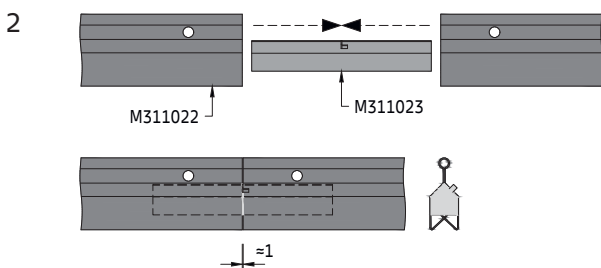

Optionally, the splice connector for DP12 A-Bar can be used. This is inserted at the ends of the DP12 A-Bars and an almost seamless connection is created.

Detail D

Direct hanger installation

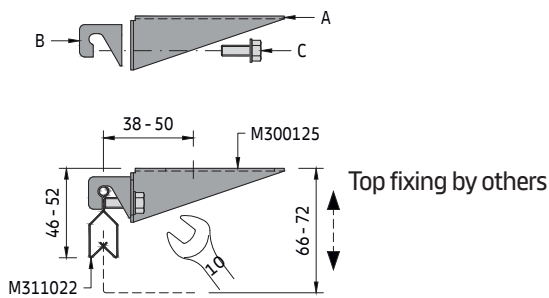

The direct hanger consists of three pre-assembled components (A, B, C).

Depending on the width of the crossing boxes, the direct hangers must either be offset or positioned alternately (left / right).

Part A is attached to the soffit first. The distance from the DP12 A-Bar to the attachment point must not exceed 50 mm.

Part B is not tightened, so the DP12 A-Bar can be inserted from below. Tightening the bolt (part C) creates a stable connection.

Before that, the height should be set up.

Optional installation

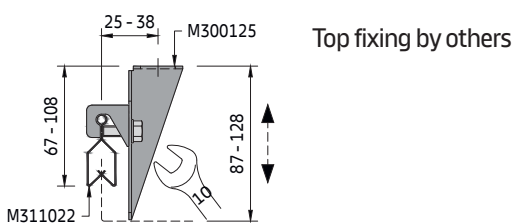

The distance between the DP12 A-Bars should be measured exactly, otherwise the tiles / panels are difficult to install and elements could fall out.

The direct hanger can optionally also be installed vertically. To do this, the components must first be disassembled. The shorter side of part A is then attached to the soffit.

METAL K-Clip

D02.103.2

Detail E

Tile / panel insertion

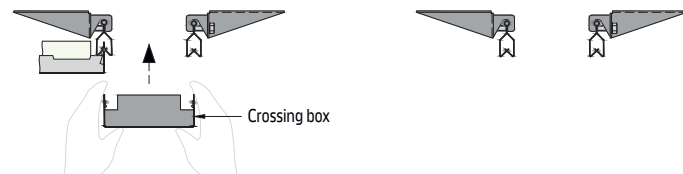
1  The components are installed continuously. Take the crossing box and insert into the DP12 A-Bars from below. The crossing box has pips on two sides, so it must always be laid in the same direction. The upper pip is clamped into the DP12 A-Bar.

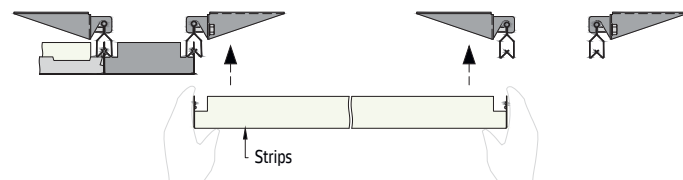
2  The strips feature pips on all four sides. This allows them to be inserted lengthwise and crosswise into the DP12 A-Bar.

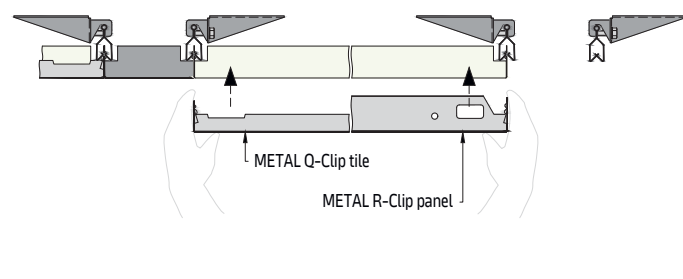
3  Take the tile / panel and carefully insert it into the DP12 A-Bars from below. All tiles / panels feature a double row of pips. The upper pip is inserted into the DP12 A-Bar, the lower one serves as a stop. Be careful with the tiles. Always press along the edges with the pips and never on the transverse sides, otherwise the tile may be damaged. The tiles / panels should always be laid in such a way that the WINDOW hooks point in the same direction.

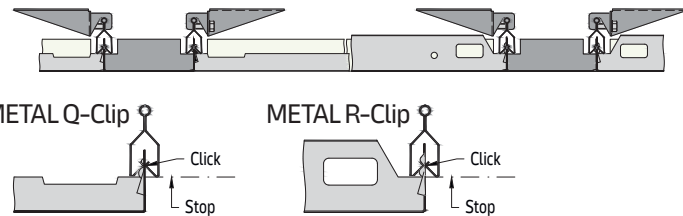
4  The tiles / panels are correctly inserted when all four corners are flush with the neighboring tiles / panels. The tiles / panels are designed to match the DP12 A-Bar. When using third-party profiles, there is a high probability that this is not the case.

Tile / panel extraction

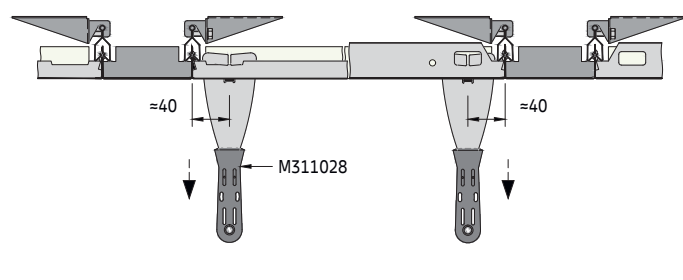
1  The tiles / panels are designed in such a way that the extraction tool can only be inserted in the designated places so that it clicks into place. There is an indentation on the tiles for this purpose, and a rectangular cut-out on the panels. It is therefore important that the right extraction tool is used. This prevents damage to the tiles / panels. Insert on one side first and pull down with a gentle tug, followed by the opposite side.

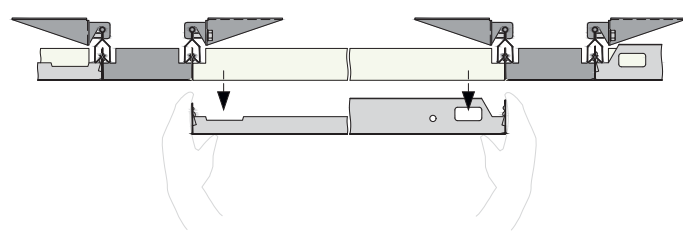
2  Remove it downwards and store the tile / panel in a safe place so that it cannot be damaged. If you wish to gain access to the plenum, try to access it through the tiles / panels whenever possible. The crossing boxes and strips can also be removed if necessary. Be especially careful with the strips, as these can be damaged easily, especially with long runs.

METAL K-Clip
D02.103.2

Detail F

Optional security clip

The security clip serves to secure the tiles / panels and prevents them from being removed.

Tile / panel locking

METAL Q-Clip

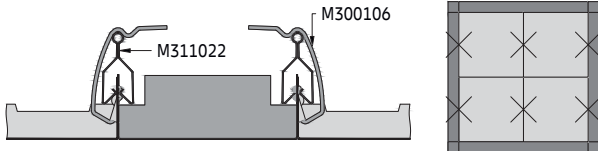

The tiles / panels have, on the sides where the pips are, an embossing where the security clip can be fixed. First hook the security clip into the tile / panel and then slip the upper end over the DP12 A-Bar. Two security clips are required per tile / panel.

Due to the small distance to the soffit, installing the security clips could be more difficult

METAL R-Clip

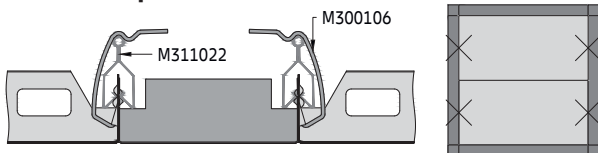

Either individual tiles / panels or the entire ceiling can be secured. The tiles / panels are inserted and secured immediately. The last tile / panel cannot be locked, same as crossing boxes and strips. On request, the crossing boxes and strips can also be designed with an embossing for security clips.

Material required per m² (no waste included)

System without additional load [pcs/m²]

Components		a2 [mm]	700	725	1000	1300	1350	1600	1900	2025
M300125	Direct hanger for DP12 A-Bar		1.90	1.84	1.33	1.28/1.54*	0.99/1.48*	1.04	1.32/1.40*	1.32
M300138	Connection pin for DP12 A-Bar		0.72	0.70	0.50	0.40/0.60*	0.38/0.57*	0.32	0.28/0.42*	0.39
M311022	DP12 A-Bar		0.72	0.79	0.50	0.38/0.57*	0.37/0.56*	0.31	0.26/0.39*	0.37

The shown quantities are theoretical and based on an ideal layout, without considering the actual room layout. The ideal layout is based on a calculation of 10 x 10 m (100 m²). This calculation does not allow any damage, spare nor wastage. The final quantities and type of suspension have to be checked before ordering. Soffit and wall fixings by others.

* values for modules with METAL R-Clip / METAL Q-Clip

Not including perimeter trims and extraction tools.

METAL R-H 200 / METAL Q-H 100 F

U-Profile primary grid + J-Bar secondary grid
Concealed grid solution for indoor applications

General information

- Concealed hook-on grid system for medium and large rooms (METAL R-H 200), small and medium rooms (METAL Q-H 100 F)
- For perpendicular installation on U-Profile primary grid
- J-Bar made of galvanised steel
- Typical ceiling weight 7.5 - 9.0 kg/m² (METAL R-H 200), 5.5 kg/m² (METAL Q-H 100 F) (indicative value for unperforated panels / tiles, without additional load)
- Panels / tiles are easily installed and fully demountable
- Security options available
- Seismic design application available, (METAL R-H 200) see separate document
- Suitable for large panel sizes and chilled ceilings (METAL R-H 200)

Isometric view

Select the suspension option E1 - E4.
Perimeter solutions on separate datasheet.

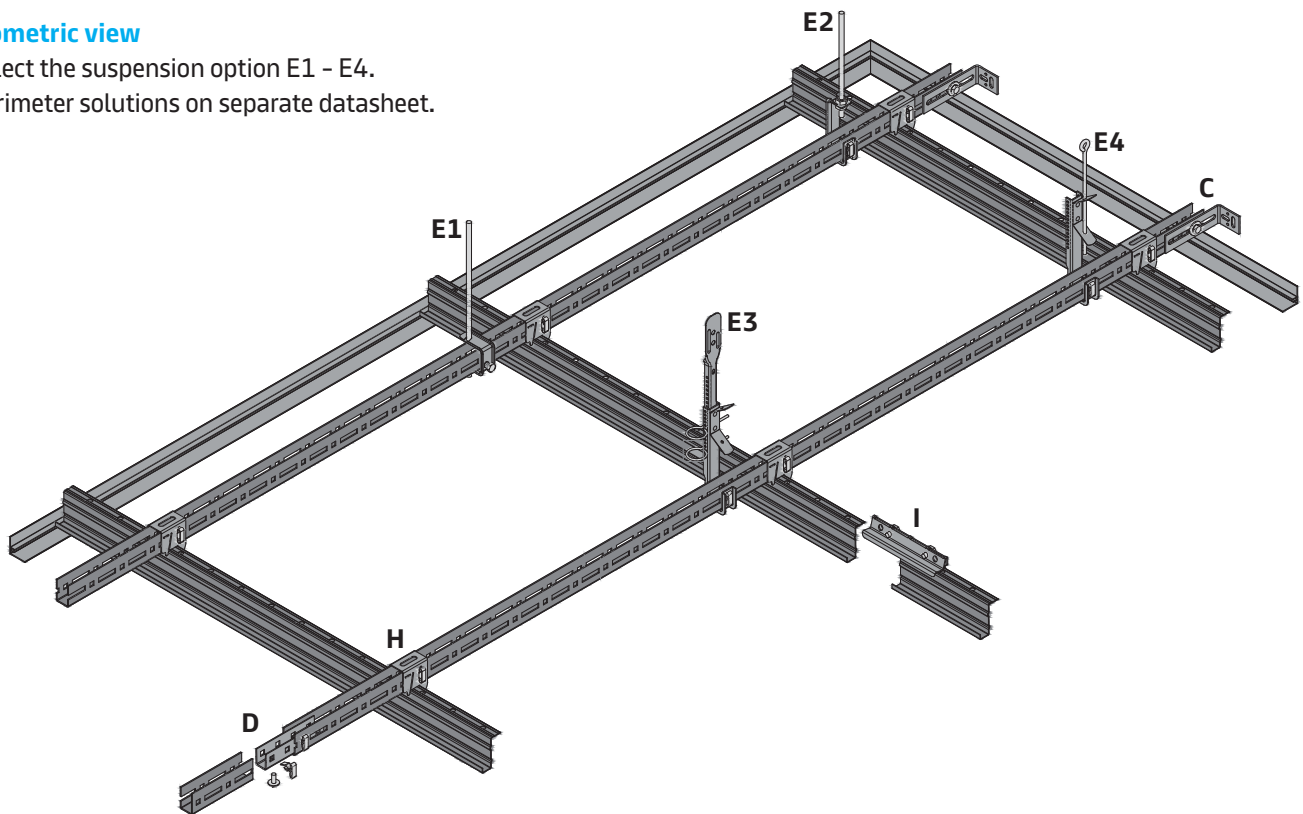

Standard, Vario Design & bespoke layout options

Standard

METAL Q-H 100 F

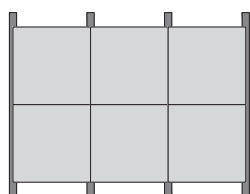

Vario Design

METAL R-H 200

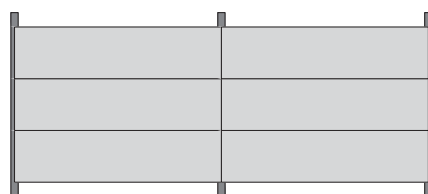

Bespoke (on request)

METAL R-H 200

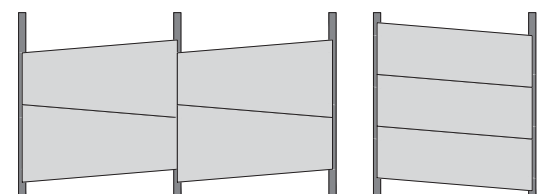

METAL R-H 200 / METAL Q-H 100 F
D02.104

Section F (METAL R-H 200)

Example with suspension option E1

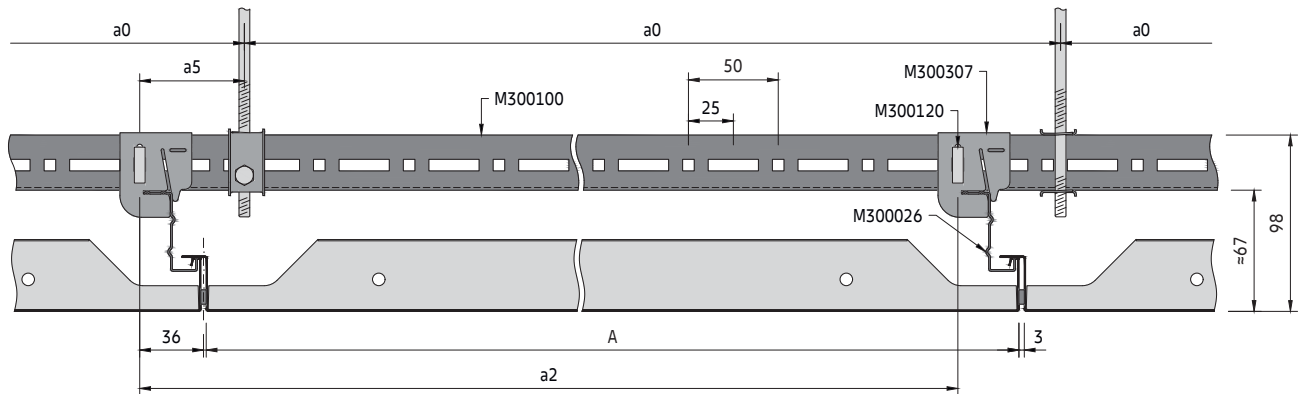

Panels supplied as standard with a 3 mm gasket on one long and one short side, to improve visual appearance. Optionally panels can be installed without a gasket.

Section F (METAL Q-H 100 F)

Example with suspension option E1

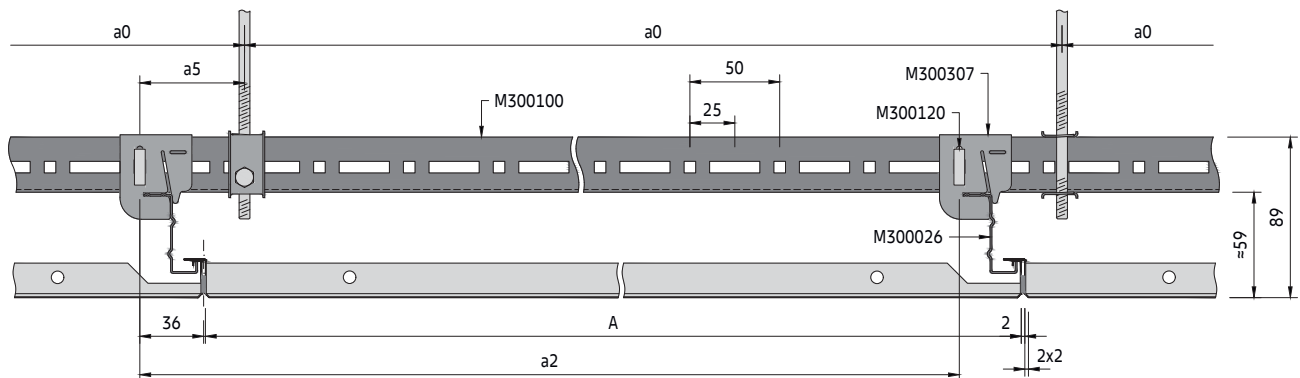

The tiles come standard with a 2 mm gasket on one long and one short side, to improve visual appearance. An option without gasket is not possible.

Secondary grid components

Standard components

- M300026 J-Bar
- M300343 Connector for J-Bar
- M300307 Hanger for J-Bar
- M300120 Plug-in clip for U-Profile

Optional components

- M300216 Security clip (METAL R-H 200)
- M311034 Extraction tool (METAL R-H 200)
- M311218 Security bracket (screwed option)
- M311191 Self-drilling screw 9.5 x 3.5mm
- M900000 Black gasket 8x3 mm (spare roll for METAL R-H 200)
- M900001 Black gasket 8x2 mm (spare roll for METAL Q-H 100 F)

See U-Profile primary grid for primary grid components

METAL R-H 200 / METAL Q-H 100 F

D02.104

J-Bar secondary grid

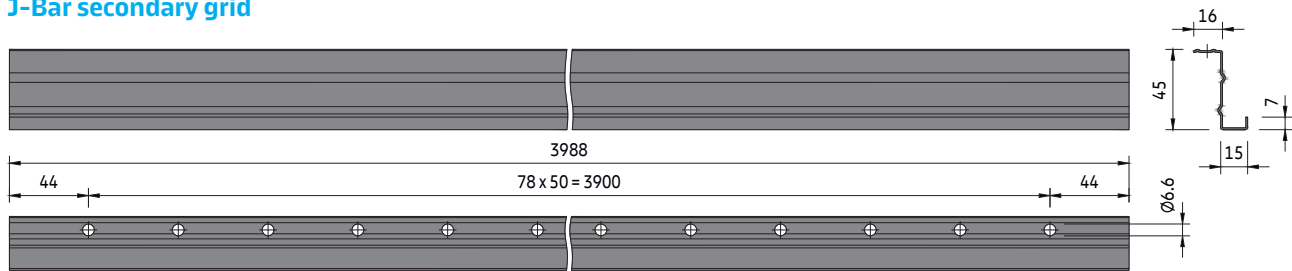

Section G (METAL R-H 200)

Example with suspension option E1

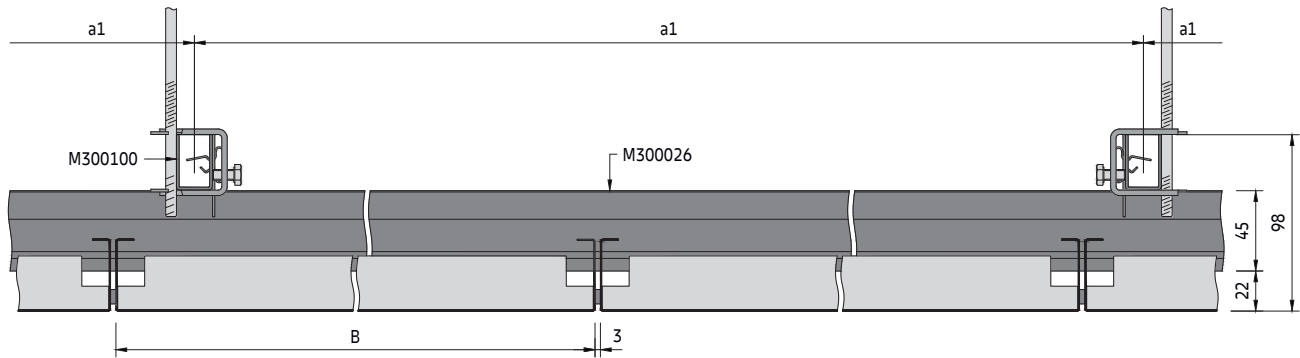

Section G (METAL Q-H 100 F)

Example with suspension option E1

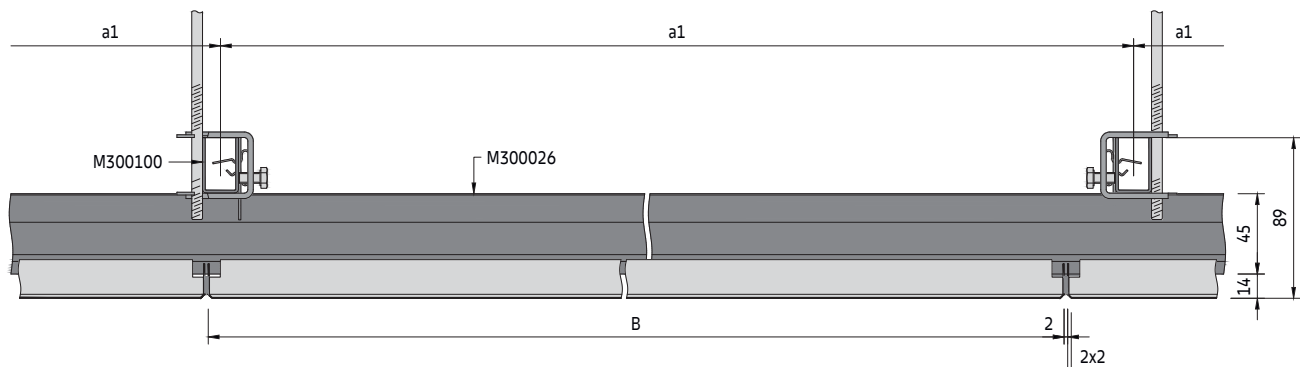

METAL R-H 200 / METAL Q-H 100 F

D02.104

Spacing

a2 [mm]	System without additional load		System with additional load +4 kg/m ²		System with additional load +6 kg/m ²	
	a0 [mm]	a1 [mm]	a0 [mm]	a1 [mm]	a0 [mm]	a1 [mm]
600	1200	1900	1200	1800	1200	1500
625	1250	1900	1250	1650	1250	1400
650	1300	1900	1300	1500	1300	1300
700	1400	1900	1400	1300	700	1800
750	1500	1750	750	1800	750	1750
800	1600	1550	800	1750	800	1700
850	1700	1300	850	1700	850	1650
900	900	1850	900	1650	900	1600
950	950	1800	950	1600	950	1550
1000	1000	1750	1000	1550	1000	1500
1050	1050	1700	1050	1550	1050	1450
1100	1100	1650	1100	1500	1100	1450
1150	1150	1650	1150	1450	1150	1400
1200	1200	1600	1200	1450	1200	1400
1250	1250	1550	1250	1400	1250	1350
1300	1300	1550	1300	1350	1300	1300
1350	1350	1500	1350	1350	1350	1200
1400	1400	1500	1400	1300	1400	1100
1450	1450	1450	1450	1200	1450	1050
1500	1500	1450	1500	1150	1500	950
1550	1550	1400	1550	1050	1550	900
1600	1600	1400	1600	1000	1600	850
1650	1650	1350	1650	850	1650	800
1700	1700	1350	1700	850	1700	750
1750	1750	1200	1750	800	1750	650
1800	1800	1150	1800	750	1800	600
1850	1850	1050	1850	650	1850	550
1900	1900	950	1900	600	1900	500
1950	975	1250	975	1100	975	1050
2000	1000	1250	1000	1100	1000	1050
2050	1025	1200	1025	1100	1025	1050
2100	1050	1200	1050	1100	1050	1050
2150	1075	1200	1075	1050	1075	1000
2200	1100	1200	1100	1050	1100	1000
2250	1125	1150	1125	1050	1125	1000
2300	1150	1150	1150	1050	1150	1000
2350	1175	1150	1175	1000	1175	1000
2400	1200	1150	1200	1000	1200	950
2450	1225	1100	1225	1000	-	-
2500	1250	1100	1250	1000	-	-
2600	1300	1100	1300	950	-	-
2700	1350	1050	1350	950	-	-
2800	1400	1050	1400	900	-	-
2900	1450	1000	1450	900	-	-
3000	1500	1000	1500	900	-	-
3100	1550	1000	1550	900	-	-
3200	1600	950	1600	850	-	-
3300	1650	950	1650	850	-	-

Typical grid layout

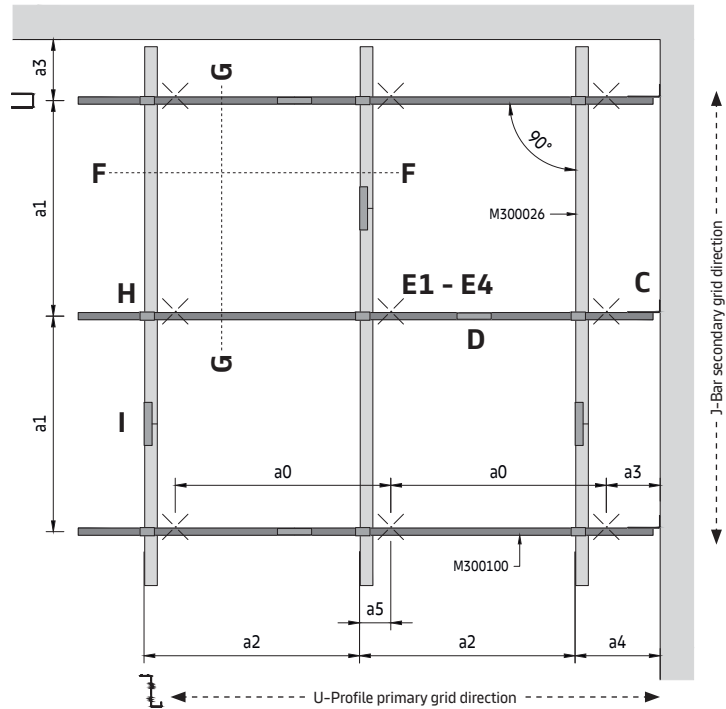

Parameters

- a0** Distance between U-Profile suspension points = max. 1900 mm
- a1** Max. distance between U-Profiles
- a2** Distance between J-Bars = panel length + gasket
- a3** Distance from wall = max. 200 mm
- a4** Distance from wall = max. panel length
- a5** Distance from U-Profile suspension point to hanger = max. 100 mm
- M** Module size = panel / tile length + gasket / panel / tile width + gasket

METAL R-H 200

- A** Panel length = min. 600 / max. 3300 mm
- B** Panel width = min. 247 / max. 1350 mm

METAL Q-H 100 F

- M** 600 x 600, 625 x 625 mm

To determine suspension layout

The module length (M) of the requested ceiling is equal to the distance between the J-Bar centres (a2). On the appropriate spacing table, read down the column headed (a2) to the required module length then read across to determine the suspension point spacing (a0) and U-Profile spacing (a1). The shown values are maximum allowed distances and can be reduced but not exceeded.

METAL R-H 200 / METAL Q-H 100 F

D02.104

Detail H

Hanger installation

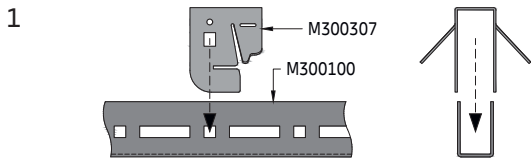

Place the hanger on the U-profile.

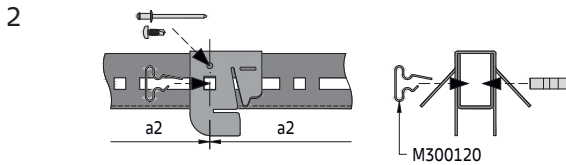

Fix hanger with plug-in clips at the specified module spacing (inserted vertically or horizontally). If the panel size does not fit with the modulation of the U-Profile (25 mm increments), the plug-in clip needs to be inserted into a long hole. The hanger position can alternatively be fixed by using a pop-rivet or self-drilling screw.

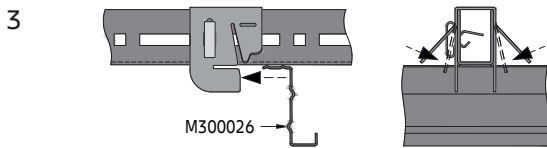

Insert the J-Bar into the hanger, press down the two hanger wings to lock the position of the J-Bar.

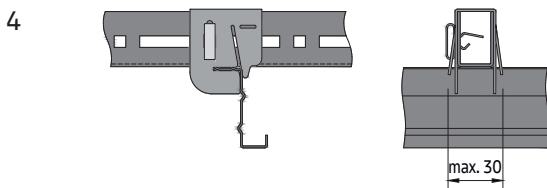

The J-Bar is now locked in position.

Detail I

Connector installation

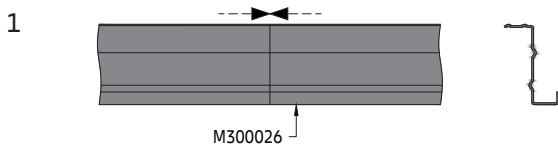

Once the J-Bars are installed under the U-Profiles, the ends should be brought together without a gap.



The connectors for the J-Bars must be inserted from above.

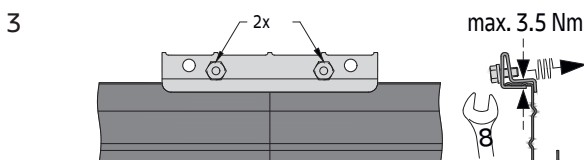

Use the bolts to secure the connector. Stagger the joints.

METAL R-H 200 / METAL Q-H 100 F

D02.104

Detail J (METAL R-H 200)

Panel insertion

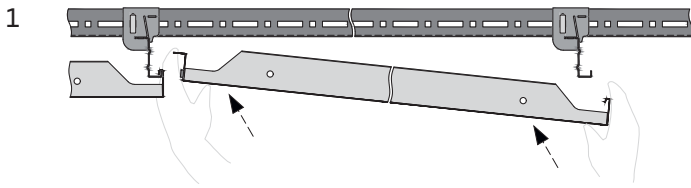

First place the panels with the outward bend short side above the neighbor panel to the left.

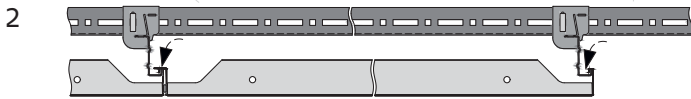

Hook-on the opposite side with the hook detail on the J-Bar to the right. The panel will rest now on the neighbor panel to the left and the J-Bar to the right.

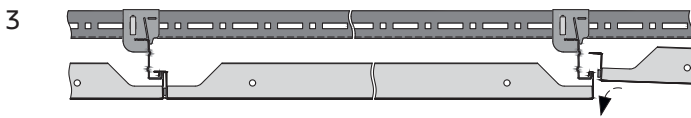

Continue with the next panel.

For METAL Q-H 100 F the sequence is the same.

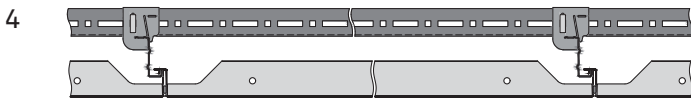

Panel extraction

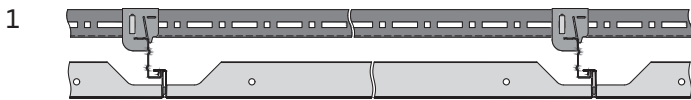

With a closed ceiling, any panel can be removed as long as there are no obstacles such as service integrations, etc.

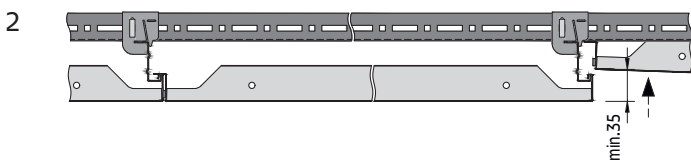

Lift the neighbor panel to the right min. 35 mm (for METAL Q-H 100 F min. 25 mm).

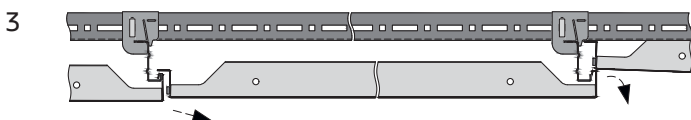

Detach the panel that is to be removed from the J-Bar.

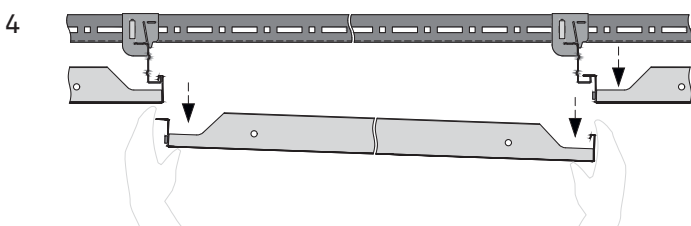

Remove it downwards and store the panel in a safe place so that it cannot be damaged. The neighbor panel will rest again on the J-Bar.

For METAL Q-H 100 F the sequence is the same.

METAL R-H 200 / METAL Q-H 100 F

D02.104

Detail K

Optional security clip (unscrewed version) for METAL R-H 200

The security clip serves to secure the panels and prevents them from being removed without the use of the appropriate extraction tool.

Panel installation / locking

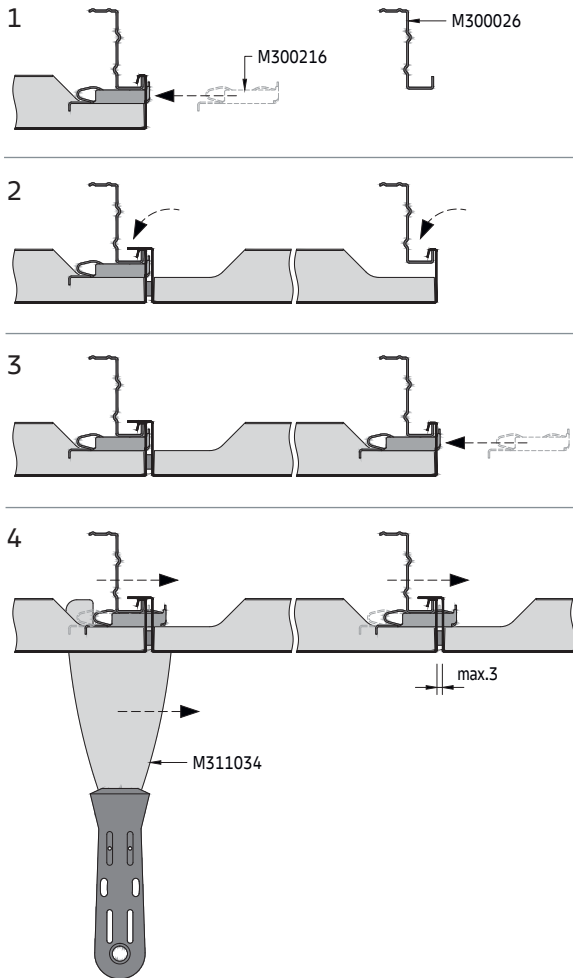

- 1 When using the optional security clip, panel by panel is installed and secured immediately. The clip is placed at the crossing point between the panels. Push the clip till it is almost flushing with the edge of the installed panel. One security clip per panel is needed and can only be used for panels with a gap of max. 3 mm.
- 2 Install the panel.
- 3 Place the next row of security clip, as described at step 1. Take the extraction tool and push the first clip row to the end position. Follow this row by row, until the ceiling is completely installed and locked.

Panel extraction / unlocking

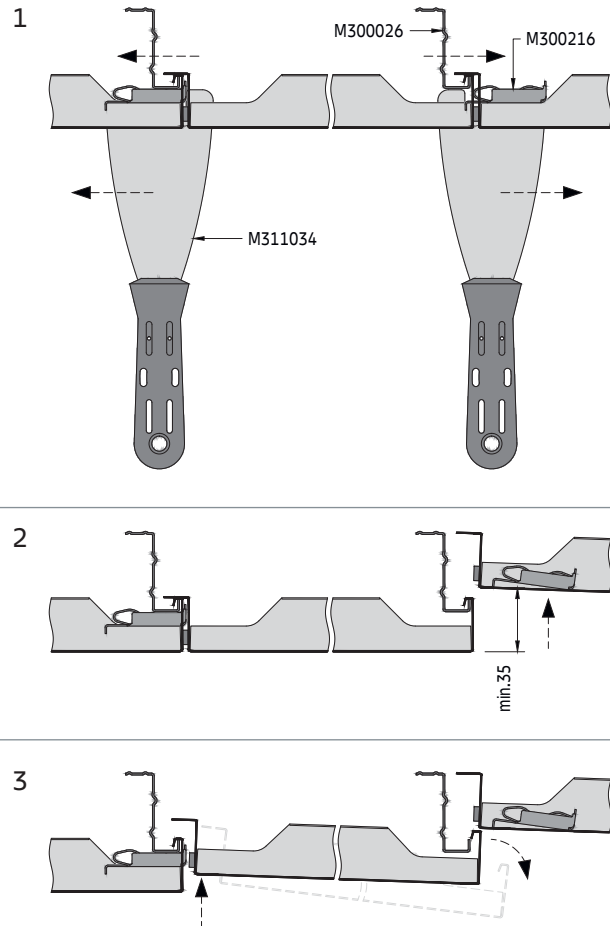

- 1 Take the extraction tool and push the four security clips away from the panel to be removed (see layout below). The security clips to the right will jump out and rest on the neighbor panel.
- 2 Lift the neighbor panel to the right min. 35 mm.
- 3 The panel can be extracted downwards, as explained in the panel extraction sequence. In order to install the panel back, the loose security clips are first collected and then installed again, as described to the left.

Locked position

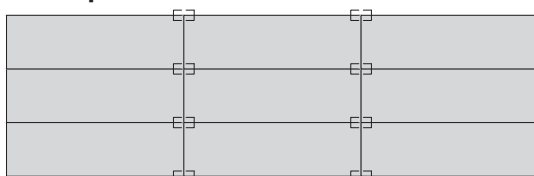

Unlocked position

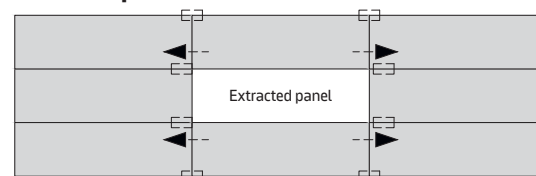

METAL R-H 200 / METAL Q-H 100 F

D02.104

Detail L

Optional security bracket (screwed version)

The security bracket serves to secure the panels and prevents them from being removed.

Panel installation / locking for METAL R-H 200

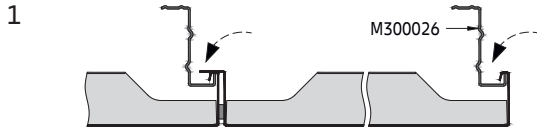

When using the screwed optional security bracket, panel by panel is installed and secured immediately.

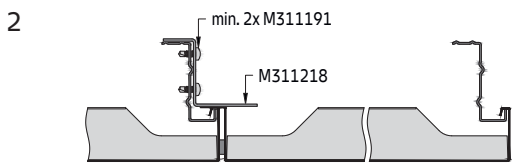

The bracket is placed at the crossing point between the panels. There are two options (A / B) of how the security bracket can be installed. Use at minimum 2 self-drilling screws to fix it. One security bracket per panel is needed.

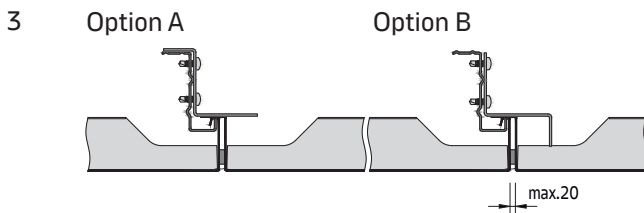

Follow this row by row, until the ceiling is completely installed and locked. The last panel remains unsecured. If panels are to be removed, the ceiling must be opened from the last panel to the desired area.

Front side view

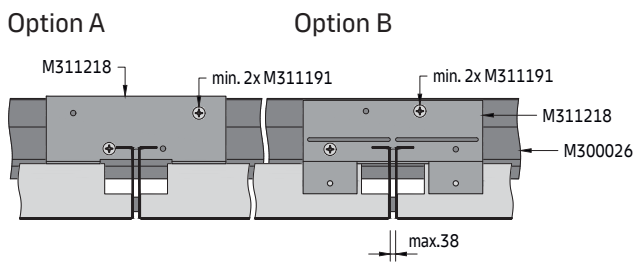

Tile locking for METAL Q-H 100 F

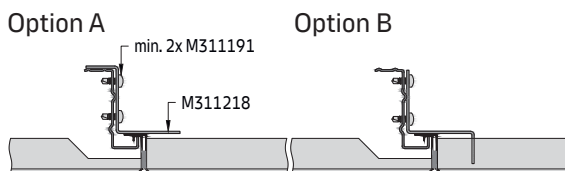

Locked position METAL R-H 200

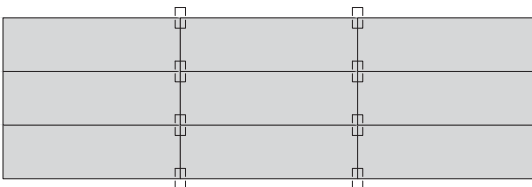

Locked position METAL Q-H 100 F

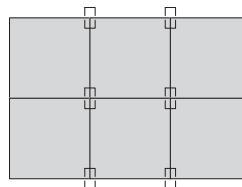

METAL R-H 200 / METAL Q-H 100 F

D02.104

Material required per m² (no waste included) METAL R-H 200 System without additional load [pcs/m²]

Components		a2 [mm]	1200	1600	1800	2000	2400	2800	3100	3300
M300026	J-Bar		0.21	0.16	0.14	0.13	0.10	0.09	0.08	0.08
M300100	U-Profile		0.17	0.19	0.23	0.21	0.23	0.26	0.27	0.28
M300119	Splice connector for U-Profile		0.17	0.20	0.24	0.22	0.24	0.26	0.27	0.29
M300120	Plug-in clip for U-Profile		0.87	0.85	0.97	0.84	0.85	0.87	0.87	0.90
M300140	Wall anchor		0.07	0.08	0.09	0.09	0.09	0.10	0.11	0.11
M300307	Hanger for J-Bar		0.53	0.45	0.49	0.40	0.37	0.35	0.33	0.32
M300343	Splice connector for J-Bar		0.21	0.16	0.14	0.13	0.11	0.09	0.09	0.08
M311103	Hexagonal nut M6		0.10	0.10	0.10	0.10	0.10	0.10	0.20	0.20
M311105	Washer		0.10	0.10	0.10	0.10	0.10	0.10	0.20	0.20
M311303	Hexagonal bolt M6 x 16 mm		0.10	0.10	0.10	0.10	0.10	0.10	0.20	0.20
Various	Suspension points (E1 - E4)		0.53	0.45	0.49	0.80	0.73	0.69	0.65	0.64

Material required per m² (no waste included) METAL Q-H 100 F System without additional load [pcs/m²]

Components		a2 [mm]	600	625
M300026	J-Bar		0.42	0.4
M300100	U-Profile		0.44	0.41
M300119	Splice connector for U-Profile		0.15	0.15
M300120	Plug-in clip for U-Profile		0.12	0.12
M300140	Wall anchor		0.06	0.06
M300307	Hanger for J-Bar		0.88	0.85
M300343	Splice connector for J-Bar		0.42	0.41
M311103	Hexagonal nut M6		0.10	0.10
M311105	Washer		0.10	0.10
M311303	Hexagonal bolt M6 x 16 mm		0.10	0.10
Various	Suspension points (E1 - E4)		0.44	0.43

The shown quantities are theoretical and based on an ideal layout, without considering the actual room layout. The ideal layout is based on a calculation of 10 x 10 m (100 m²). This calculation does not allow any damage, spare nor wastage. The final quantities and type of suspension have to be checked before ordering. Soffit and wall fixings by others.

Not including perimeter trims, optional security brackets and extraction tools.



METAL R-H 200 / METAL Q-H 100 F

Primary angle primary grid + J-Bar secondary grid
Concealed grid solution for indoor applications

General information

- Concealed hook-on grid system for medium and large rooms (METAL R-H 200), small and medium rooms (METAL Q-H 100 F)
- For perpendicular or radial installation on primary angle primary grid (27 x 22 / 50 x 22 mm option)
- J-Bar made of galvanised steel
- Typical ceiling weight 7.5 - 9.0 kg/m² (METAL R-H 200), 5.5 kg/m² (METAL Q-H 100 F) (indicative value for unperforated panels / tiles, without additional load)
- Panels / tiles are easily installed and fully demountable
- Security options available
- Suitable for large panel sizes and chilled ceilings (METAL R-H 200)

Isometric view

Select the suspension option E1 - E4.
Perimeter solutions on separate datasheet.

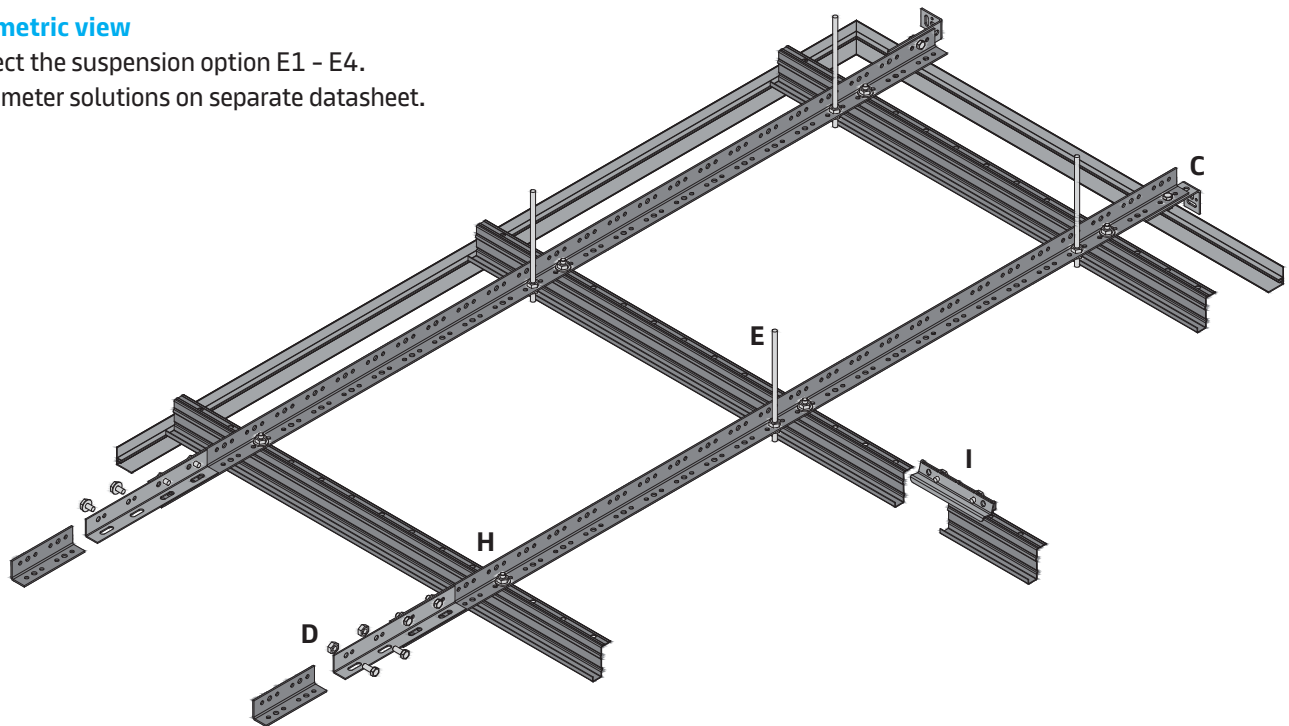

Standard, Vario Design & bespoke layout options

Standard

METAL Q-H 100 F

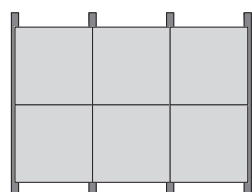

Vario Design

METAL R-H 200

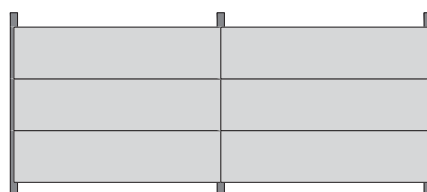

Bespoke (on request)

METAL R-H 200

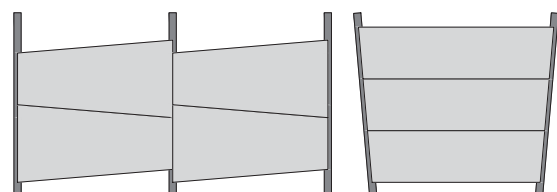

METAL R-H 200 / METAL Q-H 100 F
D02.104.1

Section F (METAL R-H 200)

Example with primary angle 27 x 22 mm

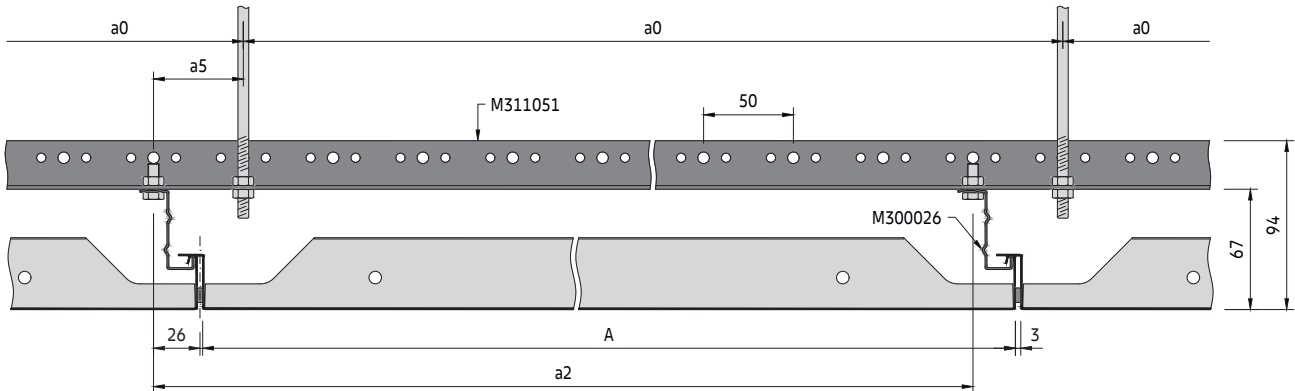

Panels supplied as standard with a 3 mm gasket on one long and one short side, to improve visual appearance. Optionally panels can be installed without a gasket.

Section F (METAL Q-H 100 F)

Example with primary angle 27 x 22 mm

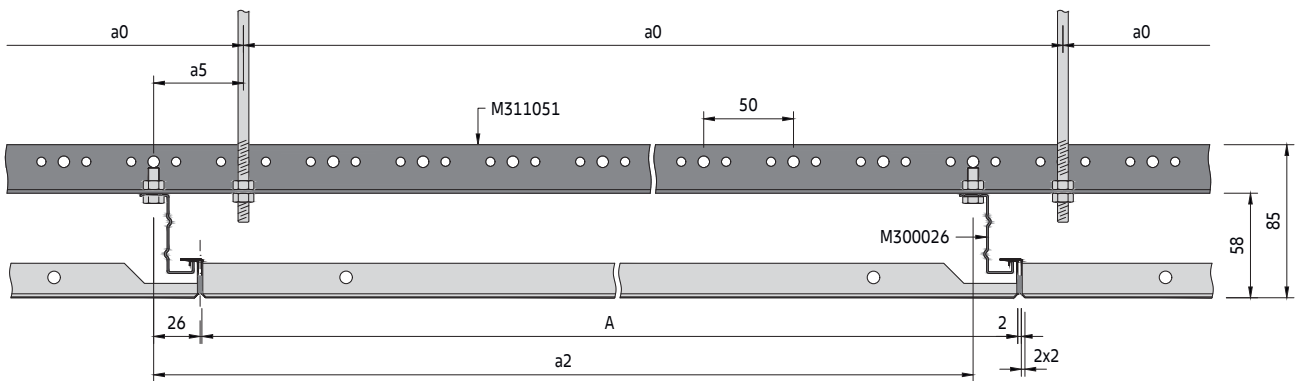

The tiles come standard with a 2 mm gasket on one long and one short side, to improve visual appearance. An option without gasket is not possible.

Secondary grid components

Standard components

- M300026 J-Bar
- M300343 Splice connector for J-Bar

Optional components

- M300216 Security clip (METAL R-H 200)
- M311034 Extraction tool (METAL R-H 200)
- M311218 Security bracket (screwed option)
- M311191 Self-drilling screw 3.5 x 9.5 mm
- M900000 Black gasket 8x3 mm (spare roll for METAL R-H 200)
- M900001 Black gasket 8x2 mm (spare roll for METAL Q-H 100 F)

See primary angle primary grid for primary grid components

J-Bar secondary grid

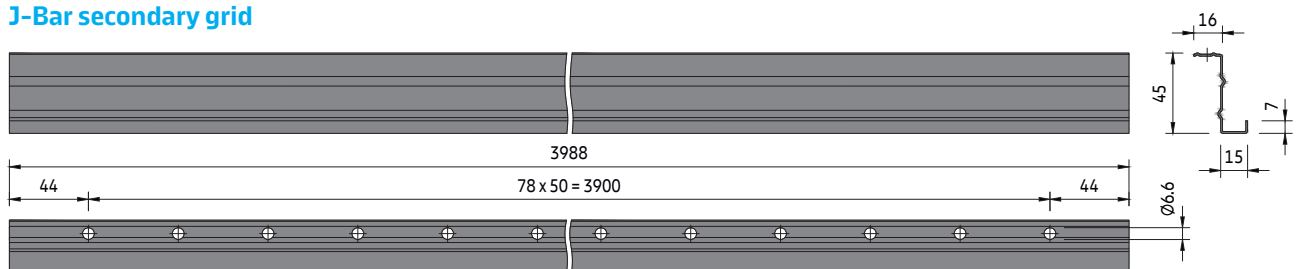

METAL R-H 200 / METAL Q-H 100 F

D02.104.1

Section G (METAL R-H 200)

Example with primary angle 27 x 22 and 50 x 22 mm

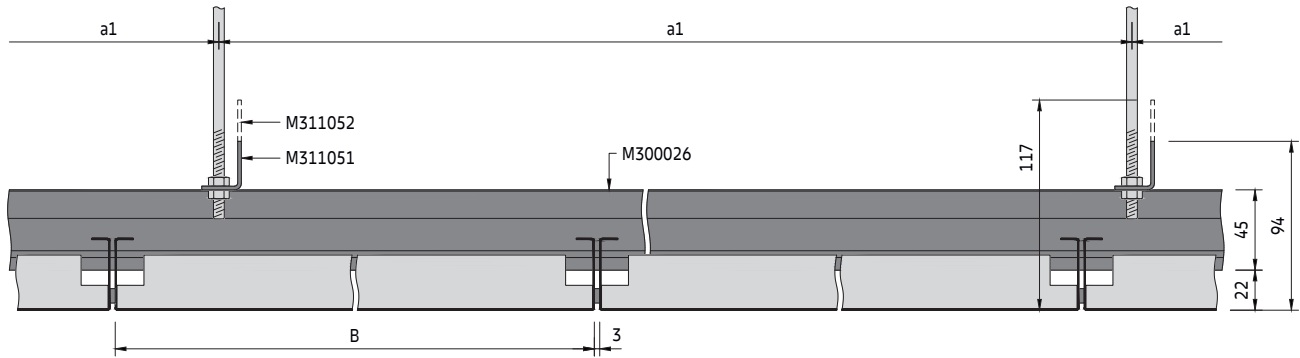

Section G (METAL Q-H 100 F)

Example with primary angle 27 x 22 and 50 x 22 mm

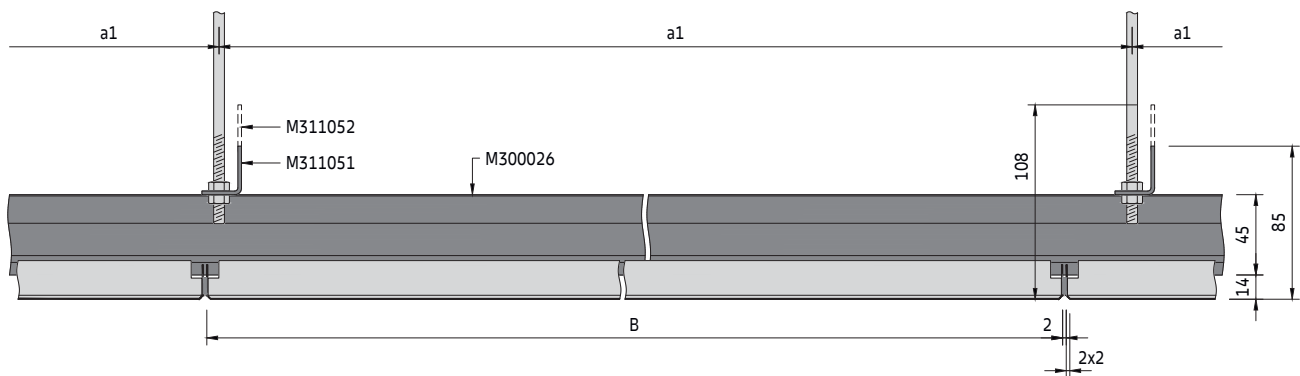

Detail H

J-Bar fixing

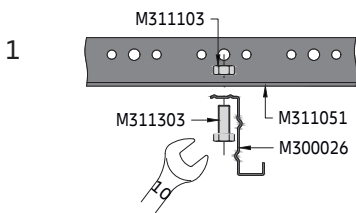

Use an M6 bolt and nut to screw the J-Bar below the primary angle.

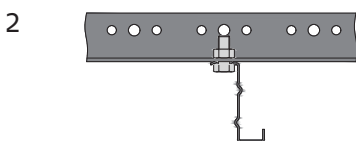

The J-Bar is now fixed.

Detail I

Splice connection

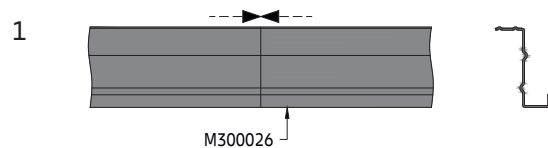

Once the J-Bars are installed under the U-Profiles, the ends should be brought together without a gap.



The connectors for the J-Bars must be inserted from above.

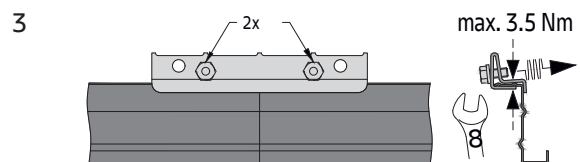

Use the bolts to secure the connector. Stagger the joints.

METAL R-H 200 / METAL Q-H 100 F

D02.104.1

Detail J (METAL R-H 200)

Panel insertion

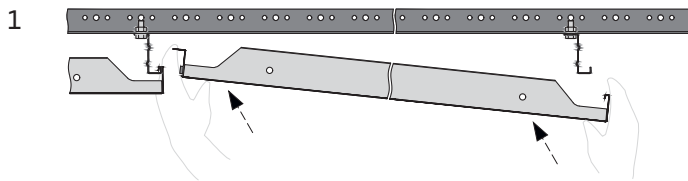

First place the panels with the outward bend short side above the neighbor panel to the left.

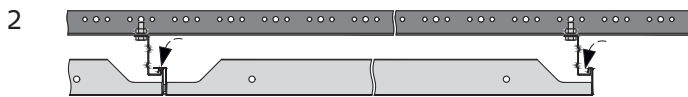

Hook-on the opposite side with the hook detail on the J-Bar to the right. The panel will rest now on the neighbor panel to the left and the J-Bar to the right.

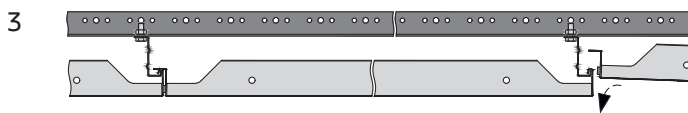

Continue with the next panel.

For METAL Q-H 100 F the sequence is the same.

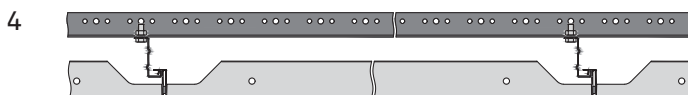

Panel extraction

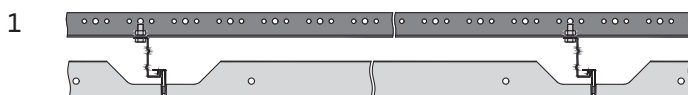

With a closed ceiling, any panel can be removed as long as there are no obstacles such as service integrations, etc.

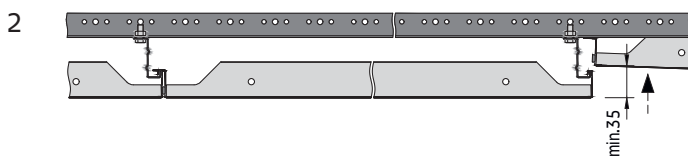

Lift the neighbor panel to the right min. 35 mm (for METAL Q-H 100 F min. 25 mm).

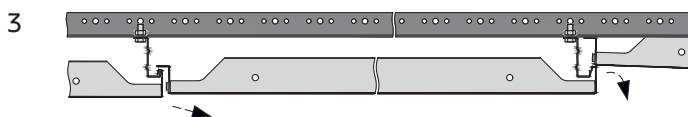

Detach the panel that is to be removed from the J-Bar.

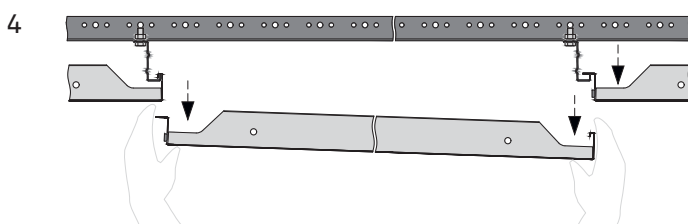

Remove it downwards and store the panel in a safe place so that it cannot be damaged. The neighbor panel will rest again on the J-Bar.

For METAL Q-H 100 F the sequence is the same.

METAL R-H 200 / METAL Q-H 100 F

D02.104.1

Spacing for primary angle 27 x 22 mm

a2 [mm]	System without additional load		System with additional load +4 kg/m ²		System with additional load +6 kg/m ²	
	a0 [mm]	a1 [mm]	a0 [mm]	a1 [mm]	a0 [mm]	a1 [mm]
600	1200	1500	1200	1500	1200	1200
625	1250	1500	1250	1200	1250	1200
650	1300	1500	1300	1200	1300	1000
700	1400	1500	1400	1500	1400	1200
750	1500	1500	750	1500	750	1200
800	1600	1500	800	1500	800	1200
850	1700	1200	850	1500	850	1200
900	900	1500	900	1500	900	1200
950	950	1500	950	1200	950	1000
1000	1000	1500	1000	1200	1000	1000
1050	1050	1500	1050	1200	1050	1000
1100	1100	1500	1100	1200	1100	1000
1150	1150	1500	1150	1200	1150	1000
1200	1200	1500	1200	1200	1200	1000
1250	1250	1500	1250	1200	1250	1000
1300	1300	1500	1300	1200	1300	1000
1350	1350	1200	1350	1200	1350	1000
1400	1400	1200	1400	1200	1400	1000
1450	1450	1200	1450	1000	1450	750
1500	1500	1200	1500	1000	1500	750
1550	1550	1200	1550	1000	1550	750
1600	1600	1200	1600	750	1600	600
1650	1650	1200	1650	750	1650	600
1700	1700	1200	1700	750	1700	600
1750	1750	1000	1750	750	1750	600
1800	1800	1000	1800	600	1800	500
1850	1850	750	1850	600	1850	500
1900	1900	750	1900	500	950	1000
1950	975	1000	975	1000	975	750
2000	1000	1000	1000	1000	1000	750
2050	1025	1000	1025	1000	1025	750
2100	1050	1000	1050	1000	1050	750
2150	1075	1000	1075	750	1075	600
2200	1100	1000	1100	750	1100	600
2250	1125	1000	1125	750	1125	600
2300	1150	1000	1150	750	1150	600
2350	1175	1000	1175	750	1175	600
2400	1200	1000	1200	750	1200	600
2450	1225	1000	1225	750	-	-
2500	1250	1000	1250	750	-	-
2600	1300	1000	1300	750	-	-
2700	1350	750	1350	750	-	-
2800	1400	750	1400	750	-	-
2900	1450	750	1450	750	-	-
3000	1500	750	1500	750	-	-
3100	1550	750	1550	750	-	-
3200	1600	750	1600	600	-	-
3300	1650	750	1650	600	-	-

Spacing for primary angle 50 x 22 mm

a2 [mm]	System without additional load		System with additional load +4 kg/m ²		System with additional load +6 kg/m ²	
	a0 [mm]	a1 [mm]	a0 [mm]	a1 [mm]	a0 [mm]	a1 [mm]
600	1200	1900	1200	1900	1200	1900
625	1250	1900	1250	1900	1250	1900
650	1300	1900	1300	1900	1300	1900
700	1400	1900	1400	1900	1400	1850
750	1500	1900	750	1900	750	1800
800	1600	1900	800	1900	800	1800
850	1700	1900	850	1900	850	1750
900	900	1900	900	1650	900	1700
950	950	1900	950	1400	950	1700
1000	1000	1900	1000	1900	1000	1650
1050	1050	1900	1050	1850	1050	1650
1100	1100	1900	1100	1850	1100	1600
1150	1150	1900	1150	1800	1150	1600
1200	1200	1900	1200	1800	1200	1550
1250	1250	1900	1250	1750	1250	1550
1300	1300	1900	1300	1750	1300	1500
1350	1350	1900	1350	1700	1350	1500
1400	1400	1900	1400	1700	1400	1500
1450	1450	1900	1450	1650	1450	1450
1500	1500	1900	1500	1650	1500	1450
1550	1550	1900	1550	1650	1550	1450
1600	1600	1900	1600	1600	1600	1400
1650	1650	1900	1650	1600	1650	1400
1700	1700	1850	1700	1600	1700	1350
1750	1750	1850	1750	1550	1750	1250
1800	1800	1850	1800	1550	1800	1150
1850	1850	1800	1850	1550	1850	1050
1900	1900	1800	1900	1450	1900	950
1950	975	1800	975	1500	975	1350
2000	1000	1800	1000	1500	1000	1300
2050	1025	1750	1025	1500	1025	1300
2100	1050	1750	1050	1450	1050	1300
2150	1075	1750	1075	1450	1075	1300
2200	1100	1700	1100	1450	1100	1300
2250	1125	1700	1125	1450	1125	1250
2300	1150	1700	1150	1450	1150	1250
2350	1175	1700	1175	1450	1175	1250
2400	1200	1700	1200	1400	1200	1250
2450	1225	1650	1225	1400	-	-
2500	1250	1650	1250	1400	-	-
2600	1300	1650	1300	1400	-	-
2700	1350	1650	1350	1350	-	-
2800	1400	1600	1400	1350	-	-
2900	1450	1600	1450	1350	-	-
3000	1500	1550	1500	1300	-	-
3100	1550	1550	1550	1300	-	-
3200	1600	1550	1600	1300	-	-
3300	1650	1500	1650	1300	-	-

METAL R-H 200 / METAL Q-H 100 F

D02.104.1

Parameters

- a0 Distance between primary angle suspension points = max. 1900 mm
- a1 Max. distance between primary angles
- a2 Distance between J-Bars = panel length + gasket
- a3 Distance from wall = max. 200 mm
- a4 Distance from wall = max. panel length
- a5 Distance from primary angle suspension point to hanger = max. 100 mm
- M Module size = panel / tile length + gasket / panel / tile width + gasket

METAL R-H 200

- A Panel length = min. 600 / max. 3300 mm
- B Panel width = min. 247 / max. 1350 mm

METAL Q-H 100 F

- M 600 x 600, 625 x 625 mm

Typical grid layout

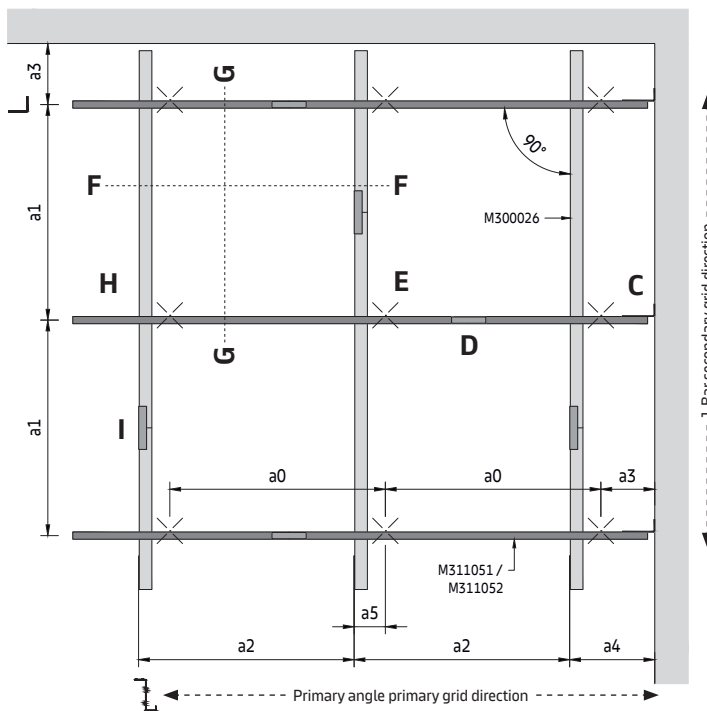

To determine suspension layout

The module length (M) of the requested ceiling is equal to the distance between the DP12 A-Bar centres (a2).
 On the appropriate spacing table, read down the column headed (a2) to the required module length then read across to determine the suspension point spacing (a0) and direct hanger spacing (a1).
 The shown values are maximum allowed distances and can be reduced but not exceeded.

METAL R-H 200 / METAL Q-H 100 F
D02.104.1

Detail K

Optional security clip (unscrewed version) for METAL R-H 200

The security clip serves to secure the panels and prevents them from being removed without the use of the appropriate extraction tool.

Panel installation / locking

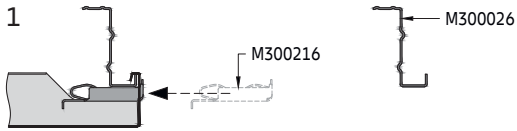

When using the optional security clip, panel by panel is installed and secured immediately. The clip is placed at the crossing point between the panels. Push the clip till it is almost flushing with the edge of the installed panel. One security clip per panel is needed and can only be used for panels with a gap of max. 3 mm.

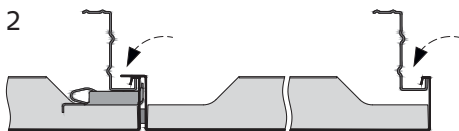

Install the panel.

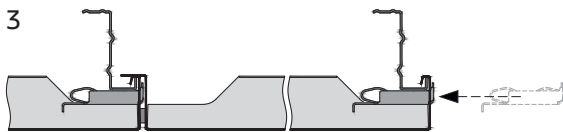

Place the next row of security clips, as described at step 1. Take the extraction tool and push the first clip row to the end position. Insert the extraction tool carefully to avoid damaging the gasket. Follow this row by row, until the ceiling is completely installed and locked.

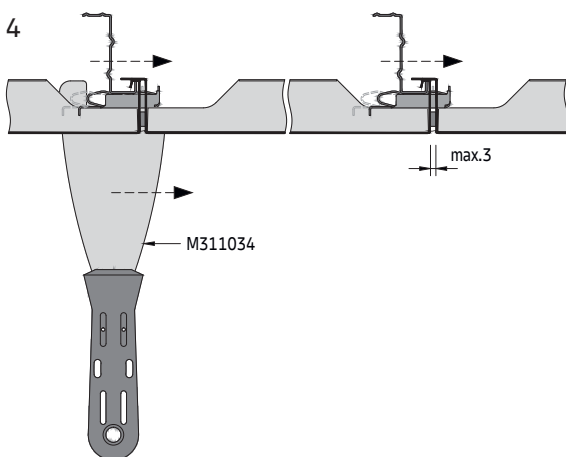

Locked position

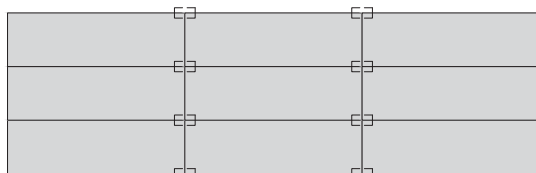

Panel extraction / unlocking

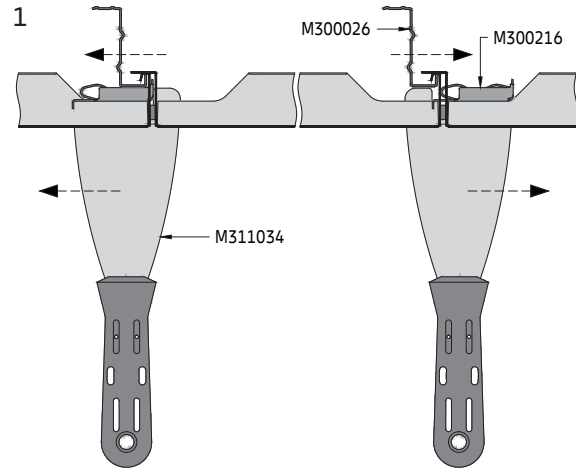

Take the extraction tool and push the four security clips away from the panel to be removed (see layout below). Insert the extraction tool carefully to avoid damaging the gasket. The security clips to the right will jump out and rest on the neighbor panel.

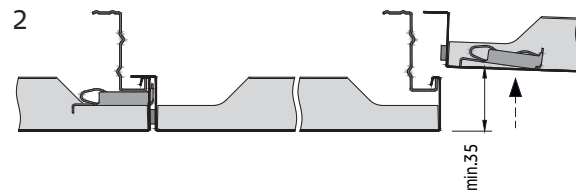

Lift the neighbor panel to the right min. 35 mm.

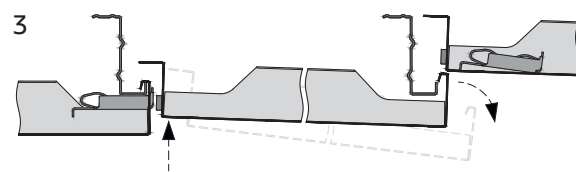

The panel can be extracted downwards, as explained in the panel extraction sequence. In order to install the panel back, the loose security clips are first collected and then installed again, as described to the left.

Unlocked position

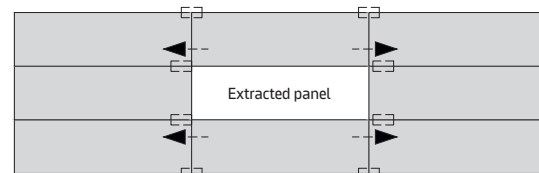

METAL R-H 200 / METAL Q-H 100 F

D02.104.1

Detail L

Optional security bracket (screwed version)

The security bracket serves to secure the panels and prevents them from being removed.

Panel installation / locking for METAL R-H 200

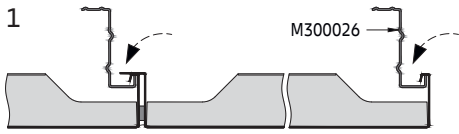

When using the screwed optional security bracket, panel by panel is installed and secured immediately.

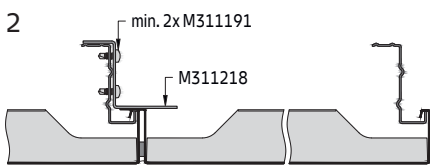

The bracket is placed at the crossing point between the panels. There are two options (A / B) of how the security bracket can be installed. Use at minimum 2 self-drilling screws to fix it. One security bracket per panel is needed.

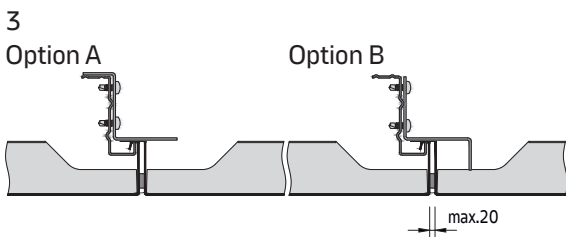

Follow this row by row, until the ceiling is completely installed and locked. The last panel remains unsecured. If panels are to be removed, the ceiling must be opened from the last panel to the desired area.

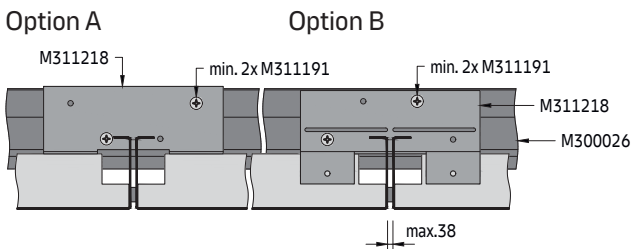

Tile locking for METAL Q-H 100 F

Option A Option B

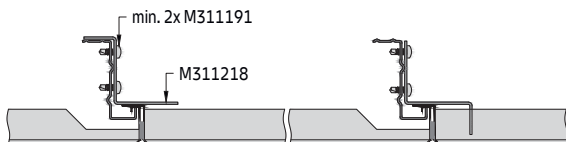

Locked position METAL R-H 200

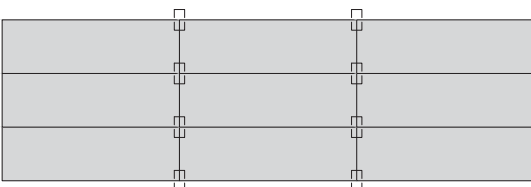

Locked position METAL Q-H 100 F

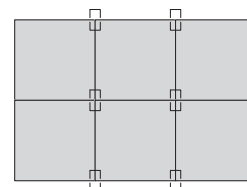

METAL R-H 200 / METAL Q-H 100 F

D02.104.1

Material required per m² (no waste included) METAL R-H 200 System without additional load [pcs/m²]

Components		a2 [mm]	1200	1600	1800	2000	2400	2800	3100	3300
M300026	J-Bar		0.21	0.16	0.14	0.13	0.10	0.09	0.08	0.08
M311051	Primary angle 27 x 22 mm		0.23	0.28	0.33	0.33	0.33	0.44	0.44	0.44
M311053	Splice connector for primary angle *		0.23	0.28	0.34	0.34	0.34	0.45	0.45	0.45
M300140	Wall anchor		0.07	0.08	0.09	0.09	0.09	0.10	0.11	0.11
M300343	Splice connector for J-Bar		0.21	0.16	0.14	0.13	0.11	0.09	0.09	0.08
M311099	Threaded rod M6 x 1000 mm		0.56	0.53	0.56	1.00	0.84	0.96	0.87	0.81
M311103	Hexagonal nut M6		0.16	0.17	0.2	0.25	0.23	0.29	0.28	0.28
M311105	Washer		0.10	0.10	0.10	0.10	0.10	0.10	0.20	0.20
M311303	Hexagonal bolt M6 x 16 mm		0.16	0.17	0.2	0.25	0.23	0.29	0.28	0.28

*Option with M6 bolt and nut

Material required per m² (no waste included) METAL Q-H 100 F System without additional load [pcs/m²]

Components		a2 [mm]	600	625
M300026	J-Bar		0,42	0,4
M311051	Primary angle 27 x 22 mm		0,22	0,22
M311053	Splice connector for primary angle *		0,23	0,23
M300140	Wall anchor		0,06	0,06
M300343	Splice connector for J-Bar		0,42	0,41
M311099	Threaded rod M6 x 1000 mm		0,56	0,54
M311103	Hexagonal nut M6		0,16	0,16
M311105	Washer		0,1	0,1
M311303	Hexagonal bolt M6 x 16 mm		0,16	0,16

*Option with M6 bolt and nut

The shown quantities are theoretical and based on an ideal layout, without considering the actual room layout. The ideal layout is based on a calculation of 10 x 10 m (100 m²). This calculation does not allow any damage, spare nor wastage. The final quantities and type of suspension have to be checked before ordering. Soffit and wall fixings by others.

Not including perimeter trims, optional security brackets and extraction tools.



METAL R-H 200
Varso Tower, Warsaw, Poland
© Szymon Polański

METAL R-H 200 / METAL Q-H 100 F

Direct suspended J-Bar
Concealed grid solution for indoor applications

General information

- Concealed hook-on grid system for small rooms with low cavity
- For perpendicular or radial installation
- J-Bar made of galvanised steel
- Typical ceiling weight 7.0 - 8.5 kg/m² (METAL R-H 200), 5.0 kg/m² (METAL Q-H 100 F) (indicative value for unperforated panels / tiles, without additional load)
- Panels / tiles are easily installed and fully demountable
- Security options available

Isometric view

Perimeter solutions on separate datasheet.

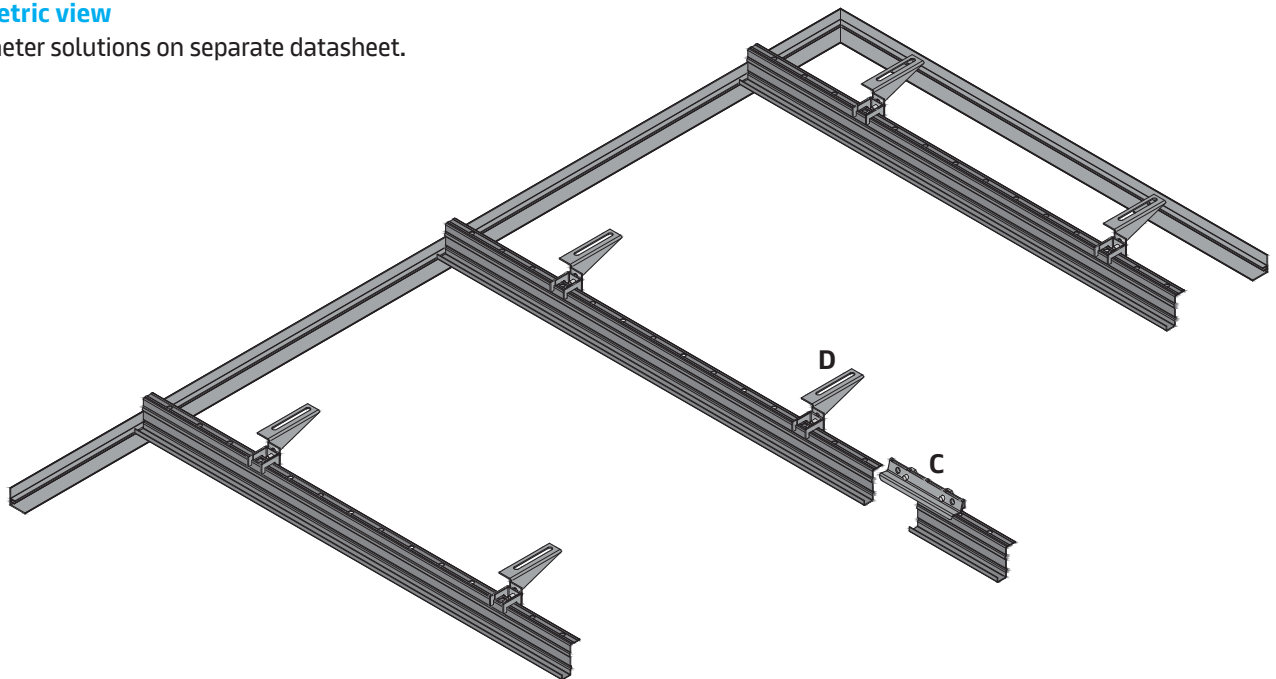

The use of a primary grid system is recommended, as this simplifies levelling and the alignment of the ceiling.

Standard, Vario Design & bespoke layout options

Standard

METAL Q-H 100 F

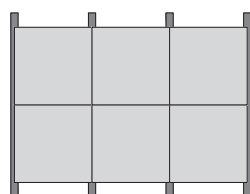

Vario Design

METAL R-H 200

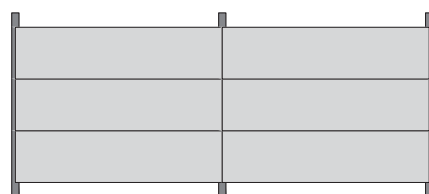

Bespoke (on request)

METAL R-H 200

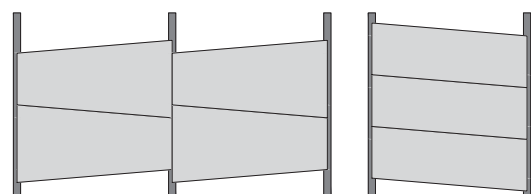

METAL R-H 200 / METAL Q-H 100 F

D02.104.2

Section A (METAL R-H 200)

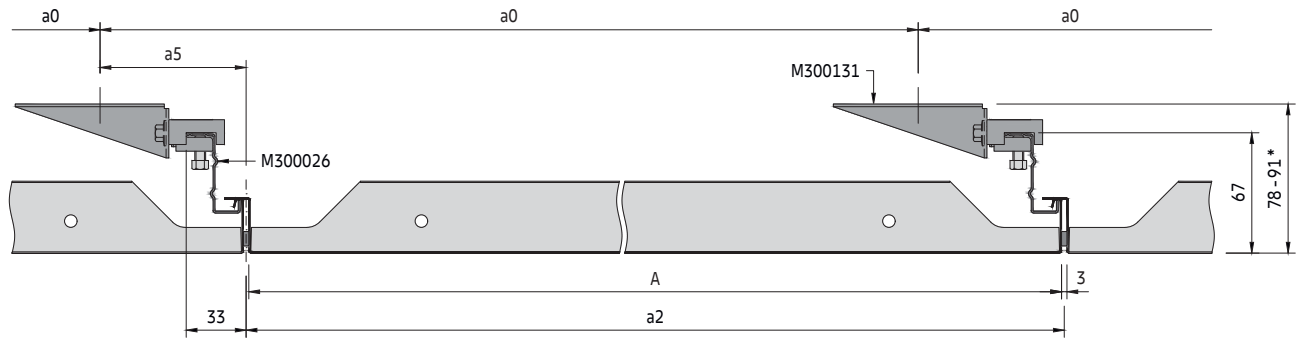

Panels supplied as standard with a 3 mm gasket on one long and one short side, to improve visual appearance. Optionally panels can be installed without a gasket.

* Large panels with a long edge height of 55 mm require a minimum installation height of 83 mm.

Section A (METAL Q-H 100 F)

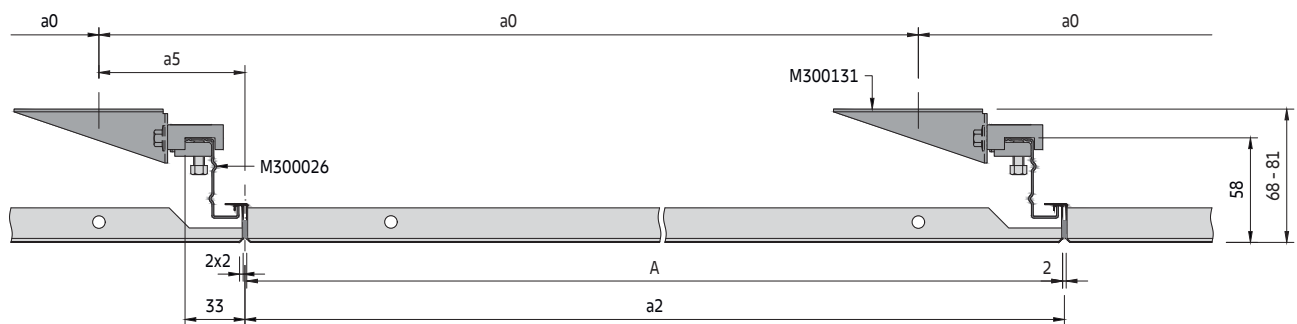

The tiles come standard with a 2 mm gasket on one long and one short side, to improve visual appearance. An option without gasket is not possible.

Secondary grid components

Standard components

- M300026 J-Bar
- M300343 Splice connector for J-Bar
- M300131 Direct hanger for J-Bar

Optional components

- M300216 Security clip (METAL R-H 200)
- M311034 Extraction tool (METAL R-H 200)
- M311218 Security bracket (screwed option)
- M311191 Self-drilling screw 3.5 x 9.5 mm
- M900000 Black gasket 8 x 3 mm (spare roll for METAL R-H 200)
- M900001 Black gasket 8 x 2 mm (spare roll for METAL Q-H 100 F)

See primary angle primary grid for primary grid components

J-Bar

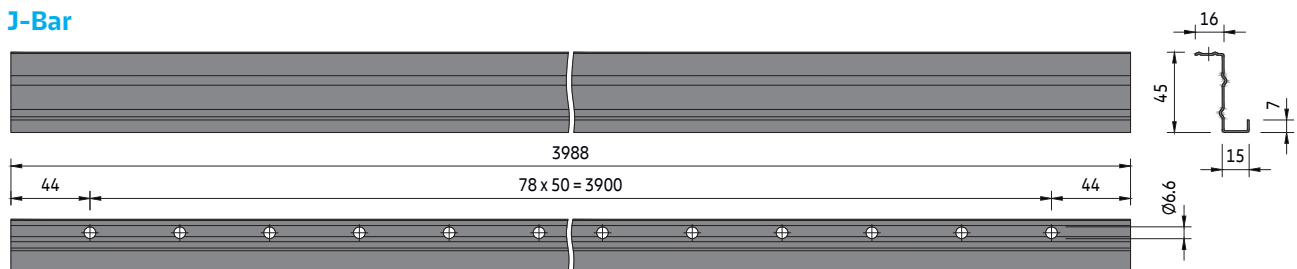

METAL R-H 200 / METAL Q-H 100 F

D02.104.2

Section B (METAL R-H 200)

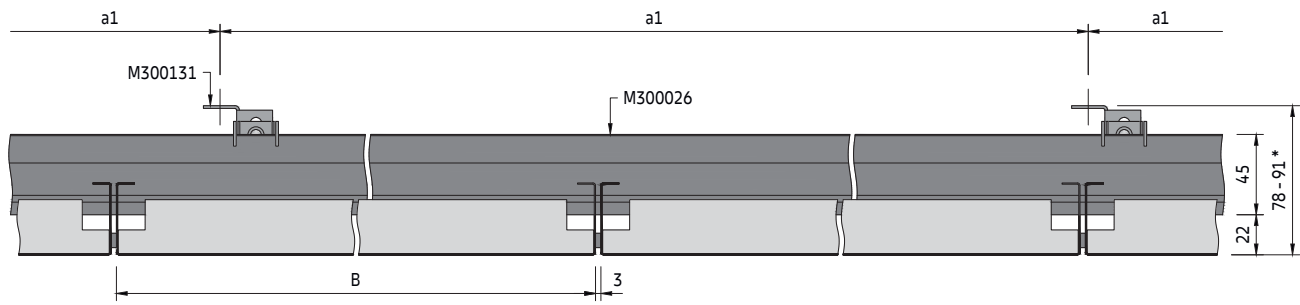

* Large panels with a long edge height of 55 mm require a minimum installation height of 83 mm.

Section B (METAL Q-H 100 F)

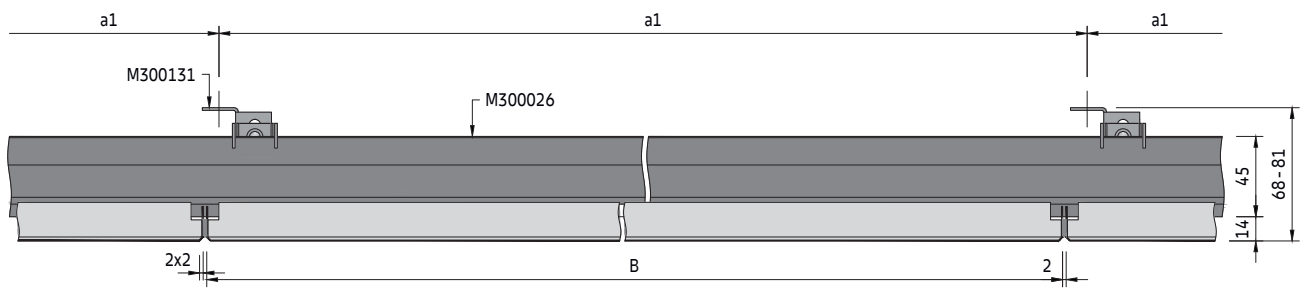

METAL R-H 200 / METAL Q-H 100 F

D02.104.2

Spacing

a2 [mm]	System without additional load		System with additional load +4 kg/m ²		System with additional load +6 kg/m ²	
	a0 [mm]	a1 [mm]	a0 [mm]	a1 [mm]	a0 [mm]	a1 [mm]
600	600	1500	600	1500	600	1500
625	625	1500	625	1500	625	1500
650	650	1500	650	1500	650	1500
700	700	1500	700	1500	700	1500
750	750	1500	750	1500	750	1500
800	800	1500	800	1500	800	1500
850	850	1500	850	1500	850	1500
900	900	1500	900	1500	900	1500
950	950	1500	950	1500	950	1500
1000	1000	1500	1000	1500	1000	1200
1050	1050	1500	1050	1500	1050	1200
1100	1100	1500	1100	1500	1100	1200
1150	1150	1500	1150	1200	1150	1200
1200	1200	1500	1200	1200	1200	1200
1250	1250	1500	1250	1200	1250	1200
1300	1300	1500	1300	1200	1300	1000
1350	1350	1500	1350	1200	1350	1000
1400	1400	1500	1400	1200	1400	1000
1450	1450	1200	1450	1200	1450	1000
1500	1500	1200	1500	1000	1500	1000
1550	1550	1200	1550	1000	1550	800
1600	1600	1200	1600	1000	1600	800
1650	1650	1200	1650	800	1650	800
1700	1700	1200	1700	800	1700	600
1750	1750	1200	1750	800	1750	600
1800	1800	1000	1800	600	1800	600
1850	1850	1000	1850	600	1850	400
1900	1900	800	1900	600	1900	400
1950	1950	800	1950	600	1950	400
2000	2000	800	2000	600	2000	400
2050	2050	800	2050	600	2050	400
2100	2100	800	2100	600	2100	400
2150	2150	800	2150	600	2150	400
2200	2200	800	2200	600	2200	400
2250	2250	800	2250	400	2250	400
2300	2300	800	2300	400	2300	400
2350	2350	600	2350	400	2350	400
2400	2400	600	2400	400	2400	400
2450	2450	600	2450	400	-	-
2500	2500	600	2500	400	-	-
2600	2600	600	2600	400	-	-
2700	2700	600	2700	400	-	-
2800	2800	600	2800	400	-	-
2900	2900	600	2900	400	-	-
3000	3000	600	3000	400	-	-
3100	3100	600	3100	400	-	-
3200	3200	600	3200	400	-	-
3300	3300	600	3300	400	-	-

Parameters

- a0 Distance between J-Bar suspension points = max. 1900 mm
- a1 Max. distance between direct hangers
- a2 Distance between J-Bars = panel length + gasket
- a3 Distance from wall = max. 200 mm
- a4 Distance from wall = max. panel length
- a5 Distance between tile / panel joint and top fixing = max. 80 mm
- M Module size = panel / tile length + gasket / panel / tile width + gasket

METAL R-H 200

- A Panel length = min. 600 / max. 3300 mm
- B Panel width = min. 247 / max. 1350 mm

METAL Q-H 100 F

- M 600 x 600, 625 x 625 mm

Typical grid layout

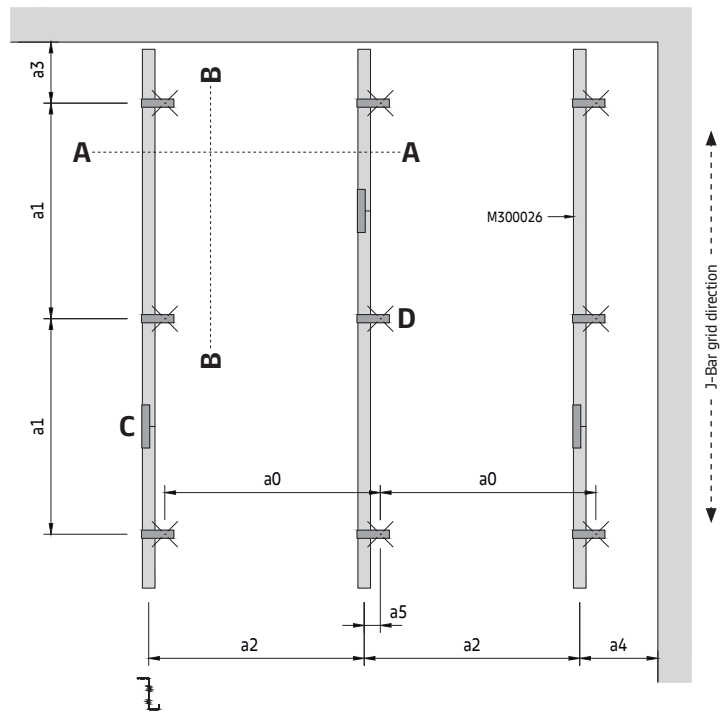

To determine suspension layout

The module length (M) of the requested ceiling is equal to the distance between the DP12 A-Bar centres (a2). On the appropriate spacing table, read down the column headed (a2) to the required module length then read across to determine the suspension point spacing (a0) and direct hanger spacing (a1). The shown values are maximum allowed distances and can be reduced but not exceeded.

METAL R-H 200 / METAL Q-H 100 F
D02.104.2

Detail C

Splice connection

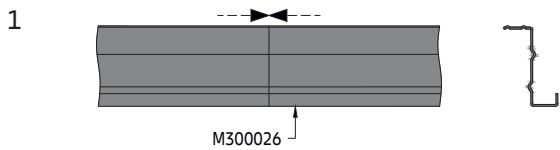

Once the J-Bars are installed, the ends should be brought together without a gap.

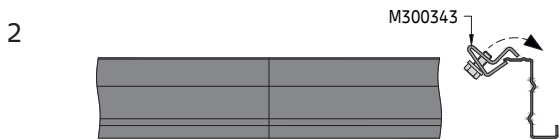

The connectors for the J-Bars must be inserted from above.

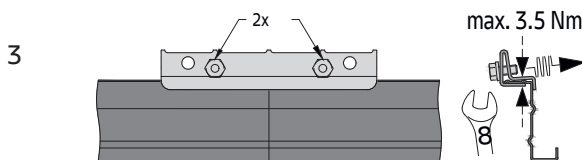

Use the bolts to secure the connector. Stagger the joints.

Detail D

Direct hanger installation

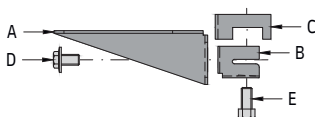

The direct hanger consists of five pre-assembled components (A, B, C, D, E).

METAL Q-H 100 F

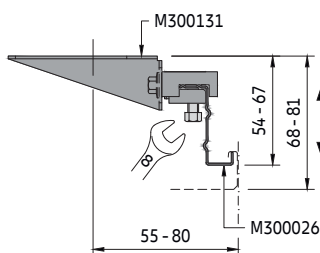

METAL R-H 200

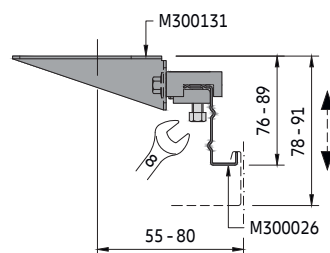

Part A is attached to the soffit first. The distance from the J-Bar to the attachment point must not exceed 70 mm.

Part B is not tightened, so the J-Bar can be inserted horizontally. Tightening the bolts (part D, E) creates a stable connection. Before that, the height should be set up and part C inserted from above. Part C is positioned between part A and B and prevents the J-Bar from falling out of the hanger.

Large METAL R-H 200 panels with a long edge height of 55 mm require a minimum installation height of 83 mm.

Optional installation

METAL Q-H 100 F

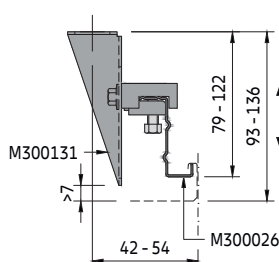

METAL R-H 200

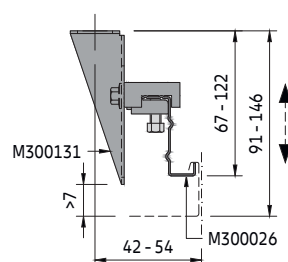

The distance between the J-Bars should be measured exactly, otherwise the tiles / panels are difficult to install and elements could fall out.

The direct hanger can optionally also be installed vertically. To do this, the components must first be disassembled. The shorter side of part A is then attached to the soffit.

METAL R-H 200 / METAL Q-H 100 F

D02.104.2

Detail E (METAL R-H 200)

Panel insertion

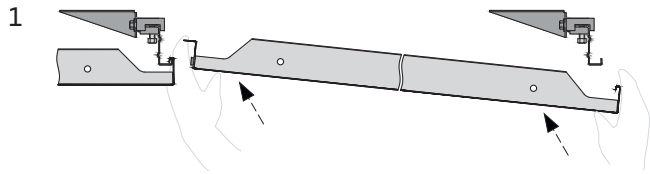

First place the panels with the outward bend short side above the neighbor panel to the left.



Hook-on the opposite side with the hook detail on the J-Bar to the right. The panel will rest now on the neighbor panel to the left and the J-Bar to the right.

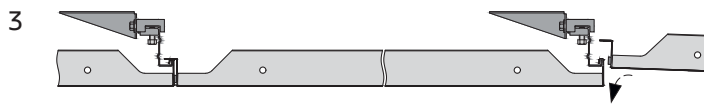

Continue with the next panel.



For METAL Q-H 100 F the sequence is the same.

Panel extraction



With a closed ceiling, any panel can be removed as long as there are no obstacles such as service integrations, etc.

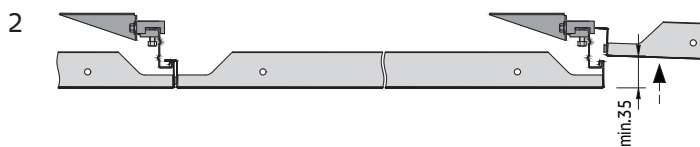

Lift the neighbor panel to the right min. 35 mm (for METAL Q-H 100 F min. 25 mm).

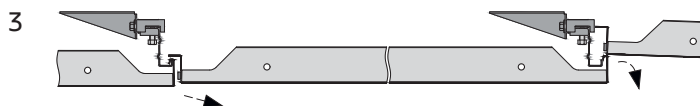

Detach the panel that is to be removed from the J-Bar.

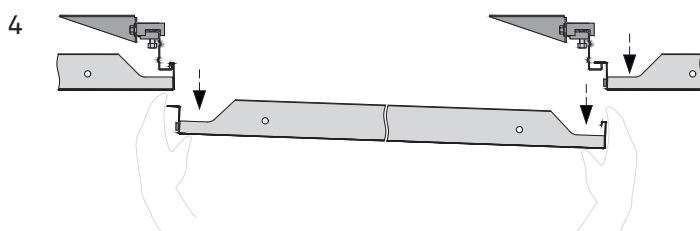

Remove it downwards and store the panel in a safe place so that it cannot be damaged. The neighbor panel will rest again on the J-Bar.

For METAL Q-H 100 F the sequence is the same.

METAL R-H 200 / METAL Q-H 100 F

D02.104.2

Detail F

Optional security clip (unscrewed version) for METAL R-H 200

The security clip serves to secure the panels and prevents them from being removed without the use of the appropriate extraction tool.

Panel installation / locking

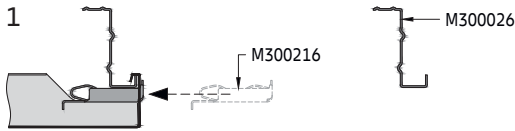

When using the optional security clip, panel by panel is installed and secured immediately. The clip is placed at the crossing point between the panels. Push the clip till it is almost flushing with the edge of the installed panel. One security clip per panel is needed and can only be used for panels with a gap of max. 3 mm.

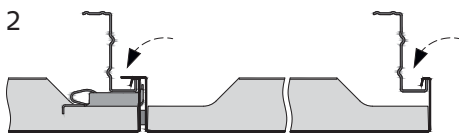

Install the panel.

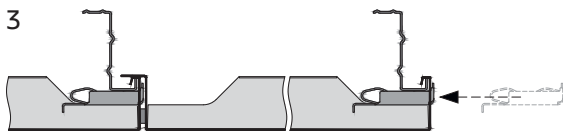

Place the next row of security clips, as described at step 1. Take the extraction tool and push the first clip row to the end position. Insert the extraction tool carefully to avoid damaging the gasket. Follow this row by row, until the ceiling is completely installed and locked.

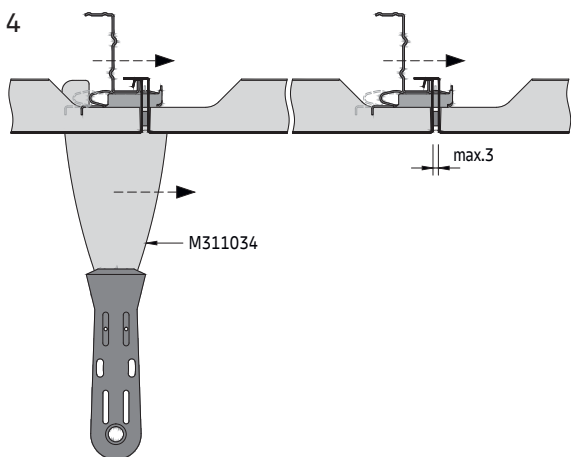

Locked position

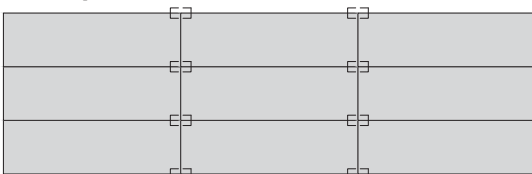

Panel extraction / unlocking

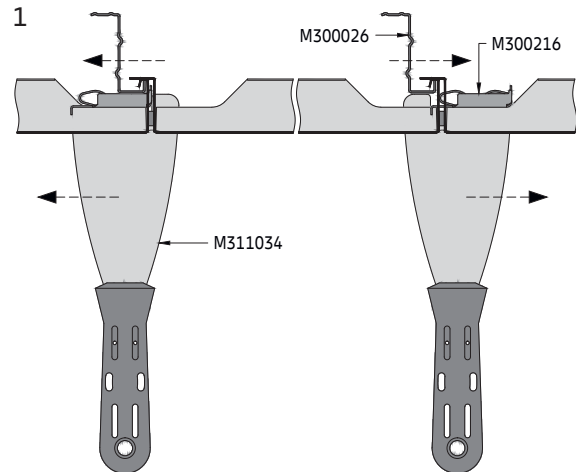

Take the extraction tool and push the four security clips away from the panel to be removed (see layout below). Insert the extraction tool carefully to avoid damaging the gasket. The security clips to the right will jump out and rest on the neighbor panel.

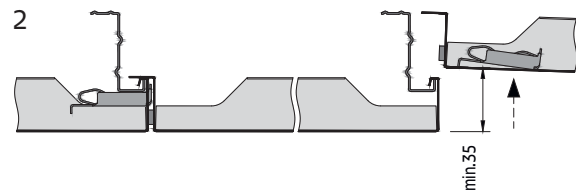

Lift the neighbor panel to the right min. 35 mm.

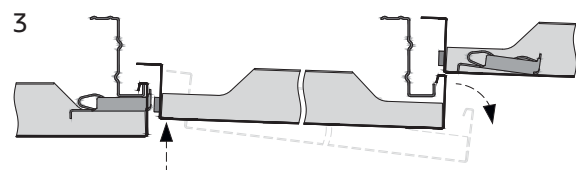

The panel can be extracted downwards, as explained in the panel extraction sequence. In order to install the panel back, the loose security clips are first collected and then installed again, as described to the left.

Unlocked position

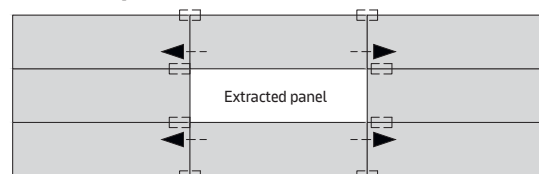

METAL R-H 200 / METAL Q-H 100 F
D02.104.2

Detail G

Optional security bracket (screwed version)

The security bracket serves to secure the panels and prevents them from being removed.

Panel installation / locking for METAL R-H 200

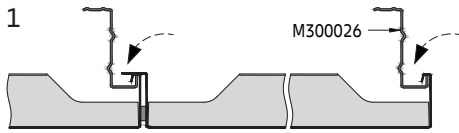

When using the screwed optional security bracket, panel by panel is installed and secured immediately.

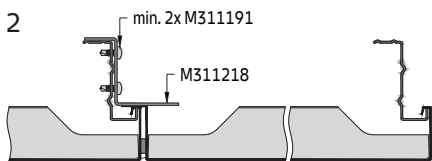

The bracket is placed at the crossing point between the panels. There are two options (A / B) of how the security bracket can be installed. Use at minimum 2 self-drilling screws to fix it. One security bracket per panel is needed.

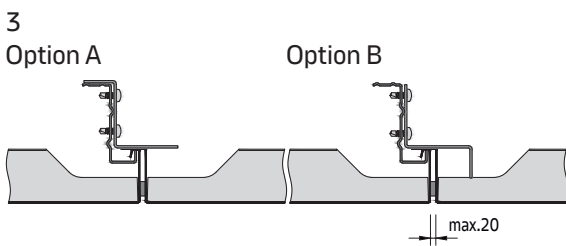

Follow this row by row, until the ceiling is completely installed and locked. The last panel remains unsecured. If panels are to be removed, the ceiling must be opened from the last panel to the desired area.

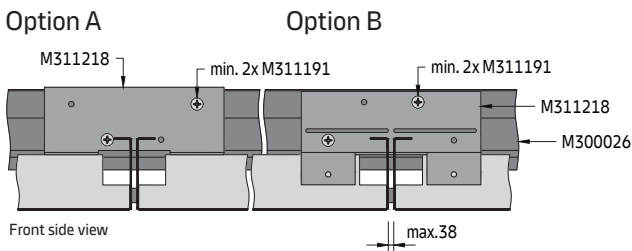

Tile locking for METAL Q-H 100 F

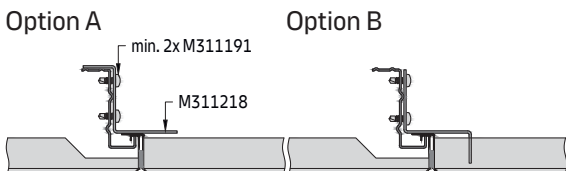

Locked position METAL R-H 200

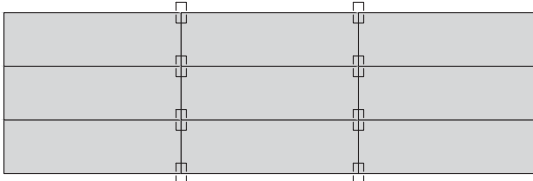

Locked position METAL Q-H 100 F

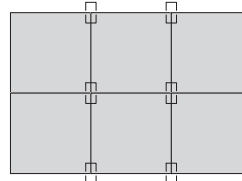

METAL R-H 200 / METAL Q-H 100 F

D02.104.2

Material required per m² (no waste included) METAL R-H 200**System without additional load [pcs/m²]**

Components		a2 [mm]	1200	1600	1800	2000	2400	2800	3100	3300
M300026	J-Bar		0.21	0.16	0.14	0.13	0.10	0.09	0.08	0.08
M300131	Direct hanger for J-Bar		0.56	0.52	0.56	0.63	0.69	0.60	0.54	0.51
M300343	Splice connector for J-Bar		0.21	0.16	0.14	0.13	0.11	0.09	0.09	0.08

Material required per m² (no waste included) METAL Q-H 100 F**System without additional load [pcs/m²]**

Components		a2 [mm]	600	625
M300026	J-Bar		0.42	0.40
M300131	Direct hanger for J-Bar		1.11	1.07
M300343	Splice connector for J-Bar		0.42	0.41

The shown quantities are theoretical and based on an ideal layout, without considering the actual room layout. The ideal layout is based on a calculation of 1.0 x 1.0 m (1.00 m²). This calculation does not allow any damage, spare nor wastage. The final quantities and type of suspension have to be checked before ordering. Soffit and wall fixings by others.

Not including perimeter trims, optional security brackets and extraction tools.



METAL R-H 200
Vårso Tower, Warsaw, Poland
© Szymon Polański

METAL R-H 215

U-Profile primary grid + H-Profile 35 secondary grid
Concealed grid solution for indoor applications

General information

- Concealed hook-on grid system for medium and large rooms
- For perpendicular installation on U-Profile primary grid
- H-Profile 35 made of aluminium
- Typical ceiling weight 7.5 - 9.0 kg/m² (indicative value for unperforated panels, without additional load)
- Panels are easily installed and fully demountable
- Optional security clip available
- Swing-down service ACCESS opening panel option
- Seismic design application available, separate document

Isometric view

Perimeter solutions on separate datasheet.

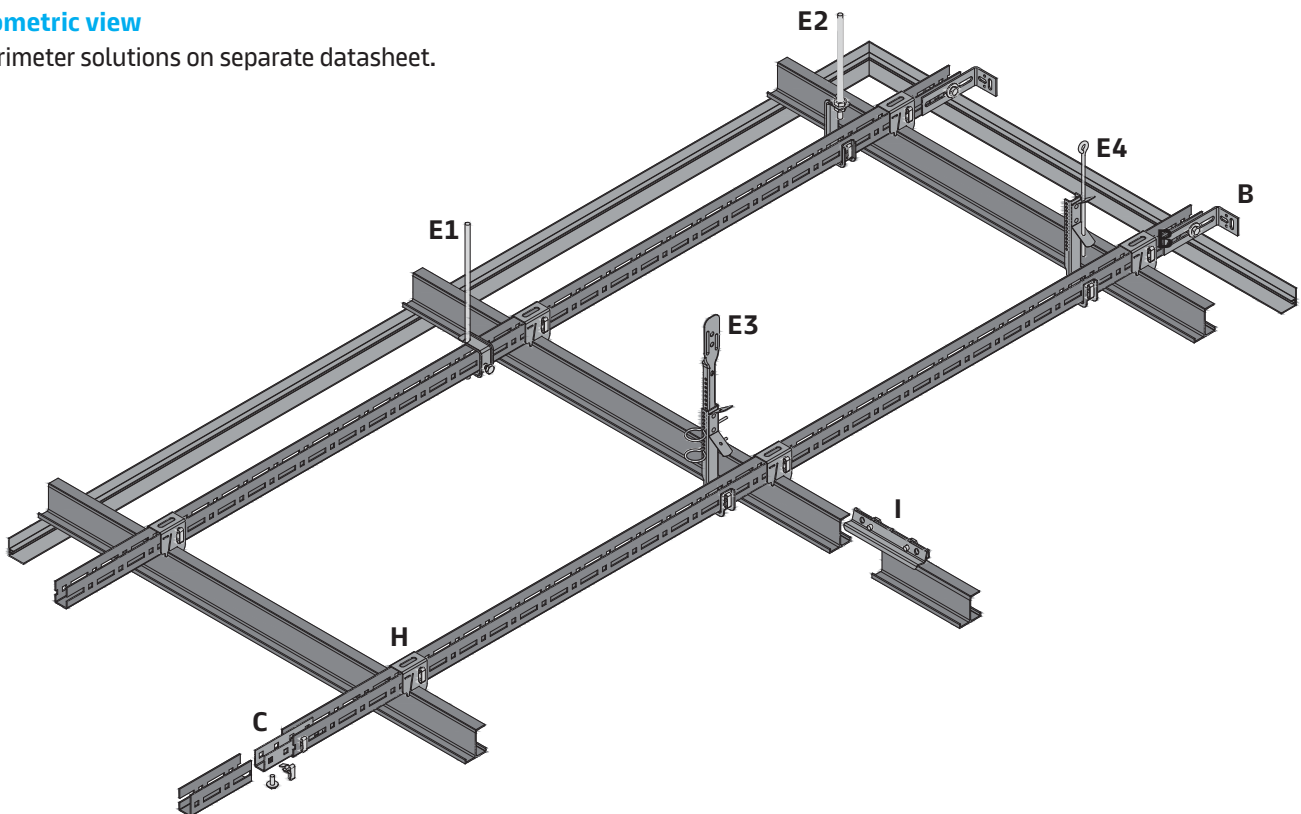

Vario Design, creative & bespoke layout options

Vario Design

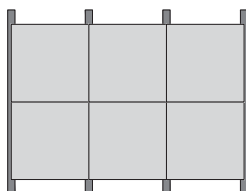
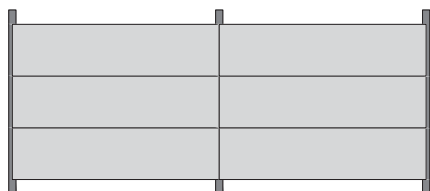

Creative

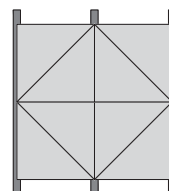

Bespoke (on request)

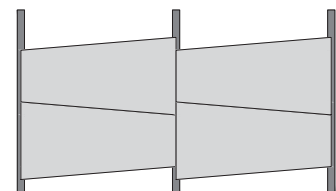

Section F

Example with suspension option E1

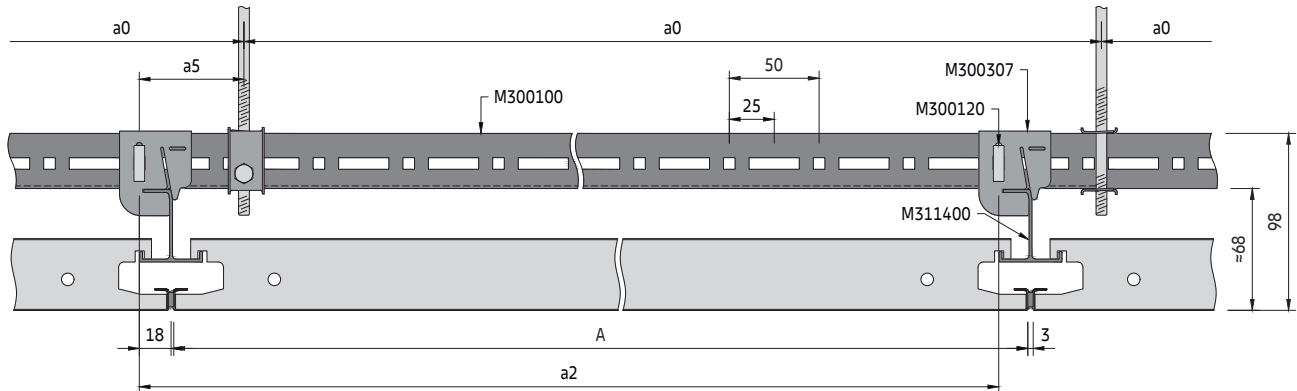

Section G

Example with suspension option E1

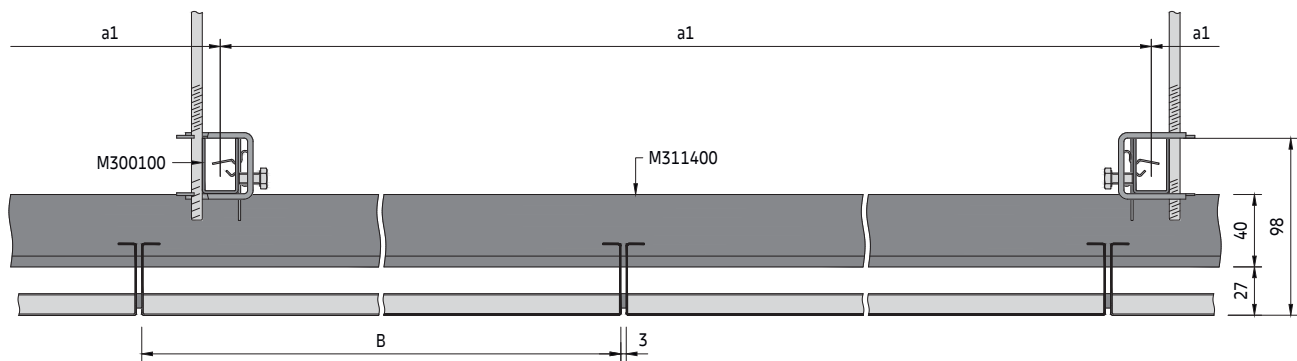

Panels supplied as standard with a 3 mm gasket on one long and one short side to improve the visual appearance. Optionally panels can be installed without a gasket.

Secondary grid components

Standard components

- M311400 H-Profile 35
- M300343 Connector for H-Profile 35
- M300307 Hanger for H-Profile 35
- M300120 Plug-in clip

Optional components

- M300235 Security bracket
- M311034 Extraction tool
- M900000 Black gasket 8x3 mm (spare roll)

See U-Profile primary grid for primary grid components

H-Profile 35 secondary grid

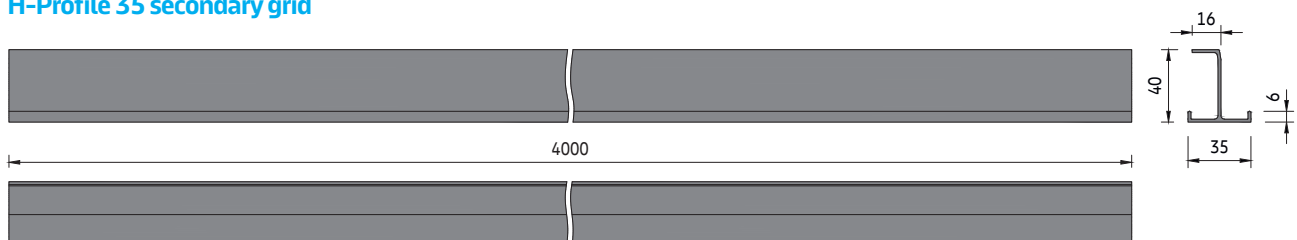

Spacing

a2 [mm]	System without additional load		System with additional load +4 kg/m²	
	a0 [mm]	a1 [mm]	a0 [mm]	a1 [mm]
600	1200	1900	1200	1750
650	1300	1900	1300	1550
700	1400	1850	1400	1300
750	1500	1800	750	1600
800	1600	1550	800	1550
850	1700	1350	850	1500
900	900	1650	900	1450
950	950	1600	950	1400
1000	1000	1550	1000	1400
1050	1050	1500	1050	1350
1100	1100	1500	1100	1300
1150	1150	1450	1150	1300
1200	1200	1400	1200	1250
1250	1250	1400	1250	1250
1300	1300	1350	1300	1200
1350	1350	1350	1350	1200
1400	1400	1300	1400	1150
1450	1450	1300	1450	1150
1500	1500	1250	1500	1150
1550	1550	1250	1550	1100
1600	1600	1250	1600	1000
1650	1650	1200	1650	950
1700	1700	1200	1700	900
1750	1750	1150	1750	800
1800	1800	1150	1800	750
1850	1850	1050	1850	650
1900	1900	950	1900	600
1950	975	1100	975	1000
2000	1000	1100	1000	1000
2050	1025	1100	1025	950
2100	1050	1050	1050	950
2150	1075	1050	1075	950
2200	1100	1050	1100	950
2250	1125	1050	1125	900
2300	1150	1050	1150	900
2350	1175	1000	1175	900
2400	1200	1000	1200	900
2450	1225	1000	1225	900
2500	1250	950	1250	850
2600	1300	950	1300	850
2700	1350	950	1350	850
2800	1400	900	1400	800
2900	1450	900	1450	800
3000	1500	900	1500	800
3100	1550	850	1550	750
3200	1600	850	1600	750
3300	1650	850	1650	750
3300	3300	600	3300	400

Parameters

- a0 Distance between U-Profile suspension points = max. 1900 mm
- a1 Max. distance between U-Profiles
- a2 Distance between H-Profiles 35 = panel length + gasket
- a3 Distance from wall = max. 200 mm
- a4 Distance from wall = max. panel length
- a5 Distance from U-Profile suspension point to hanger = max. 100 mm
- M Module size = panel length + gasket / panel width + gasket
- A Panel length = min. 600 / max. 3300 mm
- B Panel width = min. 247 / max. 1350 mm

Typical grid layout

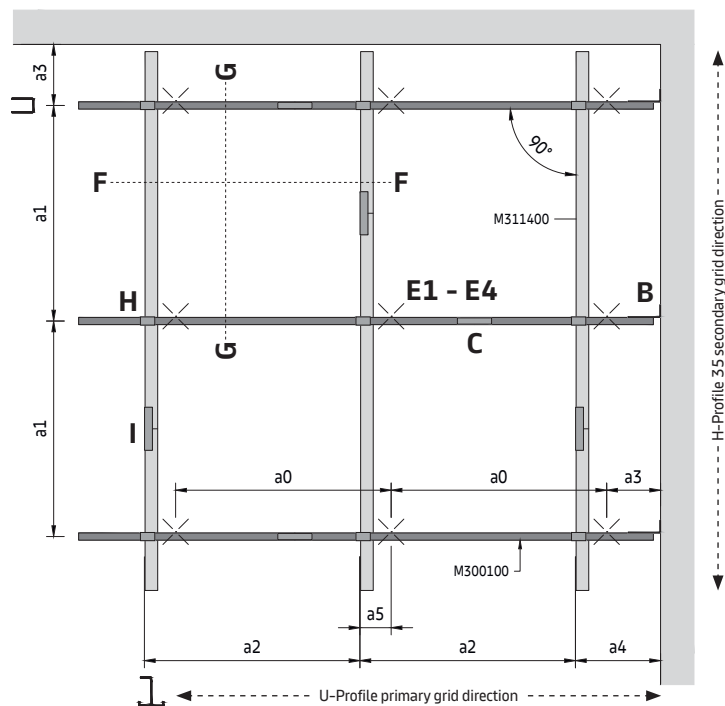

To determine suspension layout

The module length (M) of the requested ceiling is equal to the distance between the H-Profile 35 centres (a2).

On the appropriate spacing table, read down the column headed (a2) to the required module length then read across to determine the suspension point spacing (a0) and U-Profile spacing (a1).

The shown values are maximum allowed distances and can be reduced but not exceeded.

METAL R-H 215

D02.105

Detail H

Hanger installation

- 1

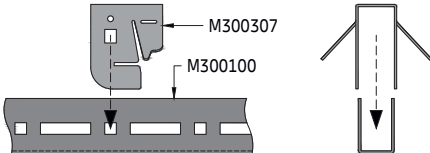

Place the hanger on the U-profile.

- 2

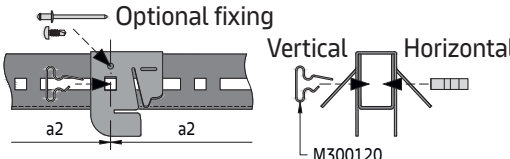

Optional fixing

Vertical Horizontal

M300120

a2 a2

Fix hanger with plug-in clips at the specified module spacing (option A or B). If the panel size does not fit with the modulation of the U-Profile (25 mm increments), the plug-in clip needs to be inserted into a long hole. The hanger position can alternatively be fixed by using a pop-rivet or self-drilling screw.

- 3

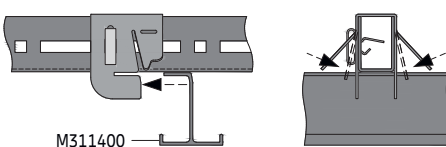

M311400

Insert the H-profile 35 into the hanger, press down the two hanger wings and lock the position of the H-Profile 35.

- 4

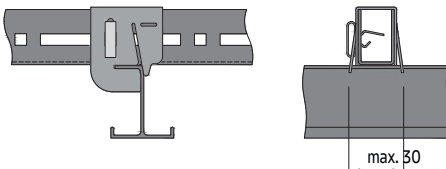

max. 30

The H-Profile 35 is now locked in position.

Detail I

Connector installation

- 1

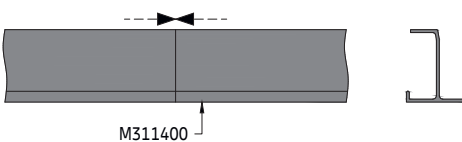

M311400

Once the H-Profiles 35 are installed under the U-Profiles, the ends should be brought together without a gap.

- 2

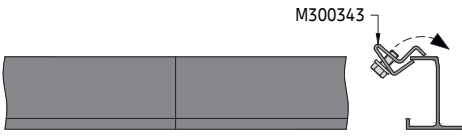

M300343

The connectors for the H-Profile 35 must be inserted from above.

- 3

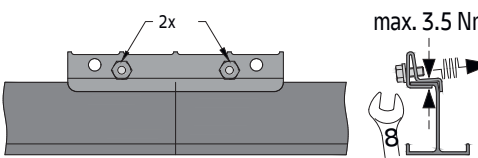

2x

max. 3.5 Nm

Use the bolts to secure the connector. Stagger the joints.

Detail J

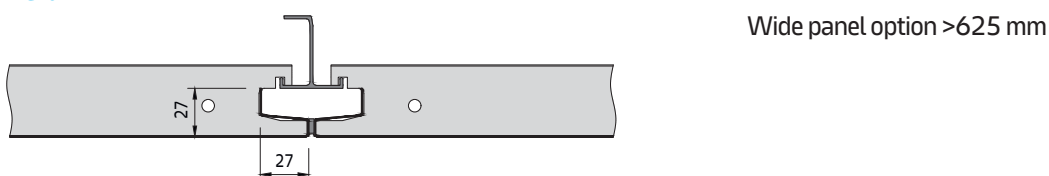

Detail K

Panel insertion

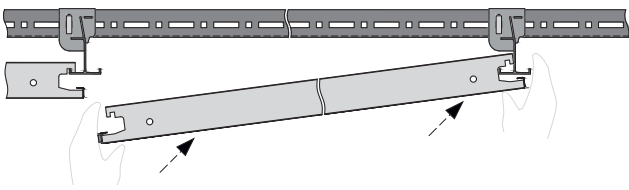
- 1 

First hang the panels with the two hooks at one end.

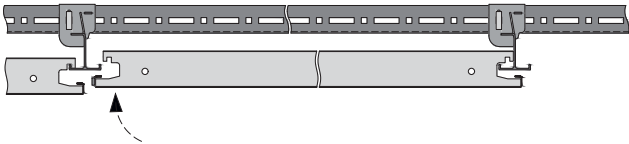
- 2 

Lift the opposite end of the panel to a horizontal position.

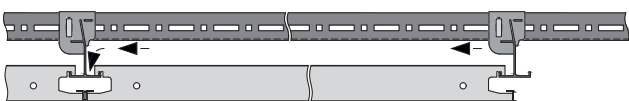
- 3 

Now hang the opposite end of the panel with the hooks.

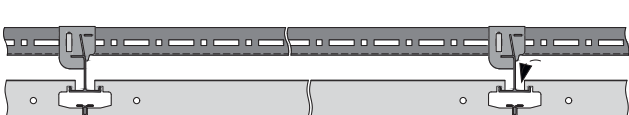
- 4 

Make sure that all four hooks on the panel are hooked on to the H-Profiles 35.

Panel extraction

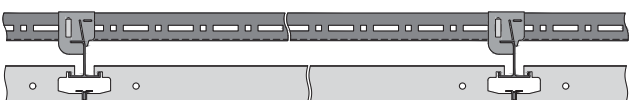
- 1 

With a closed ceiling, any panel can be removed as long as there are no obstacles such as service integrations, etc.

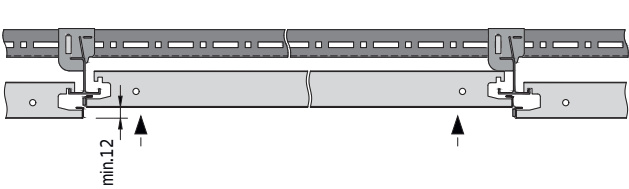
- 2 

Lift the panel min. 12 mm.

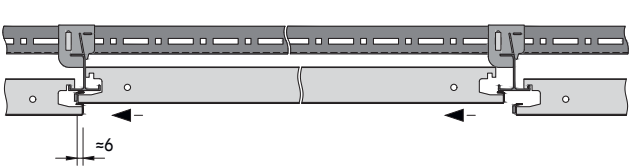
- 3 

Slide it horizontally lengthwise (to the left or right) so that the end fits between the next panel and the H-Profile 35.

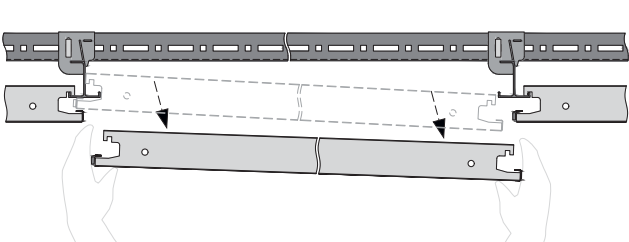
- 4 

Remove it downwards and store the panel in a safe place so that it cannot be damaged.

METAL R-H 215

D02.105

Detail L

Optional security clip

The security clip serves to secure the panels and prevents them from being removed without the use of the appropriate extraction tool.

1

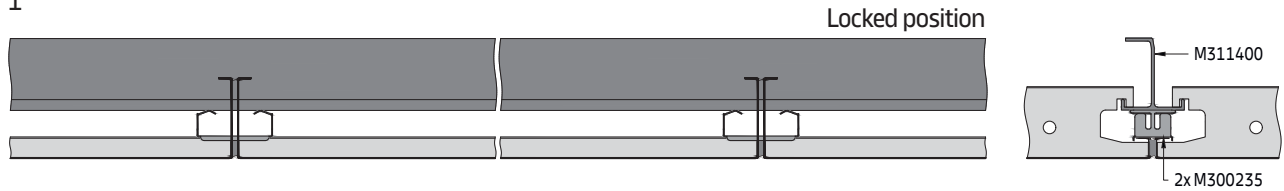

The clip is placed at the crossing point between the panels. One security clip per panel is needed and can only be used for panels with a width up to 625 mm.

2

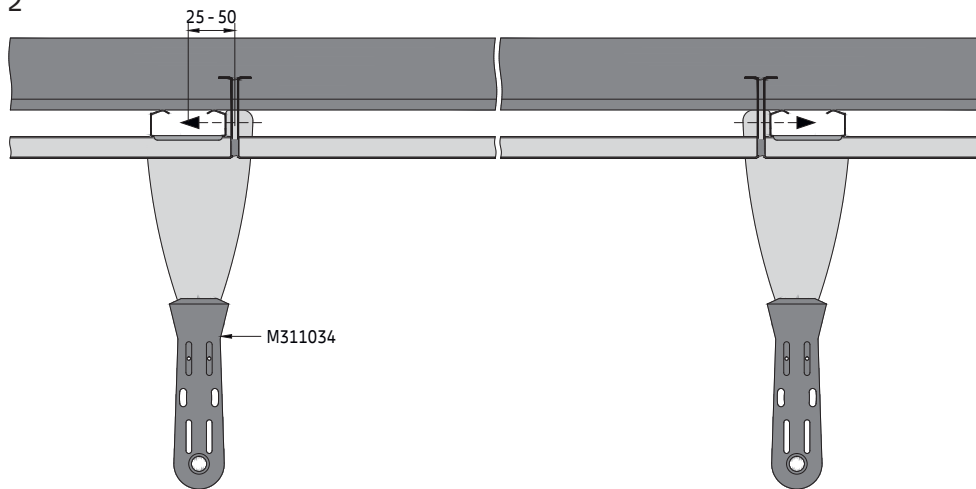

Unlock the panel, by sliding the security clip about 25 - 50 mm above the panels to the left and right. The appropriate extraction tool must be used. Be careful to not damage the gasket.

3

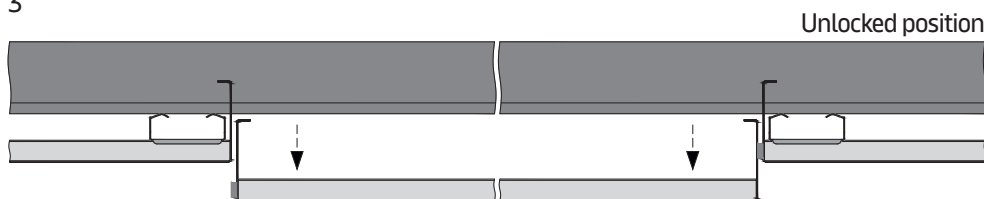

The panel can be extracted downwards, as explained in the panel extraction sequence.

Locked position

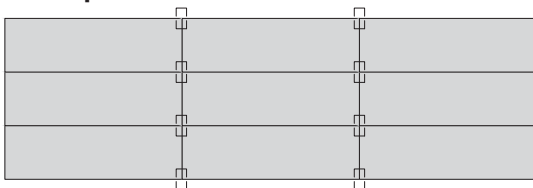

Unlocked position

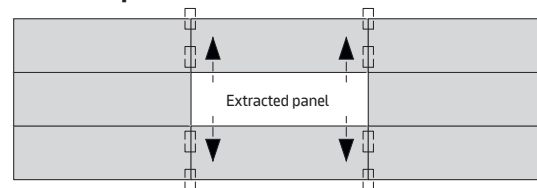

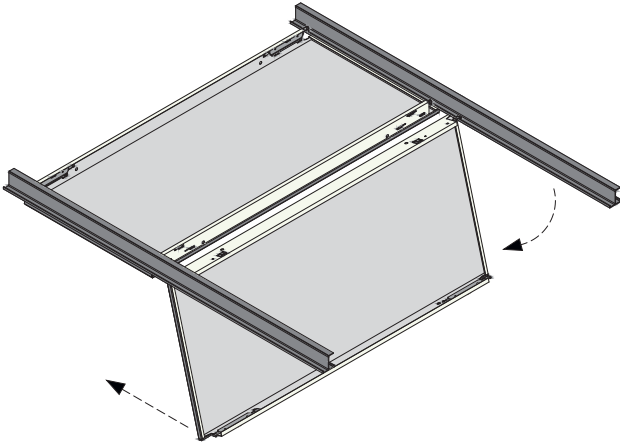
Detail M**METAL R-H 215 HATCH (service access opening)**

METAL R-H 215 HATCH is a solution for service openings. Individual panels or the entire ceiling can be finished with METAL R-H 215 HATCH. Use the appropriate extraction tool to release the brackets on the panel. Swing the panel down carefully. The panels swing-down from the long side. This solution is intended for service access purposes only. The panels must not support any additional load, as this could damage them.

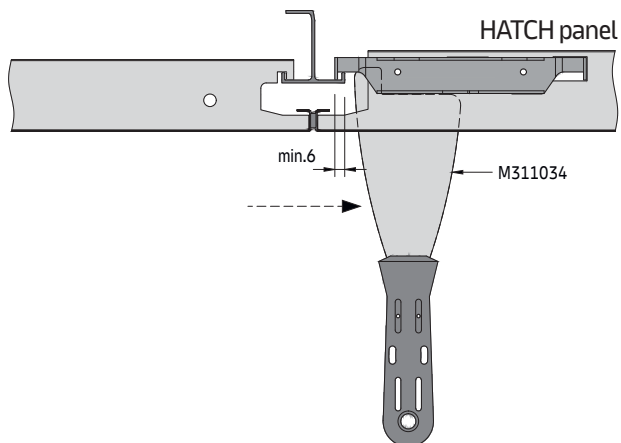

METAL R-H 215 HATCH panels only available with a 3 mm gasket on the long and short side.

METAL R-H 215

D02.105

Material required per m² (no waste included) METAL R-H 200
System without additional load [pcs/m²]

Components		a2 [mm]	1200	1600	1800	2000	2400	2800	3100	3300
M300100	U-Profile		0.19	0.21	0.23	0.24	0.27	0.30	0.31	0.31
M300119	Connector for U-Profile		0.20	0.21	0.24	0.25	0.27	0.30	0.32	0.32
M300120	Plug-in clip		1.00	0.97	0.97	0.96	0.96	1.00	1.02	1.00
M300140	Wall anchor		0.08	0.08	0.09	0.10	0.11	0.12	0.12	0.12
M300307	Hanger for H-Profile 35		0.60	0.55	0.49	0.46	0.42	0.40	0.38	0.36
M300343	Connector for H-Profile 35		0.21	0.18	0.14	0.13	0.11	0.09	0.09	0.08
M311103	Hexagonal nut M6		0.10	0.10	0.10	0.10	0.12	0.12	0.12	0.12
M311105	Washer		0.10	0.10	0.10	0.10	0.12	0.12	0.12	0.12
M311303	Hexagonal bolt M6 x 16 mm		0.10	0.10	0.10	0.10	0.12	0.12	0.12	0.12
M311400	H-Profile 35		0.21	0.18	0.14	0.13	0.11	0.09	0.08	0.08
Various	Suspension points (E1 - E4)		0.60	0.55	0.49	0.91	0.84	0.80	0.76	0.72

The shown quantities are theoretical and based on an ideal layout, without considering the actual room layout. The ideal layout is based on a calculation of 10 x 10 m (100 m²). This calculation does not allow any damage, spare nor wastage. The final quantities and type of suspension have to be checked before ordering. Soffit and wall fixings by others.

Not including perimeter trims, optional security brackets and extraction tools.

METAL R-H 215

Direct suspended H-Profile 35
Concealed grid solution for indoor applications

General information

- Concealed hook-on grid system for small rooms with low cavity
- For perpendicular installation
- H-Profile 35 made of aluminium
- Typical ceiling weight 7.0 - 8.5 kg/m² (indicative value for unperforated panels, without additional load)
- Panels are easily installed and fully demountable
- Security option available
- Swing-down service ACCESS opening panel option

Isometric view

Perimeter solutions on separate datasheet.

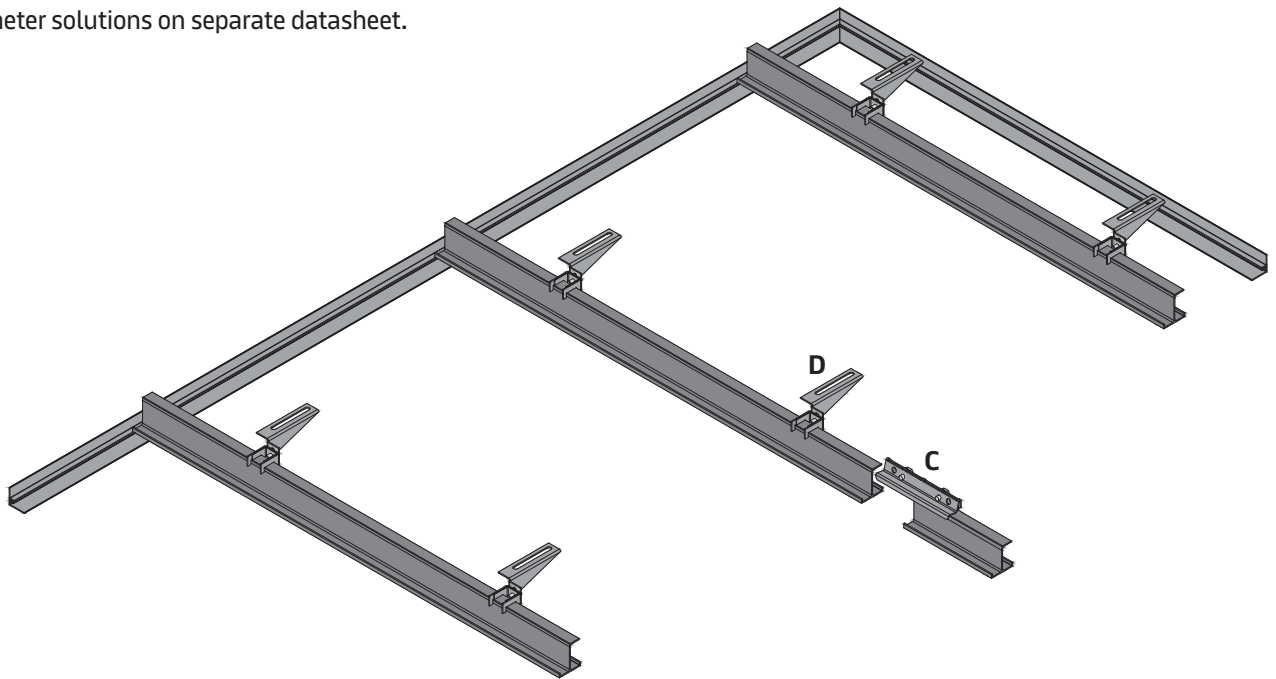

The use of a primary grid system is recommended, as this simplifies levelling and the alignment of the ceiling.

Vario Design, creative & bespoke layout options

Vario Design

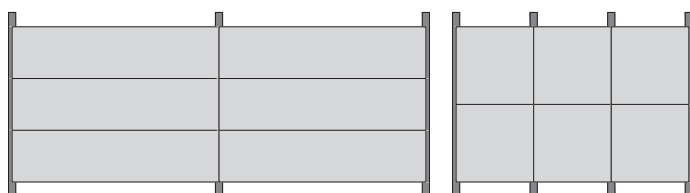

Creative

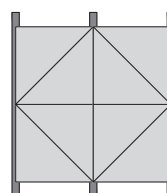

Bespoke (on request)

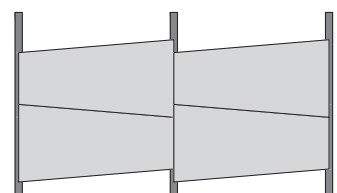

Section A

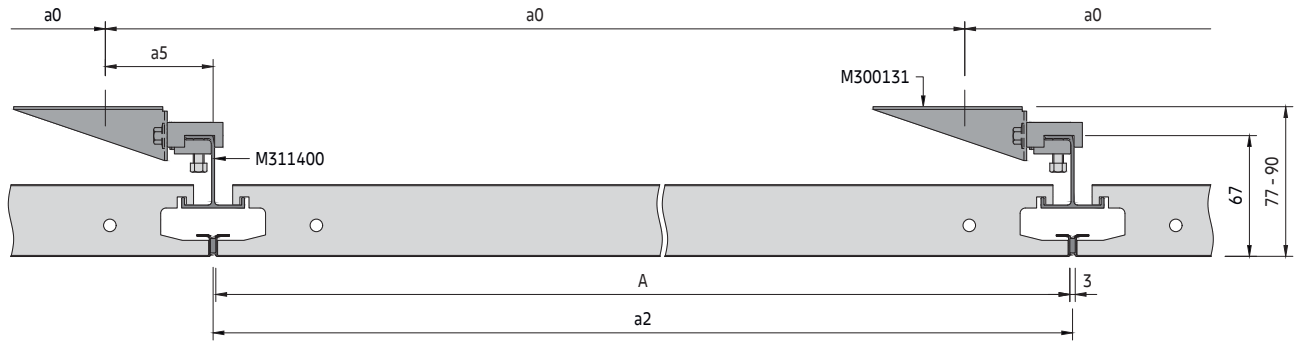

Section B

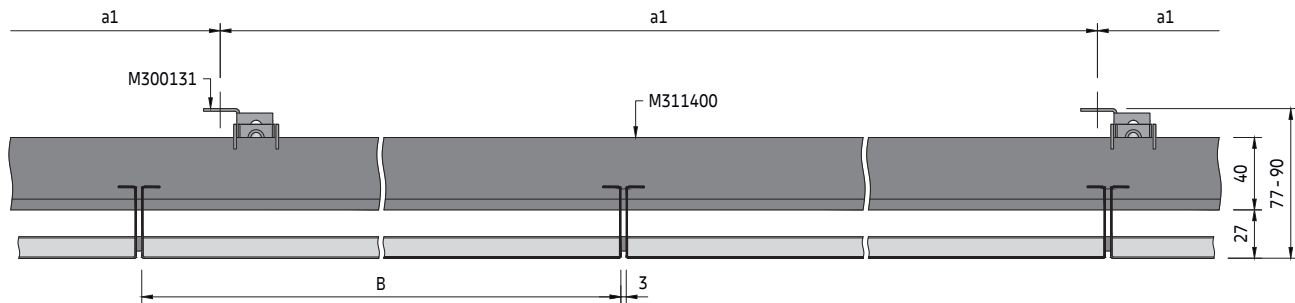

Panels supplied as standard with a 3 mm gasket on one long and one short side to improve the visual appearance. Optionally panels can be installed without a gasket.

Secondary grid components

Standard components

- M311400 H-Profile 35
- M300343 Splice connector for H-Profile 35
- M300131 Direct hanger for H-Profile 35

Optional components

- M300235 Security clip
- M311034 Extraction tool
- M900000 Black gasket 8x3 mm (spare roll)

H-Profile 35

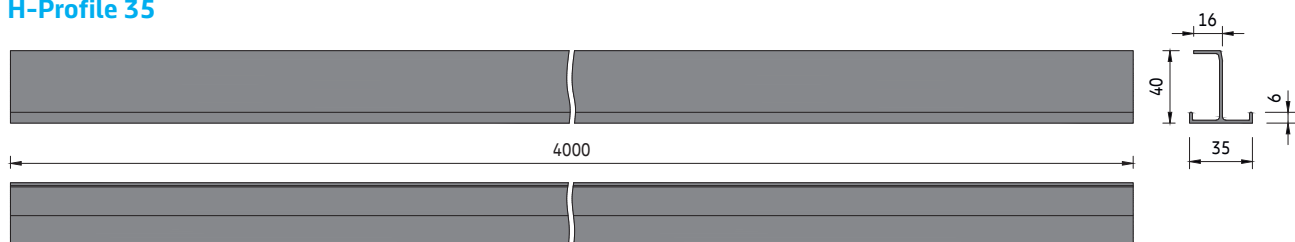

Spacing

a2 [mm]	System without additional load		System with additional load +4 kg/m²	
	a0 [mm]	a1 [mm]	a0 [mm]	a1 [mm]
600	600	1500	600	1500
650	650	1500	650	1500
700	700	1500	700	1500
750	750	1500	750	1500
800	800	1500	800	1500
850	850	1500	850	1500
900	900	1500	900	1500
950	950	1500	950	1500
1000	1000	1500	1000	1500
1050	1050	1500	1050	1500
1100	1100	1500	1100	1500
1150	1150	1500	1150	1200
1200	1200	1500	1200	1200
1250	1250	1500	1250	1200
1300	1300	1500	1300	1200
1350	1350	1500	1350	1200
1400	1400	1500	1400	1200
1450	1450	1200	1450	1200
1500	1500	1200	1500	1000
1550	1550	1200	1550	1000
1600	1600	1200	1600	1000
1650	1650	1200	1650	800
1700	1700	1200	1700	800
1750	1750	1200	1750	800
1800	1800	1000	1800	600
1850	1850	1000	1850	600
1900	1900	800	1900	600
1950	1950	800	1950	600
2000	2000	800	2000	600
2050	2050	800	2050	600
2100	2100	800	2100	600
2150	2150	800	2150	600
2200	2200	800	2200	600
2250	2250	800	2250	400
2300	2300	800	2300	400
2350	2350	600	2350	400
2400	2400	600	2400	400
2450	2450	600	2450	400
2500	2500	600	2500	400
2600	2600	600	2600	400
2700	2700	600	2700	400
2800	2800	600	2800	400
2900	2900	600	2900	400
3000	3000	600	3000	400
3100	3100	600	3100	400
3200	3200	600	3200	400
3300	3300	600	3300	400

Parameters

- a0 Distance between H-Profile 35 suspension points = max. 1900 mm
- a1 Max. distance between direct hangers
- a2 Distance between H-Profiles 35 = panel length + gasket
- a3 Distance from wall = max. 200 mm
- a4 Distance from wall = max. panel length
- a5 Distance panel joint and top fixing = max. 70 mm
- M Module size = panel length + gasket / panel width + gasket
- A Panel length = min. 600 / max. 3300 mm
- B Panel width = min. 247 / max. 1350 mm

Typical grid layout

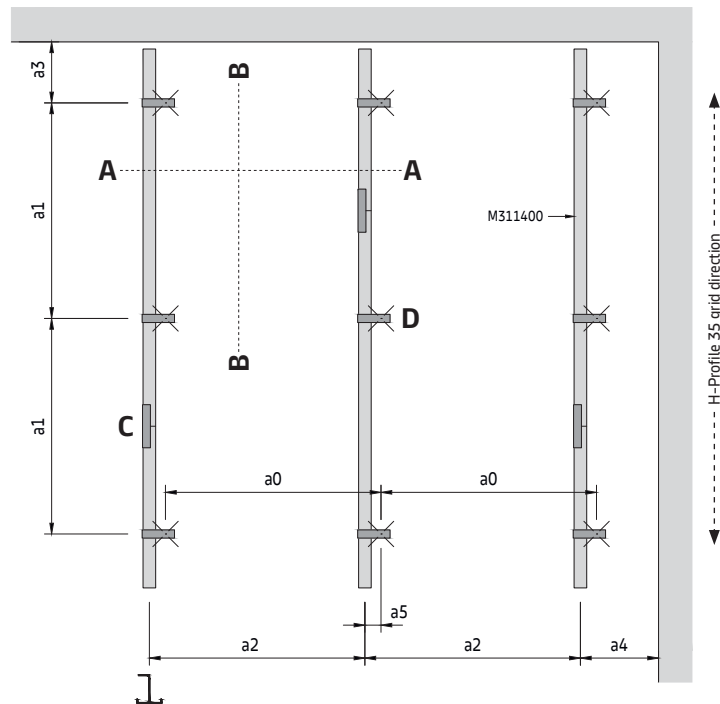

To determine suspension layout

The module length (M) of the requested ceiling is equal to the distance between the DP12 A-Bar centres (a2).

On the appropriate spacing table, read down the column headed (a2) to the required module length then read across to determine the suspension point spacing (a0) and direct hanger spacing (a1).

The shown values are maximum allowed distances and can be reduced but not exceeded.

Detail C

Splice connection

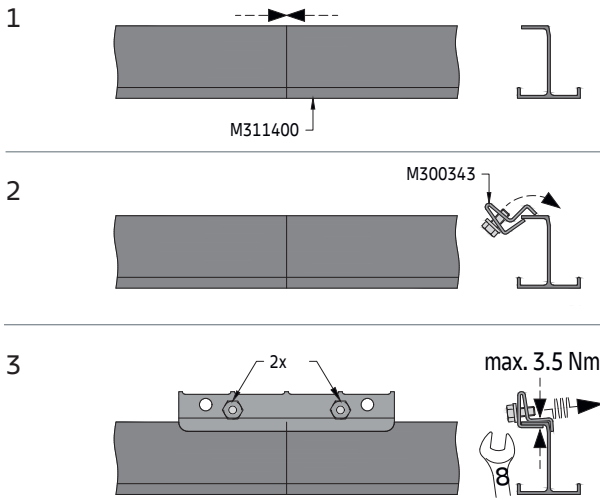

Once the H-Profiles 35 are installed, the ends should be brought together without a gap.

The connectors for the H-Profile 35 must be inserted from above.

Use the bolts to secure the connector. Stagger the joints.

Detail D

Direct hanger installation

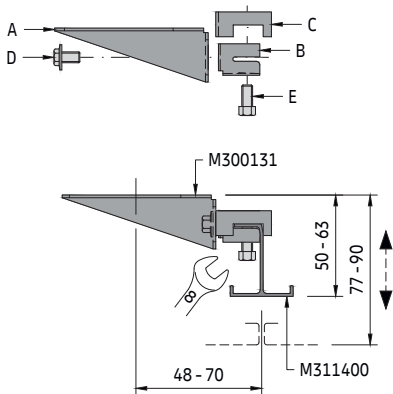

The direct hanger consists of five pre-assembled components (A, B, C, D, E).

Part A is attached to the soffit first. The distance from the H-Profile 35 to the attachment point must not exceed 70 mm.

Part B is not tightened, so the H-Profile 35 can be inserted horizontally. Tightening the bolts (part D, E) creates a stable connection. Before that, the height should be set up and part C inserted from above. Part C is positioned between part A and B and prevents the H-Profile 35 from falling out of the hanger.

Optional installation

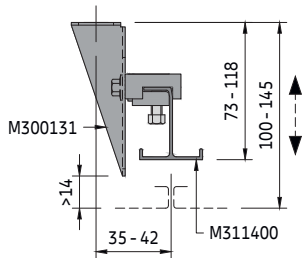

The distance between the H-Profiles 35 should be measured exactly, otherwise the panels are difficult to install and elements could fall out.

The direct hanger can optionally also be installed vertically. To do this, the components must first be disassembled. The shorter side of part A is then attached to the soffit.

Detail E

Wide panel option > 625 mm

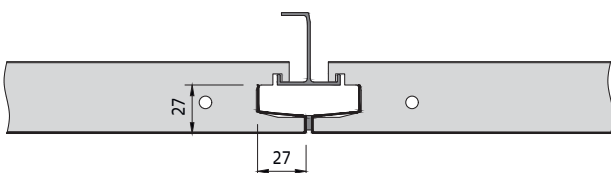

Detail F

Panel insertion

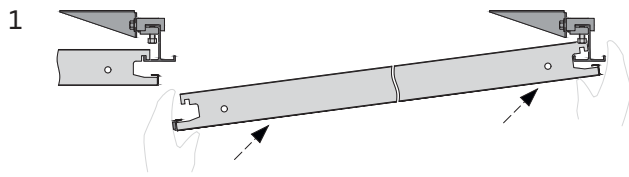

First hang the panels with the two hooks at one end.

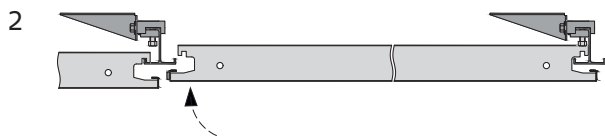

Lift the opposite end of the panel to a horizontal position.



Now hang the opposite end of the panel with the hooks.



Make sure that all four hooks on the panel are hooked onto the H-Profiles 35.

Panel extraction



With a closed ceiling, any panel can be removed as long as there are no obstacles such as service integrations, etc.

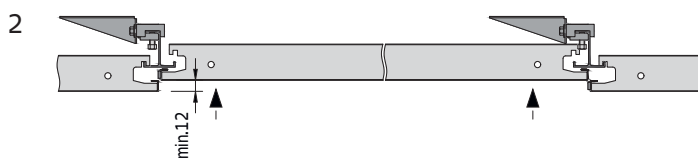

Lift the panel min. 12 mm.

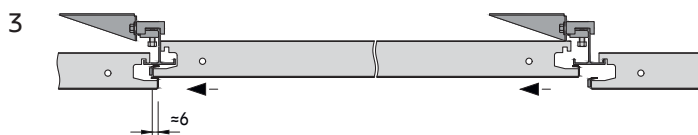

Slide it horizontally lengthwise (to the left or right) so that the end fits between the next panel and the H-Profile 35.

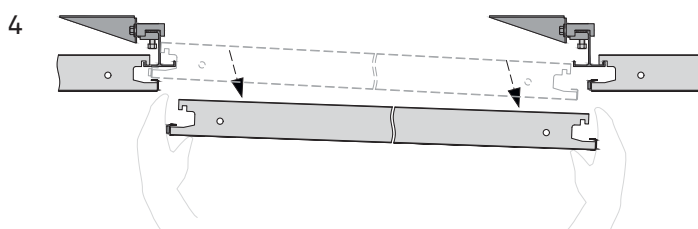

Remove it downwards and store the panel in a safe place so that it cannot be damaged.

METAL R-H 215

D02.105.1

Detail G

Optional security clip

The security clip serves to secure the panels and prevents them from being removed without the use of the appropriate extraction tool.

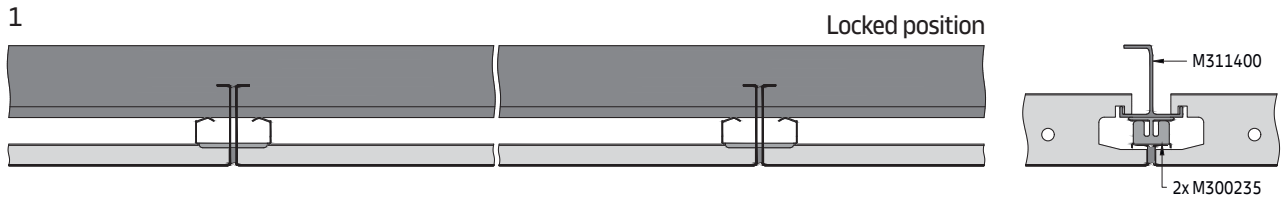

The clip is placed at the crossing point between the panels. One security clip per panel is needed and can only be used for panels with a width up to 625 mm.

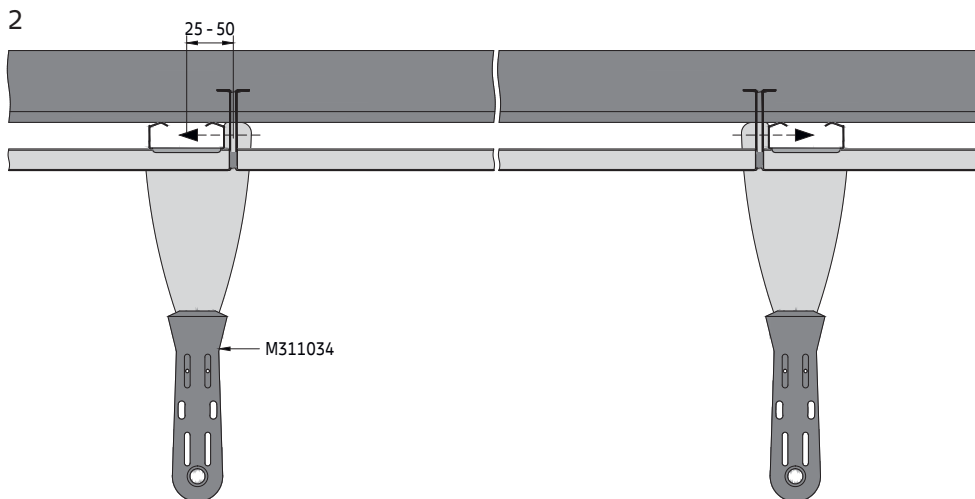

Unlock the panel, by sliding the security clips about 25 - 50 mm above the panels to the left and right. The appropriate extraction tool must be used. Be careful to not damage the gasket.

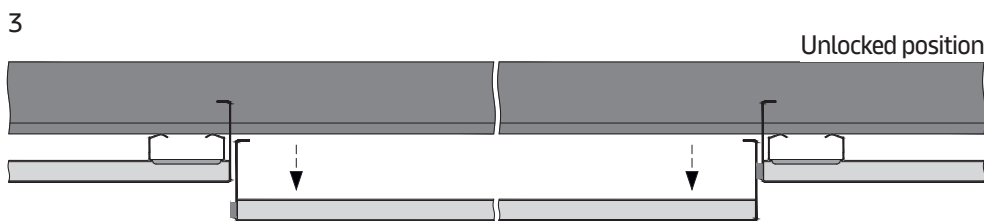

The panel can be extracted downwards, as explained in the panel extraction sequence.

Locked position

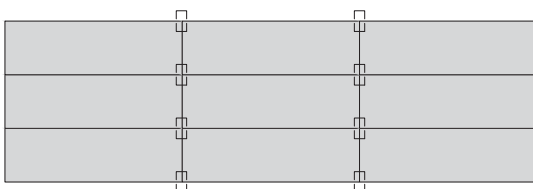

Unlocked position

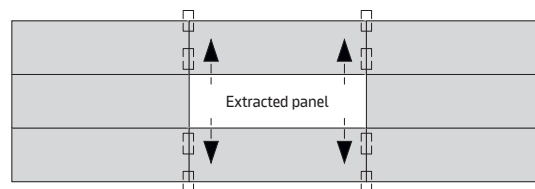

Detail H

METAL R-H 215 HATCH (service access opening)

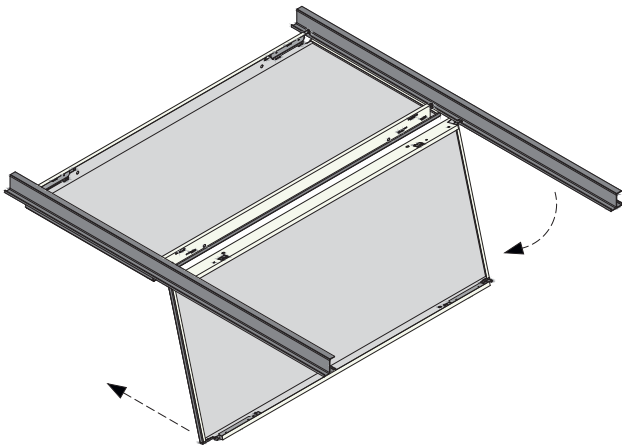

METAL R-H 215 HATCH is a solution for service openings. Individual panels or the entire ceiling can be finished with METAL R-H 215 HATCH.

Use the extraction tool to release the brackets on the panel. Swing the panel down carefully. The panels swing-down from the long side.

This solution is intended for service access purposes only. The panels must not support any additional load, as this could damage them.

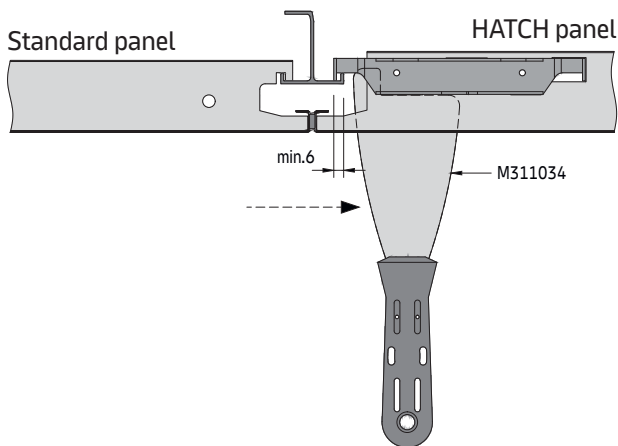

METAL R-H 215 HATCH panels are only available with 3 mm gasket on the long and both short side.

Material required per m² (no waste included)
System without additional load [pcs/m²]

Components		a2 [mm]	1200	1600	1800	2000	2400	2800	3100	3300
M300131	Direct hanger for H-Profile 35		0.56	0.52	0.56	0.63	0.69	0.60	0.54	0.51
M300343	Splice connector for H-Profile 35		0.21	0.18	0.14	0.13	0.11	0.09	0.09	0.08
M311400	H-Profile 35		0.21	0.18	0.14	0.13	0.11	0.09	0.08	0.08

The shown quantities are theoretical and based on an ideal layout, without considering the actual room layout. The ideal layout is based on a calculation of 10 x 10 m (100 m²). This calculation does not allow any damage, spare nor wastage. The final quantities and type of suspension have to be checked before ordering. Soffit and wall fixings by others.

Not including perimeter trims, optional security clips and extraction tools.



METAL R-H 215
Masaryk University, Brno, Czech Republic
© U1

METAL R-H 220 / METAL Q-H 120 F

Swiss market only

U-Profile primary grid + H-Profile 28 secondary grid
Concealed grid solution for indoor applications

General information

- Concealed hook-on grid system for medium and large rooms (METAL R-H 220), small and medium rooms (METAL Q-H 120 F)
- For perpendicular installation on U-Profile primary grid
- H-Profile 28 made of aluminium
- Typical ceiling weight 7.5 – 9.0 kg/m² (METAL R-H 220), 5.5 kg/m² (METAL Q-H 120 F) (indicative value for unperforated panels, without additional load)
- Panels are easily installed and fully demountable
- Security option available (METAL R-H 220)

Isometric view

Select the suspension option E1 - E4.
Perimeter solutions on separate datasheet.

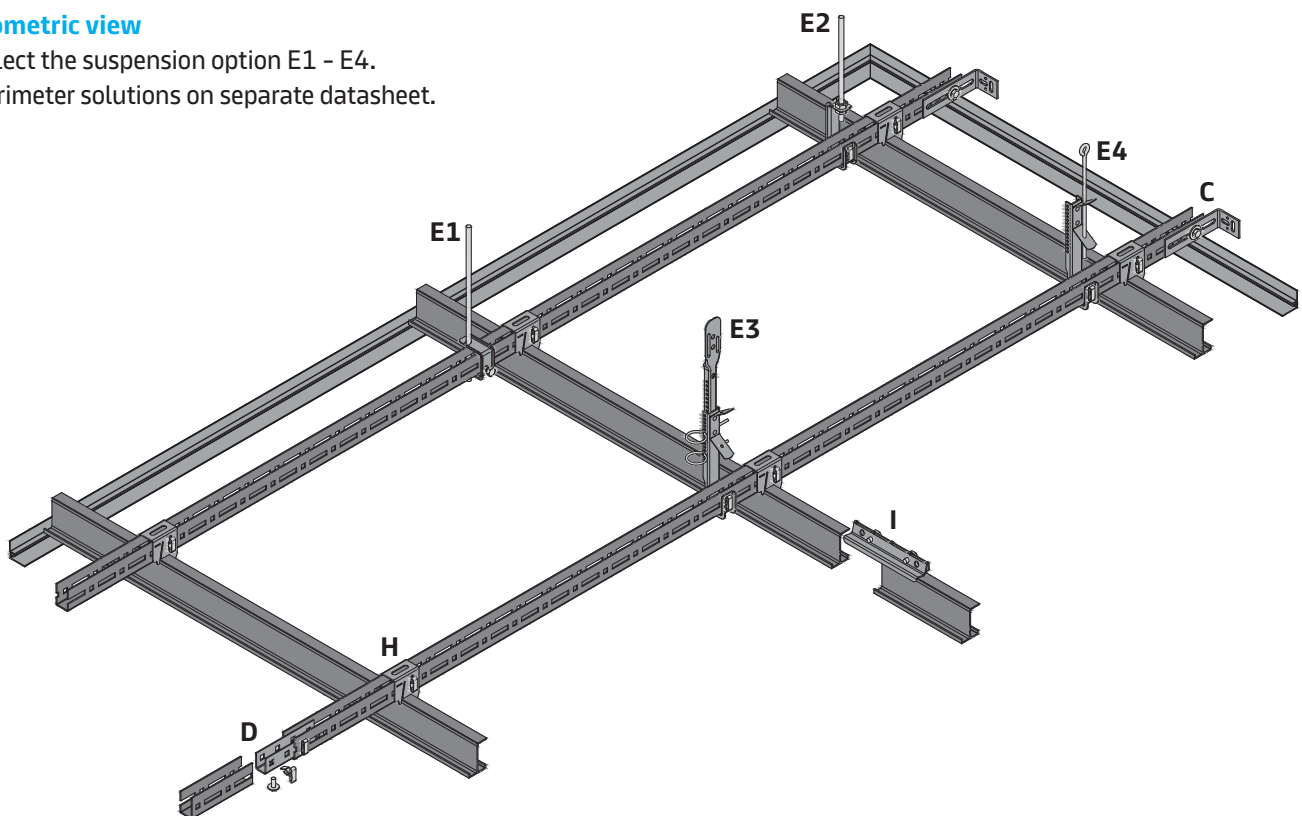

Standard & Vario Design layout options

Standard

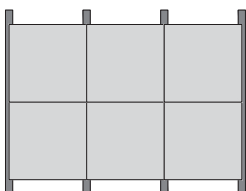

Vario Design

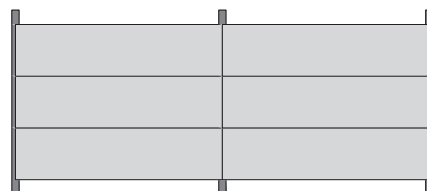

METAL R-H 220 / METAL Q-H 120 F
D02.106

Section F (METAL R-H 220)

Example with suspension option E1

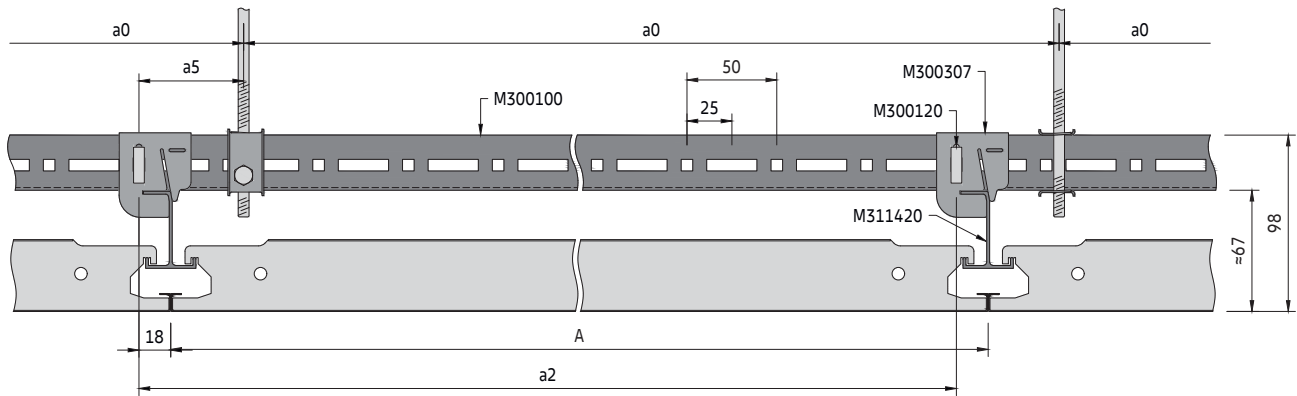

Section F (METAL Q-H 120 F)

Example with suspension option E1

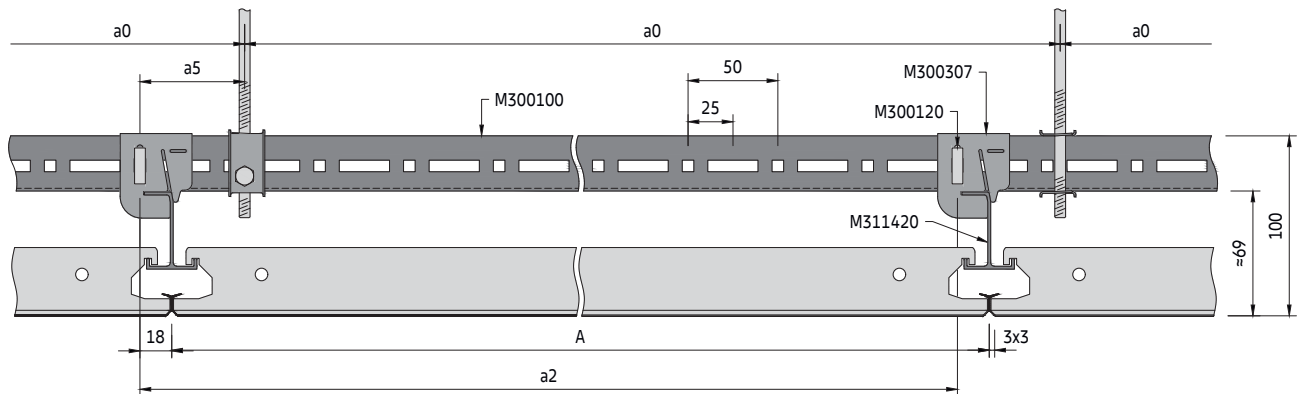

Secondary grid components

Standard components

- M311420 H-Profile 28
- M300343 Splice connector for H-Profile 28
- M300307 Hanger for H-Profile 28
- M300120 Plug-in clip for U-Profile

Optional components

- M300235 Security clip (METAL R-H 220)
- M311034 Extraction tool (METAL R-H 220)
- M311191 Self-drilling screw 3.5 x 9.5 mm
- M900000 Black gasket 8x3 mm (spare roll) (METAL R-H 220)

See U-Profile primary grid for primary grid components

H-Profile 28 secondary grid

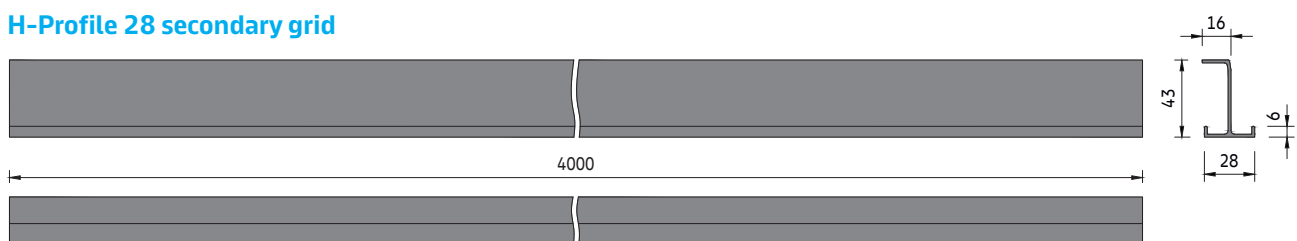

METAL R-H 220 / METAL Q-H 120 F

D02.106

Section G (METAL R-H 220)

Example with suspension option E1

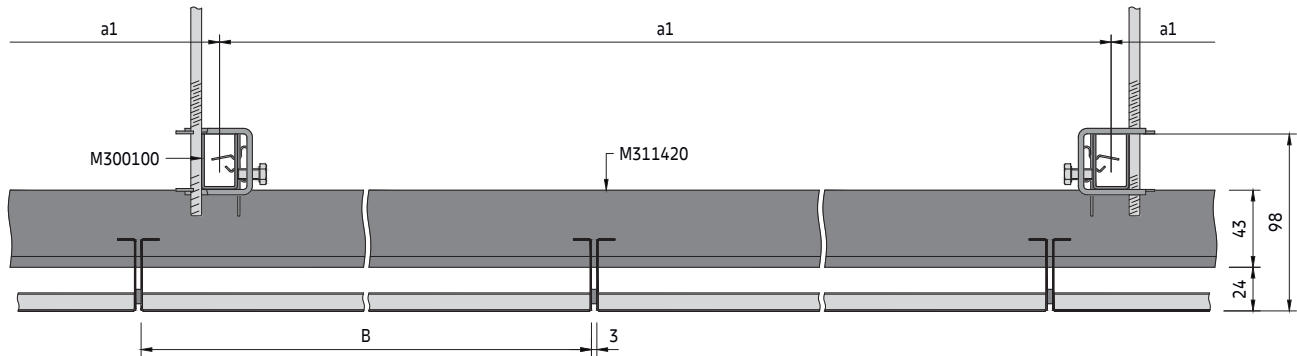

Panels supplied as standard with a 3 mm gasket on one long side, to improve visual appearance. Optionally panels can be installed without a gasket.

Section G (METAL Q-H 120 F)

Example with suspension option E1

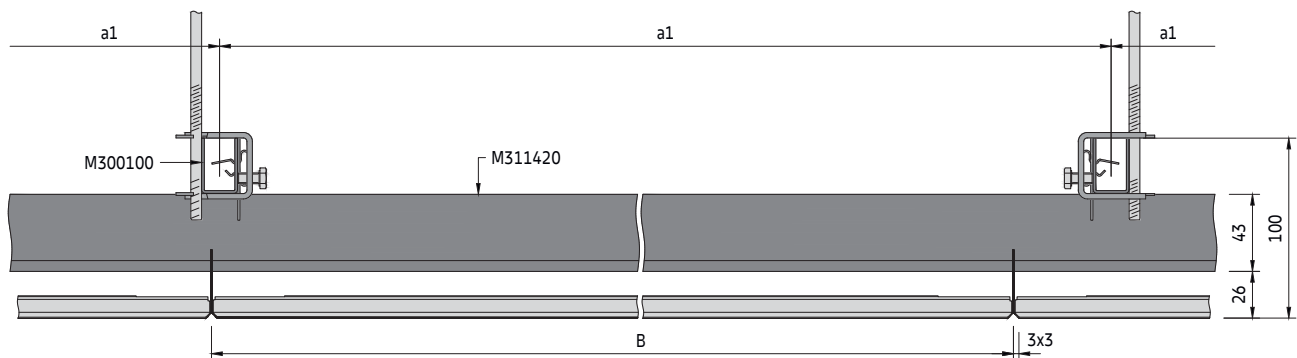

METAL R-H 220 / METAL Q-H 120 F

D02.106

Spacing

a2 [mm]	System without additional load		System with additional load +4 kg/m ²	
	a0 [mm]	a1 [mm]	a0 [mm]	a1 [mm]
600	1200	1800	1200	1550
650	1300	1700	1300	1500
700	1400	1650	1400	1300
750	1500	1600	750	1150
800	1600	1550	800	1350
850	1700	1350	850	1300
900	900	1500	900	1250
950	950	1450	950	1250
1000	1000	1400	1000	1200
1050	1050	1350	1050	1150
1100	1100	1350	1100	1150
1150	1150	1300	1150	1150
1200	1200	1300	1200	1100
1250	1250	1250	1250	1100
1300	1300	1250	1300	1050
1350	1350	1200	1350	1050
1400	1400	1200	1400	1000
1450	1450	1150	1450	1000
1500	1500	1150	1500	1000
1550	1550	1150	1550	950
1600	1600	1100	1600	950
1650	1650	1100	1650	950
1700	1700	1100	1700	900
1750	1750	1100	1750	800
1800	1800	1050	1800	750
1850	1850	1050	1850	700
1900	1900	950	1900	600
1950	975	1000	975	850
2000	1000	1000	1000	850
2050	1025	1000	1025	850
2100	1050	950	1050	850
2150	1075	950	1075	850
2200	1100	950	1100	800
2250	1125	950	1125	800
2300	1150	950	1150	800
2350	1175	900	1175	800
2400	1200	900	1200	800
2450	1225	900	1225	750
2500	1250	900	1250	750
2600	1300	850	1300	750
2700	1350	850	1350	750
2800	1400	800	1400	700
2900	1450	800	1450	700
3000	1500	800	1500	700
3100	1550	800	1550	650
3200	1600	750	1600	650
3300	1650	750	1650	650

Parameters

- a0 Distance between U-Profile suspension points = max. 1900 mm
- a1 Max. distance between U-Profiles
- a2 Distance between H-Profiles 28 = panel length + gasket
- a3 Distance from wall = max. 200 mm
- a4 Distance from wall = max. panel length
- a5 Distance from U-Profile suspension point to hanger = max. 100 mm
- M Module size = panel length / panel width + gasket

METAL R-H 220

- A Panel length = min. 600 / max. 3300 mm
- B Panel width = min. 247 / max. 1350 mm

METAL Q-H 120 F

- M 625 x 625 mm

Typical grid layout

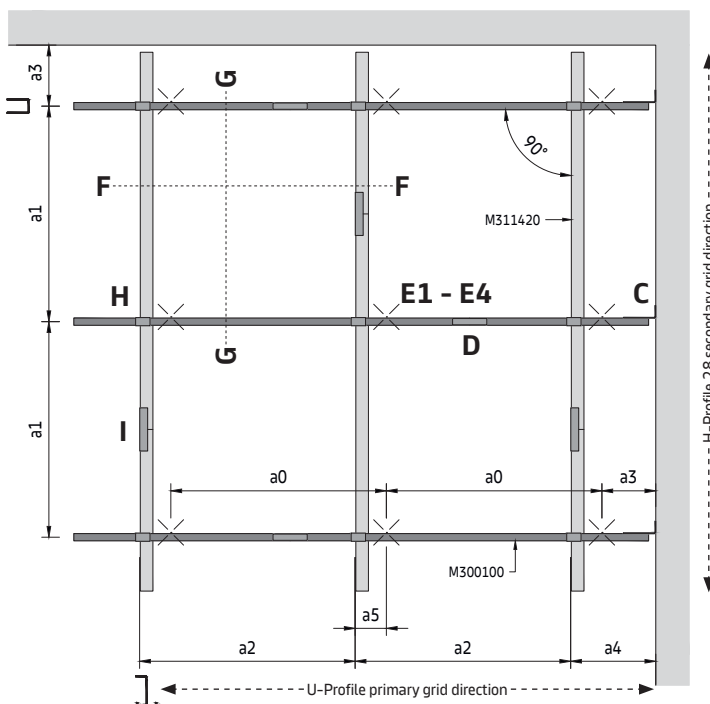

To determine suspension layout

The module length (M) of the requested ceiling is equal to the distance between the H-Profile 28 centres (a2).

On the appropriate spacing table, read down the column headed (a2) to the required module length then read across to determine the suspension point spacing (a0) and U-Profile spacing (a1).

The shown values are maximum allowed distances and can be reduced but not exceeded.

METAL R-H 220 / METAL Q-H 120 F
D02.106

Detail H

Hanger installation

- 1

Place the hanger on the U-profile.

- 2

Optional fixing

Vertical Horizontal

M300120

Fix hanger with plug-in clips at the specified module spacing (inserted vertically or horizontally). If the panel size does not fit with the modulation of the U-Profile (25 mm increments), the plug-in clip needs to be inserted into a long hole. The hanger position can alternatively be fixed by using a pop-riquet or self-drilling screw.

- 3

M311420

Insert the H-profile 28 into the hanger, press down the two hanger wings to lock the position of the H-Profile 28.

- 4

max. 30

The H-Profile 28 is now locked in position.

Detail I

Splice connection

- 1

M311420

Once the H-Profiles 28 are installed under the U-Profiles, the ends should be brought together without a gap.

- 2

M300343

The connectors for the H-Profile 28 must be inserted from above.

- 3

2x

max. 3.5 Nm

Use the bolts to secure the connector. Stagger the joints.

Detail J

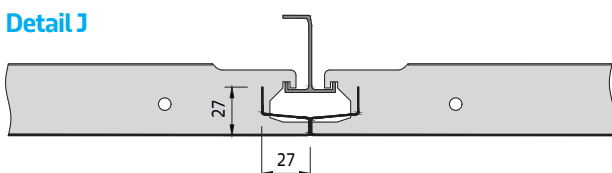

Wide panel option >625 mm

METAL R-H 220 / METAL Q-H 120 F

D02.106

Detail K

Panel insertion

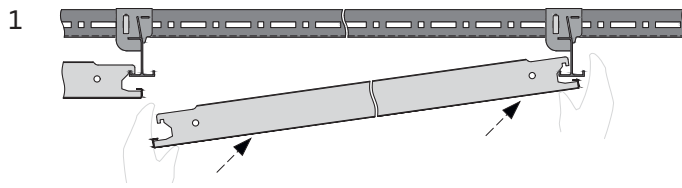

First hang the panels with the two hooks at one end.

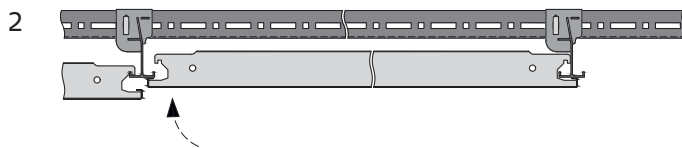

Lift the opposite end of the panel to a horizontal position.

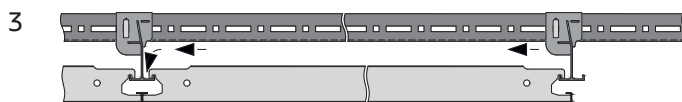

Now hang the opposite end of the panel with the hooks.

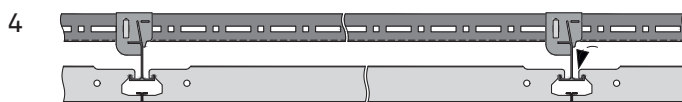

Make sure that all four hooks on the panel are hooked on to the H-Profiles 28.

For METAL Q-H 120 F the sequence is the same.

Panel extraction

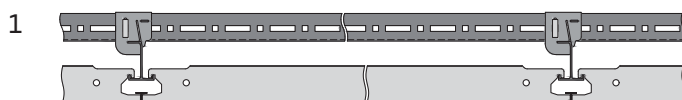

With a closed ceiling, any panel can be removed as long as there are no obstacles such as service integrations, etc.

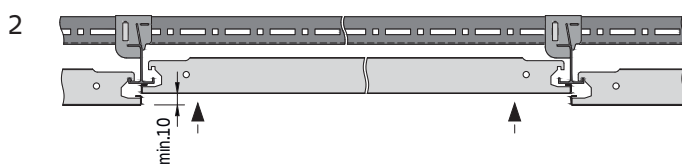

Lift the panel min. 12 mm.

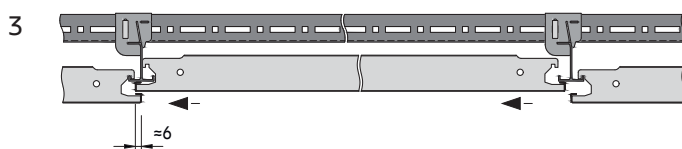

Slide it horizontally lengthwise (to the left or right) so that the end fits between the next panel and the H-Profile 28.

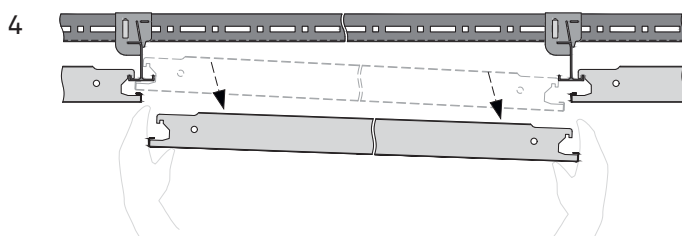

Remove it downwards and store the panel in a safe place so that it cannot be damaged.

For METAL Q-H 120 F the sequence is the same.

METAL R-H 220 / METAL Q-H 120 F

D02.106

Detail L

Optional security clip

The security clip serves to secure the panels and prevents them from being removed without the use of the appropriate extraction tool.

- 1 The clip is placed at the crossing point between the panels. One security clip per panel is needed and can only be used for panels with a width up to 625 mm.

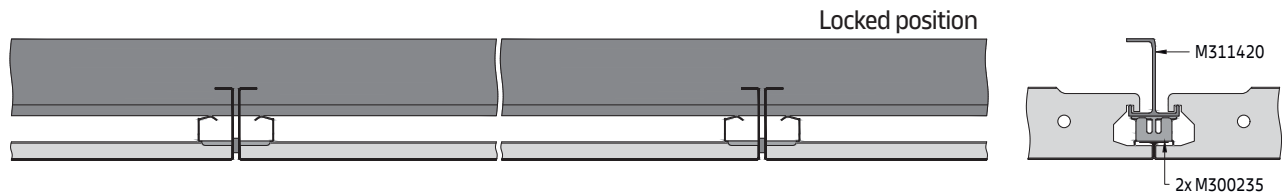

- 2 Unlock the panel, by sliding the security clips about 25 - 50 mm above the panels to the left and right. The appropriate extraction tool must be used. Be careful to not damage the gasket.

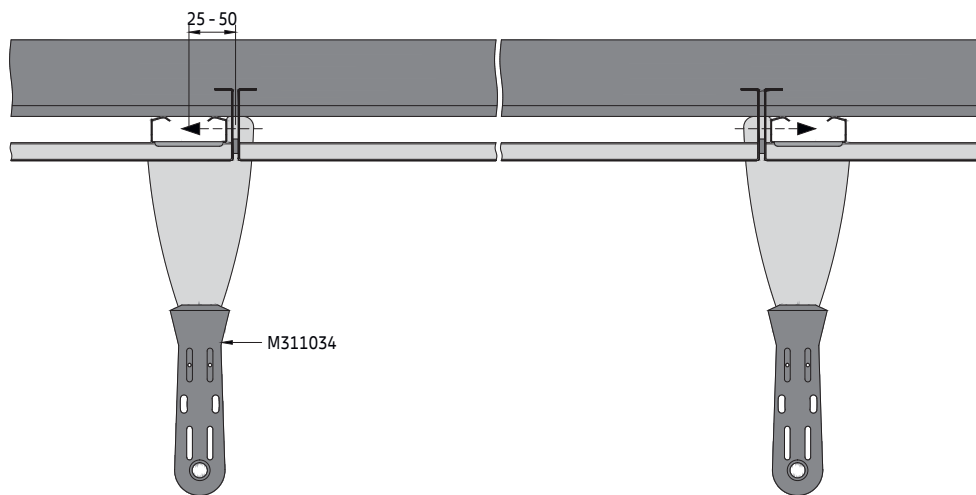

- 3 The panel can be extracted downwards, as explained in the panel extraction sequence.

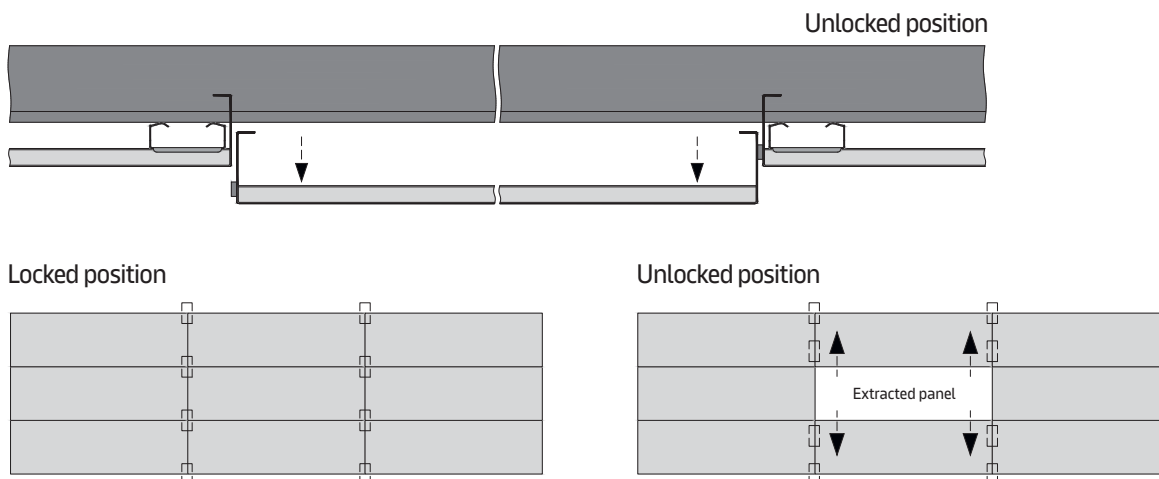

METAL R-H 220 / METAL Q-H 120 F

D02.106

Material required per m² (no waste included)**System without additional load [pcs/m²]**

Components		a2 [mm]	1200	1600	1800	2000	2400	2800	3100	3300
M300100	U-Profile		0.21	0.24	0.25	0.27	0.30	0.33	0.33	0.36
M300119	Splice connector for U-Profile		0.21	0.25	0.26	0.27	0.30	0.34	0.34	0.36
M300120	Plug-in clip for U-Profile		1.07	1.07	1.05	1.04	1.07	1.13	1.09	1.13
M300140	Wall anchor		0.08	0.10	0.10	0.11	0.12	0.13	0.13	0.14
M300307	Hanger for H-Profile 28		0.65	0.57	0.53	0.50	0.47	0.45	0.41	0.41
M300343	Splice connector for H-Profile 28		0.21	0.16	0.14	0.13	0.11	0.09	0.09	0.08
M311103	Hexagonal nut M6		0.10	0.10	0.10	0.10	0.10	0.20	0.20	0.20
M311105	Washer		0.10	0.10	0.10	0.10	0.10	0.20	0.20	0.20
M311303	Hexagonal bolt M6 x 16 mm		0.10	0.10	0.10	0.10	0.10	0.20	0.20	0.20
M311420	H-Profile 28		2.09	1.57	1.39	1.25	1.05	0.90	0.81	0.76
Various	Suspension points (E1 - E4)		0.65	0.57	0.53	1.00	0.93	0.90	0.81	0.81

The shown quantities are theoretical and based on an ideal layout, without considering the actual room layout. The ideal layout is based on a calculation of 10 x 10 m (100 m²). This calculation does not allow any damage, spare nor wastage. The final quantities and type of suspension have to be checked before ordering. Soffit and wall fixings by others. Not including perimeter trims, optional security clips and extraction tools.

METAL R-H 220 / METAL Q-H 120 F

Swiss market only

Direct suspended H-Profile 28

Concealed grid solution for indoor applications

General information

- Concealed hook-on grid system for small rooms with low cavity
- For perpendicular installation
- H-Profile 28 made of aluminium
- Typical ceiling weight 7.0 - 8.5 kg/m² (METAL R-H 220), 5.0 kg/m² (METAL Q-H 120 F) (indicative value for unperforated panels, without additional load)
- Panels are easily installed and fully demountable
- Security option available (METAL R-H 220)

Isometric view

Perimeter solutions on separate datasheet.

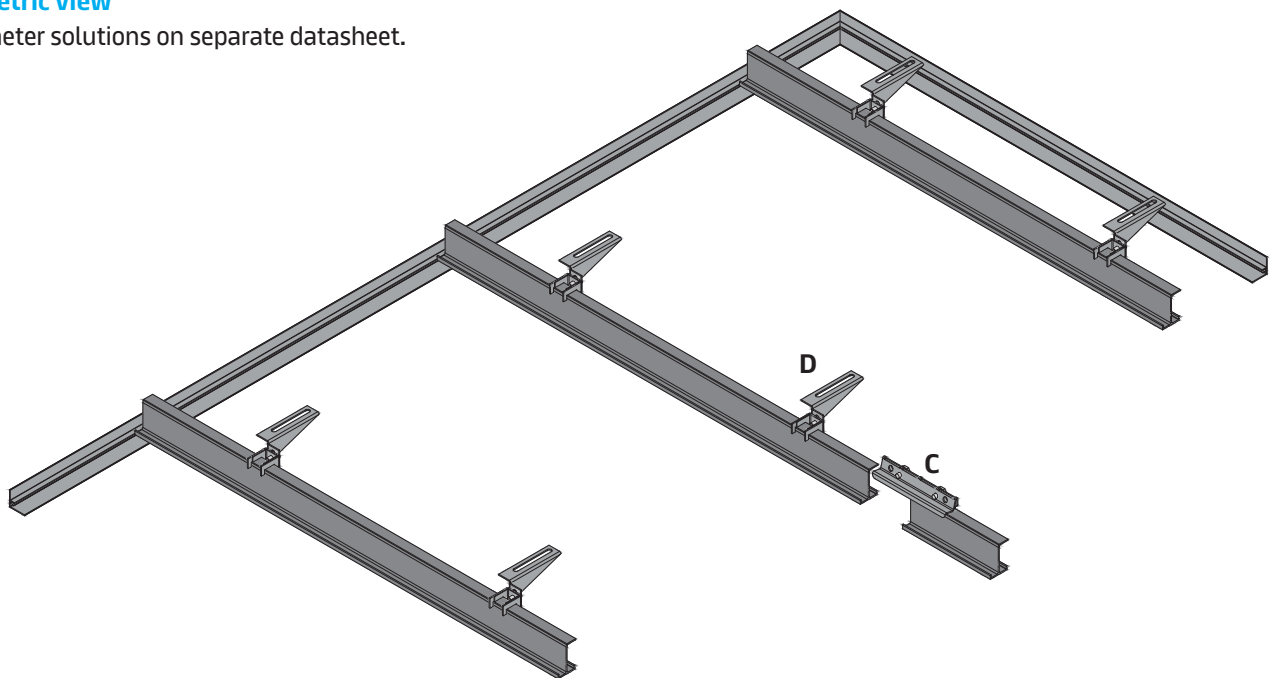

The use of a primary grid system is recommended, as this simplifies levelling and the alignment of the ceiling.

Standard & Vario Design layout options

Standard

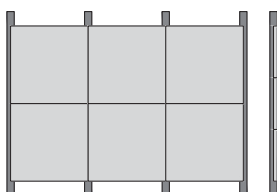

Vario Design

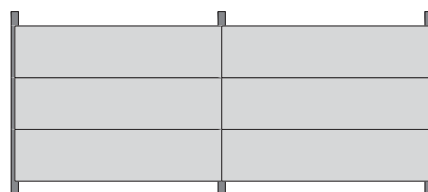

METAL R-H 220 / METAL Q-H 120 F

D02.106.1

Section A (METAL R-H 220)

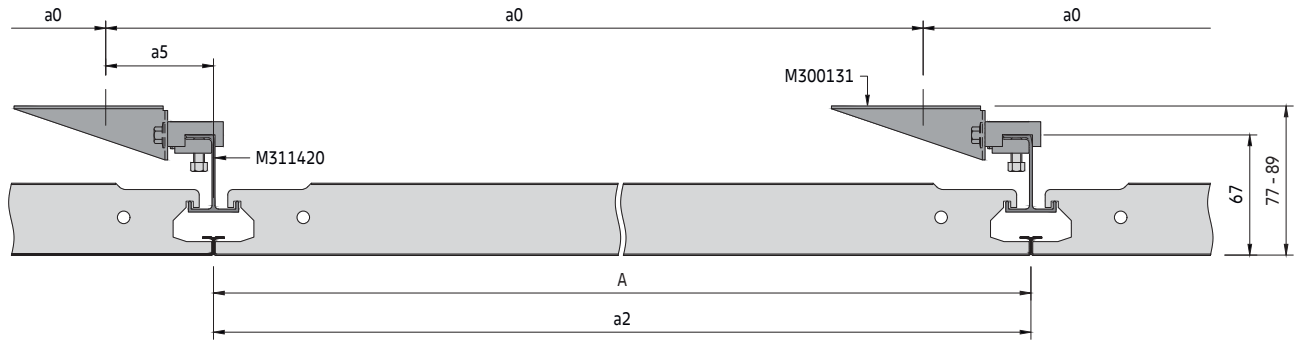

Section A (METAL Q-H 120 F)

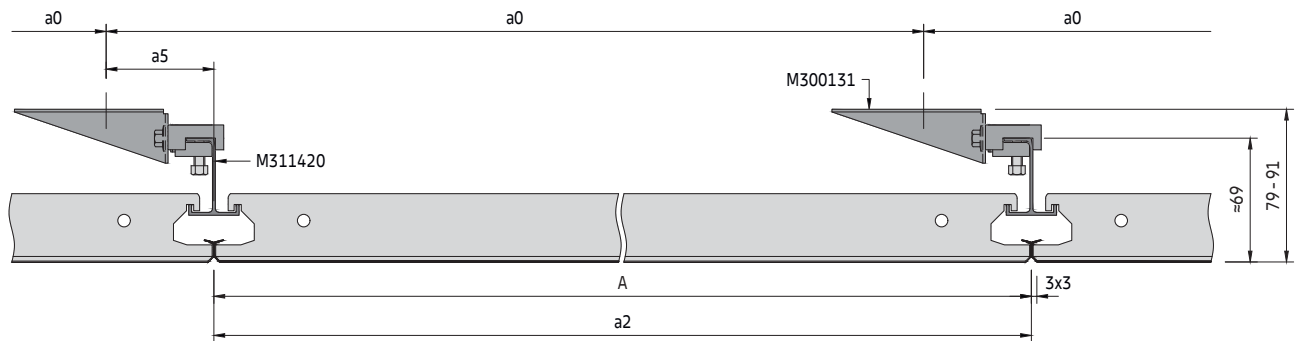

Grid components

Standard components

- M311420 H-Profile 28
- M300343 Splice connector for H-Profile 28
- M300131 Direct hanger for H-Profile 28

Optional components

- M300235 Security clip (METAL R-H 220)
- M311034 Extraction tool (METAL R-H 220)
- M900000 Black gasket 8x3 mm (spare roll) (METAL R-H 220)

H-Profile 28

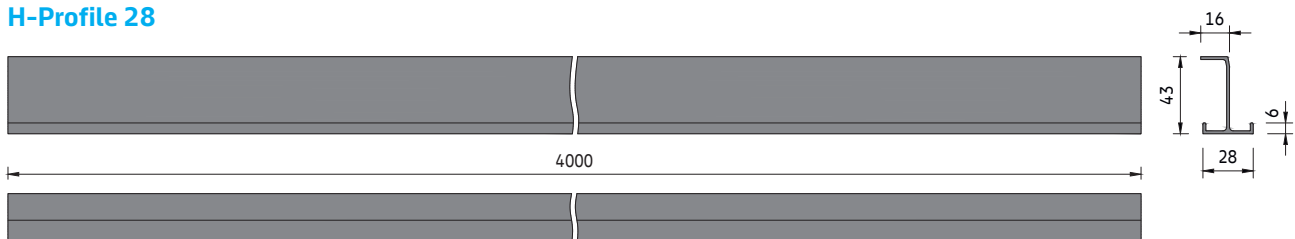

METAL R-H 220 / METAL Q-H 120 F

D02.106.1

Section B (METAL R-H 220)

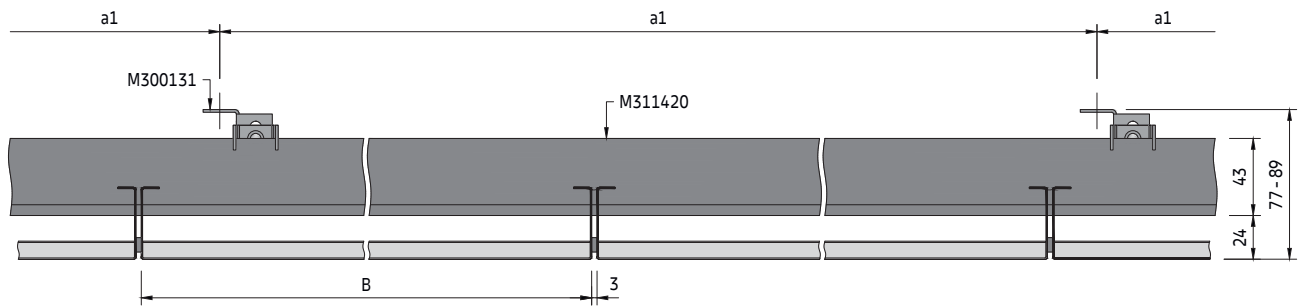

Panels supplied as standard with a 3 mm gasket on one long side to improve the visual appearance. Optionally panels can be installed without a gasket.

Section B (METAL Q-H 120 F)

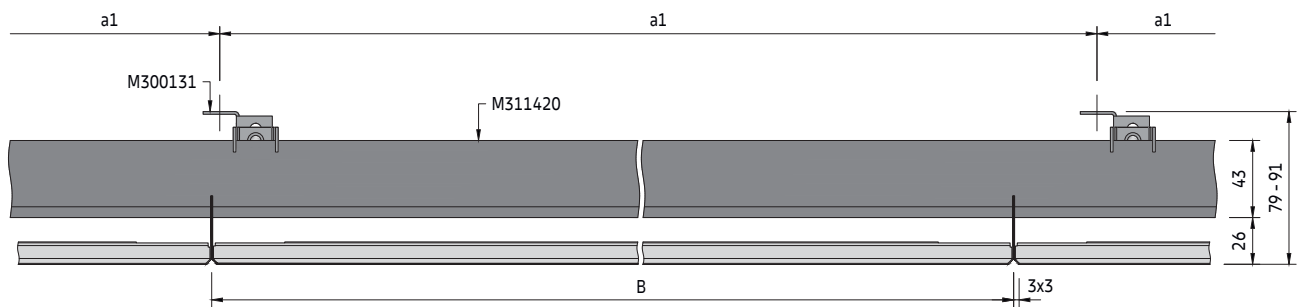

METAL R-H 220 / METAL Q-H 120 F
D02.106.1

Spacing

a2 [mm]	System without additional load		System with additional load +4 kg/m²	
	a0 [mm]	a1 [mm]	a0 [mm]	a1 [mm]
600	600	1500	600	1500
650	650	1500	650	1500
700	700	1500	700	1500
750	750	1500	750	1500
800	800	1500	800	1500
850	850	1500	850	1500
900	900	1500	900	1500
950	950	1500	950	1500
1000	1000	1500	1000	1500
1050	1050	1500	1050	1500
1100	1100	1500	1100	1500
1150	1150	1500	1150	1200
1200	1200	1500	1200	1200
1250	1250	1500	1250	1200
1300	1300	1500	1300	1200
1350	1350	1500	1350	1200
1400	1400	1500	1400	1200
1450	1450	1200	1450	1200
1500	1500	1200	1500	1000
1550	1550	1200	1550	1000
1600	1600	1200	1600	1000
1650	1650	1200	1650	800
1700	1700	1200	1700	800
1750	1750	1200	1750	800
1800	1800	1000	1800	600
1850	1850	1000	1850	600
1900	1900	800	1900	600
1950	1950	800	1950	600
2000	2000	800	2000	600
2050	2050	800	2050	600
2100	2100	800	2100	600
2150	2150	800	2150	600
2200	2200	800	2200	600
2250	2250	800	2250	400
2300	2300	800	2300	400
2350	2350	600	2350	400
2400	2400	600	2400	400
2450	2450	600	2450	400
2500	2500	600	2500	400
2600	2600	600	2600	400
2700	2700	600	2700	400
2800	2800	600	2800	400
2900	2900	600	2900	400
3000	3000	600	3000	400
3100	3100	600	3100	400
3200	3200	600	3200	400
3300	3300	600	3300	400

Parameters

- a0 Distance between H-Profile 28 suspension points = max. 1900 mm
- a1 Max. distance between direct hangers
- a2 Distance between H-Profiles 28 = panel length + gasket
- a3 Distance from wall = max. 200 mm
- a4 Distance from wall = max. panel length
- a5 Distance tile / panel joint and top fixing = max. 70 mm
- M Module size = panel length / panel width + gasket

METAL R-H 220

- A Panel length = min. 600 / max. 3300 mm
- B Panel width = min. 247 / max. 1350 mm

METAL Q-H 120 F

- M 625 x 625 mm

Typical grid layout

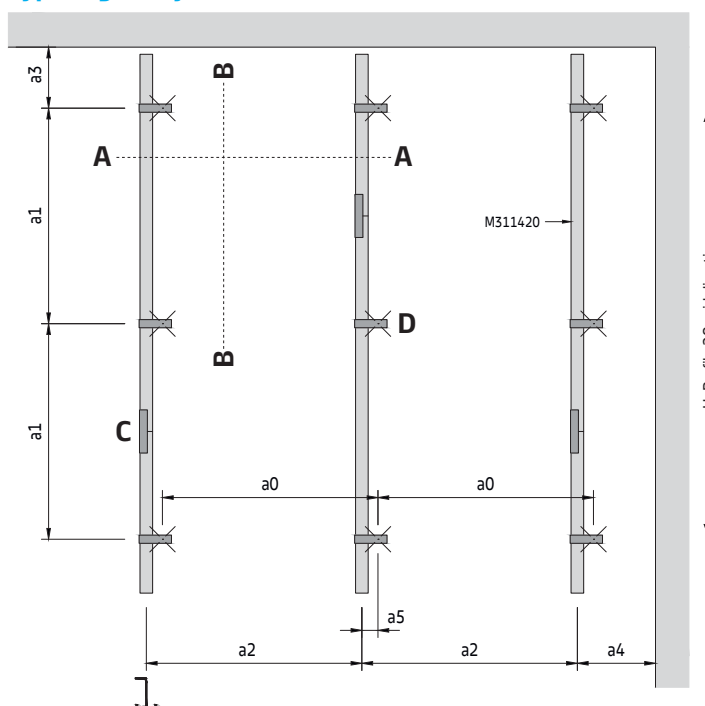

To determine suspension layout

The module length (M) of the requested ceiling is equal to the distance between the DP12 A-Bar centres (a2).

On the appropriate spacing table, read down the column headed (a2) to the required module length then read across to determine the suspension point spacing (a0) and direct hanger spacing (a1).

The shown values are maximum allowed distances and can be reduced but not exceeded.

METAL R-H 220 / METAL Q-H 120 F
D02.106.1

Detail C
Splice connection

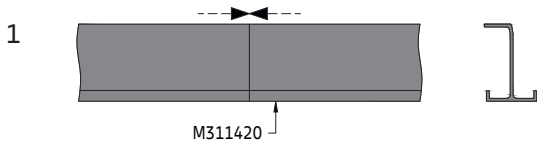

Once the H-Profiles 28 are installed, the ends should be brought together without a gap.



The connectors for the H-Profile 28 must be inserted from above.

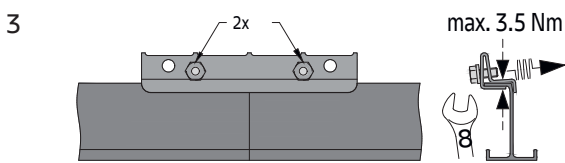

Use the bolts to secure the connector. Stagger the joints.

Detail D
Direct hanger installation

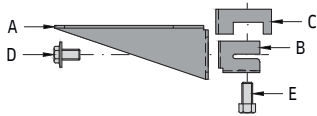

The direct hanger consists of five pre-assembled components (A, B, C, D, E).

METAL Q-H 120 F

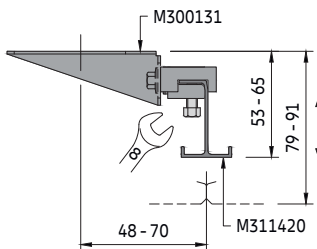

METAL R-H 220

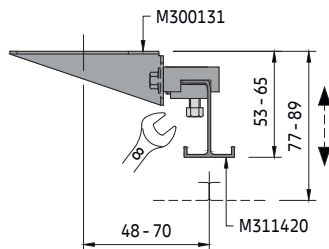

Part A is attached to the soffit first. The distance from the H-Profile 28 to the attachment point must not exceed 70 mm.

Part B is not tightened, so the H-Profile 28 can be inserted horizontally. Tightening the bolts (part D, E) creates a stable connection. Before that, the height should be set up and part C inserted from above. Part C is positioned between part A and B and prevents the H-Profile 28 from falling out of the hanger.

Optional installation

METAL Q-H 120 F

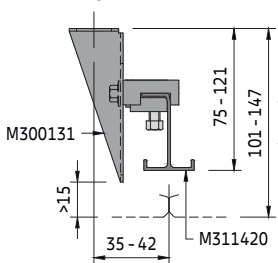

METAL R-H 220

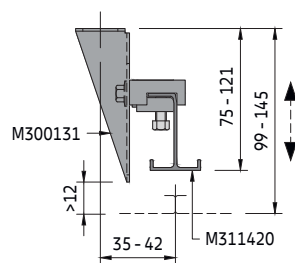

The distance between the H-Profiles 28 should be measured exactly, otherwise the panels are difficult to install and elements could fall out.

The direct hanger can optionally also be installed vertically. To do this, the components must first be disassembled. The shorter side of part A is then attached to the soffit.

Detail E
Wide panel option > 625 mm

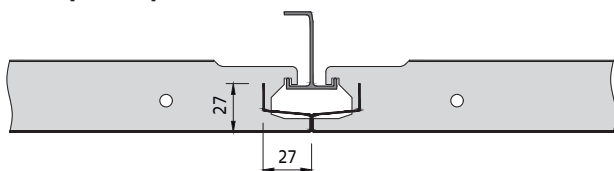

METAL R-H 220 / METAL Q-H 120 F

D02.106.1

Detail F

Panel insertion

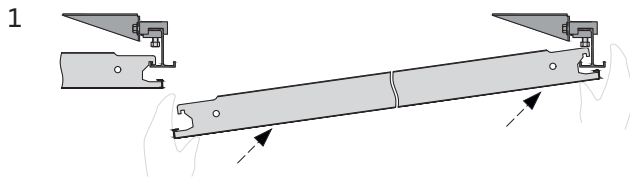

First hang the panels with the two hooks at one end.

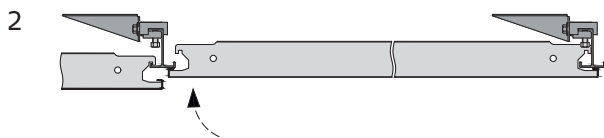

Lift the opposite end of the panel to a horizontal position.



Now hang the opposite end of the panel with the hooks.



Make sure that all four hooks on the panel are hooked onto the H-Profiles 28.

For METAL Q-H 120 F the sequence is the same.

Panel extraction



With a closed ceiling, any panel can be removed as long as there are no obstacles such as service integrations, etc.

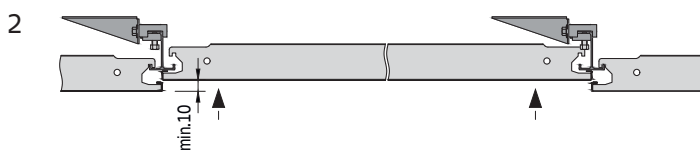

Lift the panel min. 12 mm.

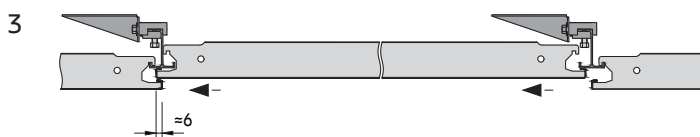

Slide it horizontally lengthwise (to the left or right) so that the end fits between the next panel and the H-Profile 28.

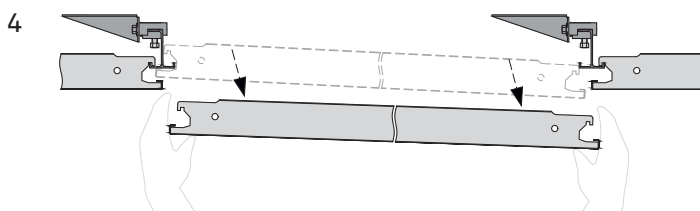

Remove it downwards and store the panel in a safe place so that it cannot be damaged.

For METAL Q-H 120 F the sequence is the same.

METAL R-H 220 / METAL Q-H 120 F

D02.106.1

Detail G

Optional security clip

The security clip serves to secure the panels and prevents them from being removed without the use of the appropriate extraction tool.

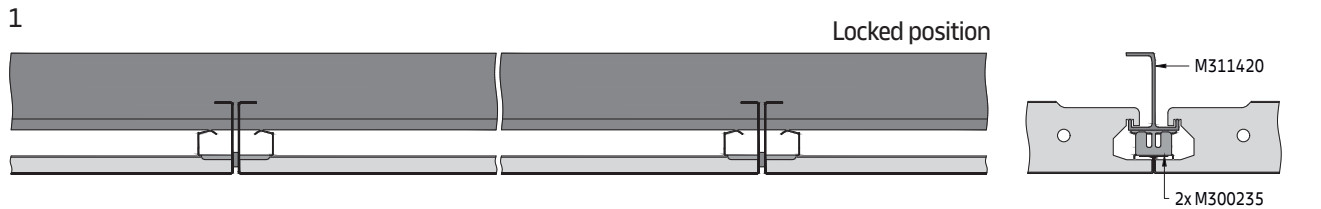

The clip is placed at the crossing point between the panels. One security clip per panel is needed and can only be used for panels with a width up to 625 mm.

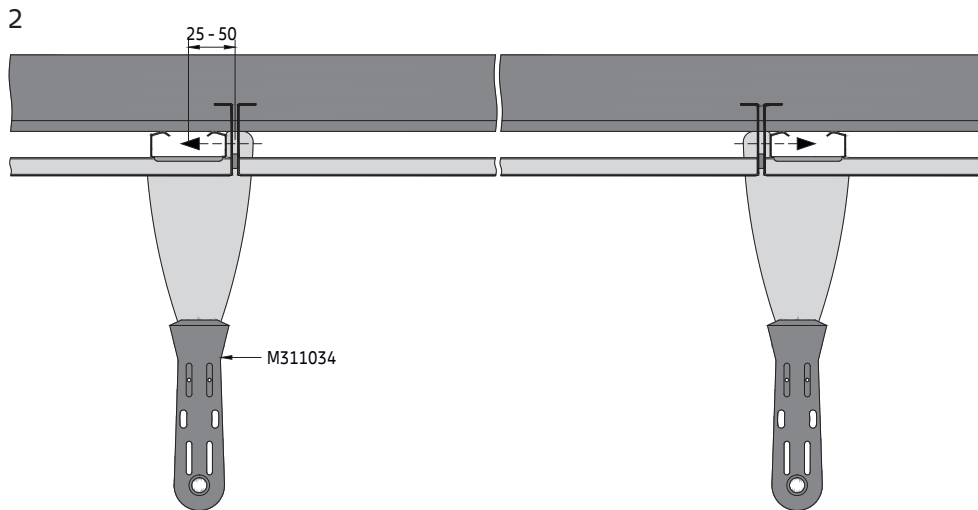

Unlock the panel, by sliding the security clips about 25 - 50 mm above the panels to the left and right. The appropriate extraction tool must be used. Be careful to not damage the gasket.

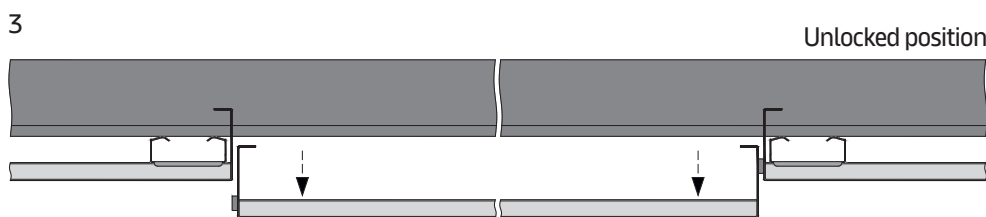

The panel can be extracted downwards, as explained in the panel extraction sequence.

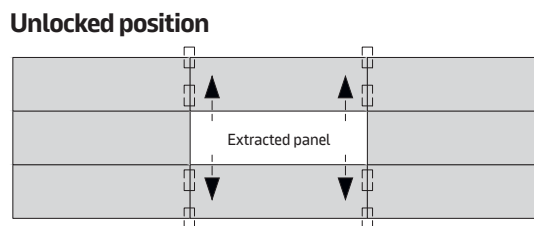
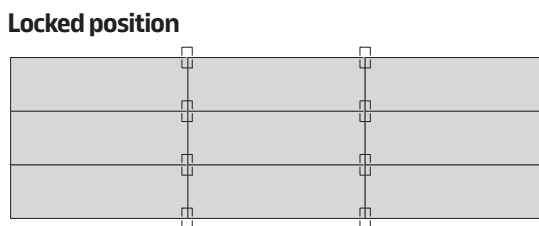

METAL R-H 220 / METAL Q-H 120 F

D02.106.1

Material required per m² (no waste included)**System without additional load [pcs/m²]**

Components		a2 [mm]	1200	1600	1800	2000	2400	2800	3100	3300
M300131	Direct hanger for H-Profile 28		0.56	0.52	0.56	0.63	0.69	0.6	0.54	0.51
M300343	Splice connector for H-Profile 28		0.21	0.16	0.14	0.13	0.11	0.09	0.09	0.08
M311420	H-Profile 28		2.09	1.57	1.39	1.25	1.05	0.9	0.81	0.76

The shown quantities are theoretical and based on an ideal layout, without considering the actual room layout. The ideal layout is based on a calculation of 10 x 10 m (100 m²). This calculation does not allow any damage, spare nor wastage. The final quantities and type of suspension have to be checked before ordering. Soffit and wall fixings by others. Not including perimeter trims, optional security clips and extraction tools.



METAL Grille Cellio
Oscar Romero College, Dendermonde, Belgium
© Dion de Bakker



***Grille –
Open Cell***

METAL Grille Cellio

15 mm T-Grid, butt-cut

Exposed grid solution for open cell layout indoor applications

General information

- Exposed lay-in grid system for small, medium and large rooms
- Typical ceiling weight 3.0 - 6.0 kg/m² (indicative value, without additional load)
- Tiles made out of pre-coated galvanised steel, various standard colours available
- Tiles are easily installed and fully demountable

Isometric view

Select the suspension option.
Perimeter solutions on separate datasheet.

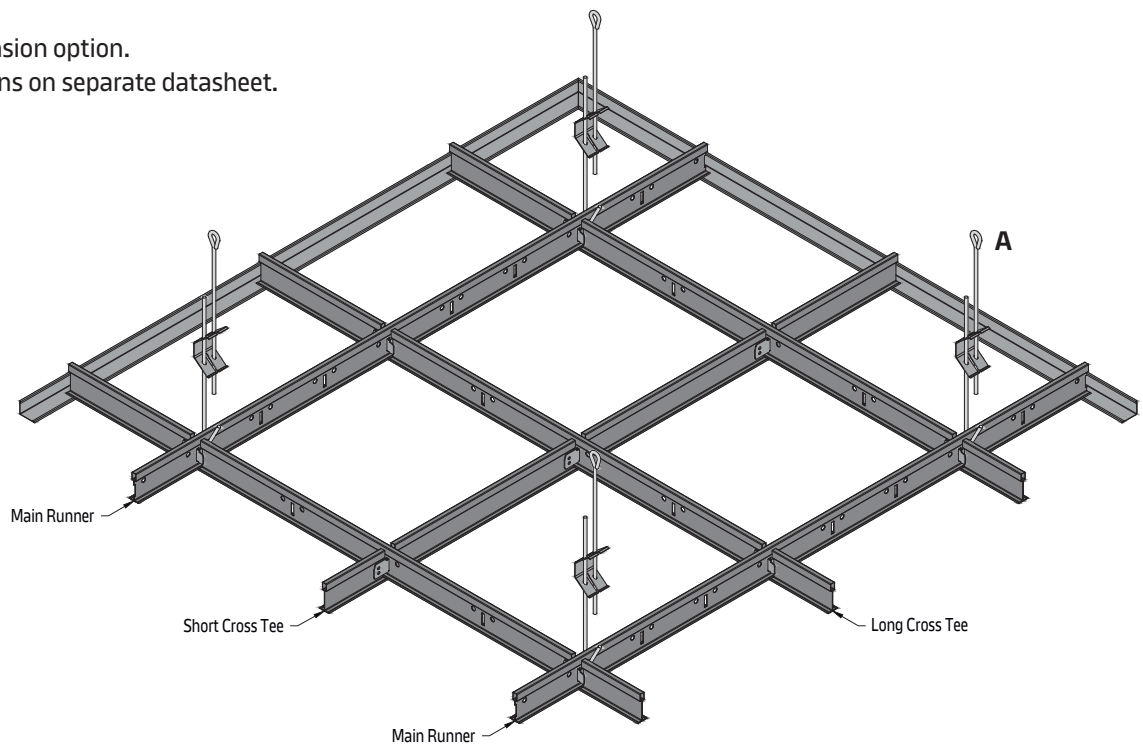

Standard layout

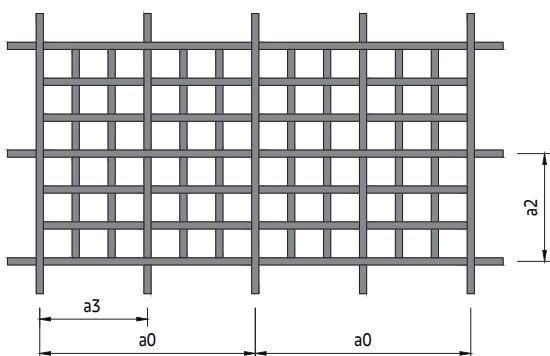

Section B

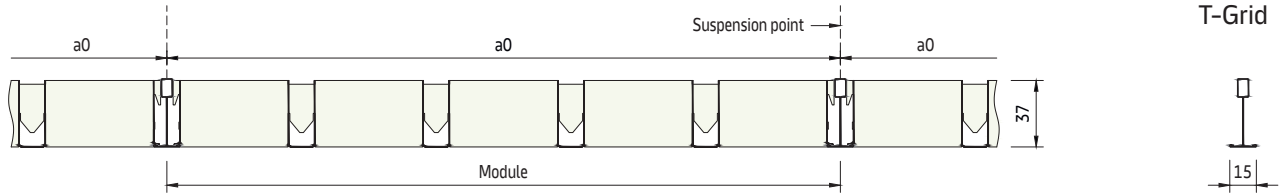

Modules

C64 (8x8 cells)

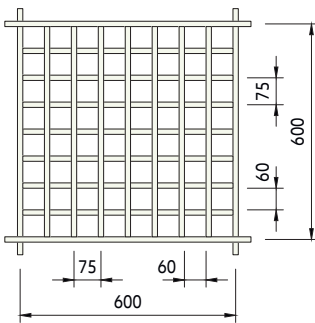

C49 (7x7 cells)

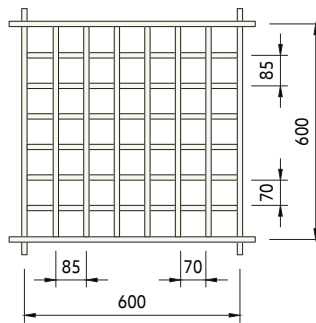

C36 (6x6 cells)

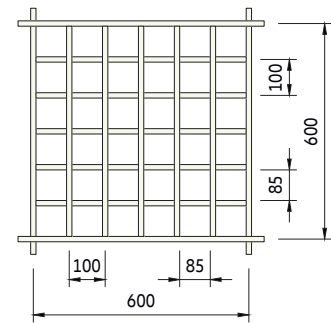

C25 (5x5 cells)

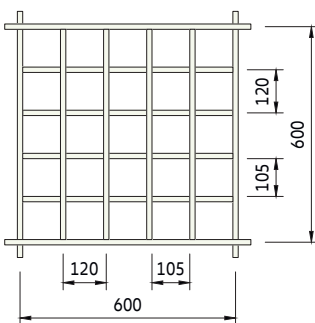

C16 (4x4 cells)

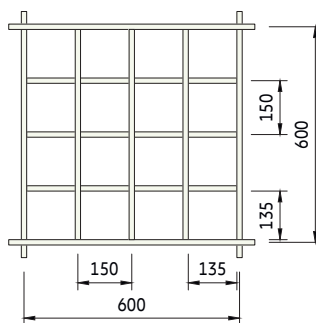

C9 (3x3 cells)

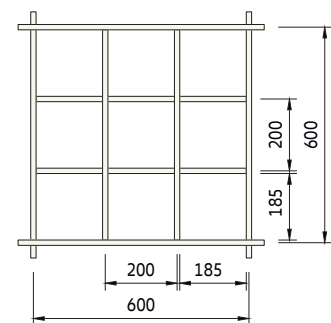

G8

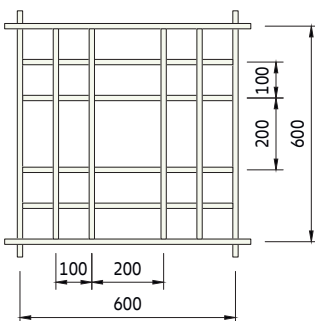

G10

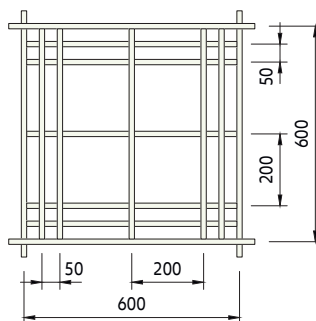

G13

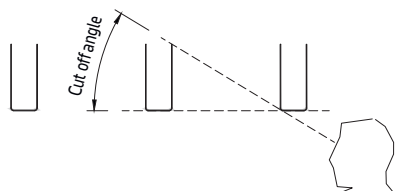
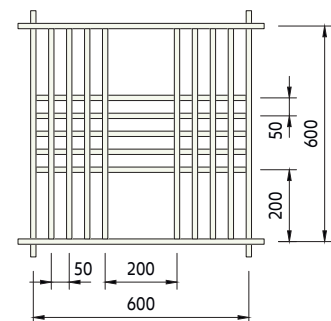

Values

Module		C64	C49	C36	C25	C16	C9
Cut off angle	[°]	31	27	23	19	15	11
Open area	[%]	64	68	72	76	81	85
Tile weight	[kg/m ²]	5.1	4.5	3.9	3.3	2.6	2.1

Typical grid layout

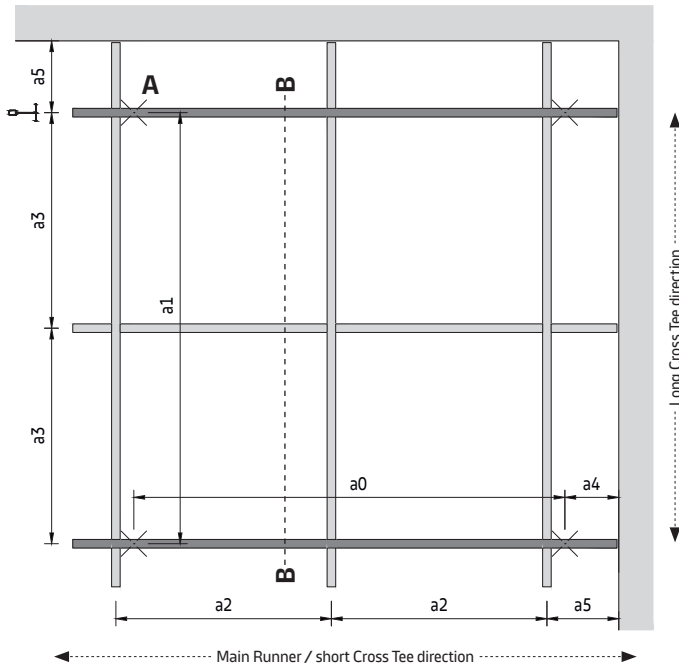

Parameters

- a0 Max. distance between Main Runner suspension points
- a1 Distance between Main Runner
- a2 Distance between Cross Tees (module width)
- a3 Distance between Cross Tees (module length)
- a4 Distance from wall = max. 250 mm
- a5 Distance from wall = max. module length / width, (min. 1/2 module length / width is recommended)

Spacing

System without additional load		
a2 [mm]	a0 [mm]	a1 [mm]
600	1500	1200

Start with the module width / distance between the long Cross Tees (a2) and take the values for (a0) and (a1) next to it. The shown values for (a0) are maximum allowed distances.

Material required per m² (no waste included)

System without additional load

Components	Module [mm]	600 x 600
Main Runner	[m/m ²]	84
Long Cross-Tee	[m/m ²]	167
Short Cross-Tee	[m/m ²]	84
Suspension points (A)	[pcs/m ²]	56

The shown quantities are theoretical and based on an ideal layout, without considering the actual room layout. The ideal layout is based on a calculation of 10 x 10 m (100 m²). This calculation does not allow any damage, spare nor wastage. The final quantities and type of suspension have to be checked before ordering. Soffit and wall fixings by others.

Not including perimeter trims.

Section C

Tile insertion

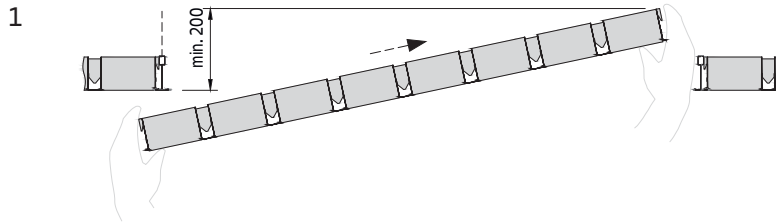

Since the height of the tiles is greater than that of other products, care must be taken where the hangers are placed. Always insert the opposite side first. Insert the tile diagonally. The minimum recommended installation height is 200 mm, depending on the selected suspension method. Care must be taken when choosing the right hangers.

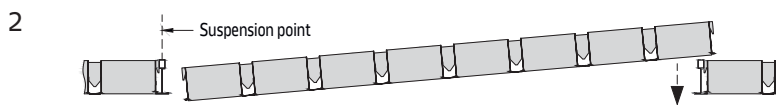

Place it on the T-Grid.



Tile extraction

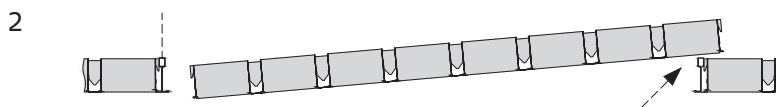
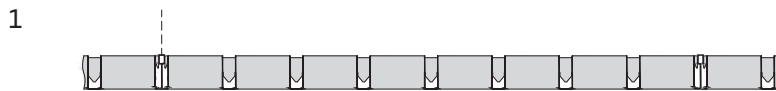

Lift the tile in one corner.

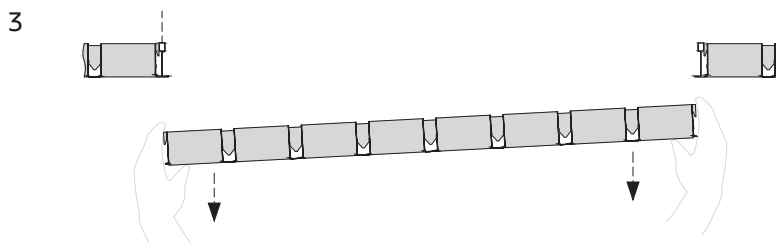

Remove it diagonally downwards.





***Free Span
Corridor Solutions***

METAL F-L 601

Perimeter trim range
Corridor solution for indoor applications

General information

- Lay-in system for corridors
- Range of perimeter trims in RAL 9010 (further colour options on request)
- Typical ceiling weight 6.7 – 7.4 kg/m² (indicative value for unperforated panels, without additional load)
- Panels are easily installed and fully demountable

Isometric view

Example with RA 4 F perimeter trim

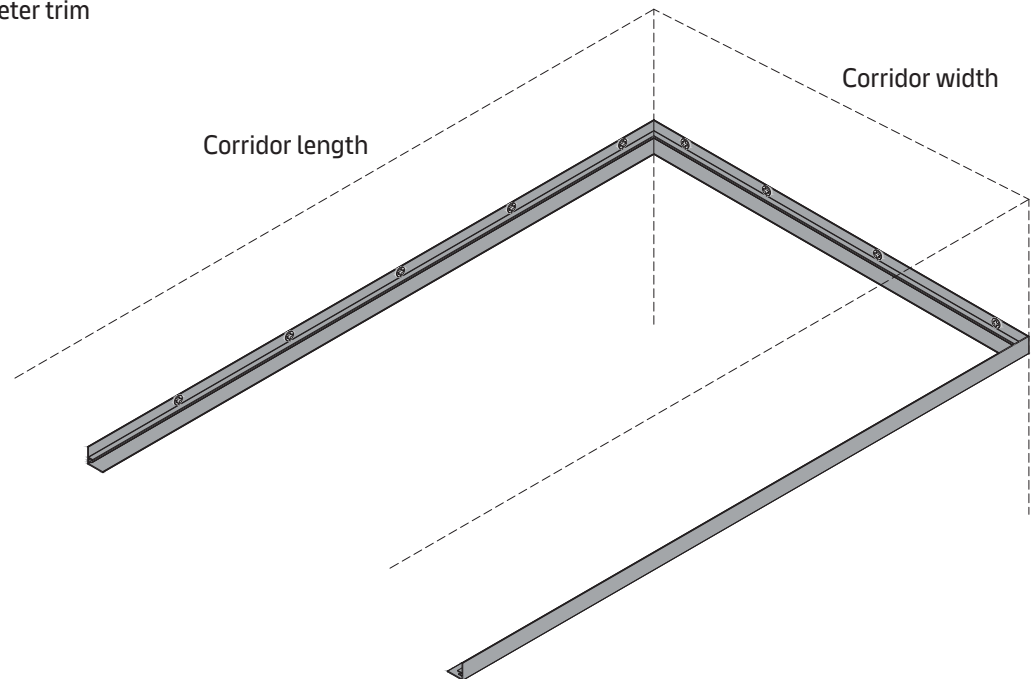

Vario Design layout options



Minimum installation height (H)

Panel length (A) [mm]

Perimeter trim	1000	1500	2000	2500	3000	3300
RA 1, RA 1 S, RA 2	145	185	200	230	250	260
RA 3, RA 3 S, RA 5 F	60	70	70	80	85	85
RA 4 F, RA 9 F	115	140	150	165	180	185
RA 6 F	50	60	60	70	80	80

Section A

Example with RA 1 perimetr trim

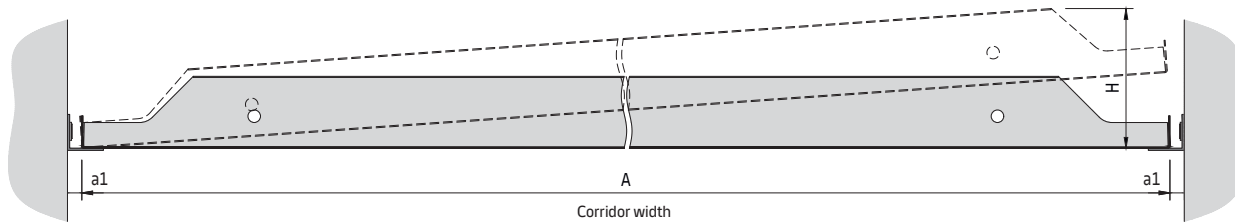

Section A

Example with RA 3 shadowline perimeter trim

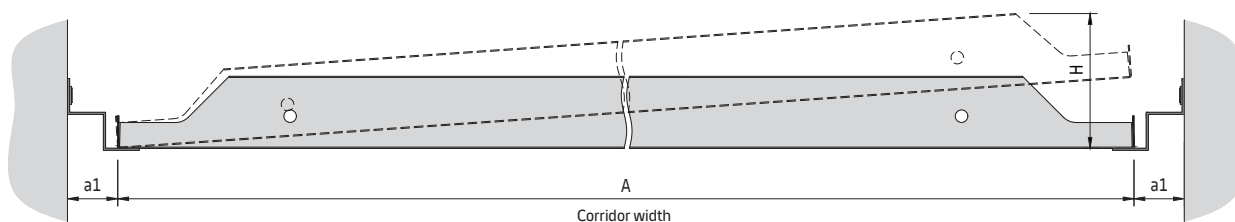

Section B

Example with RA 1 perimeter trim

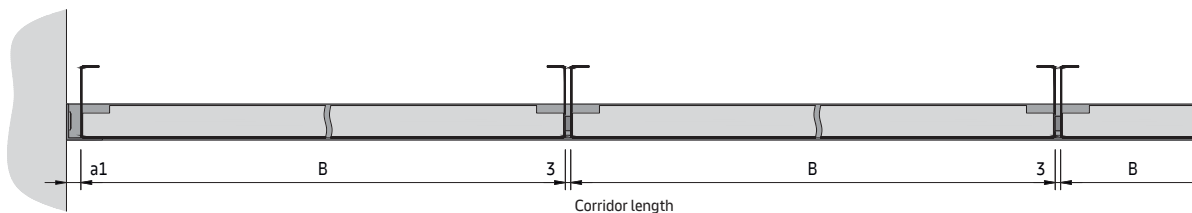

Panels supplied as standard with a 3 mm gasket on one long side to improve the visual appearance. Optionally panels can be installed without a gasket.

How to define the panel length (A)

Measure the corridor width. The distance measured at the widest point is used to define the panel length.

Panel length (A) = corridor width - 2x a1

In the narrower corridor areas, the panels may have to be cut to size.

See perimeter trim range for (a1) distances, perimeter trim options and detailed information.

Parameters

- a1 Distance from wall to panel (depending on the selected perimeter trim)
- X Distance between perimeter trim fixing points to wall
- A Panel length = min. 600 / max. 3300 mm
- B Panel width = min. 247 / max. 1350 mm

Grid components

Optional components

- M215440 L-Profile RAL 9010
- M311051 Primary angle 3000 x 27 x 22 mm
- M311099 Threaded rod M6 x 1000 mm
- M311103 Hexagonal nut M6
- M311191 Self-drilling screw 9.5 x 3.5 mm
- M311303 Hexagonal bolt M6 x 16 mm
- M311305 Washer
- M311330 Attachment bracket
- M900000 Black gasket 8x3 mm (spare roll)

METAL F-L 601
D02.400

Detail C

C1 - Transition with L-Profile

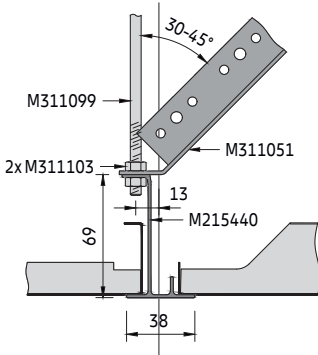

With T-junctions and corners you can use L-Profiles for the transition. The L-Profiles are suspended from the soffit with threaded rods at a distance of max. 1200 mm. The distance from the end to the first suspension point should be max. 200 mm. The L-Profile is aligned so that it is flush with one of the perimeter trims in the corner. In order to keep the L-Profile in position, an angle bracing is attached using a primary angle at an angle of 30 to 45°. This is connected at the top to an attachment bracket with an M6 nut and bolt. The attachment bracket is fixed to the soffit using appropriate fixings (by others). The end is cut at the bottom and bent to the required angle and attached to the L-profile with an M6 nut and bolt.

C2 - Transition with L-Profile, example with RA 1

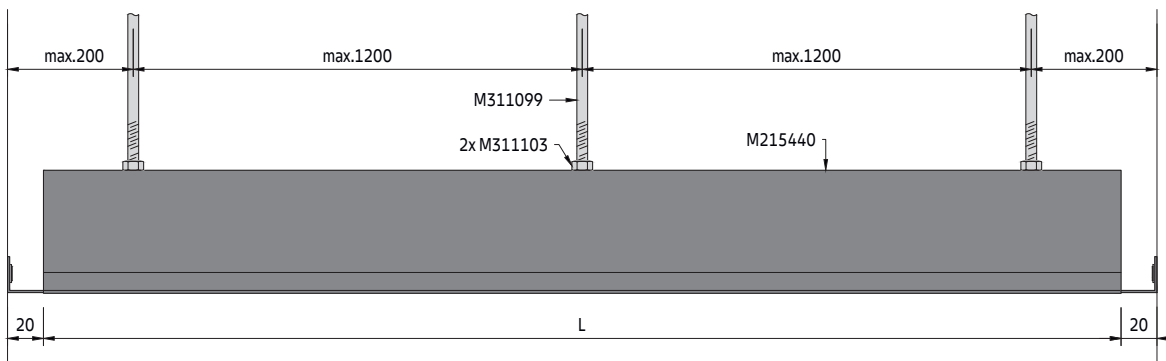

C3 - Transition example with RA 1

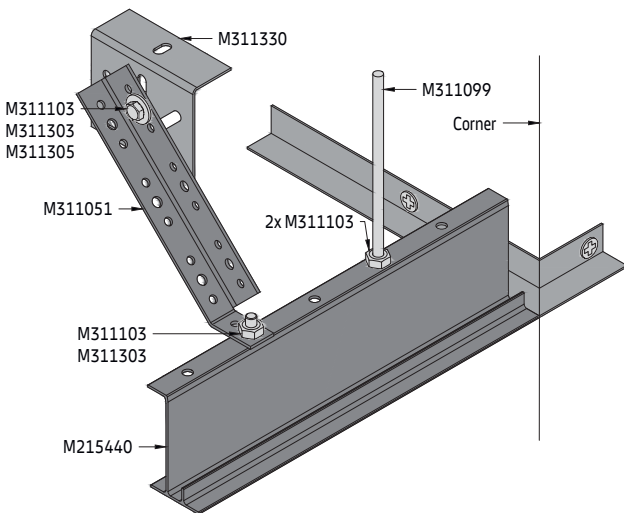

C4 - Transition example with RA 3

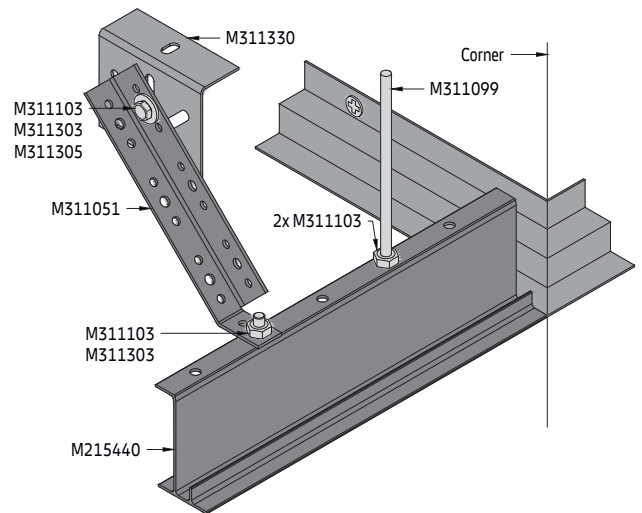

T-junction

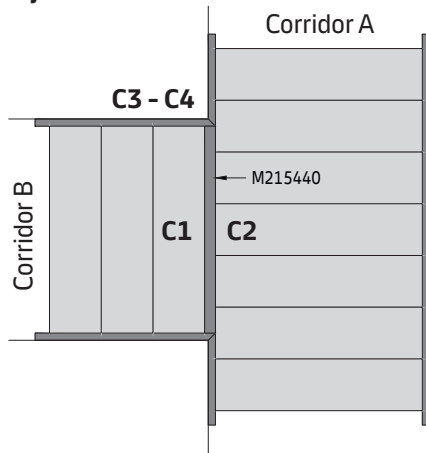

Corridor A runs through, corridor B connects to it and forms a T-junction.

Corner 1

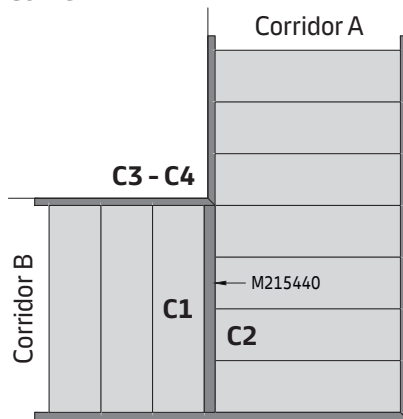

Corridor A runs to the end, corridor B connects to it and forms a transition.

Corner 1

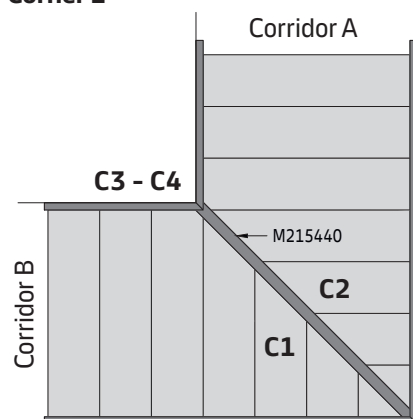

The L-Profile forms the transition and is attached diagonally, corridor A and B are equivalent. With this solution, the profile must be fitted exactly. Various details are possible. Panels get cut to size on site.

METAL F-L 601
D02.400

Detail D

As a transition, two perimeter trims can be fastened back to back. One of the perimeter trims forms an extension and spans the width of the corridor, the second is attached to it with self-drilling screws. The self-drilling screws are set at a maximum distance of 300 mm. The perimeter trims are suspended from the plenum with attachment brackets and threaded rods at a distance of max. 600 mm. The distance from the corner to the first suspension point should be max. 200 mm. In order to keep the perimeter trims in position, an angle bracing is attached using a primary angle at an angle of 30 to 45°. This is attached to the plenum at the top with an attachment bracket, using a M6 bolt. The end is cut at the bottom and bent to the required angle and attached to the perimeter trims with an M6 nut and bolt.

D1 - Transition with perimeter trims

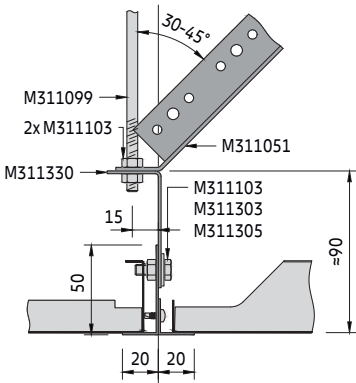

D2 - Transition with shadowline trims

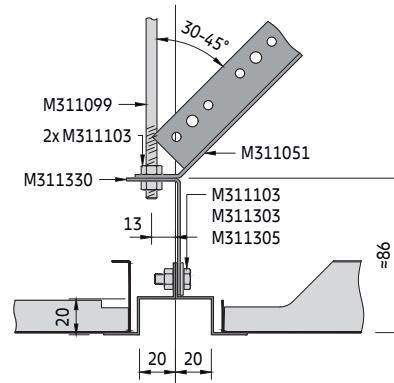

D3 - Transition with 2x perimeter trim, example with RA 1 / RA 2

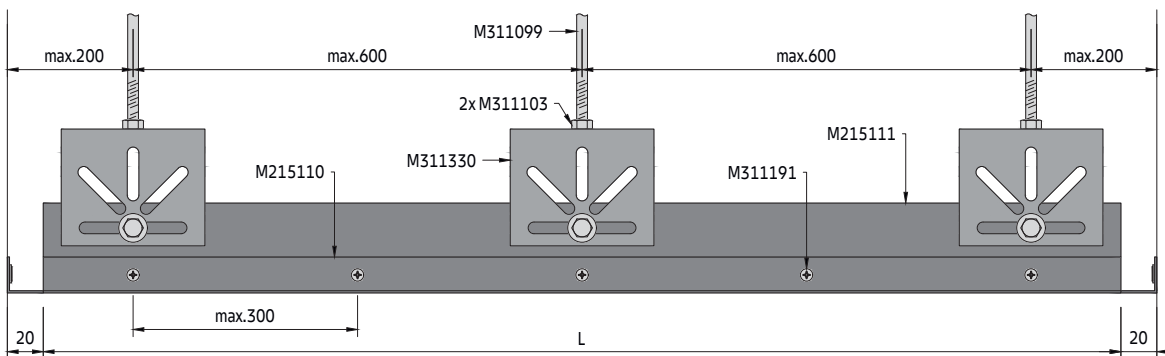

D4 - Transition example with RA 1 / RA 2

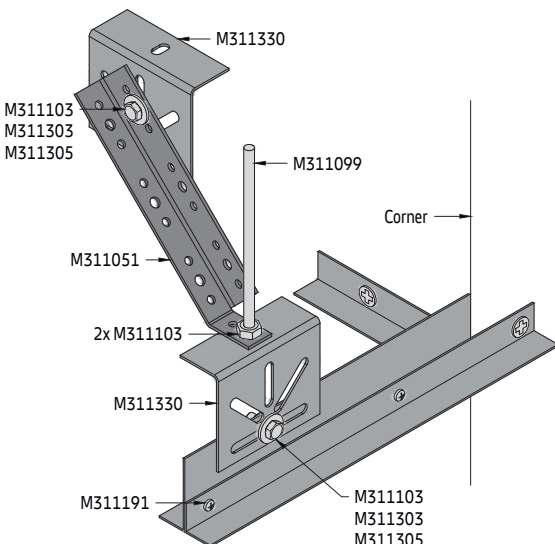

D5 - Transition example with RA 3

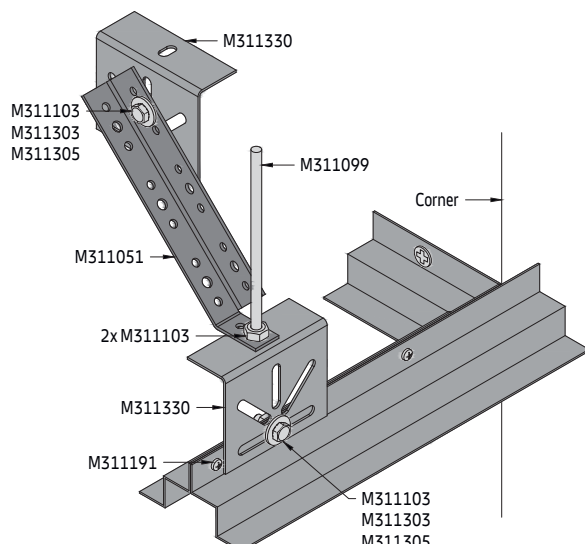

T-junction

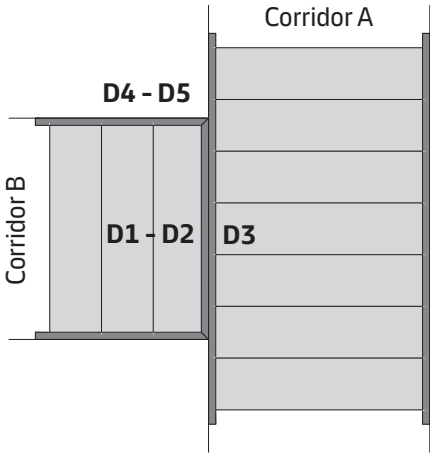

Corridor A runs through, corridor B connects to it and forms a T-junction.

Corner 1
with RA 1

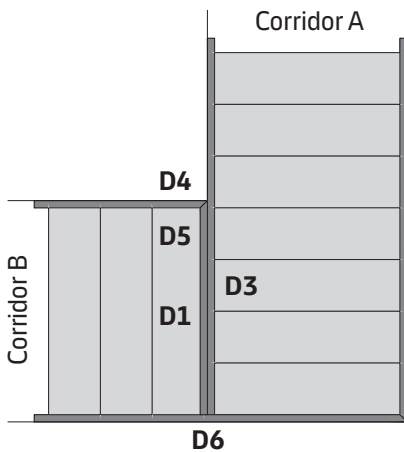

Corridor A runs to the end, corridor B connects to it and forms a transition. This solution is recommended for L-perimeter trims.

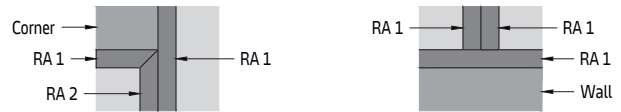

Corner 2
with RA 3

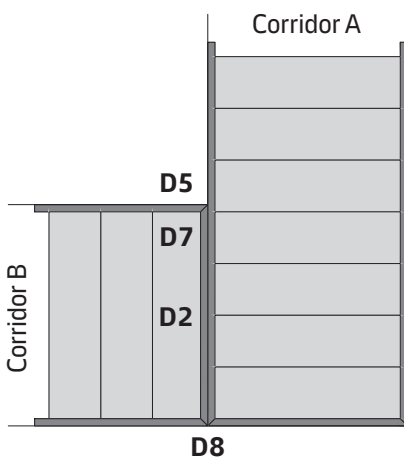

Corridor A runs to the end, corridor B connects to it and with forms a transition. This solution is recommended for shadowline perimeter trims. Each corridor is completely framed by a shadowline perimeter trim

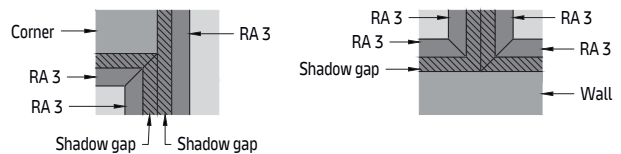

METAL F-Clip

Wall bracket + half DP12 A-Bar secondary grid
Concealed grid corridor solution for indoor applications

General information

- Concealed clip-in grid system for corridors
- Wall bracket (black coated) and half DP12 A-Bar made of galvanised steel
- Typical ceiling weight 8.6 - 9.5 kg/m² (indicative value for unperforated panels, without additional load)
- With variable shadow gap along the walls
- Panels are easily installed and fully demountable
- Optional swing-down function ACCESS
- Optional security clips available

Isometric view

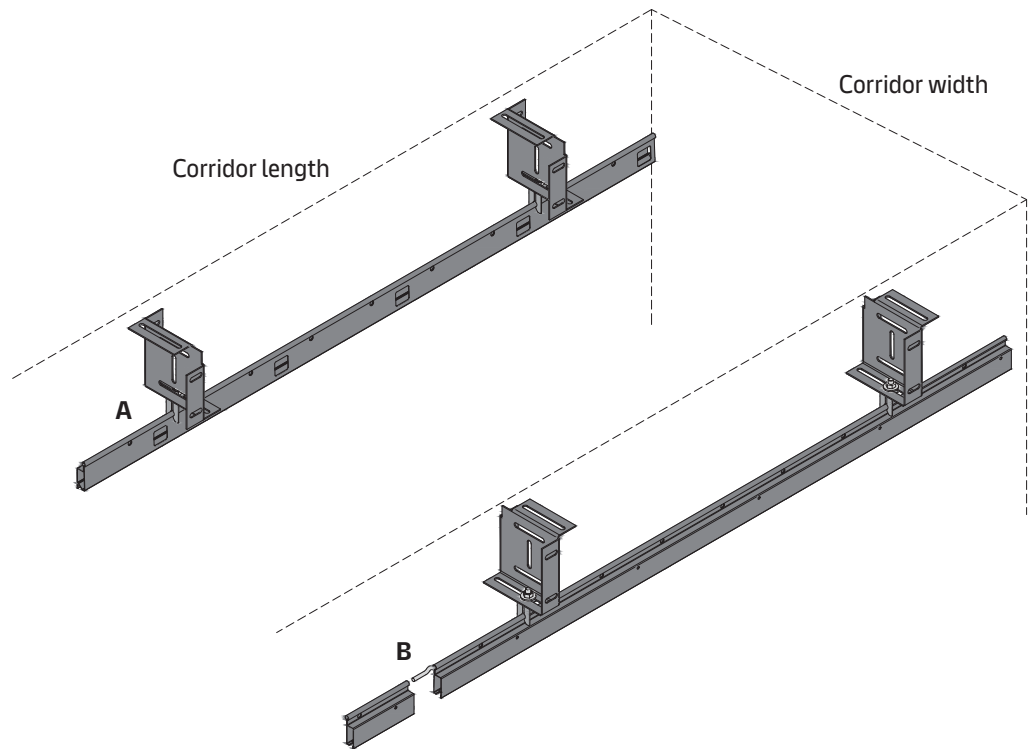

Vario Design layout options

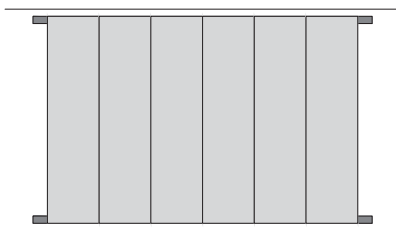

Wall bracket

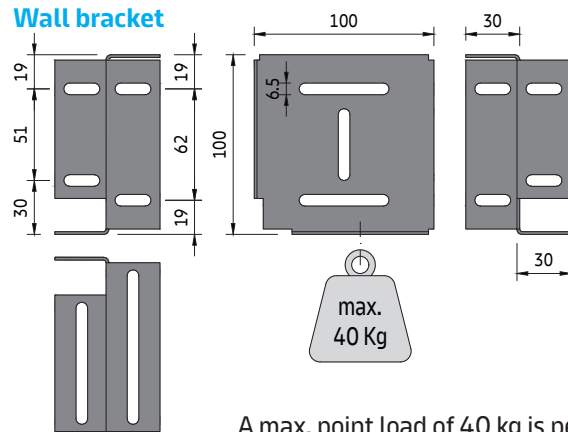

A max. point load of 40 kg is permitted.

Section C

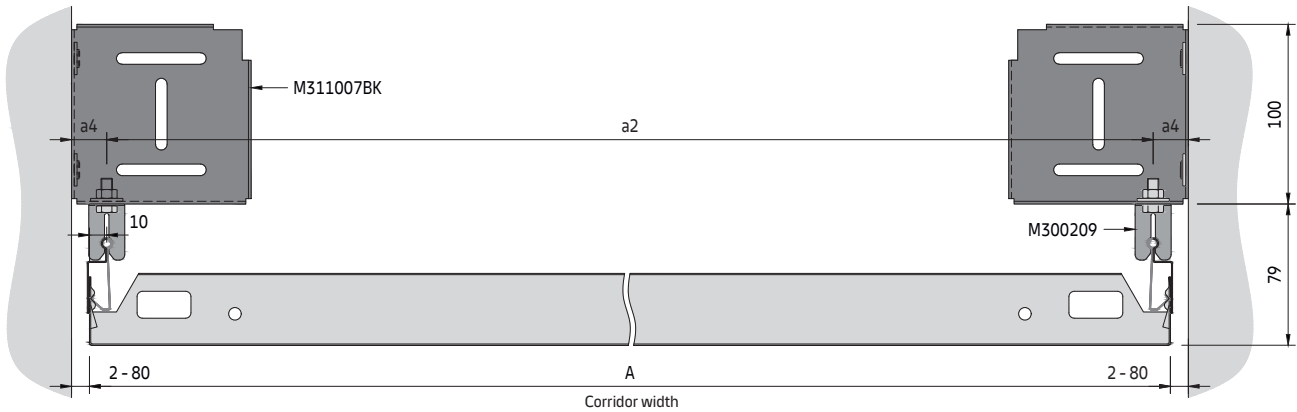

Section D

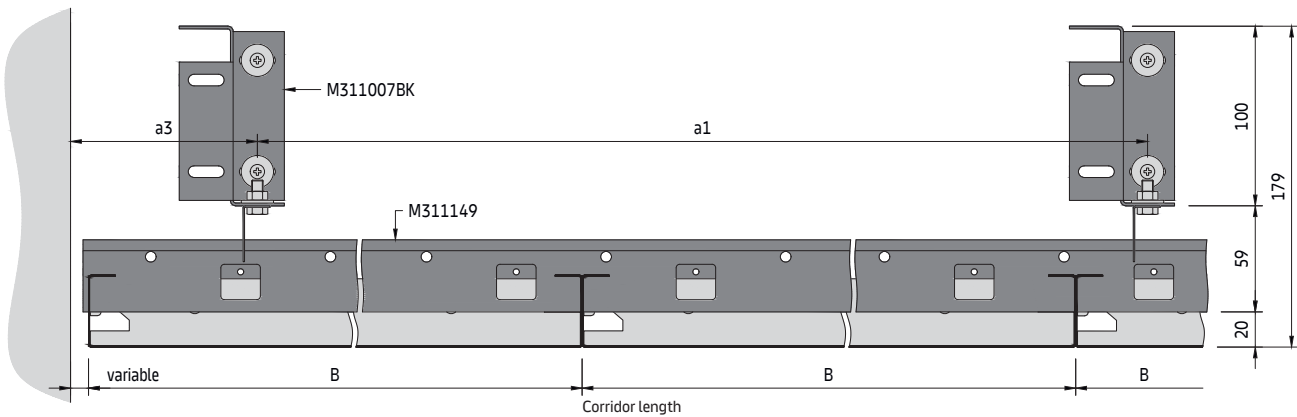

Grid components

Standard components

- M311007BK Wall bracket
- M311149 Half DP12 A-Bar
- M300138 Connection pin for DP12 A-Bar
- M300209 Hanger for DP12 A-Bar
- M311103 Hexagonal nut M6
- M311105 Washer
- M311303 Hexagonal bolt M6 x 16 mm

Optional components

- M300106 Security clip
- M311028 Extraction tool
- M300189 Swing down clip for ACCESS function (half DP12 A-Bar)
- M311051 Primary angle 3000 x 27 x 22 mm
- M311099 Threaded rod M6 x 1000 mm
- M215110 RA 1 perimeter trim 4000 x 20 x 20 mm RAL 9010

Half DP12 A-Bar secondary grid

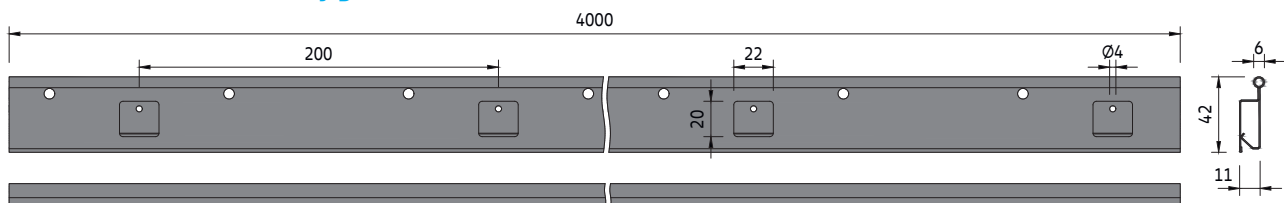

Spacing

a2 [mm]	System without additional load a1 [mm]	System with additional load +4 kg/m ² a1 [mm]
1000	1450	1450
1050	1400	1400
1100	1400	1400
1150	1350	1350
1200	1300	1300
1250	1300	1300
1300	1250	1250
1350	1250	1250
1400	1200	1200
1450	1200	1200
1500	1200	1200
1550	1150	1150
1600	1150	1150
1650	1100	1100
1700	1100	1100
1750	1100	1100
1800	1100	1100
1850	1050	1050
1900	1050	1050
1950	1050	1050
2000	1000	1000
2050	1000	1000
2100	1000	1000
2150	1000	1000
2200	950	950
2250	950	950
2300	950	950
2350	950	950
2400	950	950
2450	900	900
2500	900	900

Parameters

- a1 Distance of wall brackets
- a2 Distance between half DP12 A-Bars fixing points = A - 20 mm
- a3 Distance from wall = max. 200 mm
- a4 Variable distance from wall to half DP12 A-Bar fixing point
- M Module size = panel length / panel width
- A Panel length = min. 600 / max. 2500 mm
- B Panel width = min. 250 / max. 600 mm

Typical grid layout

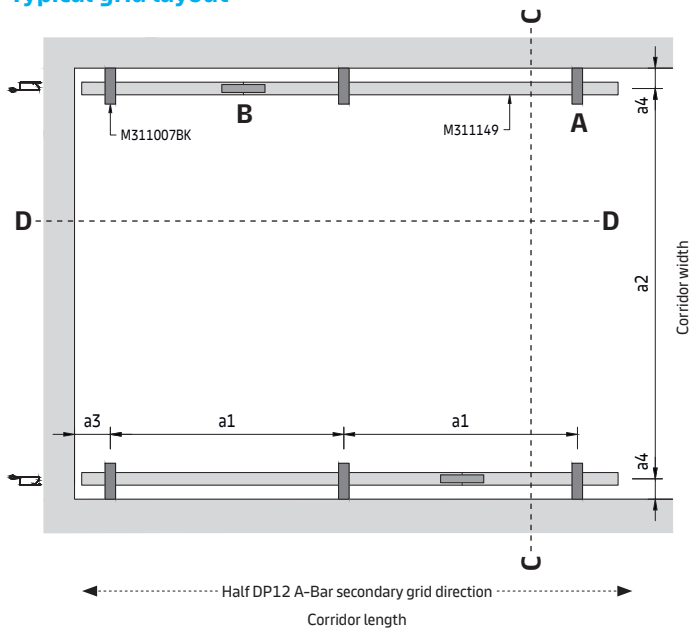

To determine suspension layout

The panel length (A) of the requested ceiling -20 mm is equal to the distance between the half DP12 A-Bar centres (a2).

On the appropriate spacing table, read down the column headed (a2) to the required panel length then read across to determine the wall bracket spacing (a1).

The shown values are maximum allowed distances and can be reduced but not exceeded.

METAL F-Clip
D02.401

Detail A
Hanger installation

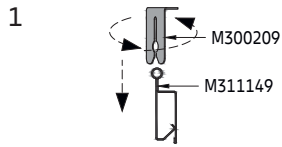

The hanger for half DP12 A-Bar is made of spring steel and is therefore elastic. It is twisted on the half DP12 A-Bar from above. Then it can be slid to the correct position.

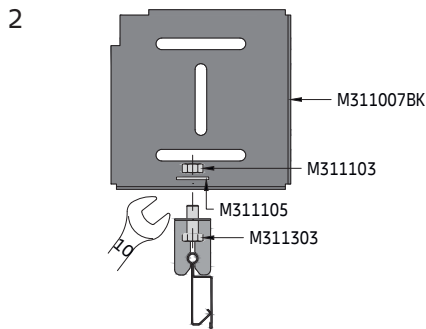

Fix the half DP12 A-Bar with fasteners below the wall bracket.

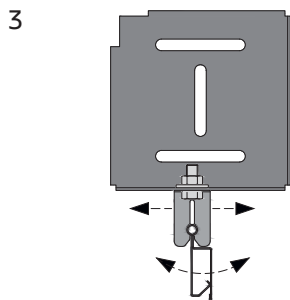

The half DP12 A-Bar is now locked in position. Due to the round head of the half DP12 A-Bar, it can swing. This is important because it allows any tolerances to be compensated.

Detail B
Splice connection

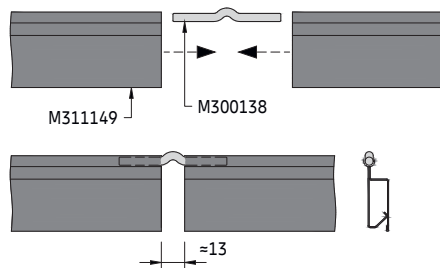

Insert the connection pin at the ends of the half DP12 A-Bars and connect them. There is a gap between the half DP12 A-Bars. The half DP12 A-Bars must be aligned so that the joint is not in the same place as the pips on the panels.

Detail E

Panel insertion

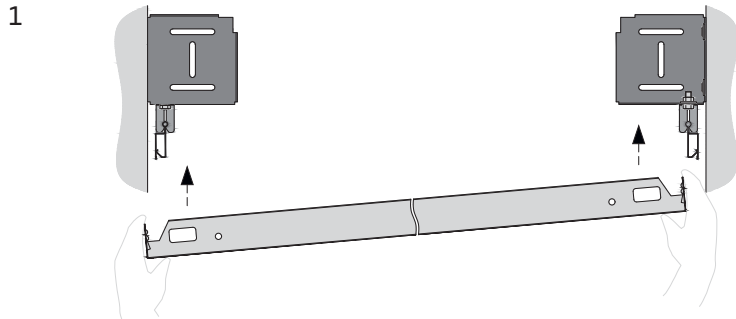

Take the panel and carefully insert it into the half DP12 A-Bars from below. All panels feature a double row of pips. The upper pip is inserted into the half DP12 A-Bar, the lower one serves as a stop. Be careful with the Panels. Always press along the edges with the pips and never on the transverse sides, otherwise the panels may be damaged. The panels should always be laid in such a way that the WINDOW hooks point in the same direction.

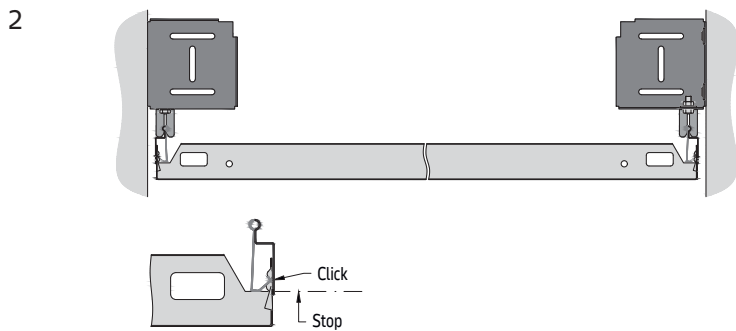

The panels are correctly inserted when all four corners are flush with the neighbouring panels. The panels are designed to match the half DP12 A-Bar. If third party profiles are used there is a high probability the tiles will not be correctly inserted.

Panel extraction

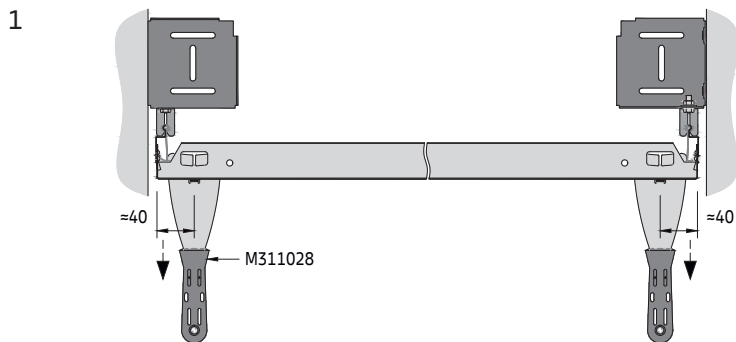

The panels are designed in such a way that the extraction tool can only be inserted in the designated places so that it clicks into place. There is a rectangular cut-out on the panels. It is therefore important that the appropriate extraction tool is used. This prevents damage to the panels. Insert on one side first and pull down with a gentle tug, followed by the opposite side.

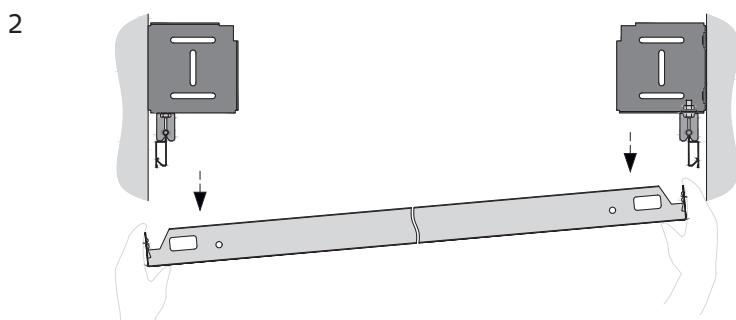

Remove it downwards and store the panel in a safe place so that it cannot be damaged.

METAL F-Clip
D02.401

Detail F

Optional security clip

The security clip serves to secure the panels and prevents them from being removed.

Panel locking

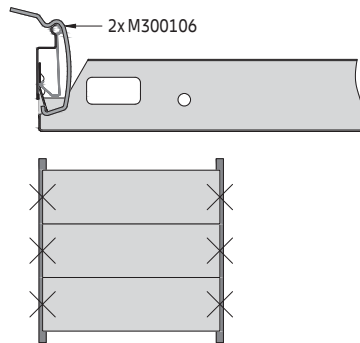

The panels have, on the sides where the pips are, an embossing where the security clip can be fixed. First hook the security clip into the embossing on the panel and then slip the upper end over the half DP12 A-Bar. Two security clips are required per panel.

Either individual panels or the entire ceiling can be secured. The panels are inserted and secured immediately. The last panel cannot be locked.

Detail G

Optional ACCESS swing-down function

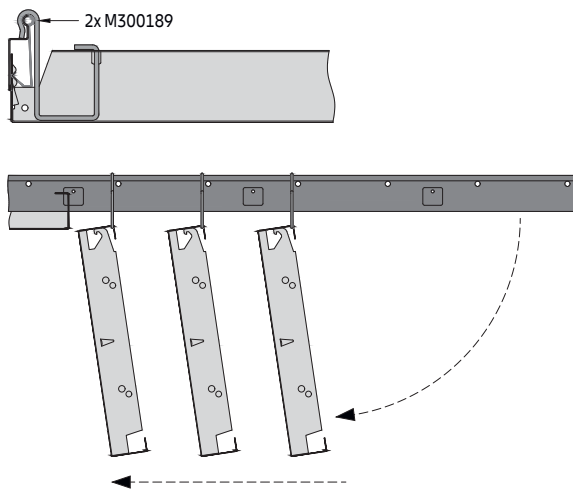

The panels are hinged-down from the long side. Up to three adjacent panels can be suspended at once. Do not exceed this number, otherwise the weight would be too high on the half DP12 A-Bar. The panels are installed in the same direction (HOOK detail).

The panels are provided with two small holes, which are used to insert the ACCESS swing-down clip. Once the clips are inserted, hook the panel on the half DP12 A-Bar. Two clips per panel are needed.

The ceiling is accessed with the extraction tool, as shown under detail D.

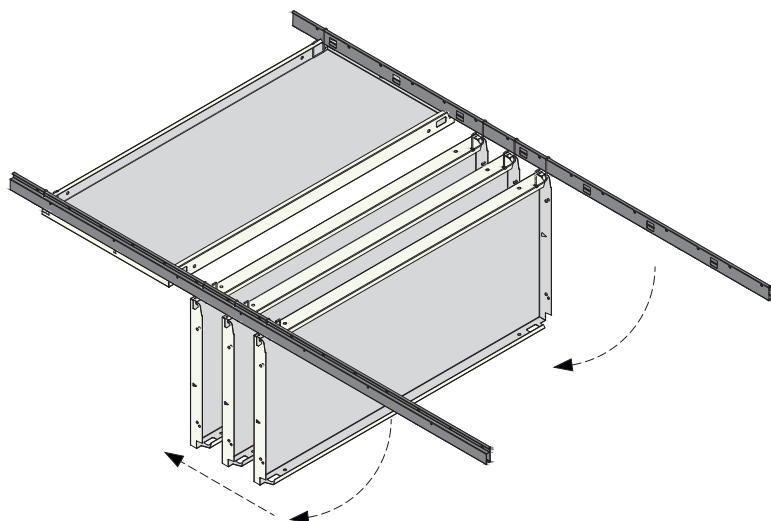

Detail H

Optional perimeter trim for cut panels

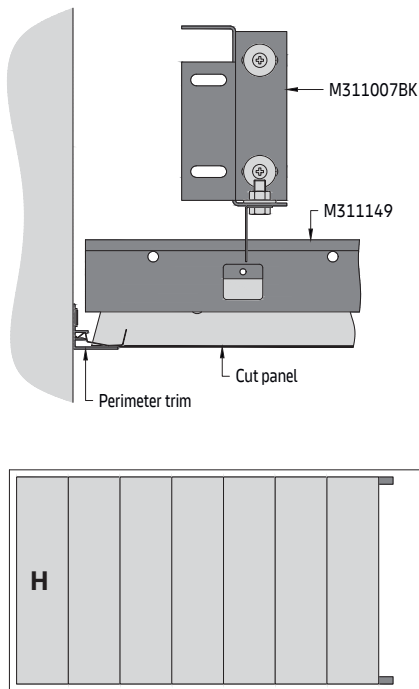

The last panel at the end of the corridor can be made to measure. A cost-effective alternative is to use a perimeter trim. This allows panels to be cut to size on site. See separate document for perimeter trim options.

Detail I

Optional perimeter trim for shadow gap

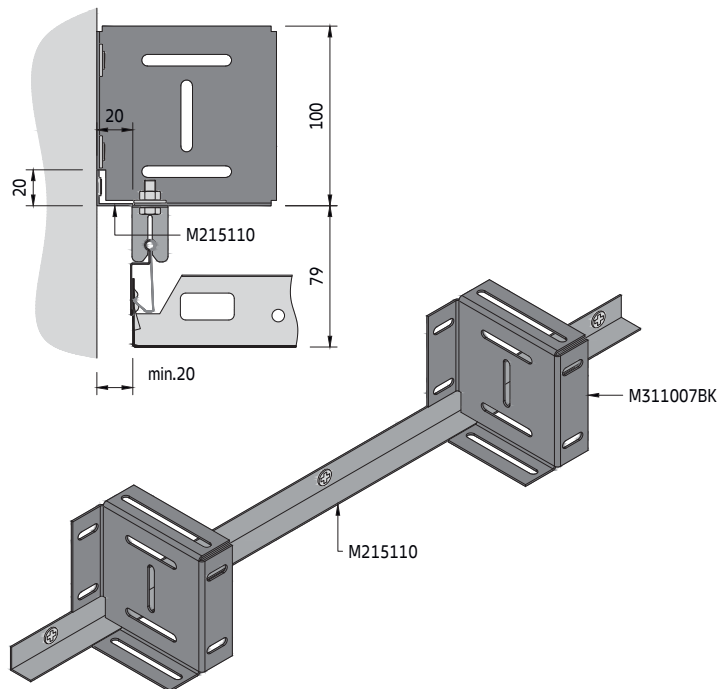

The shadow gap remains open in the standard version. Optionally, this can be covered with a perimeter trim. The perimeter trim is attached at the correct height so that the wall brackets can be placed on it and then attached to the wall.

Material required per m² (no waste included)
System without additional load [pcs/m²]

Components		a2 [mm]	1200	1400	1600	1800	2000	2200	2400	2500
M300138	Connection pin for DP12 A-Bar		0.42	0.36	0.31	0.28	0.25	0.23	0,21	0,20
M300209	Hanger for DP12 A-Bar		1.28	1.19	1.09	1.01	1.00	0.96	0.88	0.89
M311007BK	Wall bracket		1.28	1.19	1.09	1.01	1.00	0.96	0.88	0.89
M311103	Hexagonal nut M6		1.28	1.19	1.09	1.01	1.00	0.96	0.88	0.89
M311105	Washer		1.28	1.19	1.09	1.01	1.00	0.96	0.88	0.89
M311149	Half DP12 A-Bar		0.42	0.36	0.31	0.28	0.25	0.23	0.21	0.20
M311303	Hexagonal bolt M6 x 16 mm		1.28	1.19	1.09	1.01	1.00	0.96	0.88	0.89

The shown quantities are theoretical and based on an ideal layout, without considering the actual room layout. The ideal layout is based on a calculation 100 m². This calculation does not allow any damage, spare nor wastage. The final quantities and type of suspension have to be checked before ordering. Soffit and wall fixings by others. Not including optional items and extraction tools.

Detail J

Suspension option by double threaded rod

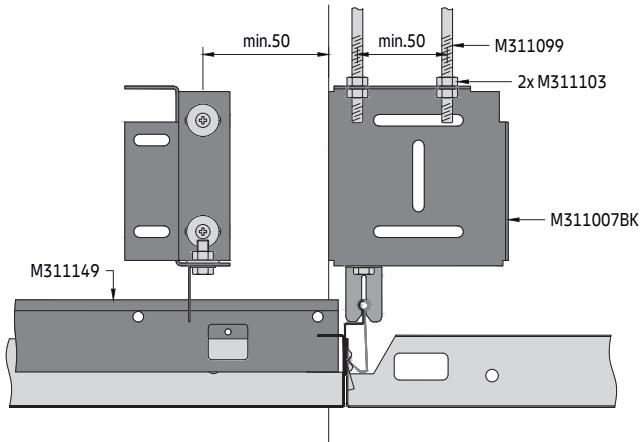

Suspension option by threaded rod with angle bracing

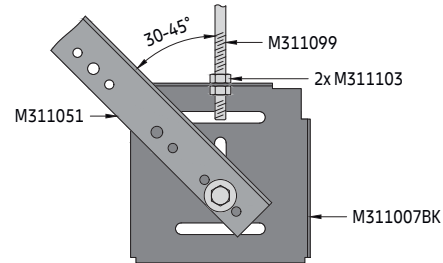

In these situations, the wall bracket can be suspended either with two threaded rods or one threaded rod and fixed by an angle bracing.

T-junction

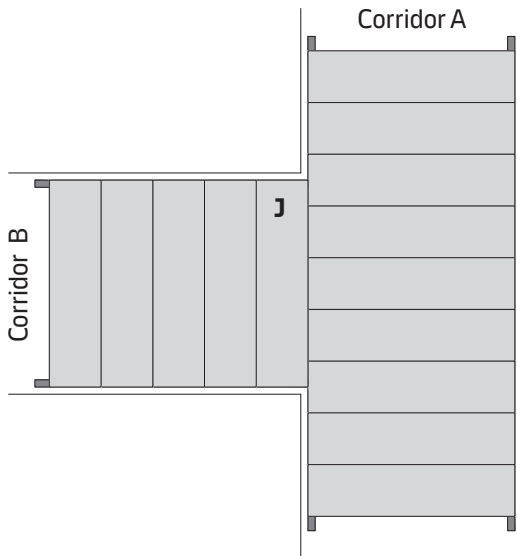

Corridor A runs through, corridor B connects to it and forms a T-junction.

Corner

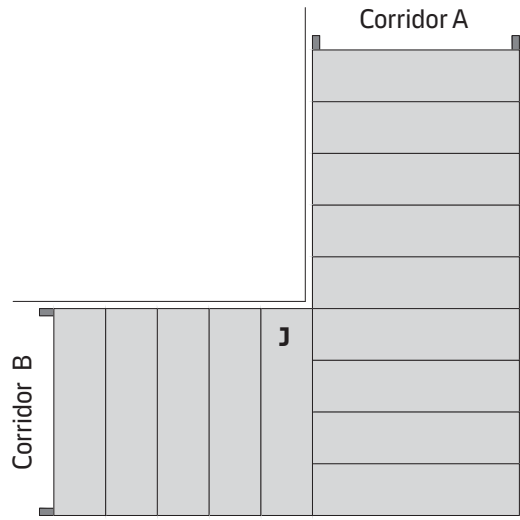

Corridor A runs to the end, corridor B connects to it and forms a transition.

METAL F-Clip

Wall bracket + DP12 A-Bar secondary grid
Concealed grid corridor solution for indoor applications

General information

- Concealed clip-in grid system for corridors
- Wall bracket (black coated) and DP12 A-Bar made of galvanised steel
- Typical ceiling weight 8.6 - 9.5 kg/m² (indicative value for unperforated panels, without additional load)
- With variable shadow gap along the walls
- Panels are easily installed and fully demountable
- Optional swing-down function ACCESS
- Optional security clips available

Isometric view

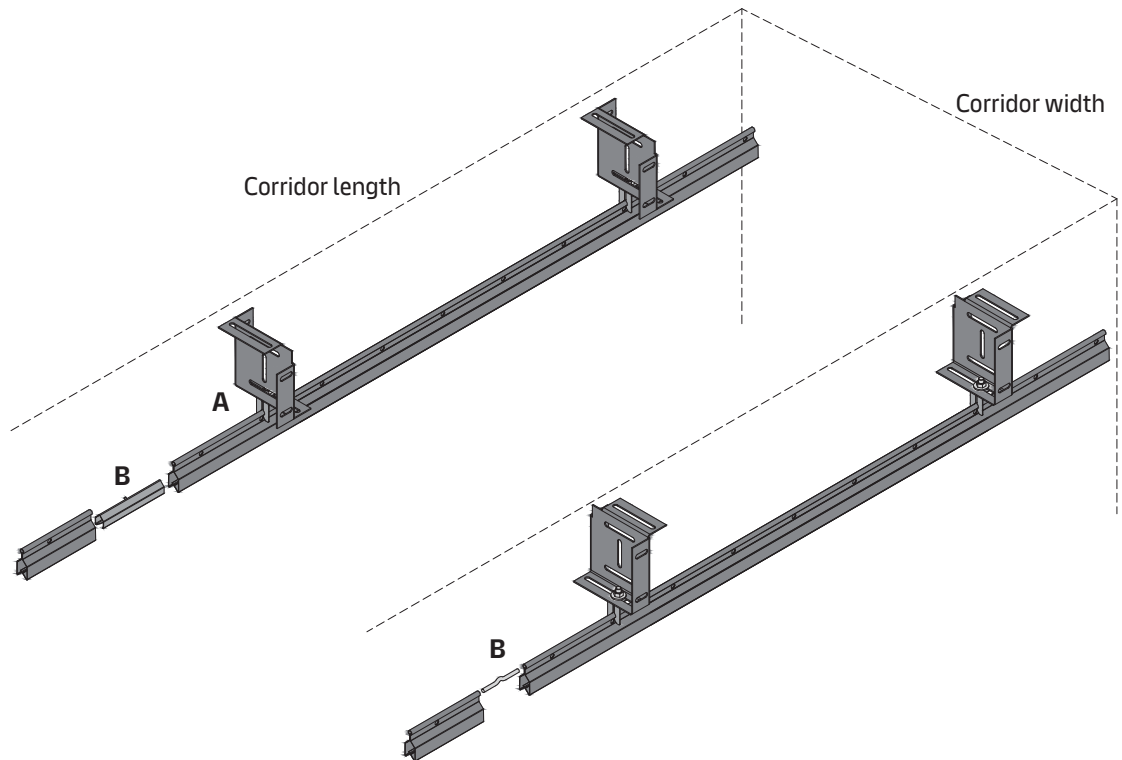

Vario Design layout options

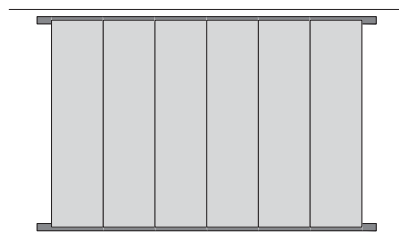

Wall bracket

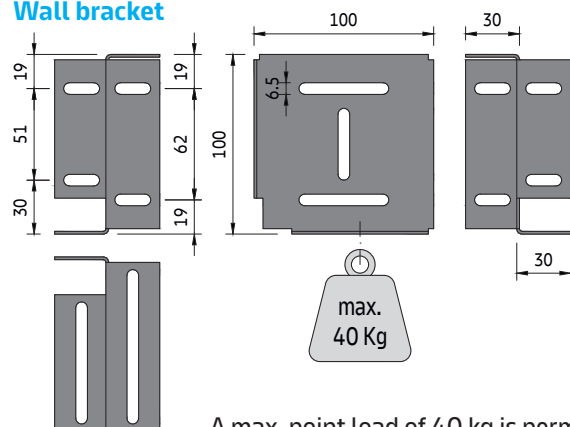

A max. point load of 40 kg is permitted.

Section C

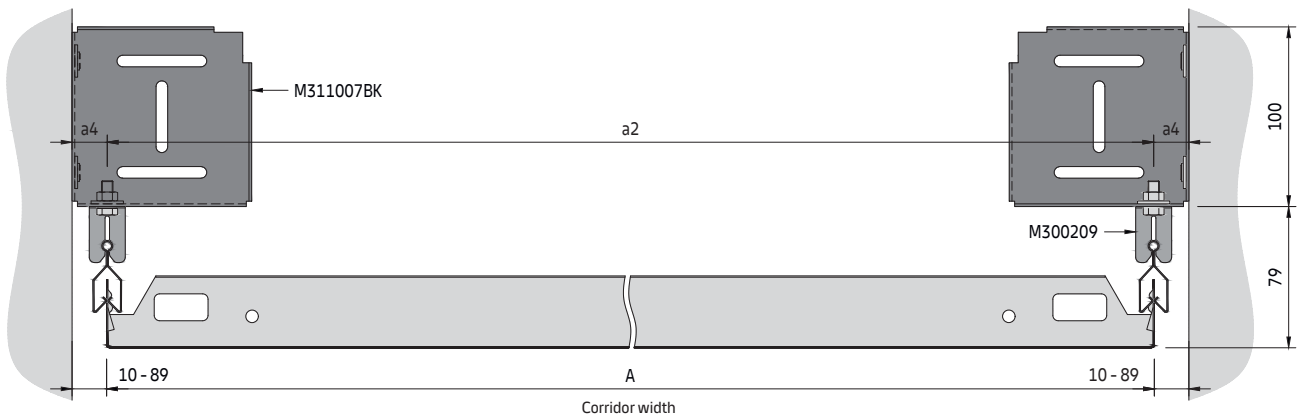

Section D

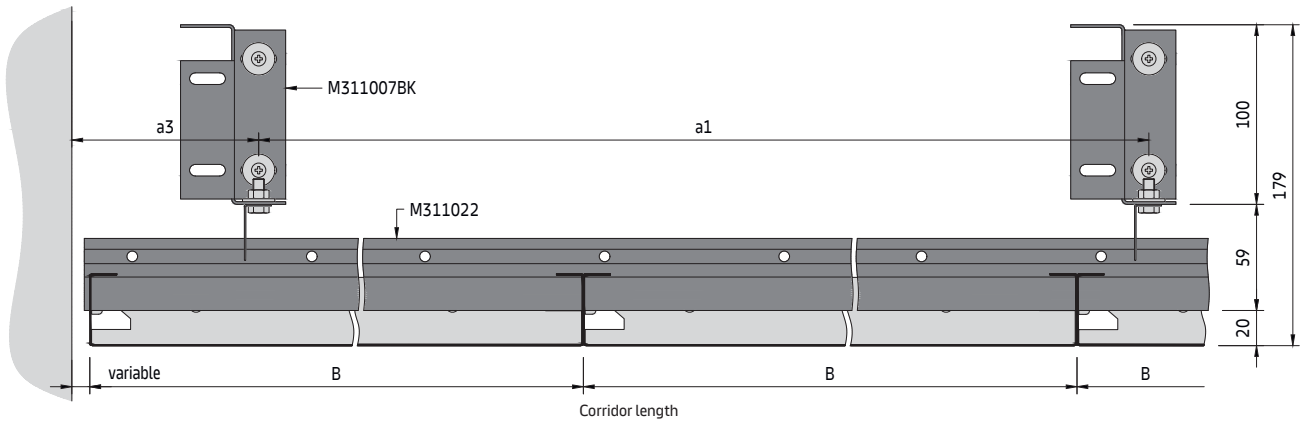

Grid components

Standard components

- M311007BK Wall bracket
- M300138 Connection pin for DP12 A-Bar
- M300209 Hanger for DP12 A-Bar
- M311022 DP12 A-Bar
- M311103 Hexagonal nut M6
- M311105 Washer
- M311303 Hexagonal bolt M6 x 16 mm

Optional components

- M300106 Security clip
- M311023 Splice connector for DP12 A-Bar
- M311028 Extraction tool
- M300188 Swing down clip for ACCESS function (DP12 A-Bar)
- M311051 Primary angle 3000 x 27 x 22 mm
- M311099 Threaded rod M6 x 1000 mm

DP12 A-Bar secondary grid

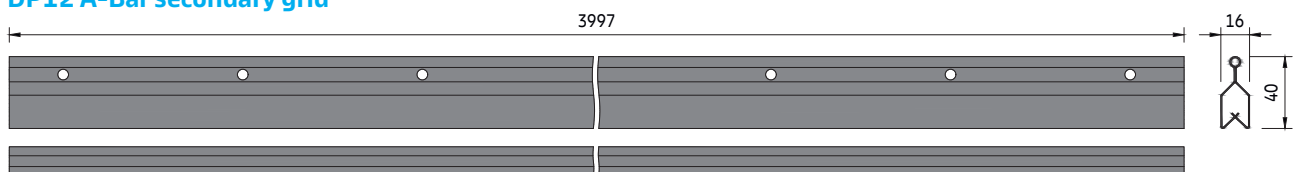

Spacing

a2 [mm]	System without additional load	System with additional load +4 kg/m ²
	a1 [mm]	a1 [mm]
1000	1600	1450
1050	1550	1400
1100	1550	1400
1150	1500	1350
1200	1450	1300
1250	1450	1300
1300	1400	1250
1350	1400	1250
1400	1350	1200
1450	1350	1200
1500	1300	1200
1550	1300	1150
1600	1250	1150
1650	1250	1100
1700	1250	1100
1750	1200	1100
1800	1200	1100
1850	1200	1050
1900	1150	1050
1950	1150	1050
2000	1150	1000
2050	1100	1000
2100	1100	1000
2150	1100	1000
2200	1100	950
2250	1050	950
2300	1050	950
2350	1050	950
2400	1050	950
2450	1050	900
2500	1000	900

Parameters

- a1 Distance of wall brackets
- a2 Distance between DP12 A-Bars fixing points
- a3 Distance from wall = max. 200 mm
- a4 Variable distance from wall to DP12 A-Bar fixing point
- M Module size = panel length / panel width
- A Panel length = min. 600 / max. 2500 mm
- B Panel width = min. 250 / max. 600 mm

Typical grid layout

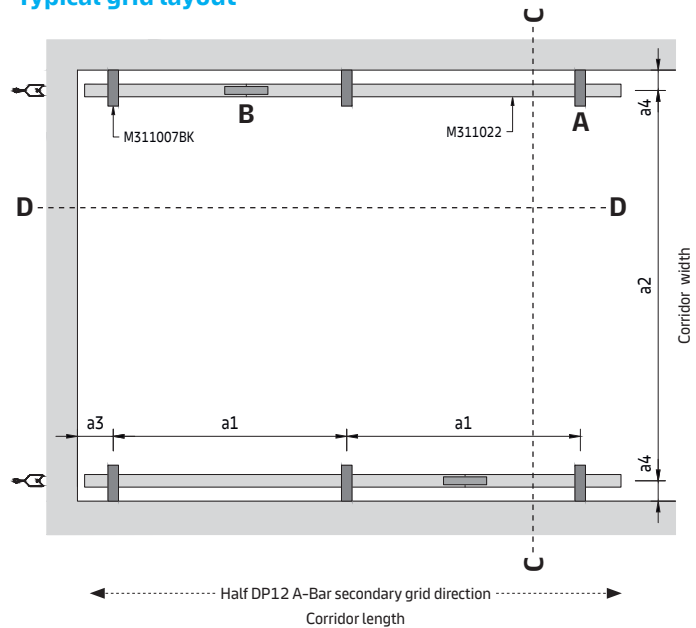

Parameters

The panel length (A) of the requested ceiling represents the known value and is therefore the starting point.

Take this length, which is equal to the distance between the secondary profiles (a2) and select the value for (a1) next to it.

The shown values are maximum allowed distances and can be reduced if needed.

METAL F-Clip
D02.401.1

Detail A
Hanger installation

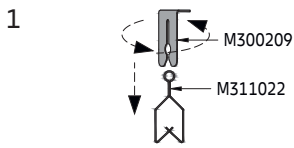

The hanger for DP12 A-Bar is made of spring steel and is therefore elastic. It is twisted on the DP12 A-Bar from above. Then it can be slid to the correct position.

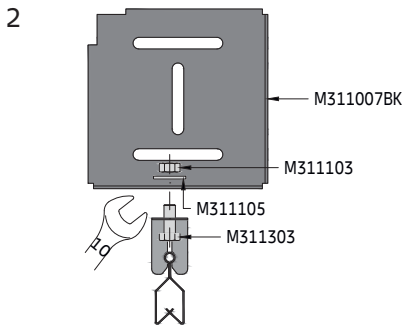

Fix the DP12 A-Bar with fasteners below the wall bracket.

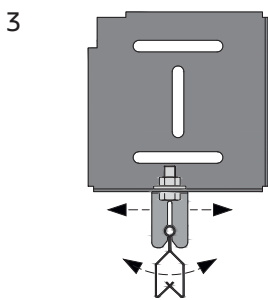

The DP12 A-Bar is now locked in position. Due to the round head of the DP12 A-Bar, it can swing. This is important because it allows any tolerances to be compensated.

Detail B
Splice connection

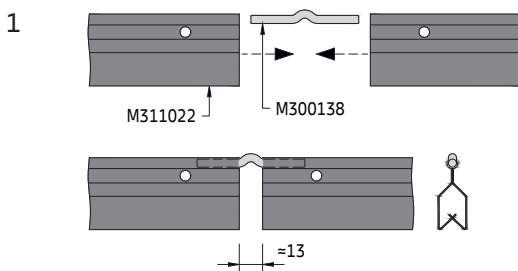

Insert the connection pin at the ends of the DP12 A-Bars and connect them. There is a gap between the DP12 A-Bars. The DP12 A-Bars must be aligned so that the joint is not in the same place as the pips on the tiles/panels.

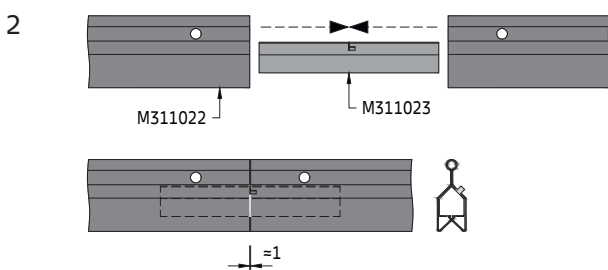

Optionally, the splice connector for DP12 A-Bar can be used. This is inserted at the ends of the DP12 A-Bars and an almost seamless connection is created.

METAL F-Clip
D02.401.1

Detail E

Panel insertion

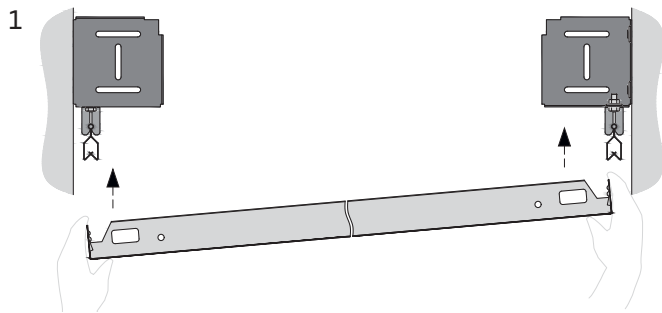

Take the panel and carefully insert it into the DP12 A-Bars from below. All panels feature a double row of pips. The upper pip is inserted into the DP12 A-Bar, the lower one serves as a stop. Be careful with the Panels. Always press along the edges with the pips and never on the transverse sides, otherwise the panels may be damaged. The panels should always be laid in such a way that the WINDOW hooks point in the same direction.

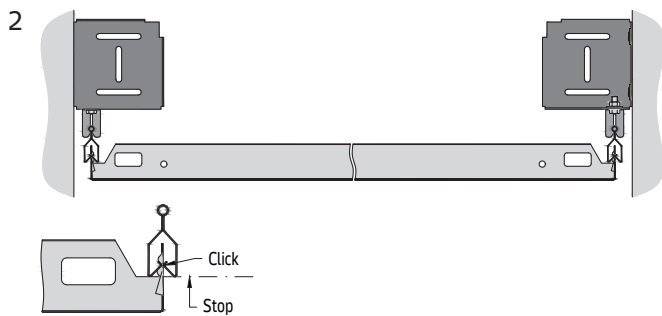

The panels are correctly inserted when all four corners are flush with the neighbouring panels. The panels are designed to match the DP12 A-Bar. If third party profiles are used there is a high probability the tiles will not be correctly inserted.

Panel extraction

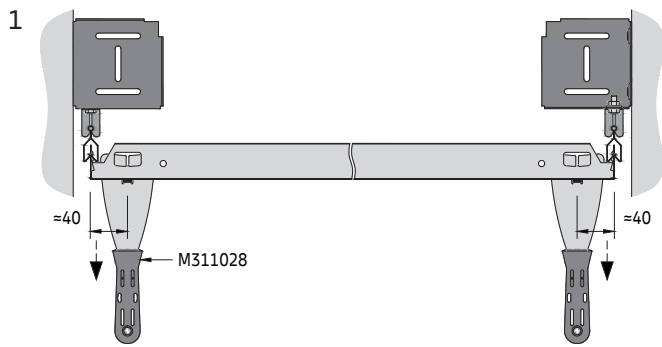

The panels are designed in such a way that the extraction tool can only be inserted in the designated places so that it clicks into place. There is a rectangular cut-out on the panels. It is therefore important that the appropriate extraction tool is used. This prevents damage to the panels. Insert on one side first and pull down with a gentle tug, followed by the opposite side.

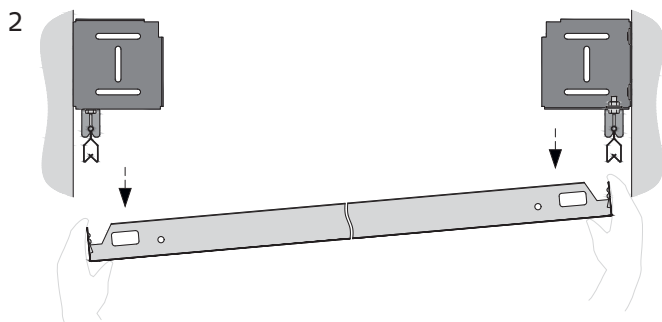

Remove it downwards and store the panel in a safe place so that it cannot be damaged.

METAL F-Clip
D02.401.1

Detail F

Optional security clip

The security clip serves to secure the panels and prevents them from being removed.

Panel locking

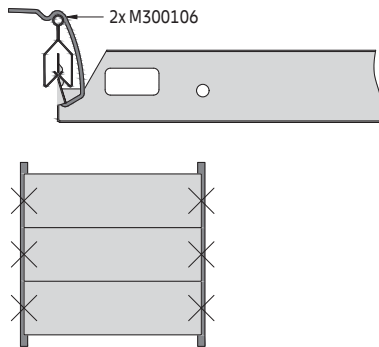

The panels have, on the sides where the pips are, an embossing where the security clip can be fixed. First hook the security clip into the embossing on the panel and then slip the upper end over the DP12 A-Bar. Two security clips are required per panel.

Either individual panels or the entire ceiling can be secured. The panels are inserted and secured immediately. The last panel cannot be locked.

Detail G

Optional ACCESS swing-down function

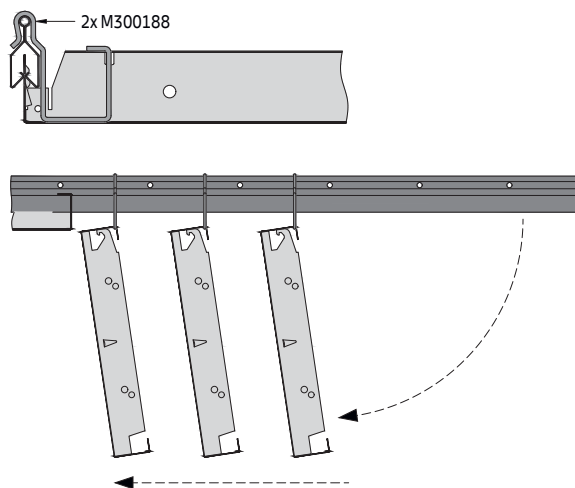

The panels are hinged-down from the long side. Up to three adjacent panels can be suspended at once. Do not exceed this number, otherwise the weight would be too high on the DP12 A-Bar. The panels are installed in the same direction (HOOK detail).

The panels are provided with two small holes, which are used to insert the ACCESS swing-down clip. Once the clips are inserted, hook the panel on the DP12 A-Bar. Two clips per panel are needed.

The ceiling is accessed with the extraction tool, as shown under detail D.

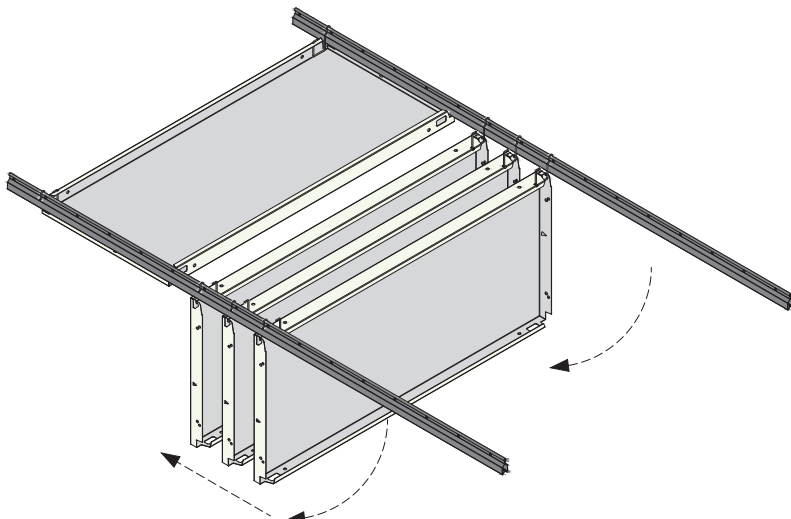

METAL F-Clip
D02.401.1

Detail H

Optional perimeter trim for cut panels

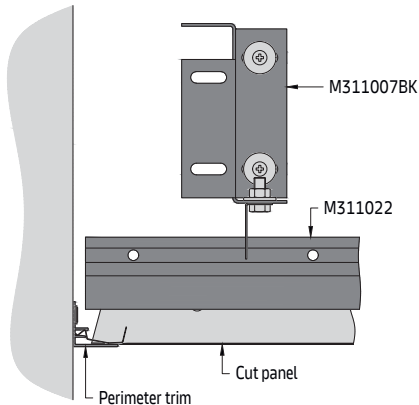

The last panel at the end of the corridor can be made to measure. A cost-effective alternative is to use a perimeter trim. This allows panels to be cut to size on site. See separate document for perimeter trim options.

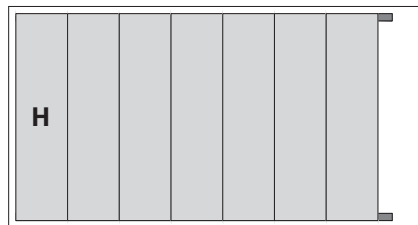

Material required per m² (no waste included)

System without additional load [pcs/m²]

Components		a2 [mm]	1200	1400	1600	1800	2000	2200	2400	2500
M300138	Connection pin for DP12 A-Bar		0.42	0.36	0.31	0.28	0.25	0.23	0.21	0.20
M300209	Hanger for DP12 A-Bar		1.15	1.06	1.00	0.93	0.87	0.83	0.79	0.80
M311007BK	Wall bracket		1.15	1.06	1.00	0.93	0.87	0.83	0.79	0.80
M311022	DP12 A-Bar		0.42	0.36	0.31	0.28	0.25	0.23	0.21	0.20
M311103	Hexagonal nut M6		1.15	1.06	1.00	0.93	0.87	0.83	0.79	0.80
M311105	Washer		1.15	1.06	1.00	0.93	0.87	0.83	0.79	0.80
M311303	Hexagonal bolt M6 x 16 mm		1.15	1.06	1.00	0.93	0.87	0.83	0.79	0.80

The shown quantities are theoretical and based on an ideal layout, without considering the actual room layout. The ideal layout is based on a calculation 100 m². This calculation does not allow any damage, spare nor wastage. The final quantities and type of suspension have to be checked before ordering. Soffit and wall fixings by others. Not including optional items and extraction tools.

METAL F-Clip
D02.401.1

Detail I

Suspension option by double threaded rod

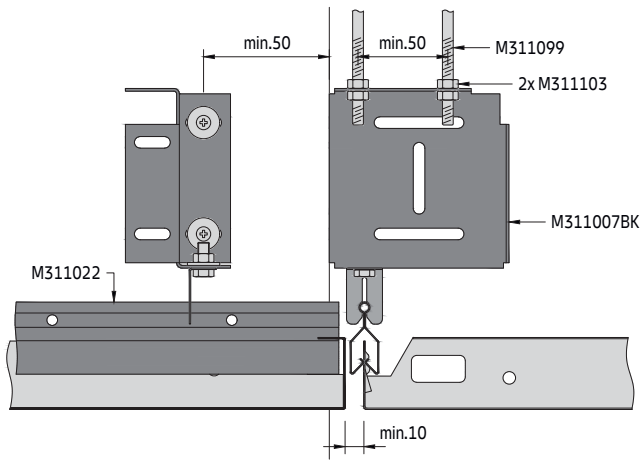

Suspension option by threaded rod with angle bracing

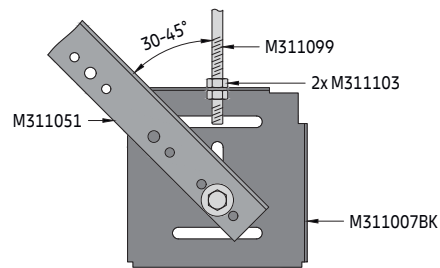

In these situations, the wall bracket can be suspended either with two threaded rods or one threaded rod and fixed by an angle bracing.

T-junction

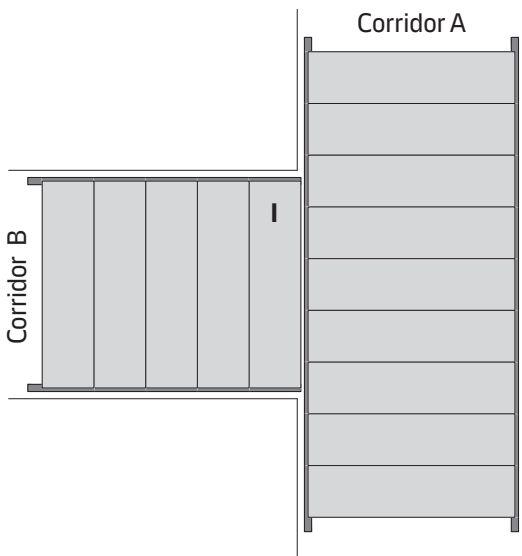

Corridor A runs through, corridor B connects to it and forms a T-junction.

Corner

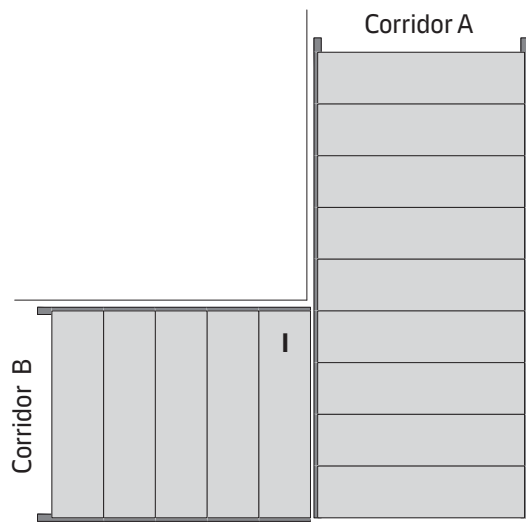

Corridor A runs to the end, corridor B connects to it and forms a transition.

METAL F-H 600

Wall bracket + J-Bar secondary grid

Concealed grid corridor solution for indoor applications

General information

- Concealed hook-on grid system for corridors
- Wall bracket (black coated) and J-Bar made of galvanised steel
- Typical ceiling weight 8.6 - 9.5 kg/m² (indicative value for unperforated panels, without additional load)
- With variable shadow gap along the walls
- Panels are easily installed and fully demountable
- Optional security brackets available
- Suitable for large panel sizes and chilled ceilings

Isometric view

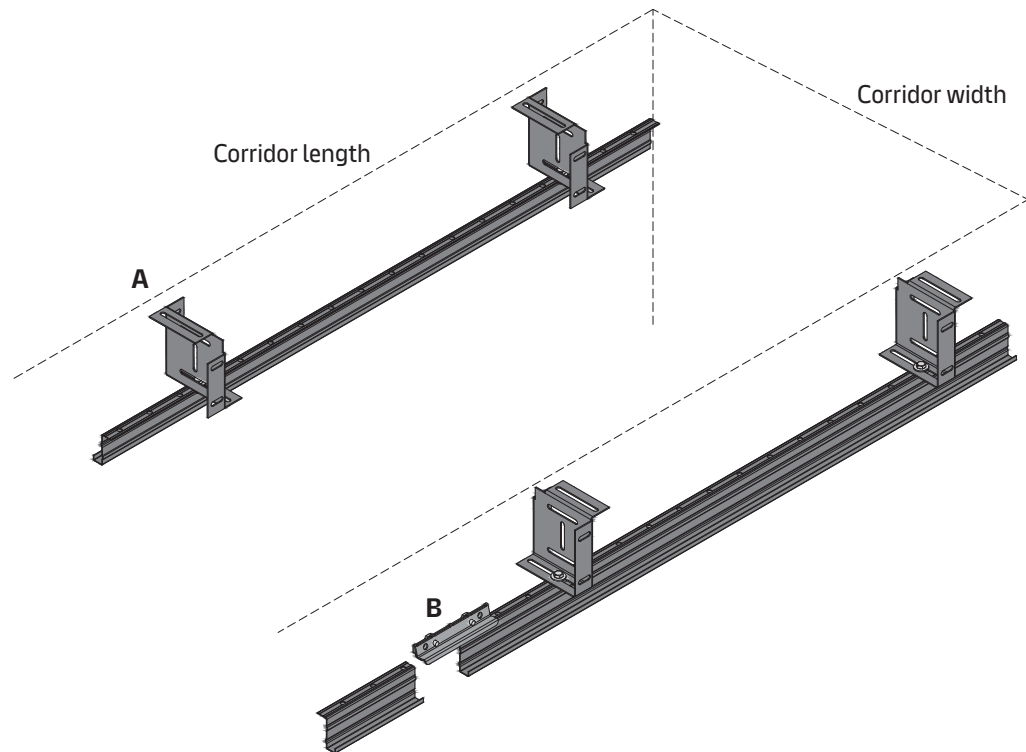

Vario Design layout options

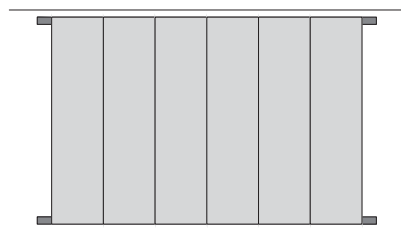

Wall bracket

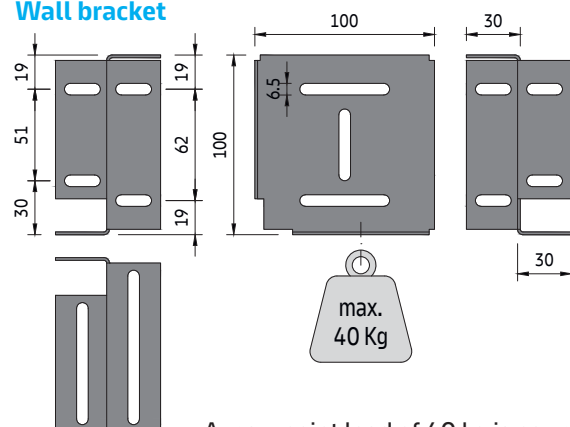

A max. point load of 40 kg is permitted.

Section C

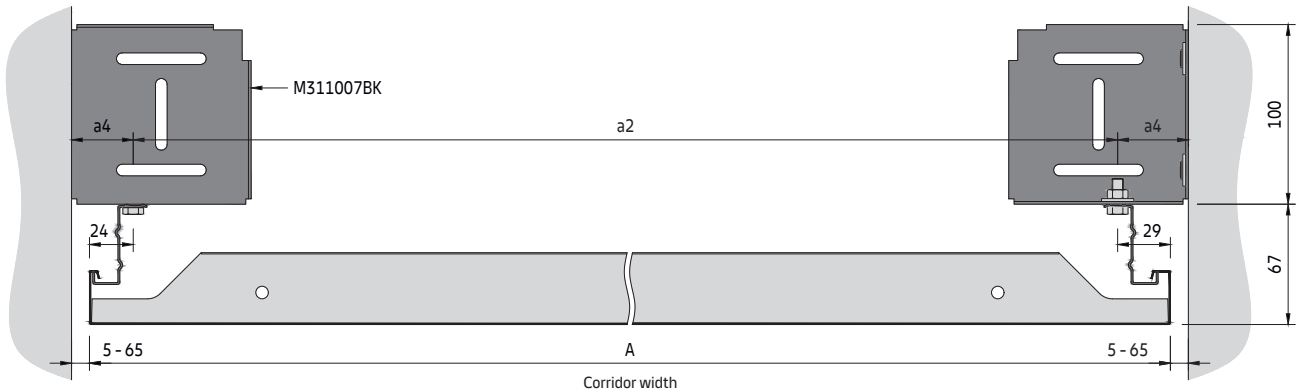

Section D

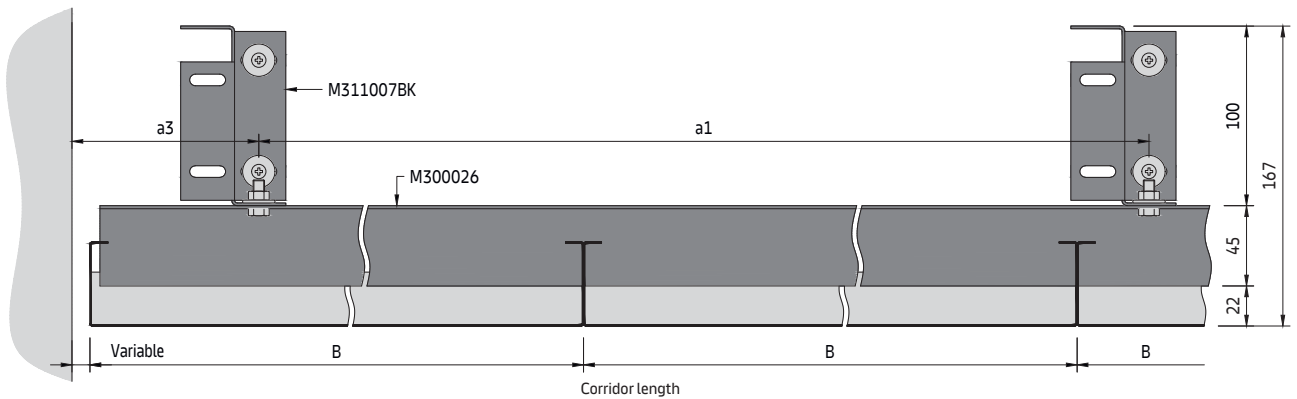

Grid components

Standard components

- M311007BK Wall bracket
- M300026 J-Bar
- M300307 Splice connector for J-Bar
- M311103 Hexagonal nut M6
- M311105 Washer
- M311303 Hexagonal bolt M6 x 16 mm

Optional components

- M311218 Security bracket
- M311191 Self-drilling screw 3.5 x 9.5 mm
- M311051 Primary angle 3000 x 27 x 22 mm
- M311099 Threaded rod M6 x 1000 mm
- M215110 RA 1 perimeter trim 4000 x 20 x 20 mm RAL 9010

J-Bar secondary grid

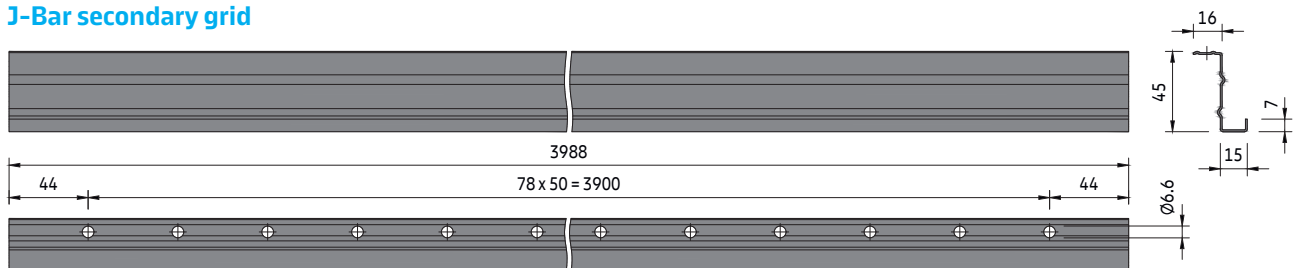

Spacing

a2 [mm]	System without additional load	System with additional load +4 kg/m ²
	a1 [mm]	a1 [mm]
1000	1750	1550
1050	1700	1500
1100	1650	1500
1150	1600	1450
1200	1600	1450
1250	1550	1400
1300	1550	1350
1350	1500	1350
1400	1450	1300
1450	1450	1250
1500	1400	1250
1550	1400	1250
1600	1400	1250
1650	1350	1200
1700	1350	1200
1750	1300	1200
1800	1300	1150
1850	1300	1150
1900	1250	1150
1950	1250	1100
2000	1250	1100
2050	1200	1100
2100	1200	1100
2150	1200	1050
2200	1150	1050
2250	1150	1050
2300	1150	1050
2350	1150	1000
2400	1100	1000
2450	1100	1000
2500	1100	1000
2600	1100	950
2700	1050	950
2800	1050	950
2900	1000	900
3000	1000	900
3100	1000	900
3200	950	850
3300	950	850

Parameters

- a1 Distance of wall brackets
- a2 Distance between J-Bars fixing points = A - 53 mm
- a3 Distance from wall = max. 200 mm
- a4 Variable distance from wall to J-Bar fixing point
- M Module size = panel length / panel width
- A Panel length = min. 600 / max. 3300 mm
- B Panel width = min. 247 / max. 1350 mm

Typical grid layout

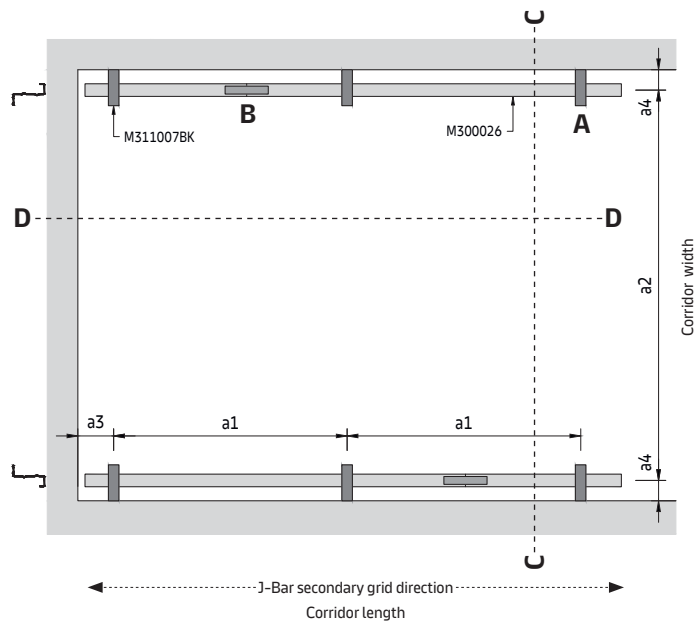

To determine suspension layout

The panel length (A) of the requested ceiling -53 mm is equal to the distance between the J-Bar centres (a2).

On the appropriate spacing table, read down the column headed (a2) to the required panel length then read across to determine the wall bracket spacing (a1).

The shown values are maximum allowed distances and can be reduced but not exceeded.

Detail A

J-Bar installation

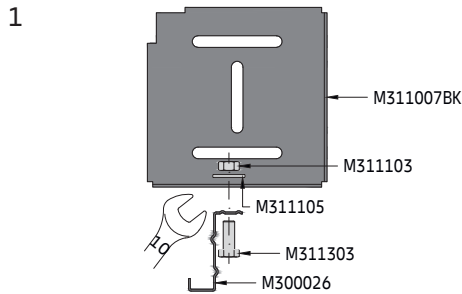

Fix the J-Bar with fasteners below the wall bracket.

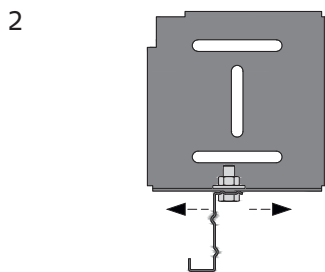

The J-Bar is now locked in position.

Detail B

Splice connection

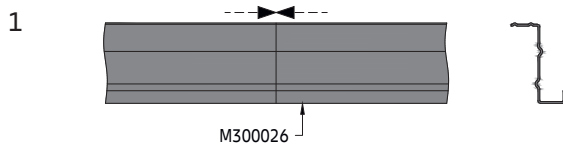

The ends of the J-Bars should be butt together without a gap.



The connectors for the J-Bars must be inserted from above without a gap.

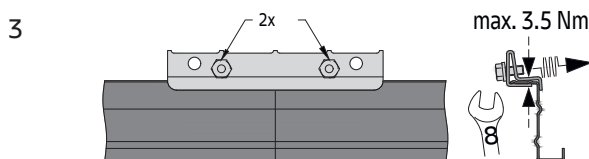

Use the bolts to secure the connector. Stagger the joints. from above without a gap.

Detail E

Panel insertion

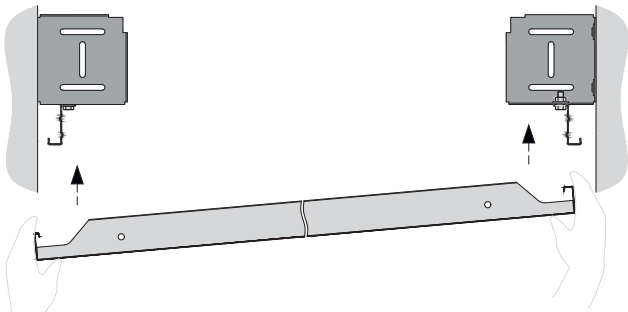
1  The panels are designed asymmetrically so that they can be hooked on effortlessly.

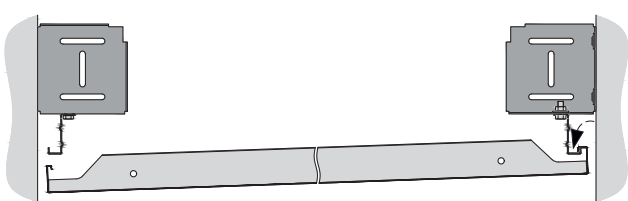
2  Hook the side with the wider hook edge detail into the J-Bar first.

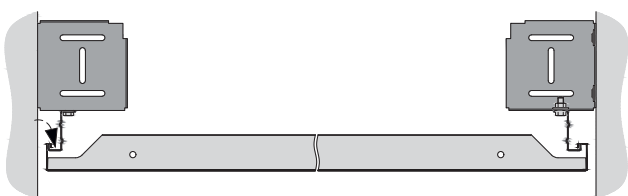
3  Followed by the side with the narrower hook edge detail.

Panel extraction

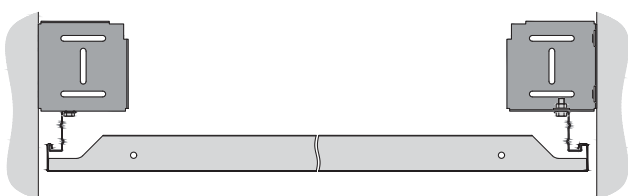
1  Followed by the side with the narrower hook edge detail.

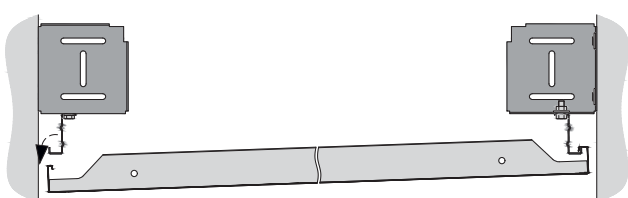
2  Followed by the side with the narrower hook edge detail.

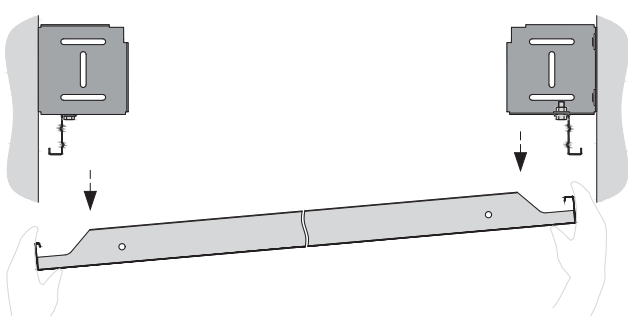
3  Followed by the side with the narrower hook edge detail.
Remove it downwards and store the panel in a safe place so that it cannot be damaged.

Detail F

Optional security bracket

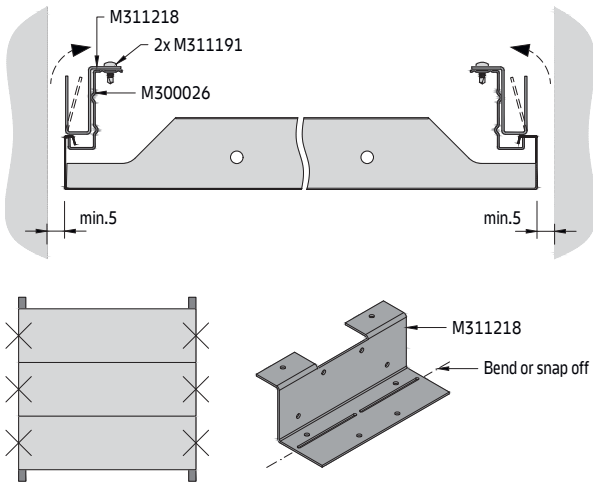

The security bracket serves to secure the panels and prevents them from being removed. The security bracket can be fixed to the J-Bar with two self-drilling screws. The easiest way is from above, but a minimum height is required for this. The bottom tab of the security bracket can either be bent up by hand or snapped off entirely.

Either individual panels or the entire ceiling can be secured. The panels are inserted and secured immediately. The last panel cannot be locked.

Detail G

Optional perimeter trim for cut panels

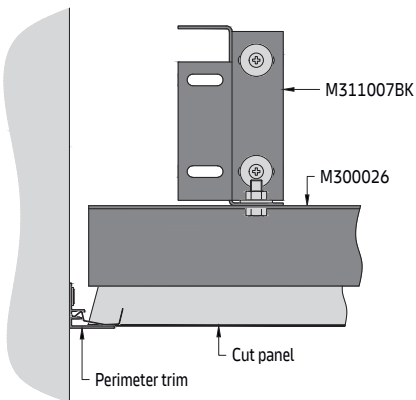

The last panel at the end of the corridor can be made to measure. A cost-effective alternative is to use a perimeter trim. This allows panels to be cut to size on site. See separate document for perimeter trim options.

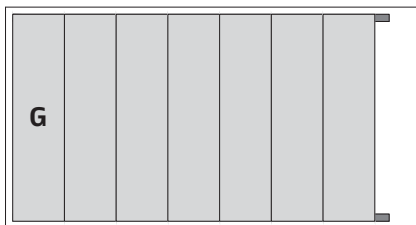

Detail H

Optional perimeter trim for shadow gap

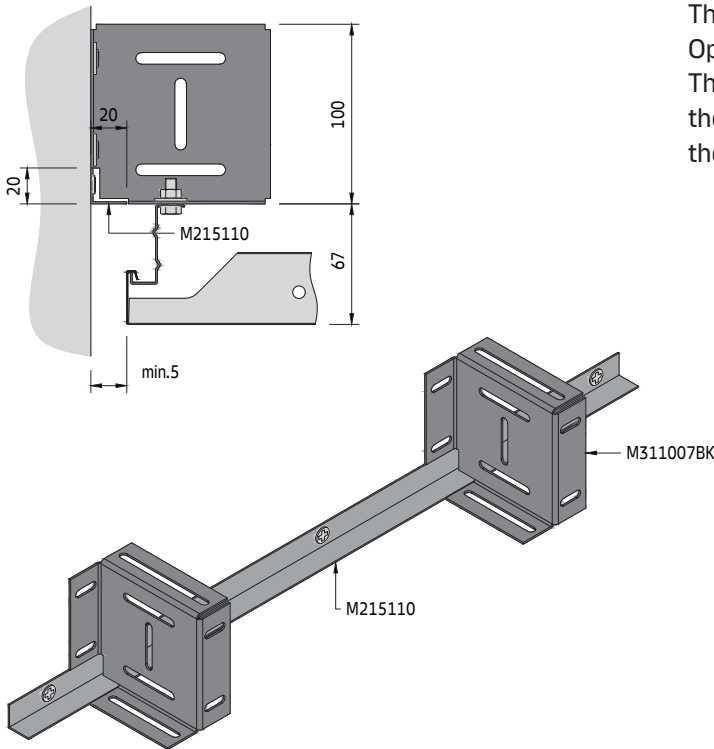

The shadow gap remains open in the standard version. Optionally, this can be covered with a perimeter trim. The perimeter trim is attached at the correct height so that the wall brackets can be placed on it and then attached to the wall.

Material required per m² (no waste included)

System without additional load [pcs/m²]

Components		a2 [mm]	1200	1600	1800	2000	2400	2800	3000	3300
M300026	J-Bar		0.42	0.31	0.28	0.25	0.21	0.18	0.17	0.15
M300307	Splice connector for J-Bar		0.42	0.31	0.28	0.25	0.21	0.18	0.17	0.15
M311007BK	Wall bracket		1.28	1.09	1.01	1.00	0.88	0.68	0.67	0.64
M311103	Hexagonal nut M6		1.28	1.09	1.01	1.00	0.88	0.68	0.67	0.64
M311105	Washer		1.28	1.09	1.01	1.00	0.88	0.68	0.67	0.64
M311303	Hexagonal bolt M6 x 16 mm		1.28	1.09	1.01	1.00	0.88	0.68	0.67	0.64

The shown quantities are theoretical and based on an ideal layout, without considering the actual room layout. The ideal layout is based on a calculation 100 m². This calculation does not allow any damage, spare nor wastage. The final quantities and type of suspension have to be checked before ordering. Soffit and wall fixings by others. Not including optional items and extraction tools.

Detail I

Suspension option by double threaded rod

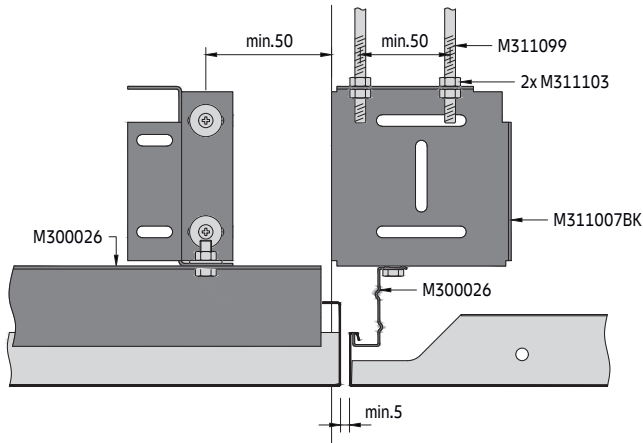

Suspension option by threaded rod with angle bracing

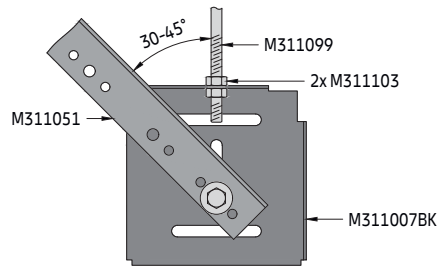

In these situations, the wall bracket can be suspended either with two threaded rods or one threaded rod and fixed by an angle bracing.

T-junction

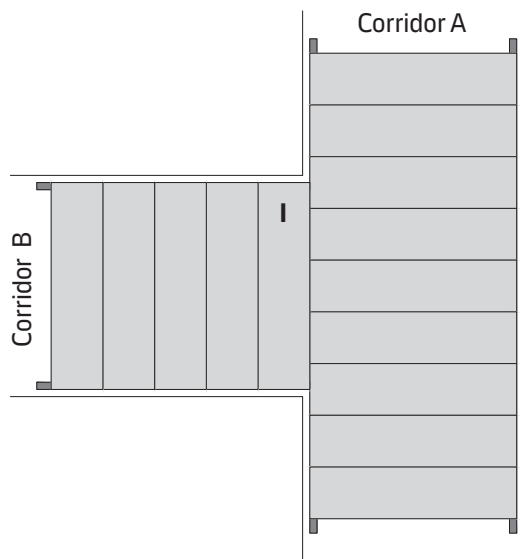

Corridor A runs through, corridor B connects to it and forms a T-junction.

Corner

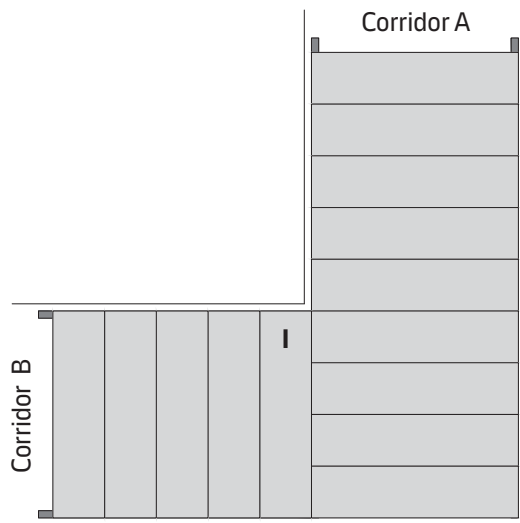

Corridor A runs to the end, corridor B connects to it and forms a transition.

METAL F-H 600 SWING

Wall bracket + G-Profile secondary grid

Exposed grid corridor solution for indoor applications

General information

- Exposed hook-on grid system for corridors
- Wall bracket (black coated) and G-Profile in RAL 9010 made of galvanised steel
- Typical ceiling weight 9.1 - 10.6 kg/m² (indicative value for unperforated panels, without additional load)
- With variable shadow gap along the walls
- Panels are easily installed and fully demountable
- Panels with swing down function
- Suitable for large panel sizes and chilled ceilings

Isometric view

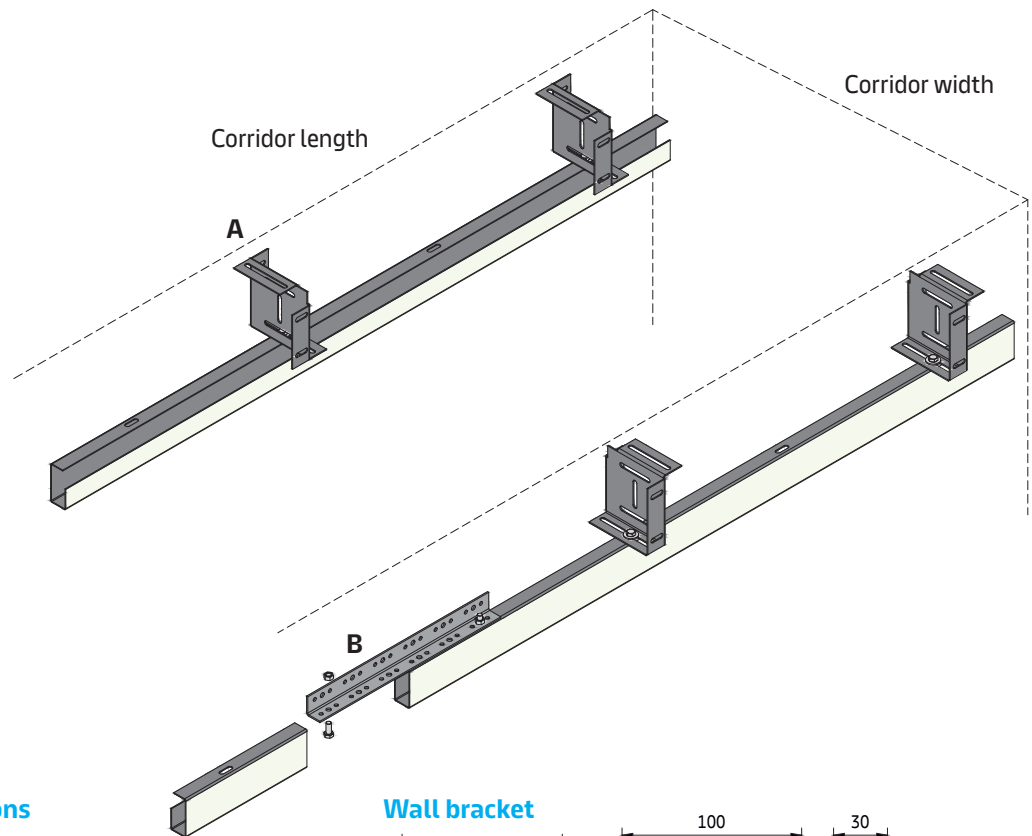

Vario Design layout options

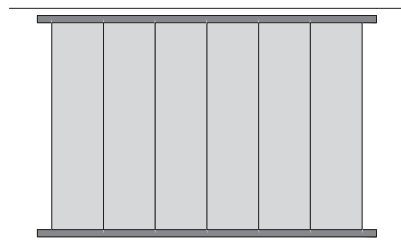

Wall bracket

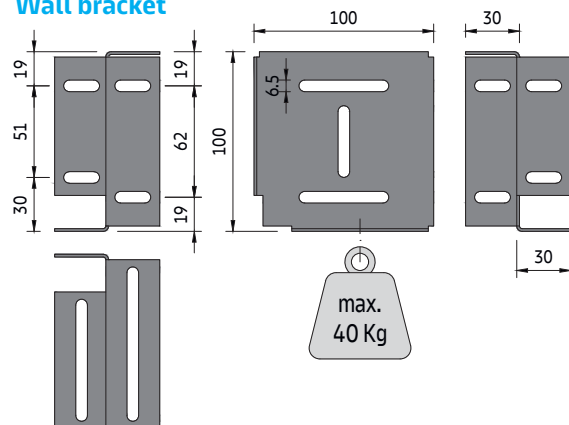

Section C

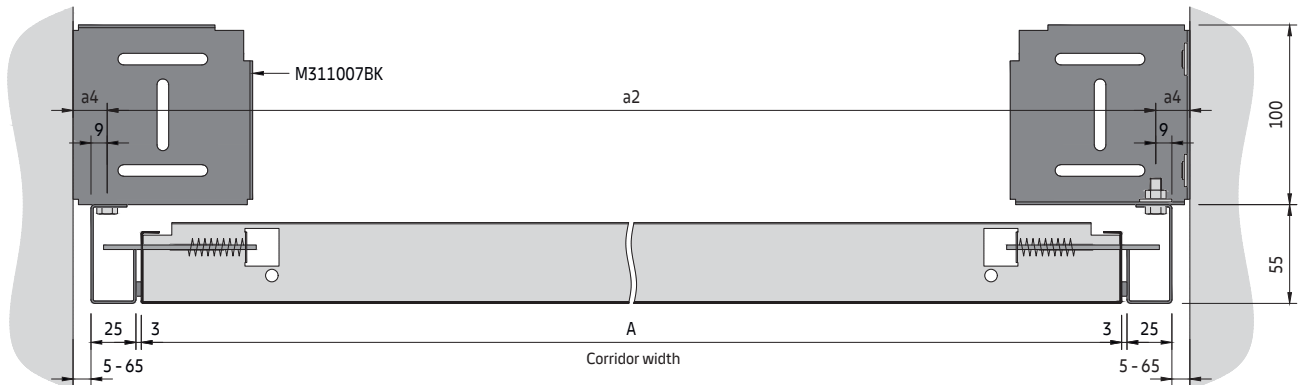

Section D

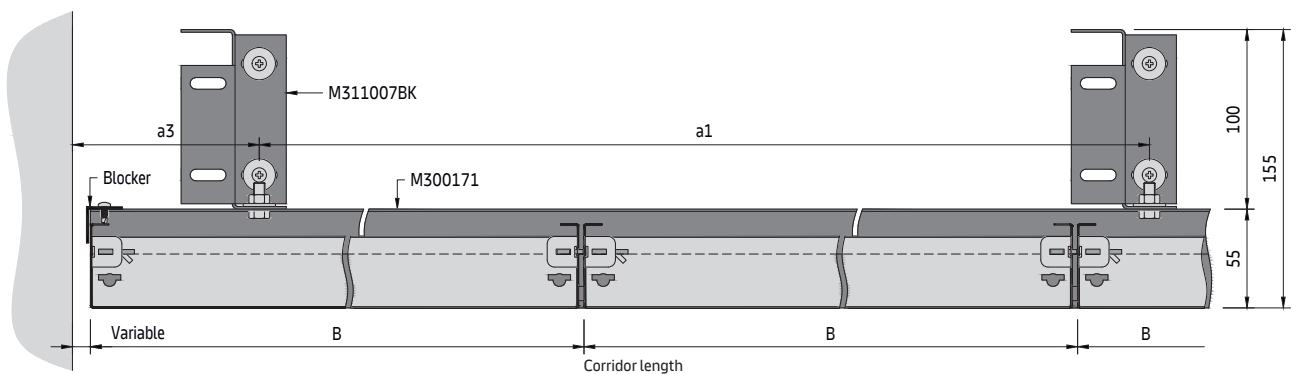

Panels supplied as standard with a 3 mm gasket on one long and both short sides to improve the visual appearance. An option without gasket is not possible. Be careful with the last panel. Make sure that it cannot fall off the G-Profile. Use a blocker, in the shape of an angle.

Grid components

Standard components

- M311007BK Wall bracket
- M300171 G-Profile RAL 9010
- M311103 Hexagonal nut M6
- M311105 Washer
- M311303 Hexagonal bolt M6 x 16 mm
- M311051 Primary angle 3000 x 27 x 22 mm

Optional components

- M311099 Threaded rod M6 x 1000 mm
- M215110 RA 1 perimeter trim 4000 x 20 x 20 mm RAL 9010
- M311051 Black gasket 8x3 mm (spare roll)

G-Profile secondary grid

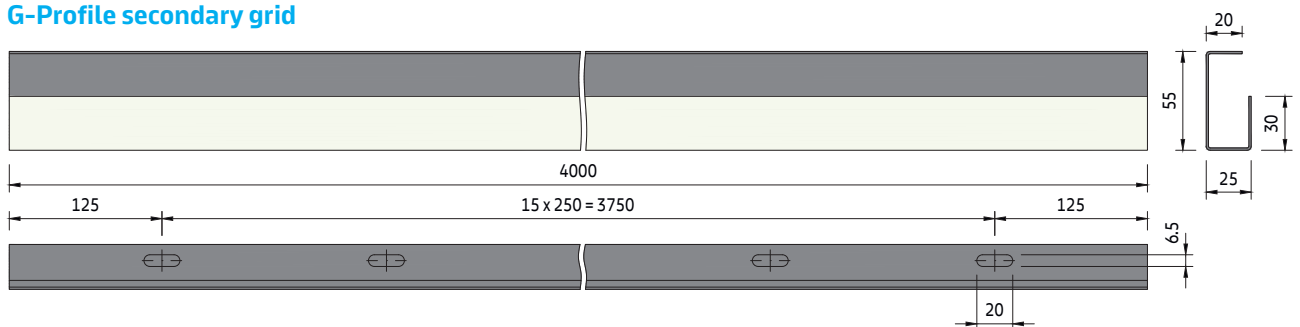

Spacing

a2 [mm]	System without additional load a1 [mm]	System with additional load +4 kg/m ² a1 [mm]
1000	1750	1500
1050	1750	1500
1100	1750	1500
1150	1750	1500
1200	1500	1500
1250	1500	1250
1300	1500	1250
1350	1500	1250
1400	1500	1250
1450	1250	1250
1500	1250	1250
1550	1250	1250
1600	1250	1250
1650	1250	1000
1700	1250	1000
1750	1250	1000
1800	1250	1000
1850	1000	1000
1900	1000	1000
1950	1000	1000
2000	1000	1000
2050	1000	1000
2100	1000	1000
2150	1000	1000
2200	1000	1000
2250	1000	1000
2300	1000	750
2350	1000	750
2400	1000	750
2450	1000	750
2500	750	750
2600	750	750
2700	750	750
2800	750	750
2900	750	750
3000	750	750
3100	750	750
3200	750	750
3300	750	750

Parameters

- a1 Distance of wall brackets
- a2 Distance between G-Profile fixing points = A - 38 mm
- a3 Distance from wall = max. 200 mm
- a4 Variable distance from wall to G-Profile fixing point
- M Module size = panel length / panel width
- A Panel length = min. 600 / max. 3300 mm
- B Panel width = min. 247 / max. 1350 mm

Typical grid layout

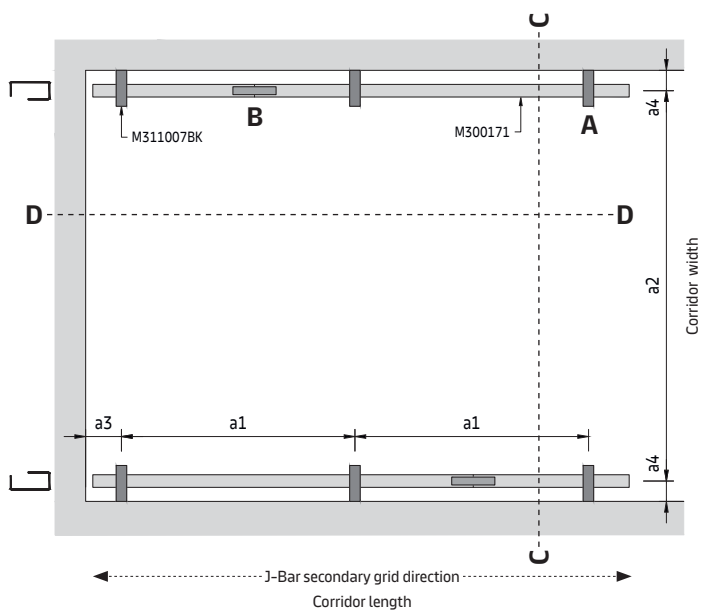

To determine suspension layout

The panel length (A) of the requested ceiling -38 mm is equal to the distance between the G-Profile centres (a2).

On the appropriate spacing table, read down the column headed (a2) to the required panel length then read across to determine the wall bracket spacing (a1).

The shown values are maximum allowed distances and can be reduced but not exceeded.

Detail A

G-Profile installation

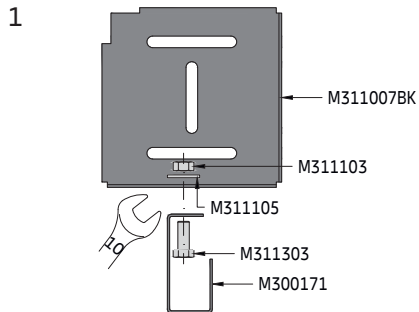

Fix the G-Profile with fasteners below the wall bracket.

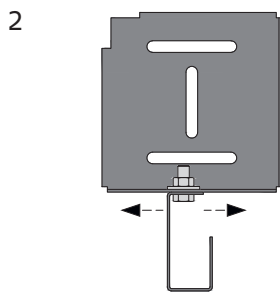

The G-Profile is now locked in position.

Detail B

Splice connection



The ends of the G-Profiles should be butt together without a gap.

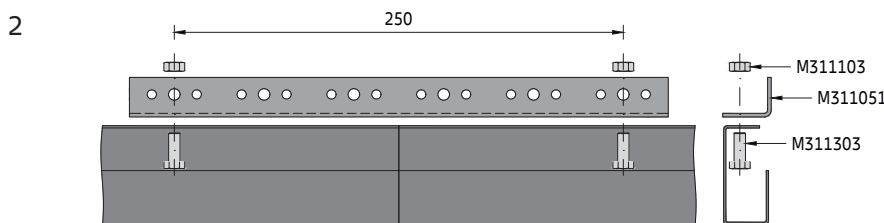

Use a primary angle and cut it to a length of ≈ 300 mm

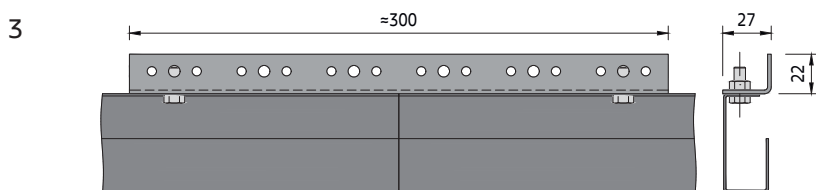

Use the bolts to screw it together. Stagger the joints.

Detail E

Panel insertion

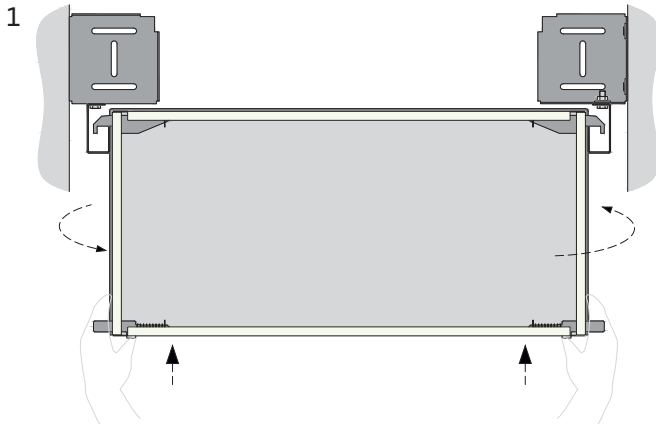

Unlike panels without a swing-down function, these are hung vertically in the G-Profiles. These have to be turned in slightly in order to be able to be hung on the G-Profiles.

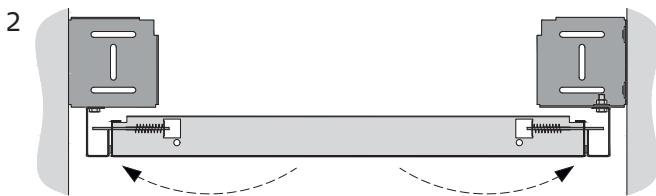

The panels can then be swung up. The brackets are carefully pushed inwards until they pass the G-Profile. Be careful that the brackets do not scratch the G-Profile.

Panel extraction

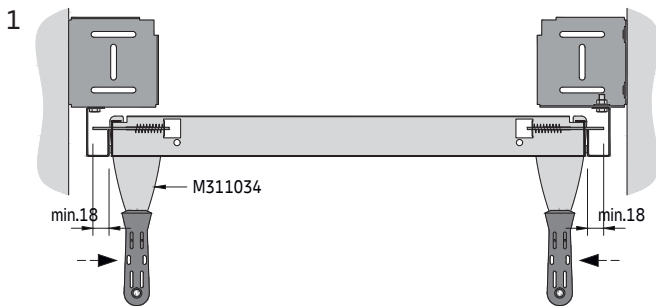

Use the extraction tool to release the brackets on the panel. Swing the panel down carefully. The panels swing-down over the long side. Insert the extraction tool carefully to avoid damaging the gasket.

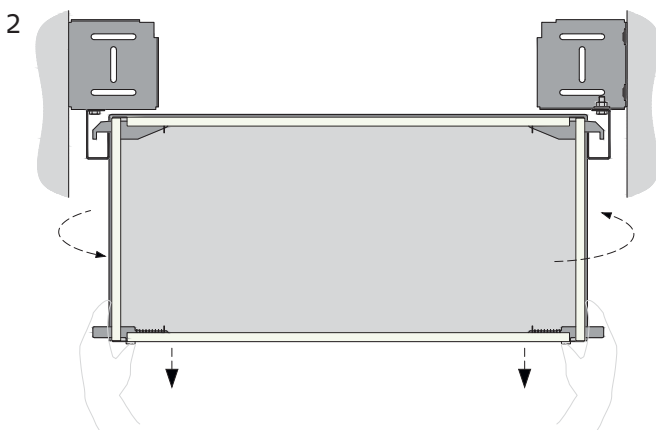

Move the panel aside to allow access to the plenum. Up to three adjacent panels can be suspended at once. Do not exceed this number, otherwise the weight would be too high on the G-Profile.

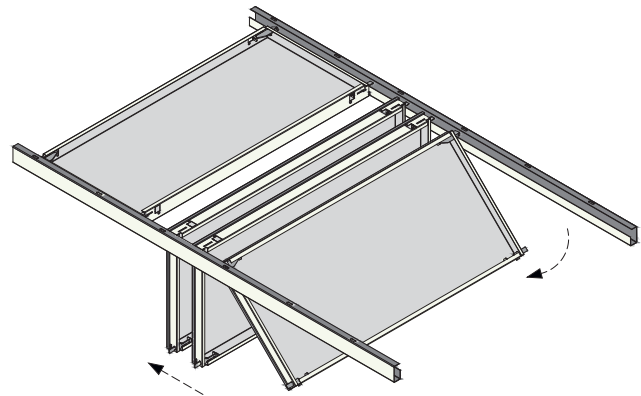

METAL F-H 600 SWING

D02.403

Detail F

Optional perimeter trim for cut panels

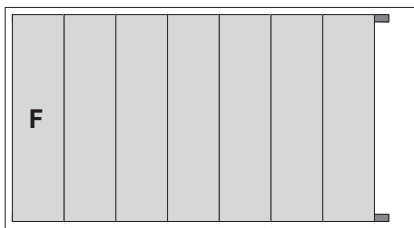
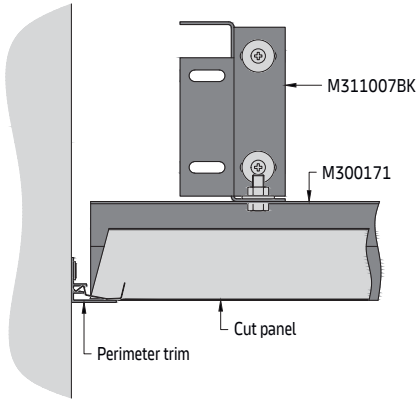

The last panel at the end of the corridor can be made to measure. A cost-effective alternative is to use a perimeter trim. This allows panels to be cut to size on site. As a result, the last panel can no longer be swung down. See separate document for perimeter trim options.

Detail G

Optional perimeter trim for shadow gap

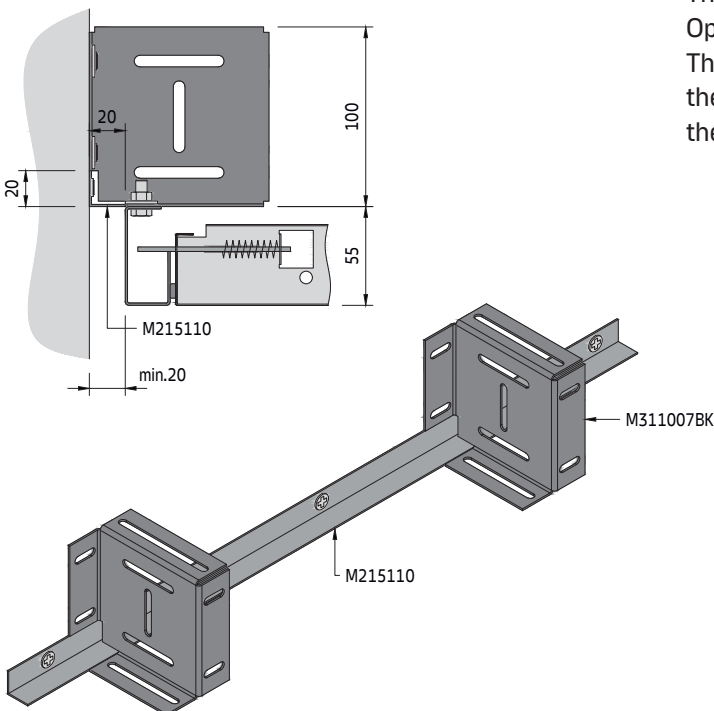

The shadow gap remains open in the standard version. Optionally, this can be covered with a perimeter trim. The perimeter trim is attached at the correct height so that the wall brackets can be placed on it and then attached to the wall.

Detail H

Suspension option by double threaded rod

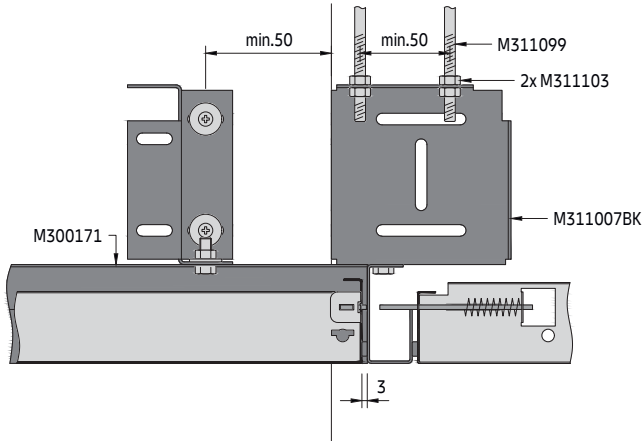

Suspension option by threaded rod with angle bracing

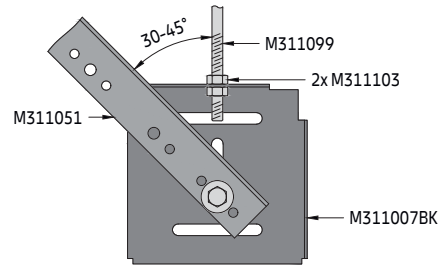

In these situations, the wall bracket can be suspended either with two threaded rods or one threaded rod and fixed by an angle bracing.

T-junction

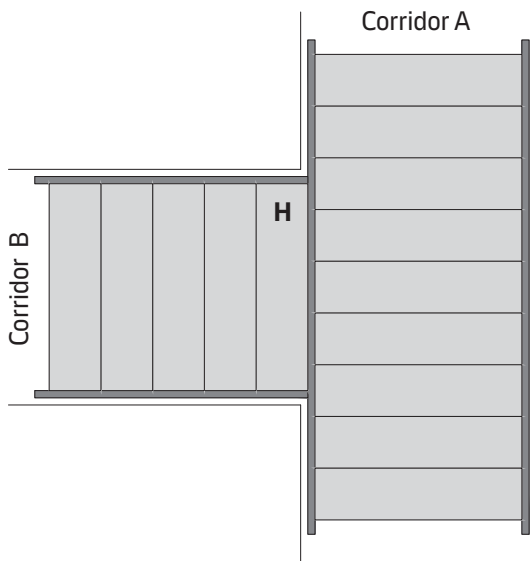

Corridor A runs through, corridor B connects to it and forms a T-junction.

Corner

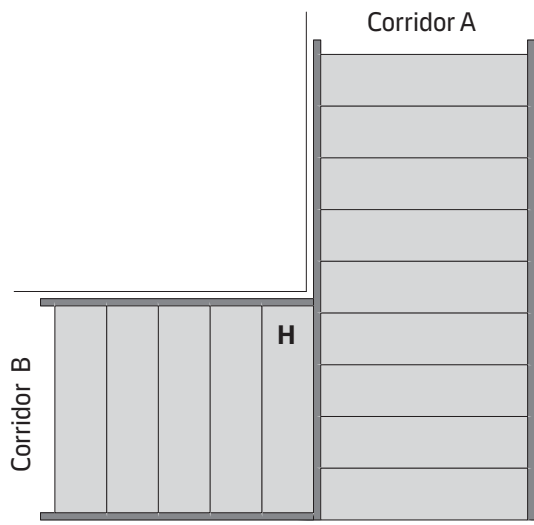

Corridor A runs to the end, corridor B connects to it and forms a transition.

METAL F-H 600 SWING

D02.403

Material required per m² (no waste included)**System without additional load [pcs/m²]**

Components		a2 [mm]	1200	1600	1800	2000	2400	2800	3000	3300
M300171	G-Profile RAL 9010		0.42	0.31	0.28	0.25	0.21	0.18	0.17	0.15
M311007BK	Wall bracket		1.11	1.00	0.89	1.00	0.83	0.95	0.89	0.81
M311051	Primary angle 3000 x 27 x 22 mm		0.03	0.02	0.02	0.02	0.02	0.01	0.01	0.01
M311103	Hexagonal nut M6		1.53	1.31	1.17	1.25	1.04	1.13	1.06	0.96
M311105	Washer		1.11	1.00	0.89	1.00	0.83	0.95	0.89	0.81
M311303	Hexagonal bolt M6 x 16 mm		1.53	1.31	1.17	1.25	1.04	1.13	1.06	0.96

The shown quantities are theoretical and based on an ideal layout, without considering the actual room layout. The ideal layout is based on a calculation 100 m². This calculation does not allow any damage, spare nor wastage. The final quantities and type of suspension have to be checked before ordering. Soffit and wall fixings by others. Not including optional items.





Floating Ceilings – Canopies

METAL Sonic Element

Hanging wire

Single canopy solution for indoor applications

General information

- Hanging wire for single suspension in open spaces
- Optional acoustic pad and rear cover (factory fixed by pop-rivets)
- Typical canopy weight 4.3 – 26.0 kg/m² (indicative value for unperforated canopies, without additional load)
- Canopies are easily installed and fully demountable
- Acoustic & design elements

Isometric view

Option with rear cover shown

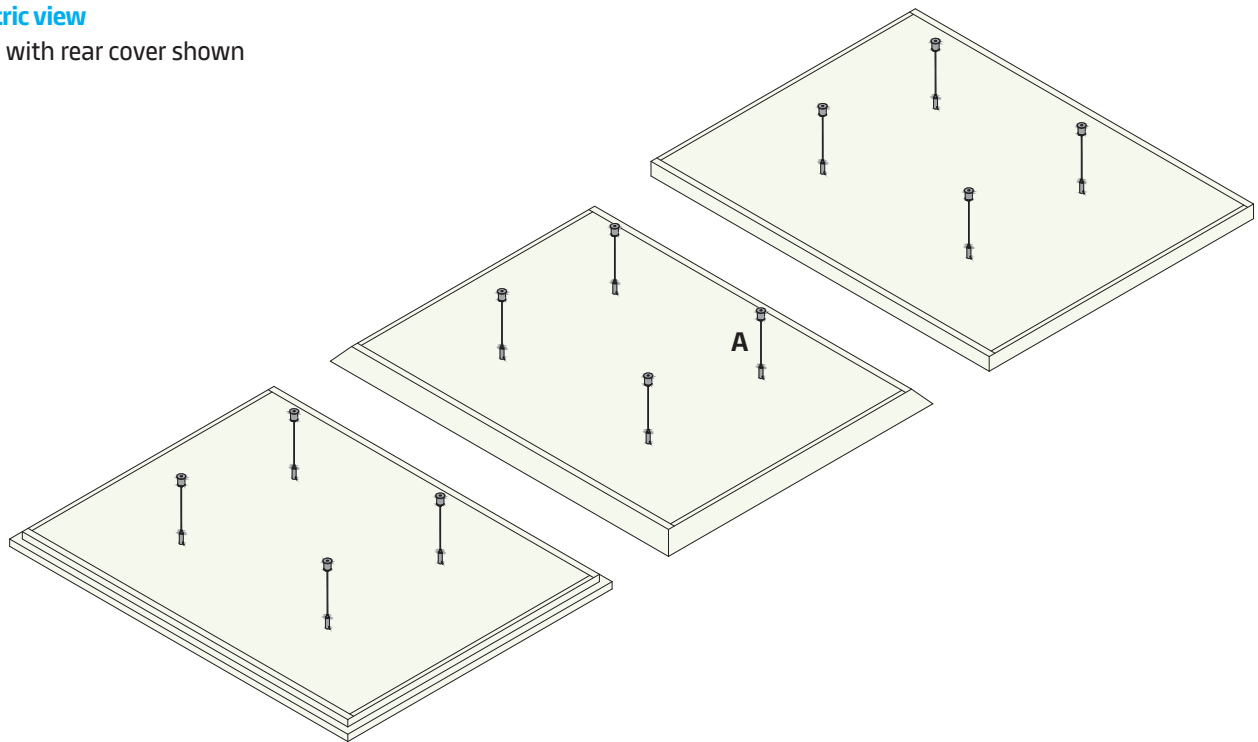

Important information:

The hanging wires are supplied in a length of 4000 mm. If the room height is lower than this, the suspension points can be attached to the back of the canopy while it is on the ground. Please make sure that the visible side is protected during the assembly and cannot be scratched. In general, be careful when handling and transporting these large and heavy items. The canopy was primarily designed for horizontal installation. Slight angles are possible, but the limit must be checked beforehand. This installation depends on the dimensions and configuration of the canopy. Since these are single canopies, a lateral distance of at least 200 mm is recommended for installation. On request, the canopy can be supplied with a rear cover. This prevents dust and dirt from entering the canopy. This makes cleaning easier.

Vario Design layout options:

Rectangular

Square

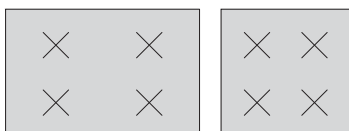

Canopy edge detail options:

90° edge

50° edge

20x20 mm edge

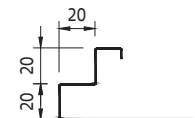
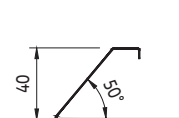
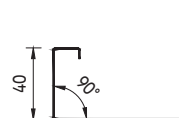

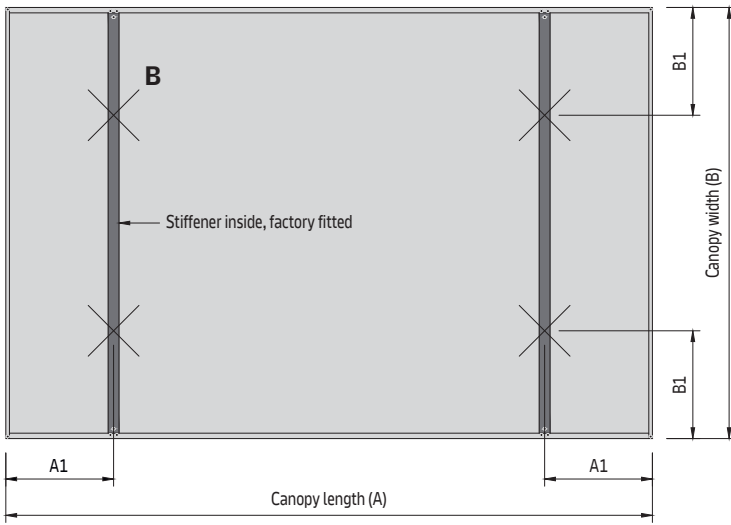

View from rear side

Parameters

- A Canopy length = min. 600 / max. 1800 mm
- A1 (A = 600 - 899) = 100 - 150 mm
(A = 900 - 1800) = 150 - 300 mm
- B Canopy width = min. 600 / max. 1200 mm
- B1 (A = 600 - 899) = 100 - 150 mm
(A = 900 - 1200) = 150 - 300 mm

Detail A

CS5550 Wire hanging kit installation

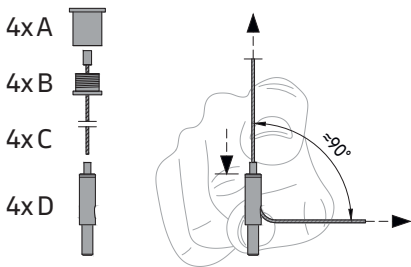

- 1 Place an M6 threaded bolt on the ceiling soffit by others.
- 2 Take the hanging wire (C) and loop it through the top of the gripper anchor cap (B).
- 3 Screw the gripper anchor cap (B) onto the structure gripper anchor (A).
- 4 Screw the height adjuster (D) into the stiffener on the back of the canopy.
- 5 Guide the hanging wire (C) into the height adjuster (D). Pull the wire through the height adjuster, in an angle of $\approx 90^\circ$. Do not pull the wire upwards, otherwise it may be damaged.
- 6 Then either roll up the wire and deposit it on the canopy or cut it away. After cutting it away, it can no longer be adjusted in height. Repeat this for all four suspension points.

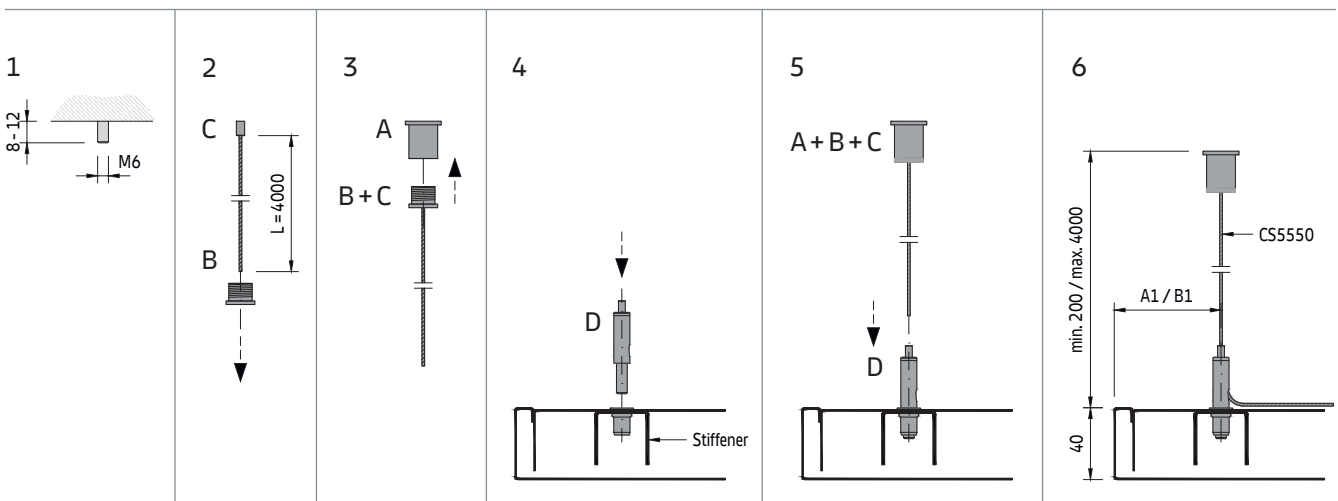

METAL Sky Element Clip

U-Profile primary grid + DP12 A-Bar secondary grid
Concealed grid solution for indoor applications

General information

- Concealed clip-in grid system for a single row of panels in open spaces
- For perpendicular installation on U-Profile primary grid
- DP12 A-Bar made of galvanised steel
- Typical ceiling weight 7.0 - 8.0 kg/m² (indicative value for unperforated panels, without additional load)
- Panels are easily installed and fully demountable
- Optional swing-down function for standard panels
- DP12 A-Bar made of galvanised steel

Isometric view

Select the suspension option E1 - E4.

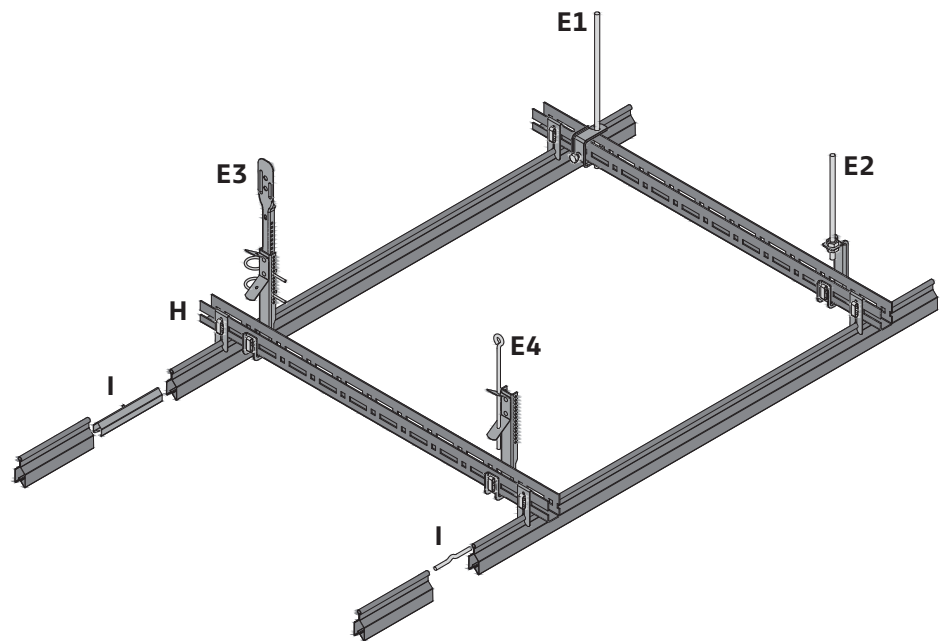

Vario Design layout options

Single

Double

Multiple

Single panel

End panel
End panel

End panel
Standard panel
Standard panel
Standard panel
Standard panel
End panel

METAL Sky Element Clip
E02.002

Section F

Example with suspension option E1

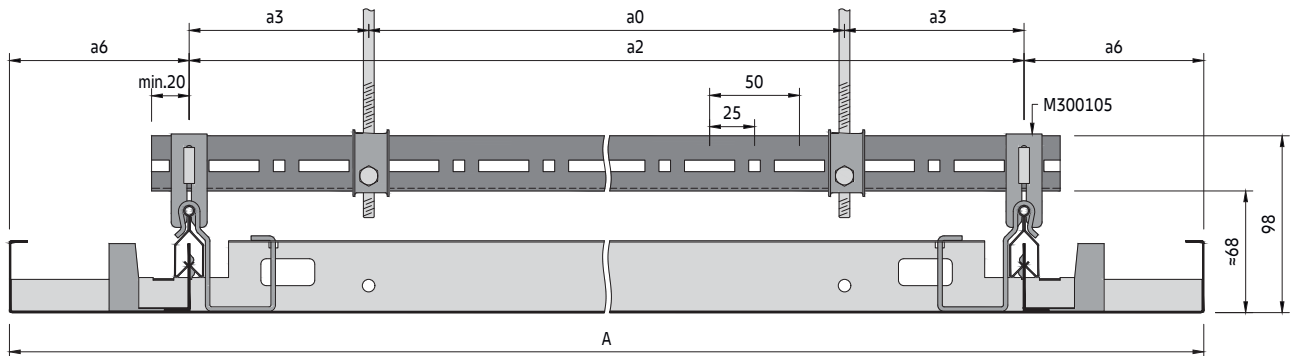

Section G

Example with suspension option E1

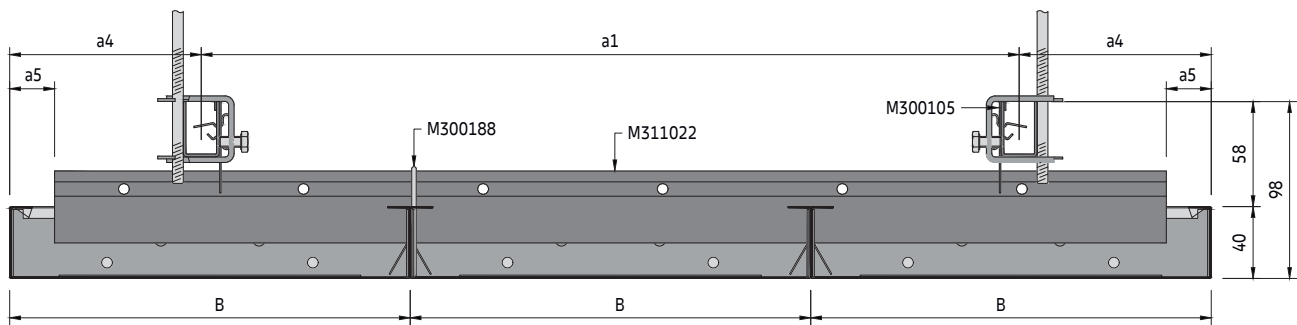

Secondary grid components

Standard components

- M311022 DP12 A-Bar
- M300138 Connection pin for DP12 A-Bar
- M300105 Hanger for DP12 A-Bar
- M300120 Plug-in clip for U-Profile

Optional components

- M300106 Security clip
- M311028 Extraction tool
- M311023 Splice connector for DP12 A-Bar
- M311191 Self-drilling screw 3.5 x 9.5 mm
- M300188 Swing down clip for ACCESS function (DP12 A-Bar)

See U-Profile primary grid for primary grid components.

DP12 A-Bar secondary grid

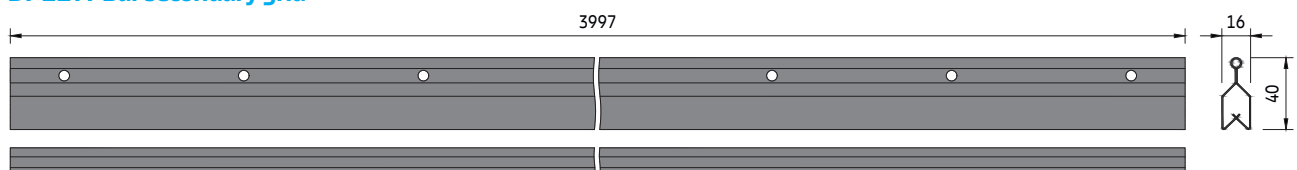

METAL Sky Element Clip
E02.002

Spacing

a2 [mm]	System without additional load		System with additional load +4 kg/m ²	
	a0 [mm]	a1 [mm]	a0 [mm]	a1 [mm]
800	700	1500	700	1400
900	800	1500	800	1400
1000	900	1500	900	1400
1100	1000	1500	1000	1400
1200	1100	1500	1100	1400
1300	1200	1500	1200	1400
1400	1300	1100	1300	750
1500	1400	1100	1400	750
1600	1500	1100	1500	750
1700	1600	1100	1600	750
1800	1700	1100	1700	750
1900	1800	1100	1800	750
2000	1900	1100	1900	750
2100	1000	1100	1000	750
2200	1050	1100	1050	750
2300	1100	1100	1100	750

To determine suspension layout

The panel length (A) of the requested ceiling is equal to the distance between the DP12 A-Bar centres (a2) - 2x (a6).

On the appropriate spacing table, read down the column headed (a2) to the required module length then read across to determine the suspension point spacing (a0) and U-Profile spacing (a1).

The shown values are maximum allowed distances and can be reduced but not exceeded.

Parameters

- a0 Distance between U-Profile suspension points = max. 1900 mm
- a1 Max. distance between U-Profiles
- a2 Distance between DP12 A-Bars = panel length (A) - 2x a6
- a3 Distance from U-Profile suspension point to hanger = max. 100 mm
- a4 Distance from end panel edge to U-Profile = min. 150 / max. 350 mm
- a5 Distance from end panel edge to DP12 A-Bar = min. 15 / max. 30 mm
- a6 Distance from panel edge to hanger = 100 mm
- A Panel length = min. 600 / max. 2500 mm
- B Panel width = min. 250 / max. 600 mm

Typical grid layout

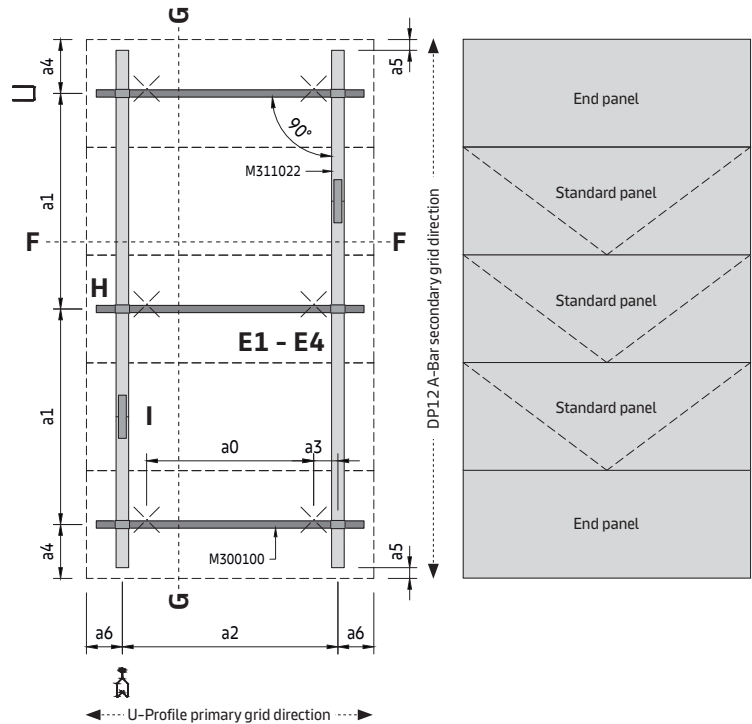

METAL Sky Element Clip
E02.002

Detail H

Hanger installation

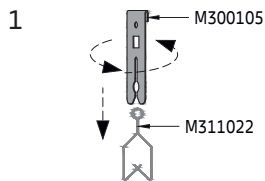

The hanger for DP12 A-Bar is made of spring steel and is therefore elastic. It is twisted on the DP12 A-Bar from above. Then it can be slid to the correct position.

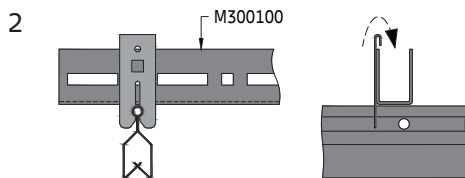

Hang the DP12 A-Bar with the hangers under the U-Profile.

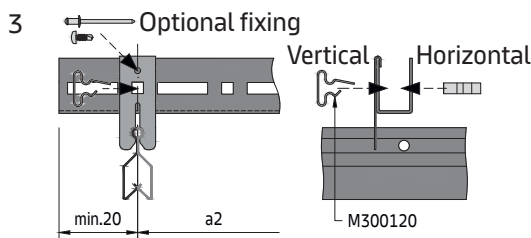

Fix hanger with plug-in clips at the specified module spacing (inserted vertically or horizontally). If the panel size does not fit with the modulation of the U-Profile in 25 mm increments, the plug-in clip needs to be inserted into a long hole. The hanger position can be fixed by using a pop-rivet or self-drilling screw.

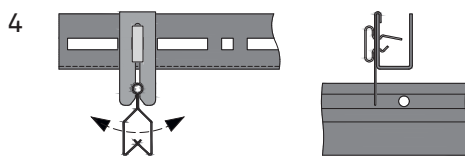

The DP12 A-Bar is now locked in position. Due to the round head of the DP12 A-Bar, it can swing. This is important because it allows any tolerances to be compensated. Otherwise the panels can no longer be inserted after a certain point.

Detail I

Splice connection

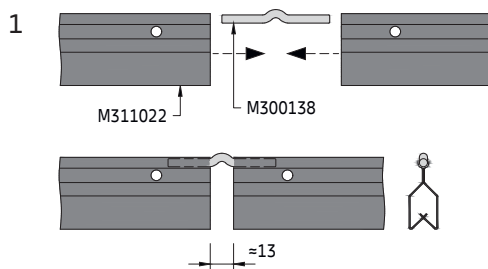

Insert the connection pin at the ends of the DP12 A-Bars and connect them. There is a gap between the DP12 A-Bars. The DP12 A-Bars must be aligned so that the joint is not in the same place as the pips on the panels.

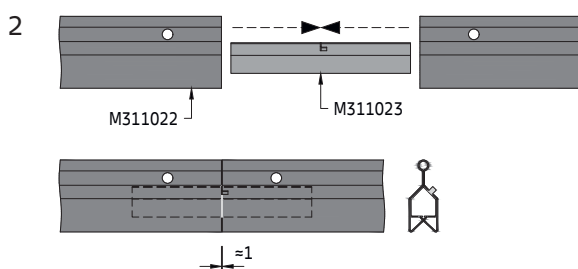

Optionally, the splice connector for DP12 A-Bar can be used. This is inserted at the ends of the DP12 A-Bars and an almost seamless connection is created.

METAL Sky Element Clip
E02.002

Detail J

Panel insertion

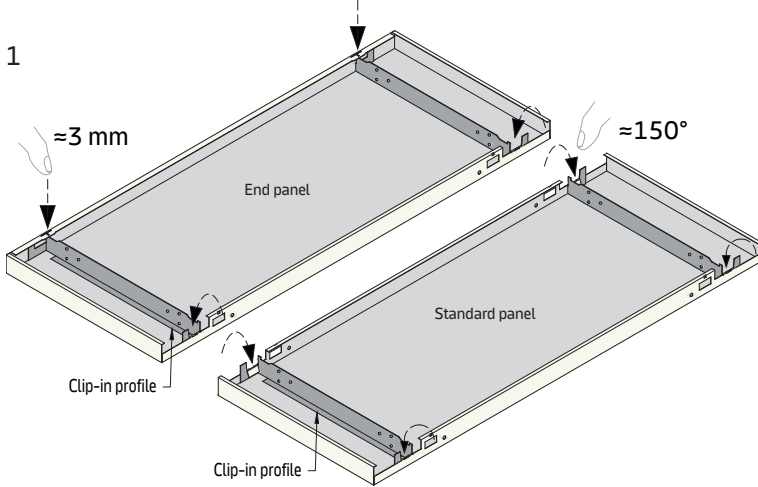

The clip-in profiles are supplied loose and must be attached to the panels before insertion. The standard panels have two tabs on each long side, which are pressed inwards by $\approx 150^\circ$ with your finger. One long side of the end panel is visible. Therefore, the upper edge is carefully pressed down ≈ 3 mm until the profile sticks out a little at the top. This fixes the profiles.

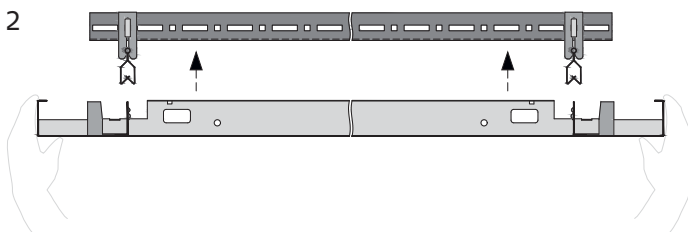

Take the panel and carefully insert it into the DP12 A-Bars from below. Be careful with the panels. Always press along the edges with the pips and never on the transverse sides, otherwise the panel may be damaged. The panels can only be laid in the same direction.

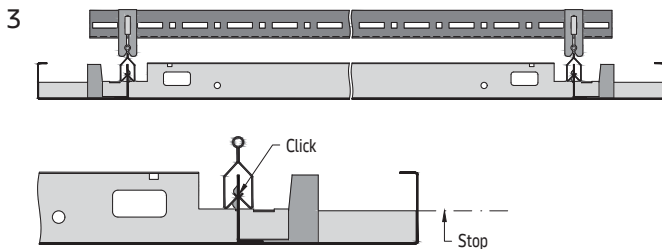

The panels are correctly inserted when all four corners are flush with the neighbouring panels. The panels are designed to match the DP12 A-Bar. If third party profiles are used there is a high probability the tiles will not be correctly inserted.

Panel extraction

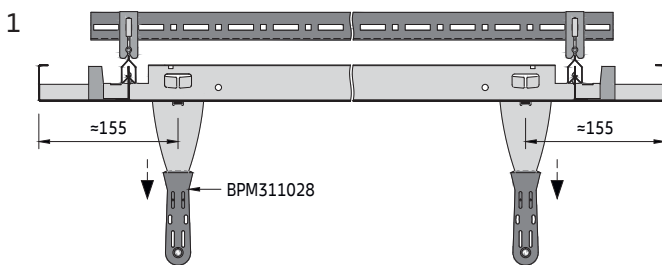

The panels are designed in such a way that the extraction tool can only be inserted in the designated places so that it clicks into place. There is a rectangular cut-out on the panels. It is therefore important that the appropriate extraction tool is used. This prevents damage to the panels. Insert the extraction tool on one side first and pull down with a gentle tug, followed by the opposite side.

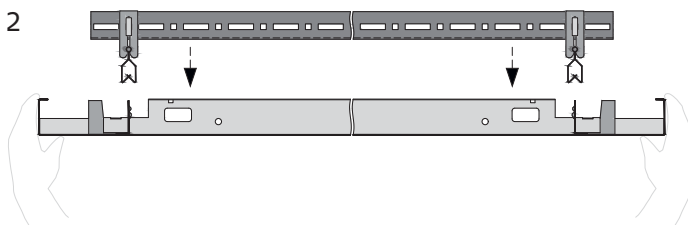

Remove it downwards and store the panel in a safe place so that it cannot be damaged.

METAL Sky Element Clip
E02.002

Detail K
Panel locking

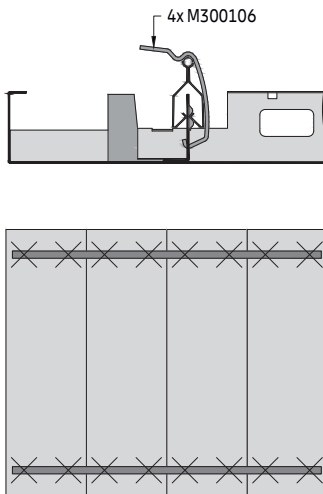

There are two holes in each of the clip-in profiles with which the panels can be fixed. First hook the security clip into the panel and then slip the upper end over the DP12 A-Bar. Four security clips are required per panel.

Either individual panels or the entire ceiling can be secured. The panels are inserted and secured immediately.

Detail L
Optional swing-down funktion

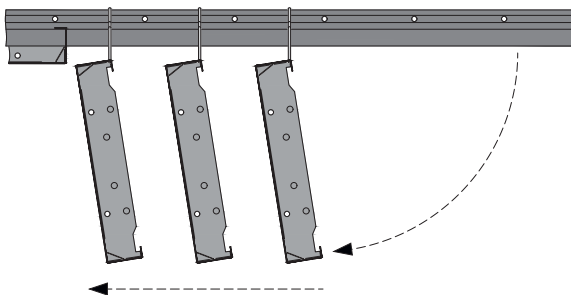

The panels are hinged-down from the long side. Up to three adjacent panels can be suspended at once. Do not exceed this number, otherwise the weight would be too high on the DP12 A-Bar. The panels are installed in the same direction (HOOK detail).

The panels are provided with two small holes, which are used to insert the ACCESS swing-down clip. Once the clips are inserted, hook the panel on the DP12 A-Bar. Two clips per panel are needed.

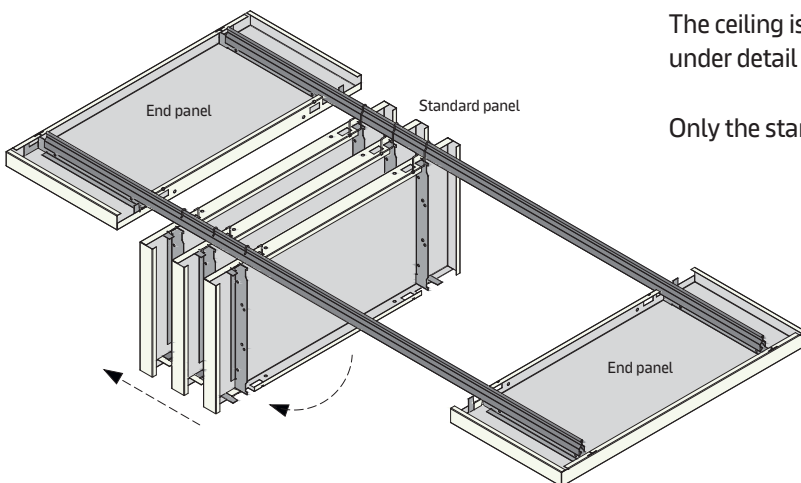

The ceiling is accessed with the extraction tool, as shown under detail D.

Only the standard panels have a swing-down funktion.

METAL Sky Element HOOK

U-Profile cross-connected grid
Concealed grid solution for indoor applications

General information

- Concealed hook-on grid system for a single row of panels in open spaces
- For perpendicular installation on U-Profile primary grid
- U-Profile made of galvanised steel
- Typical ceiling weight 7.0 - 8.0 kg/m² (indicative value for unperforated panels, without additional load)
- Panels are easily installed and fully demountable
- Optional panel height of 65 mm for additional acoustic infills or chilled ceilings

Isometric view

Select the suspension option F1 - F3.

Important information

This system was developed for a single row of panels. In order for the components to be used, a panel length and width in increments of 25 mm must be maintained. For smaller module sizes, the U-Profile primary grid and the lateral U-Profiles can be assembled on the ground and then hung on the suspension points as a frame. Otherwise, the U-Profile primary grid is installed first and then the lateral U-Profiles attached to it.

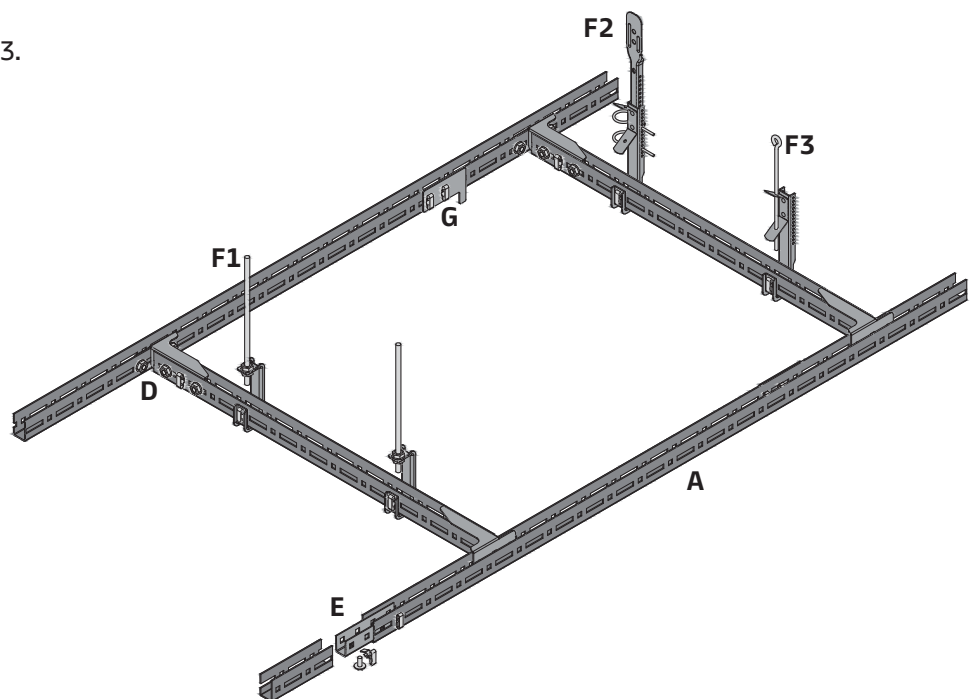

Vario Design layout options

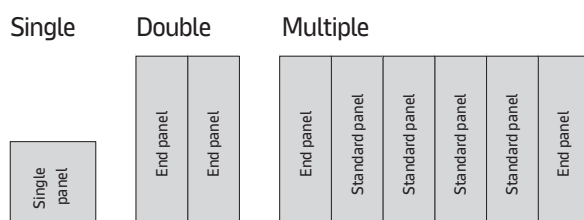

Detail A

U-Profile modulation

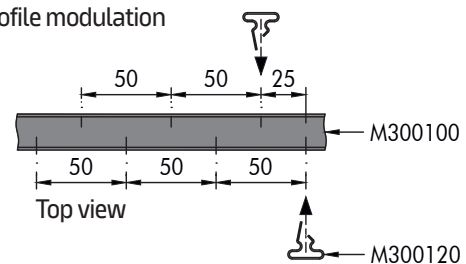

The U-Profile primary grid is a modular system based on a spacing of 50 mm. The holes on the lateral sides are offset from each other by 25 mm. This means that distances of 25 mm can be achieved.

METAL Sky Element HOOK
E02.003

Section B

Example with suspension option F1

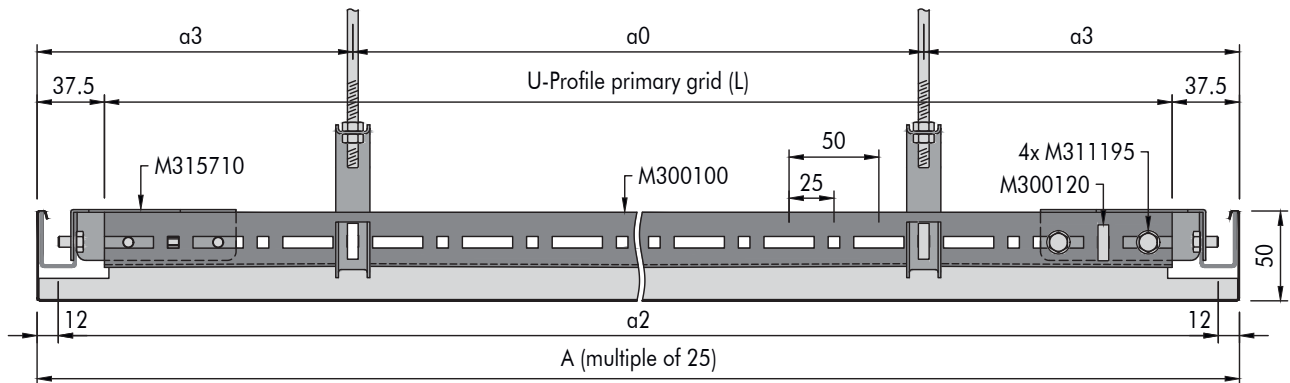

Section C

Example with suspension option F1

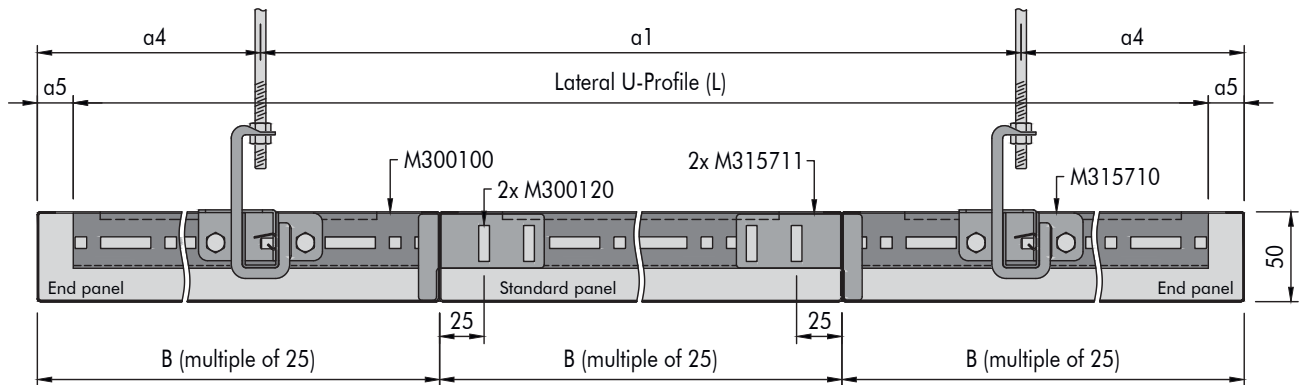

Grid components

Standard components

- M300100 U-Profile
- M300119 Splice connector for U-Profile
- M315710 Cross-connector for U-Profile
- M300120 Plug-in clip for U-Profile
- M311195 Thread cutting screw M6 x 10 mm
- M315711 Security bracket 50 mm

Suspension option F1

- M300366 Hanger for U-Profile
- M311103 Hexagonal bolt M6
- M300120 Plug-in clip for U-Profile
- M311315 Hexagonal extension nut M6 x 30 mm (optional)
- M311061 Suspension element (optional)

Suspension option F2

- M300166 Combi-Nonius hanger for U-Profile
- - Nonius top part (various lengths)
- M300036 Nonius locking pin
- M300120 Plug-in clip for U-Profile

Suspension option F3

- M300166 Combi-Nonius hanger for U-Profile
- - Eye wire (various lengths)
- M300120 Plug-in clip for U-Profile

Optional components

- M315712 Security bracket 65 mm

METAL Sky Element HOOK E02.003

U-Profile grid

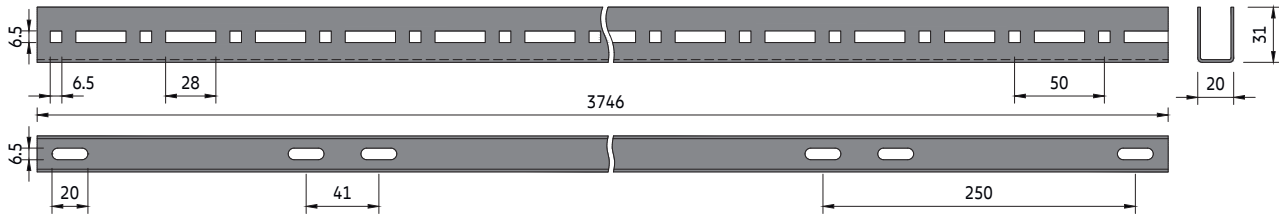

Spacing

a2 [mm]	System without additional load		System with additional load +4 kg/m ²	
	a0 [mm]	a1 [mm]	a0 [mm]	a1 [mm]
800	500	1400	500	1300
900	400	1400	400	1300
1000	700	1400	700	1300
1100	800	1400	800	1300
1200	900	1400	900	1300
1300	1000	1400	1000	1300
1400	1100	1400	1100	1300
1500	1200	1400	1200	1300
1600	1300	1400	1300	1300
1700	1400	1400	1400	1300
1800	1500	1100	1500	1000
1900	1600	1100	1600	1000
2000	1700	1100	1700	1000
2100	1800	1100	1800	1000
2200	1900	1100	1900	1000
2300	1000	1100	1000	1000
2400	1050	1100	1050	1000
2500	1100	1100	1100	1000
2600	1150	1100	1150	1000
2700	1200	1100	1200	1000
2750	1225	1100	1225	1000

To determine suspension layout

The panel length (A) of the requested ceiling is equal to the distance between the lateral U-Profile centres (a2) - 24 mm.

On the appropriate spacing table, read down the column headed (a2) to the required module length then read across to determine the suspension point spacing (a0) U-Profile primary grid spacing (a1).

The shown values are maximum allowed distances and can be reduced but not exceeded.

Parameters

- a0 Distance between U-Profile suspension points = max. 1900 mm
- a1 Max. distance between U-Profiles
- a2 Distance between lateral U-Profiles = panel length (A) - 24 mm
- a3 Distance from panel edge to suspension point = min. 125 / max. 250 mm
- a4 Distance from end panel edge to U-Profile = min. 150 / max. 350 mm
- a5 Distance from end panel edge to lateral U-Profile end = max. 25 mm
- A Panel length = min. 600 / max. 2750 mm (in steps of 25 mm)
- B Panel width = min. 250 / max. 600 mm (in steps of 25 mm)

Typical grid layout

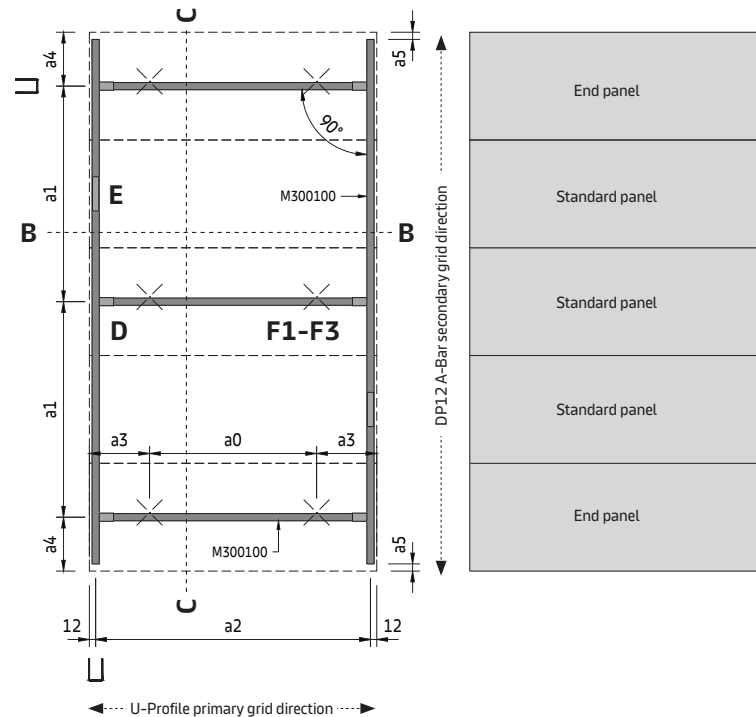

METAL Sky Element HOOK
E02.003

Detail D

Cross-connector installation

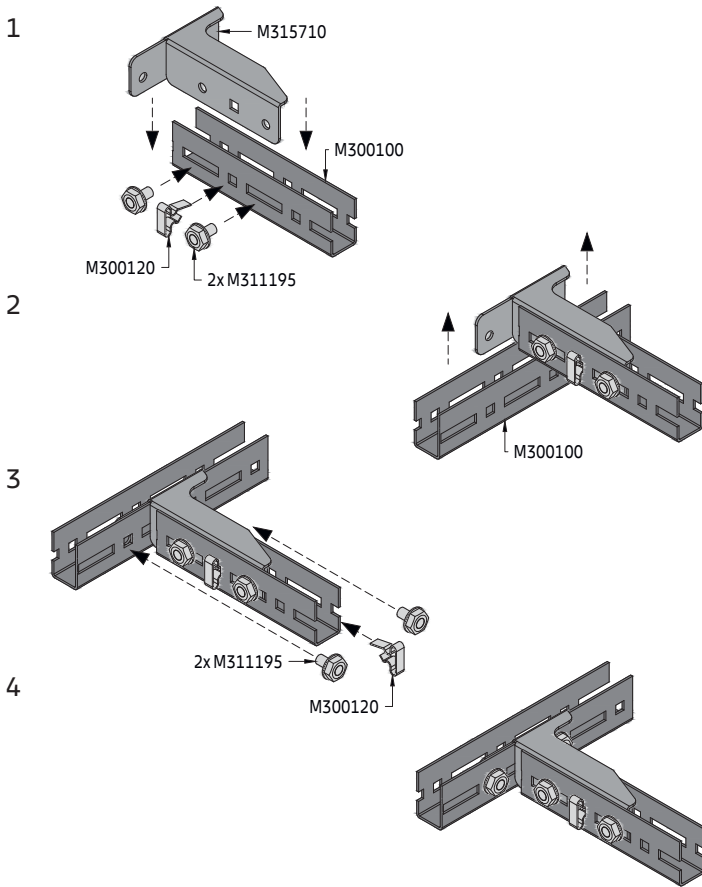

The cross-connector for U-Profile is fixed at both ends of the U-Profile primary grid. In order for this to work, a module dimension in 25 mm increments must be maintained. The plug-in clip can be used for positioning. The fixing itself is done with thread cutting screws. Standard M6 bolts cannot be used.

Align the lateral U-profile in the longitudinal direction and insert it so that the cross-connector is hooked.

Again use a plug-in clip and two thread cutting screws to fix the lateral U-Profile to the cross-connector.

The two profiles are now connected. Only a 90° connection is possible.

Detail E

Splice connection

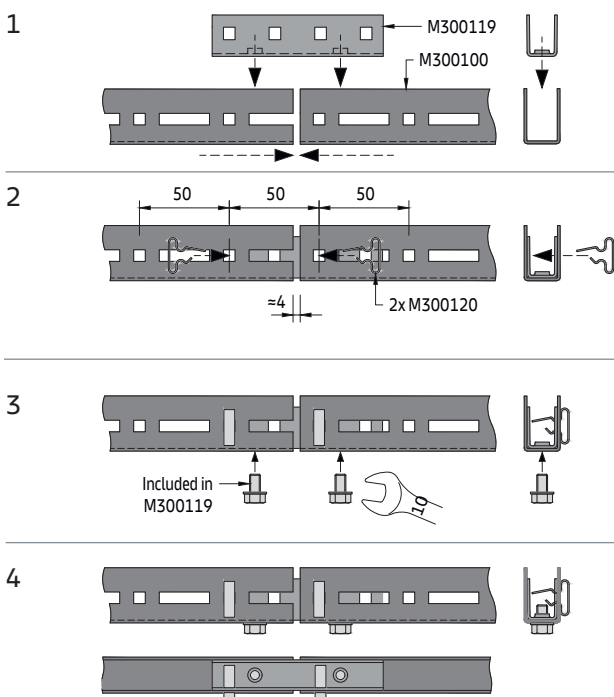

The splice connector for U-Profile comes with two bolts, which must first be removed. The splice connector is then placed between the two ends of the U-Profiles.

Fix the splice connector with two plug-in clips (large end upwards) at each end. This maintains the modular distance of 50 mm.

For a stable connection, the two supplied bolts are attached from below.

Since the U-Profile is a modular system, the ends must not touch. There is a distance of approx. 4 mm, depending on the length tolerance of the profile. Joints should be offset.

Detail F

Suspension options

Option F1

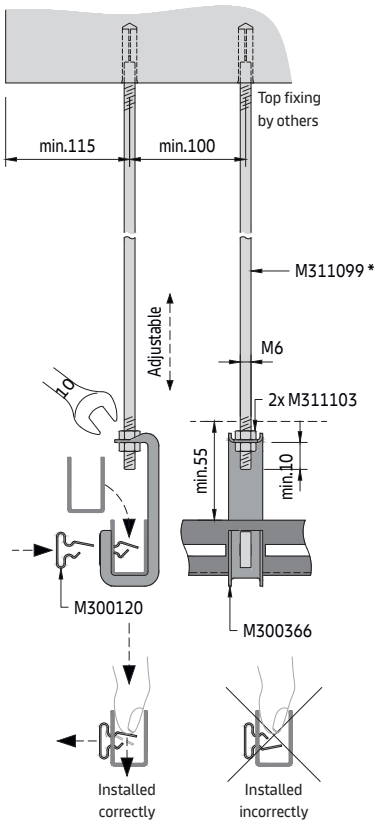

Suspension option **F1** is recommended as it is the least visible from below.

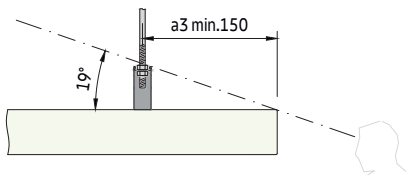

Option F2

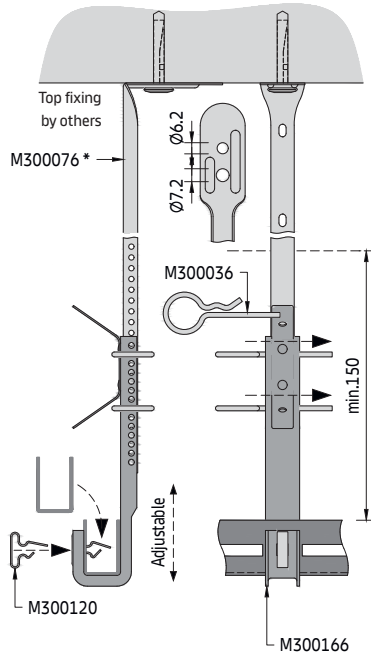

Please make sure that the elements have an overlap of at least 40 mm.

Option F3

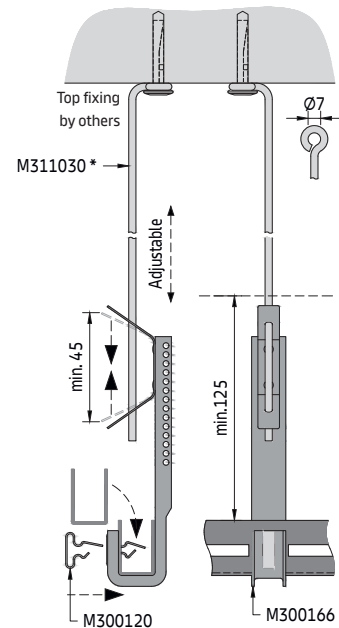

The clip should only be compressed as indicated to avoid possible damage.

Detail F4

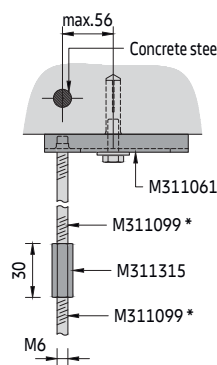

Optional top fixing and extension detail for suspension option F1

* Various lengths available

Detail G

Security bracket

Since the panels are only hooked-on, their position can shift, e.g. due to vibrations or maintenance work. To prevent this, the end panels are held in place with a security bracket. Two security brackets are required per end panel, which are each fixed with two plug-in clips.

The panels are fixed at the end of the installation. This requires a min. space from either the long or short side of the canopy.

X Space from the long side = min. 200 mm

Y Space from the short side = min. 100 mm

The security bracket can be easily removed at any time.

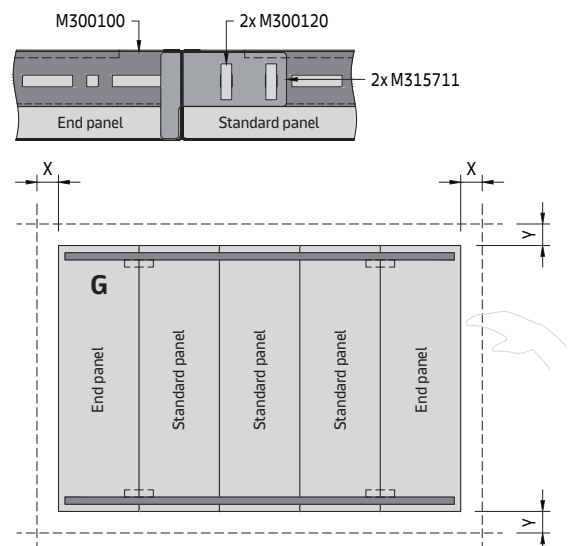

METAL Sky Element HOOK
E02.003

Detail H

Panel insertion

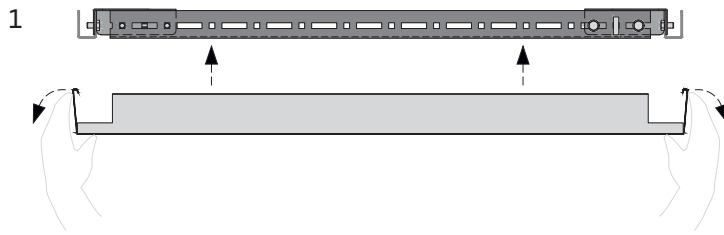

Take the panel and carefully pull the two short end HOOK details outwards a little. Due to the higher edge detail, it is elastic enough not to be damaged.



Hook the panel on both lateral U-Profiles. The short ends then return to their original vertical position.

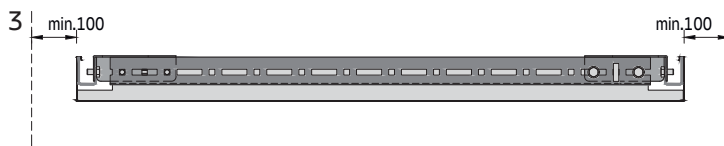

A lateral space of min. 100 mm is recommended in order to be able to hook-on the panels. Insert the panel holders to fix the position of the end panels (see detail G).

Panel extraction



If you want to extract an end panel, the panel holders must first be removed (see detail G). If it is a standard panel, then this is not necessary.

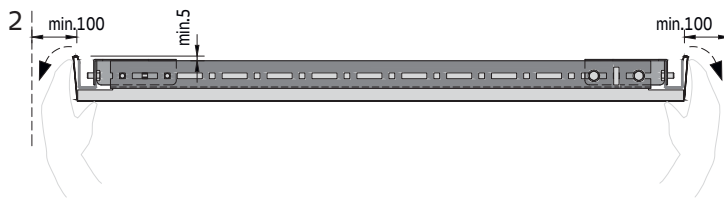

Lift the panel by at min. 5 mm and carefully pull the two short end HOOK details slightly outwards. Just enough so that the panel can be detached from the U-Profiles.

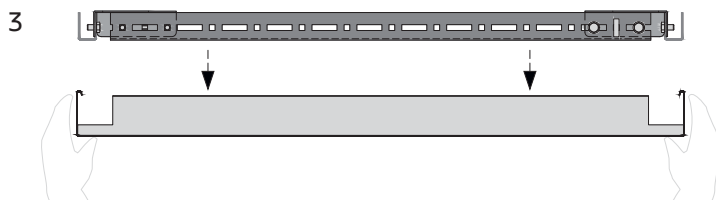

Remove it downwards and store the panel in a safe place so that it cannot be damaged.



METAL Baffle Element
E&Y, Warsaw, Poland
© Szymon Polański

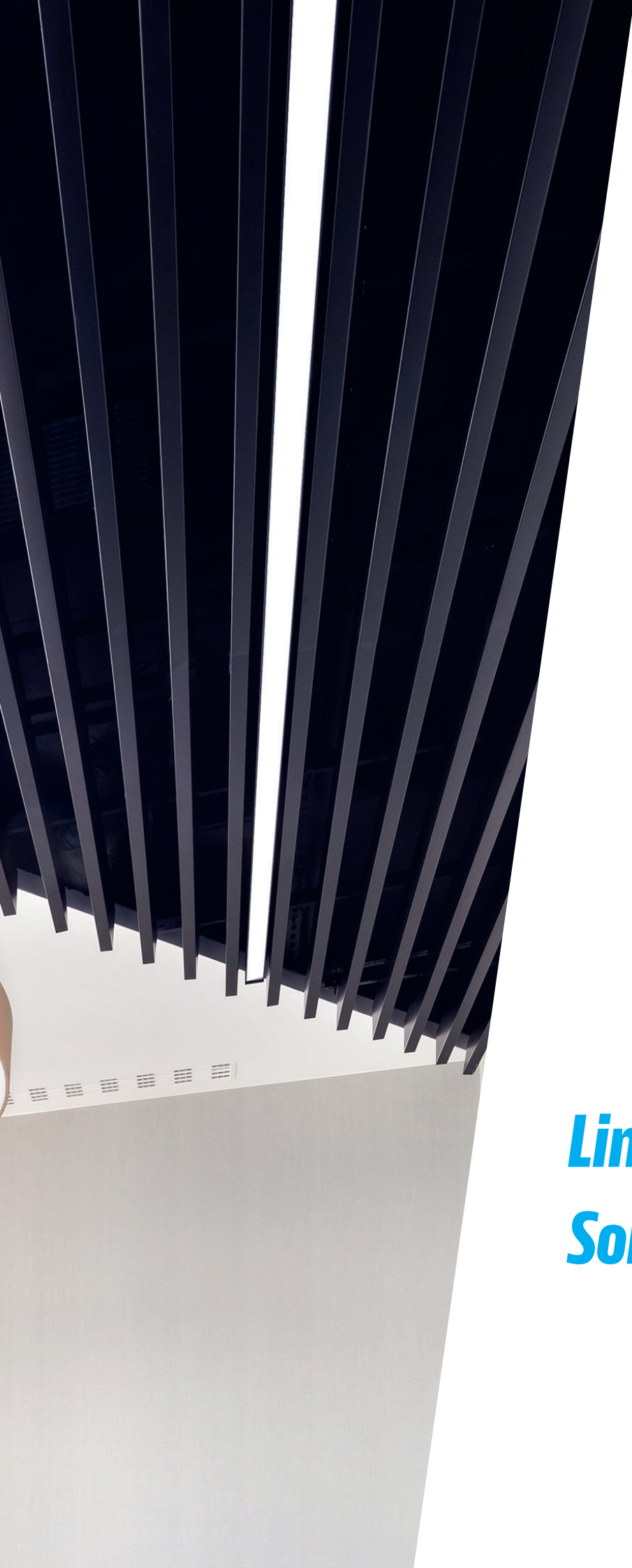

Linear & Baffle Solutions

METAL Baffle Element

U-Profile primary grid + hanger for baffle
Semi-exposed grid solution for indoor applications

General information

- Semi-exposed hook-on grid system for medium and large rooms
- Fully configurable solution with variable baffle spacing
- For perpendicular installation on U-Profile primary grid
- Typical ceiling weight 2.7 - 37.5 kg/m² (indicative value for unperforated baffles, without additional load)
- Baffles parallel aligned
- Baffles are easily installed and fully demountable
- Optional end caps for baffles

Isometric view

Select the suspension option E1 - E4.

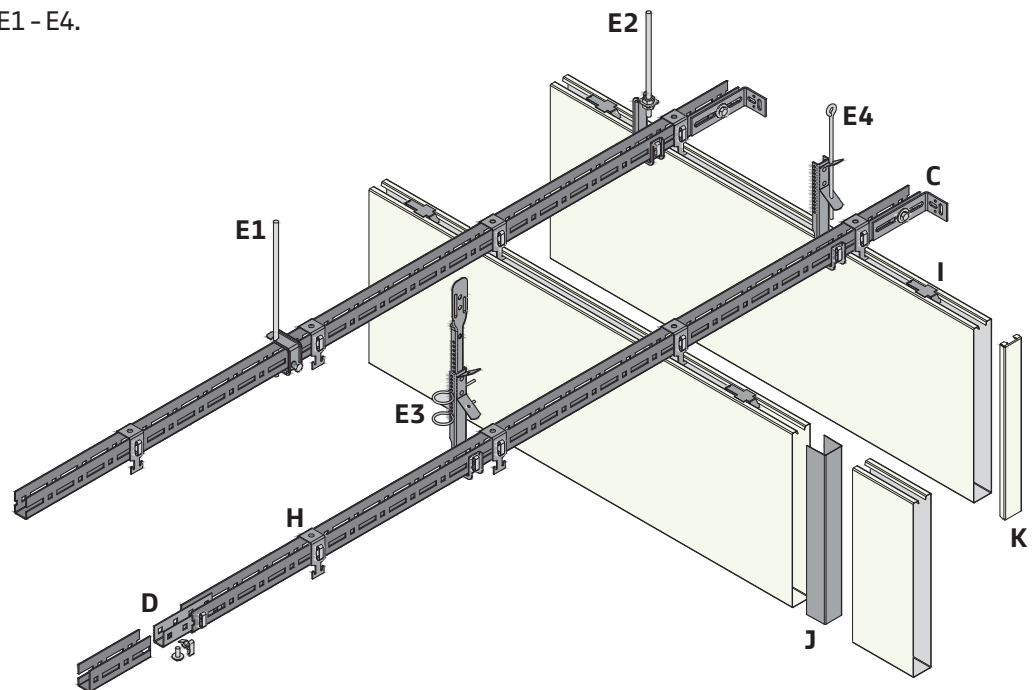

Vario Design & bespoke layout options

Vario Design

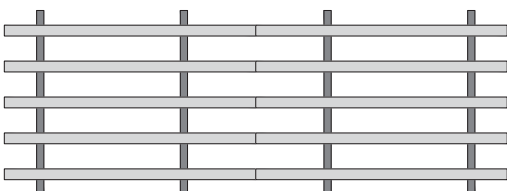

Bespoke (on request)

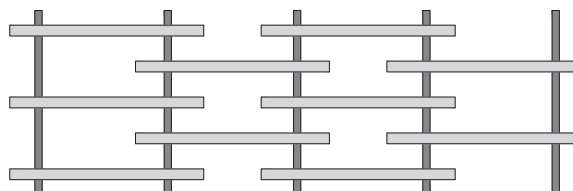

METAL Baffle Element

E02.100

Section F

Example with suspension option E1

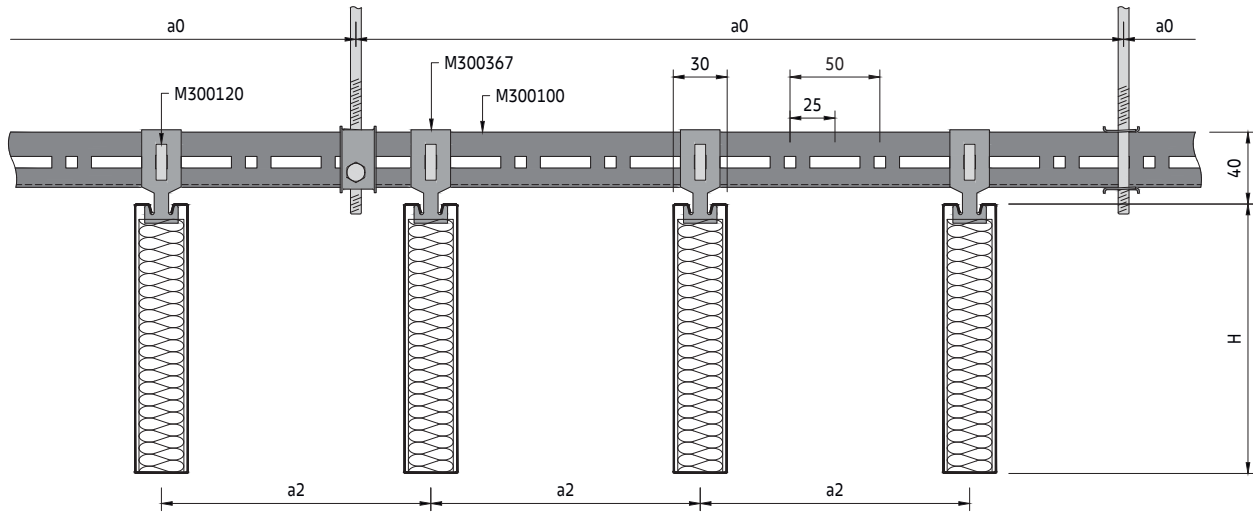

Section G

Example with suspension option E1

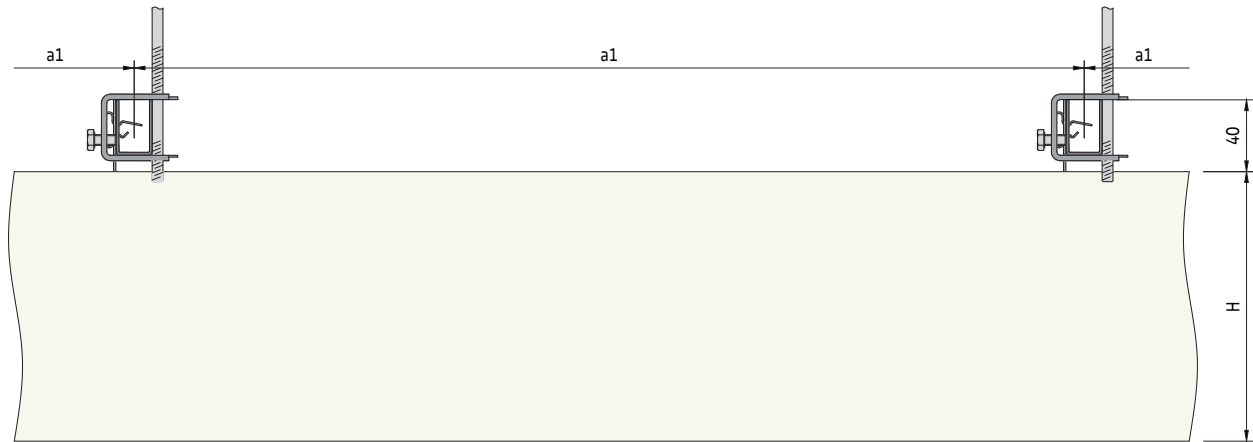

Secondary grid components

Standard components

- M300367BZC Hanger for baffle
- M311044 Distance holder for baffle
- M300120 Plug-in clip for U-Profile
- - Splice connector for baffle RAL 9005

Optional components

- - End cap for baffle
 - M311191 Self-drilling screw 3.5 x 9.5 mm
- See U-Profile primary grid for primary grid components

METAL Baffle Element

E02.100

Spacing

System without additional load * / baffle height (H) = 100 mm	
a2 [mm]	a0 [mm]
100	1000
200	1400
300	1600
400	1700
500	1800
600	1900
700	1900
800	1900
900	1900
1000	1900

System without additional load * / baffle height (H) = 150 mm	
a2 [mm]	a0 [mm]
100	900
200	1300
300	1500
400	1600
500	1750
600	1800
700	1900
800	1900
900	1900
1000	1900

System without additional load * / baffle height (H) = 200 mm	
a2 [mm]	a0 [mm]
100	800
200	1150
300	1400
400	1500
500	1650
600	1750
700	1800
800	1850
900	1900
1000	1900

System without additional load * / baffle height (H) = 250 mm	
a2 [mm]	a0 [mm]
100	750
200	1050
300	1300
400	1500
500	1600
600	1700
700	1750
800	1850
900	1900
1000	1900

System without additional load * / baffle height (H) = 300 mm	
a2 [mm]	a0 [mm]
100	700
200	1000
300	1200
400	1400
500	1550
600	1600
700	1700
800	1750
900	1850
1000	1900

* Including standard acoustic infill

Parameters

- a0 Distance between U-Profile suspension points = max. 1900 mm
- a1 Max. distance between U-Profiles = max. 1500 mm
- a2 Distance between baffles
- a3 Distance from wall = max. 200 mm
- a4 Distance from wall = min. 20 mm
- L Baffle length = max. 3000 mm
- H Baffle height = 100 / 150 / 200 / 250 / 300 mm
- W Baffle width = 20 / 30 / 40 / 50 / 60 mm

Typical grid layout

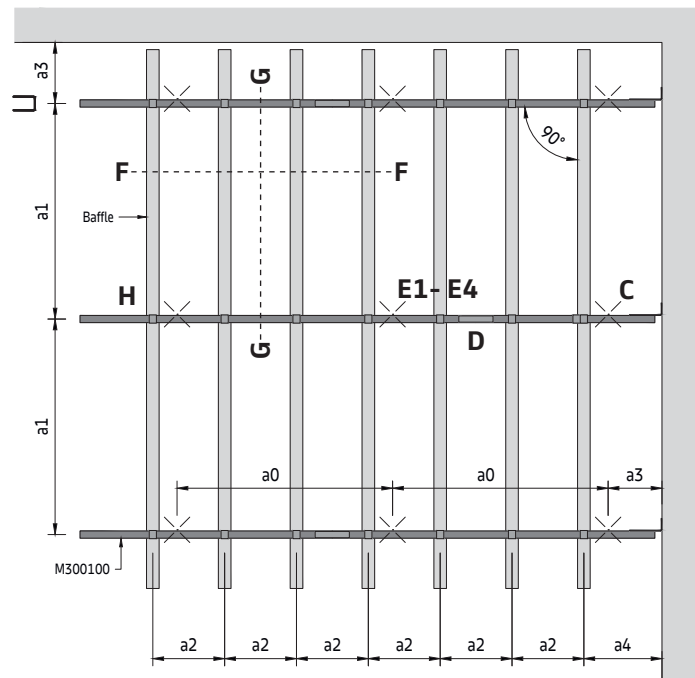

To determine suspension layout

The baffle distance (a2) and the baffle height (H) of the requested ceiling are the required values to determine suspension layout. Take (a1) as 1500 mm max.

On the appropriate spacing table for baffle height (H), read down the column headed (a2) to the required baffle spacing then read across to determine the suspension point spacing (a0).

The shown values are maximum allowed distances and can be reduced but not exceeded.

Detail H

Hanger installation

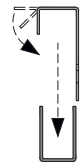
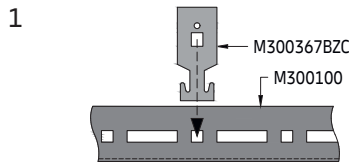

Place the hanger on the U-profile and bend the upper part 90° downwards.

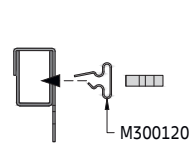
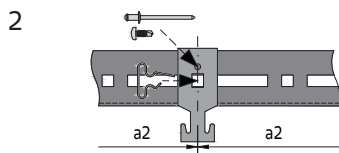

Fix it with plug-in clips at the specified module spacing (inserted vertically or horizontally). If the baffle distance does not fit with the modulation of the U-Profile (steps of 25 mm), the plug-in clip needs to be inserted into a long hole. The hanger position could be fixed by using a pop-rivet or self-drilling screw.

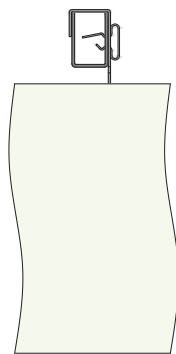
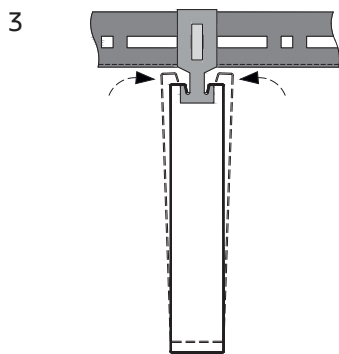

Hook the baffle on the hanger. The ends of the baffle are opened slightly. To prevent the baffles from being damaged by lateral pressure at the lower end, they are not rigidly connected to the hanger. The baffles are held in position by their own weight and therefore do not move due to an air flow or vibrations.

Detail I

Distance holder installation

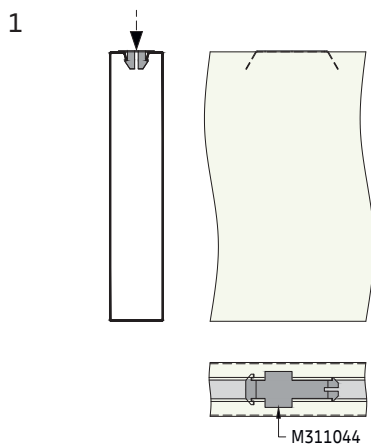

The distance holder is pushed into the top slot of the baffle from above. At least two pieces are required per baffle.

The distance holder keeps the top slot of the baffle at the correct dimension and parallel. This also prevents the baffles from becoming dislodged and falling.

METAL Baffle Element

E02.100

Detail J

Splice connection

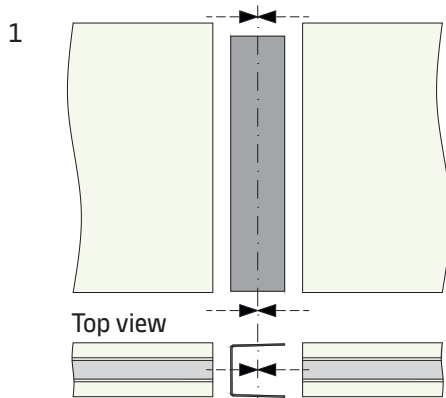

Place the splice connector between the ends of the baffles, as shown to the left. This will offset the acoustic infill slightly.

The splice connector results in a tight joint between baffles joined end on end and is supplied painted black to mask any separation of baffles. It is available in different sizes to suit baffle depths.

Detail K

End cap installation

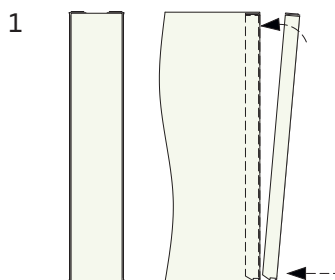

If the baffles are not installed continuously from wall to wall, end caps can be used to visibly close off the ends.

The lower end of the end cap is inserted first, followed by the upper end. The end cap is available in different sizes to suit baffle depths.

METAL Baffle Element

E02.100

Material required per m² (no waste included)**System without additional load, including standard acoustic infill [pcs/m²]**

Components		a2 [mm]	100	200	300	400	500	600	800	1000
M300100	U-Profile		0.18	0.18	0.18	0.18	0.18	0.18	0.18	0.18
M300119	Splice connector for U-Profile		0.18	0.18	0.18	0.18	0.18	0.18	0.18	0.18
M300120	Plug-in clip for U-Profile		7.03	3.70	2.59	2.03	1.70	1.48	1.20	1.03
M300140	Wall anchor		0.07	0.07	0.07	0.07	0.07	0.07	0.07	0.07
M300367BZC	Hanger for baffle		6.67	3.34	2.23	1.67	1.34	1.12	0.84	0.67
M311044	Distance holder for baffle		10.02	5.01	3.36	2.52	2.01	1.68	1.26	1.02
M311103	Hexagonal nut M6		0.10	0.10	0.10	0.10	0.10	0.10	0.10	0.10
M311105	Washer		0.10	0.10	0.10	0.10	0.10	0.10	0.10	0.10
M311303	Hexagonal bolt M6 x 16 mm		0.10	0.10	0.10	0.10	0.10	0.10	0.10	0.10
Various	Suspension points (E1 - E4) for (H) = 150 mm		0.75	0.52	0.45	0.42	0.39	0.38	0.36	0.36
Various	Suspension points (E1 - E4) for (H) = 200 mm		0.84	0.58	0.48	0.45	0.41	0.39	0.37	0.36
Various	Suspension points (E1 - E4) for (H) = 250 mm		0.89	0.64	0.52	0.45	0.42	0.40	0.37	0.36
Various	Suspension points (E1 - E4) for (H) = 300 mm		0.96	0.67	0.56	0.48	0.44	0.42	0.39	0.36

The shown quantities are theoretical and based on an ideal layout, without considering the actual room layout. The ideal layout is based on a calculation of 10 x 10 m (100 m²). This calculation does not allow any damage, spare nor wastage. The final quantities and type of suspension have to be checked before ordering. Soffit and wall fixings by others. Not including baffle splice connectors and end caps.

METAL Baffle Element

Hanging wire

Single suspended solution for indoor applications

General information

- Hanging wire for single suspension
- Typical ceiling weight 2.7 - 5.5 kg/m (indicative value for unperforated baffles, without additional load)
- Baffles are easily installed and fully demountable
- With end caps and optionally connected together
- Acoustic & design elements

Isometric view

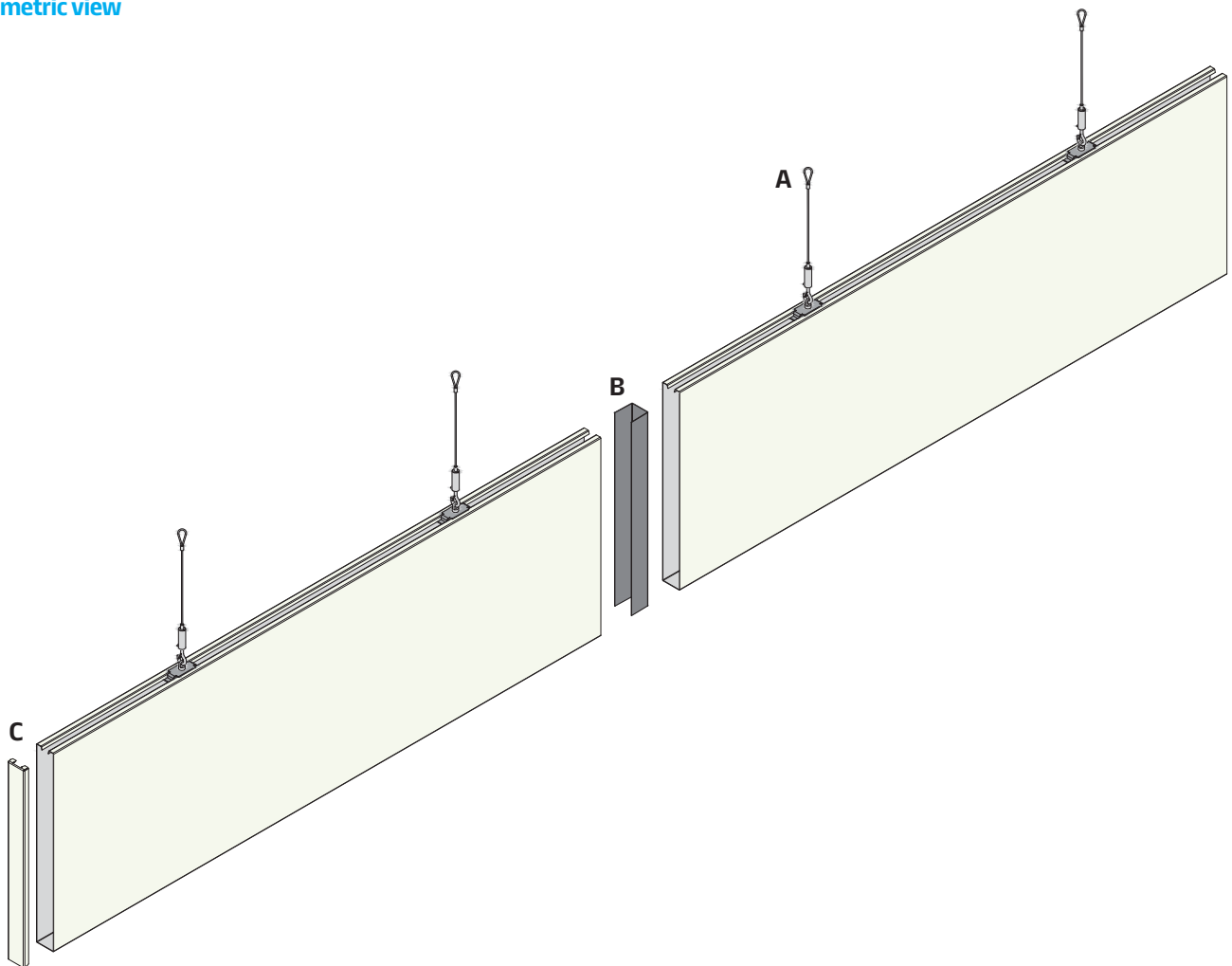

Standard layout options

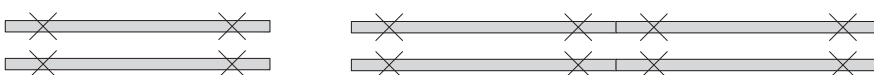

METAL Baffle Element

E02.100.1

Important information

This type of suspension is intended for a smaller number of baffles or if they are not to be aligned parallel. Grouping with the U-Profile is recommended for larger areas or where spacing is critical.

The hanging wires are supplied in a length of 4000 mm. If the room height is lower than this, the suspension points can be attached to the back of the baffle while it is on the ground. Please make sure that the visible side is protected during the assembly and cannot be scratched. In general, be careful when handling and transporting these large items.

The baffle was primarily designed for horizontal installation. Slight angles are possible, but the limit must be checked beforehand.

It is recommended to keep a lateral distance between the baffles of at least 100 mm and at the ends min. 30 mm if not connected.

This installation depends on the dimensions and configuration of the baffle.

Section F

Example with suspension option E1

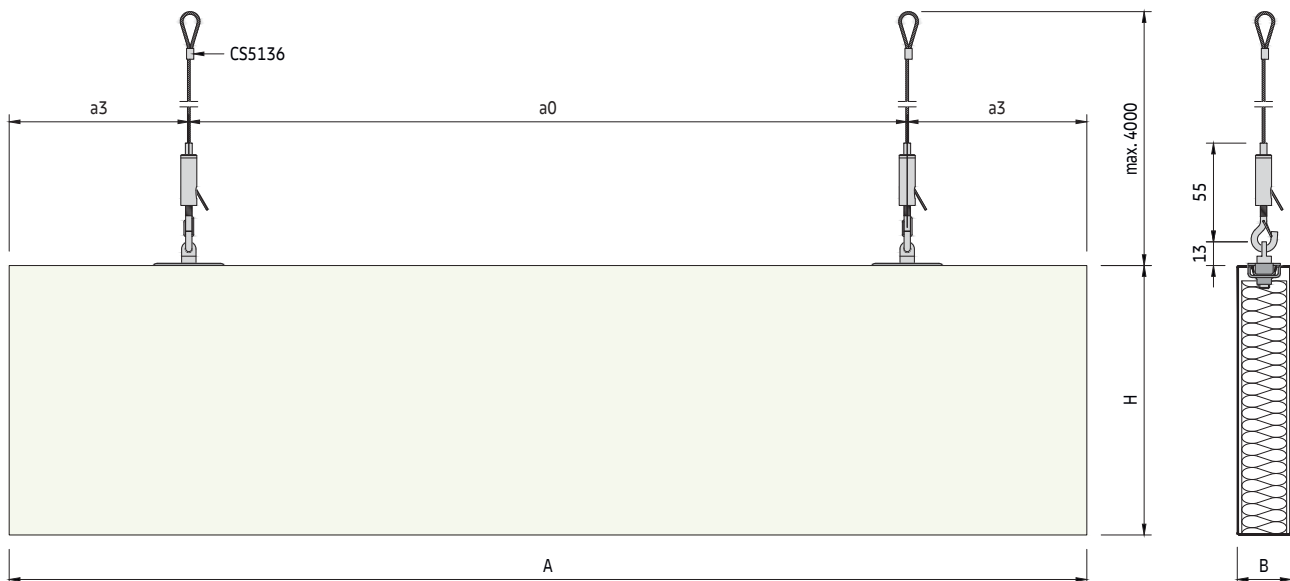

Parameters

a0	Distance between baffle suspension points = max. 1500 mm	L	Baffle length = max. 3000 mm
a3	Distance from baffle end = max. 300 mm	H	Baffle height = 100 / 150 / 200 / 250 / 300 mm
		W	Baffle width = 20 / 30 / 40 / 50 / 60 mm

Detail A

CS5136 Wire hanging installation

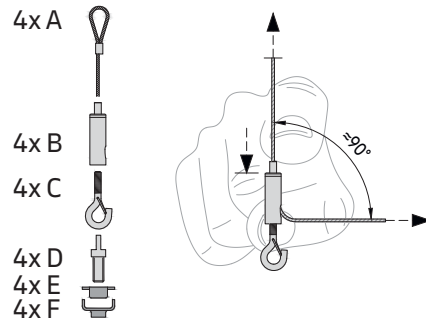

Take the eye bolt (D) and screw it through the top (E) and bottom part (F) of the suspension element. Leave a slight gap of ≈ 4 mm between the components.

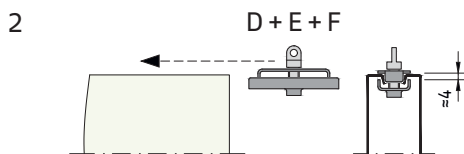

Slide this in from the baffle end. Lock the components with the eye bolt.

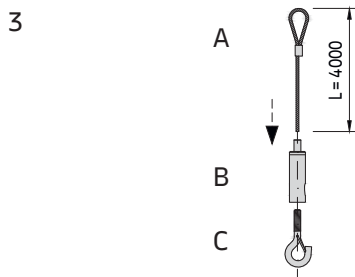

Screw the finishing hook (C) into the height adjuster (B). Guide the hanging wire (A) into the height adjuster (B). Pull the wire through the height adjuster, at an angle of $\approx 90^\circ$. Do not pull the wire upwards, otherwise it may be damaged. Fix the hanging wire to the soffit.

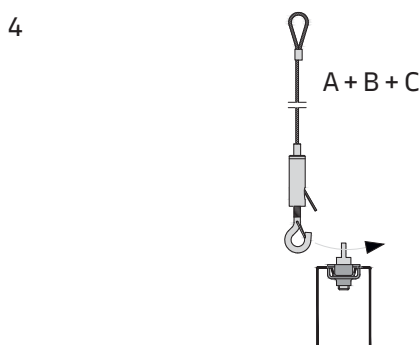

Take the baffle and hang it on the finishing hook. Min. two suspension points are needed per baffle.

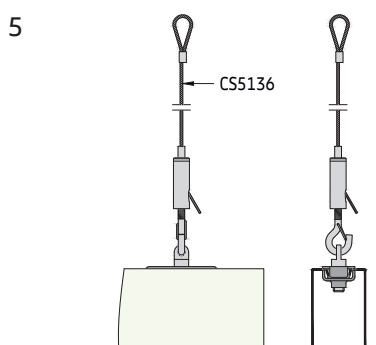

Then either roll up the wire and deposit it on the baffle or cut it away. After cutting it away, it can no longer be adjusted in height. Repeat this for all suspension points.

METAL Baffle Element

E02.100.1

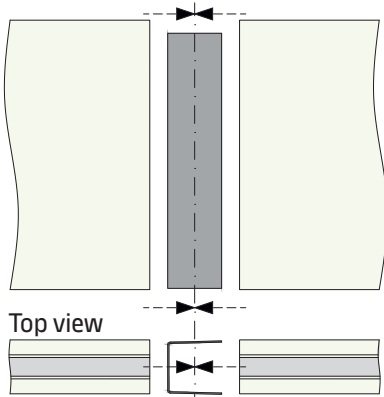
Detail B**Splice connection**

Place the splice connector between the ends of the baffles, as shown to the left. This will offset the acoustic infill slightly.

The splice connector is black coated and prevents an open joint where the light can shine through. It is available in different sizes.

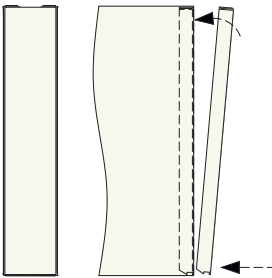
Detail C**End cap installation**

If the baffles are not installed continuously from wall to wall, end cap can be used to visibly close off the ends.

The lower end of the end cap is inserted first, followed by the upper end. The end cap is available in different sizes.

Components**Standard components**

- CS5136 Wire hanging for METAL Baffle Element
- - End cap for baffle

Optional components

- - Splice connector for baffle RAL 9005

METAL Linear Lite

Carrier

Semi-exposed grid solution for indoor applications

General information

- Semi-exposed grid system for medium and large rooms
- Typical ceiling weight 2.5 - 3.5 kg/m² (indicative value, without additional load)
- Baffles parallel aligned and made out of pre-coated aluminium
- Baffles are easily installed and fully demountable
- Optional end caps for 20 mm wide baffles

Isometric view

Select the suspension option C1 - C3.

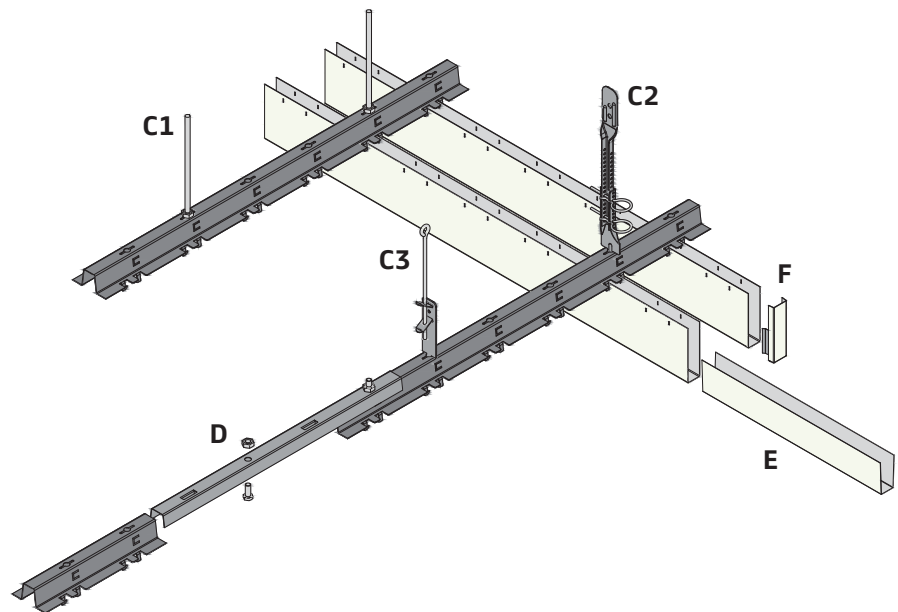

Important information

The carriers must be aligned so that the baffles can be easily attached.

Make sure that the suspension points are set precisely. This will make the installation of the baffles much easier.

Standard layout

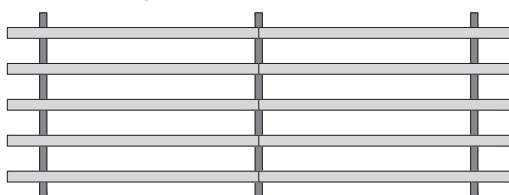

Standard sizes

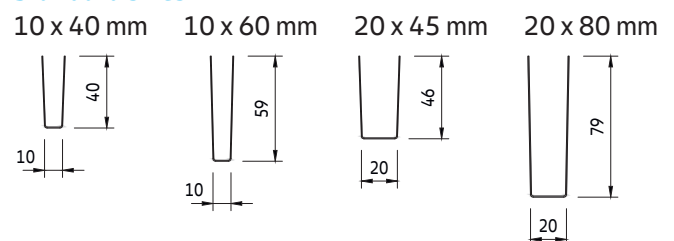

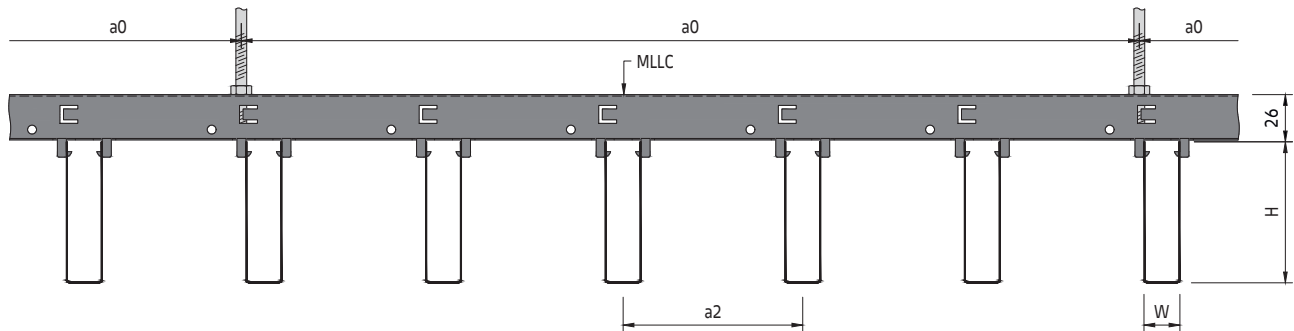
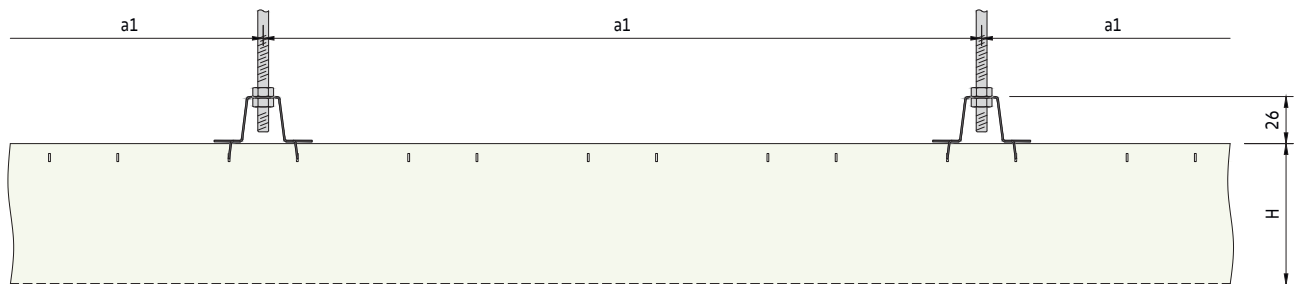
Section A**Example with suspension option C1****Section B****Example with suspension option C1****Grid components****Standard components**

- MLL10050C Carrier (for baffle 10 x 40, 50 mm spacing)
- MLL10075C Carrier (for baffle 10 x 60, 75 mm spacing)
- MLL20075C Carrier (for baffle 20 x 45, 75 mm spacing)
- MLL20100C Carrier (for baffle 20 x 80, 100 mm spacing)
- MLLB50CS Splice connector for Carrier (for baffle spacing 50 mm)
- MLLB75CS Splice connector for Carrier (for baffle spacing 75 mm)
- MLLB100CS Splice connector for Carrier (for baffle spacing 100 mm)
- M311103 Hexagonal nut M6
- M311303 Hexagonal bolt M6 x 16 mm
- MLL1040S Splice connector for baffle 10 x 40 mm (various colours)
- MLL1060S Splice connector for baffle 10 x 60 mm (various colours)
- MLL2045S Splice connector for baffle 20 x 45 mm (various colours)
- MLL2080S Splice connector for baffle 20 x 80 mm (various colours)

Optional components

- MLL2045E End cap for baffle 20 x 45 mm (various colours)
- MLL2080E End cap for baffle 20 x 80 mm (various colours)

Suspension option C1

- M311101 Threaded rod
M6 x 1000 mm
- M311103 Hexagonal nut M6
- M311315 Hexagonal extension nut
M6 x 30 mm (optional)
- M311061 Suspension element
(optional)

Suspension option C2

- MLLBN Nonius hanger for Carrier
- - Nonius top part
(various lengths)
- M300036 Nonius locking pin

Suspension option C3

- MLLBR Quick hanger for Carrier
- - Eye wire (various lengths)

Carrier

MLL10050C for baffle size 10 x 40 mm, carrier module length (CM) = 4000 mm

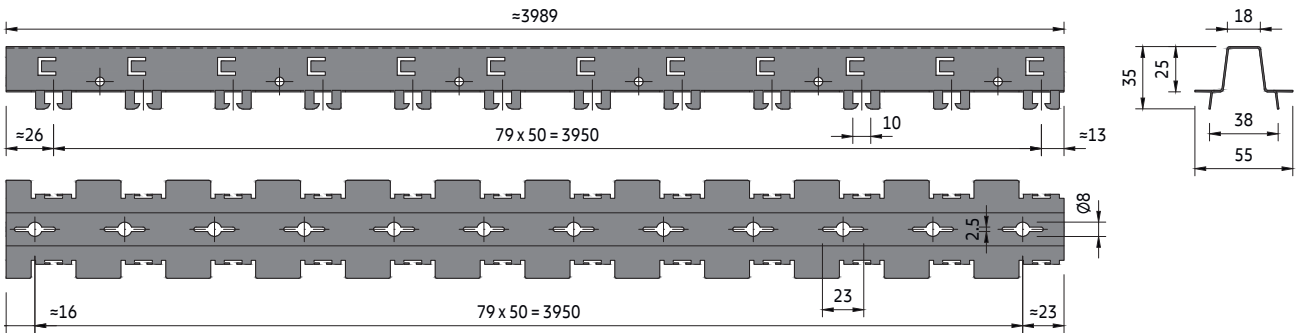

MLL10075C for baffle size 10 x 60 mm, carrier module length (CM) = 3975 mm

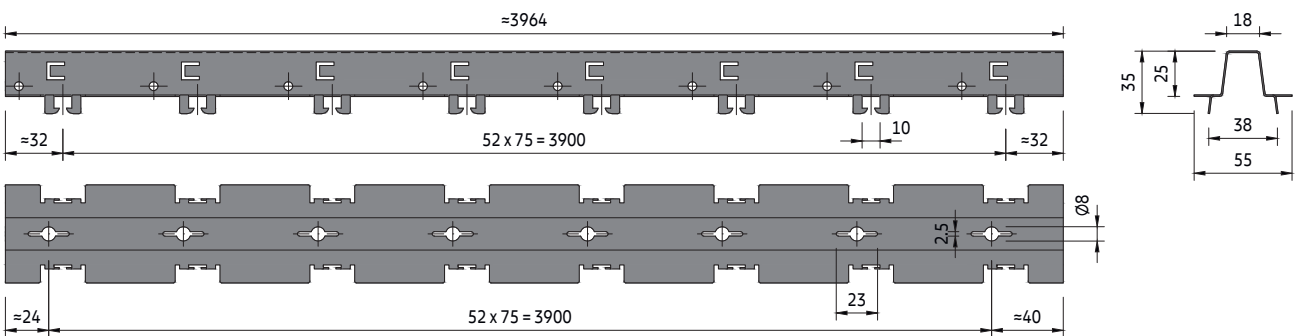

MLL20075C for baffle size 20 x 45 mm, carrier module length (CM) = 3975 mm

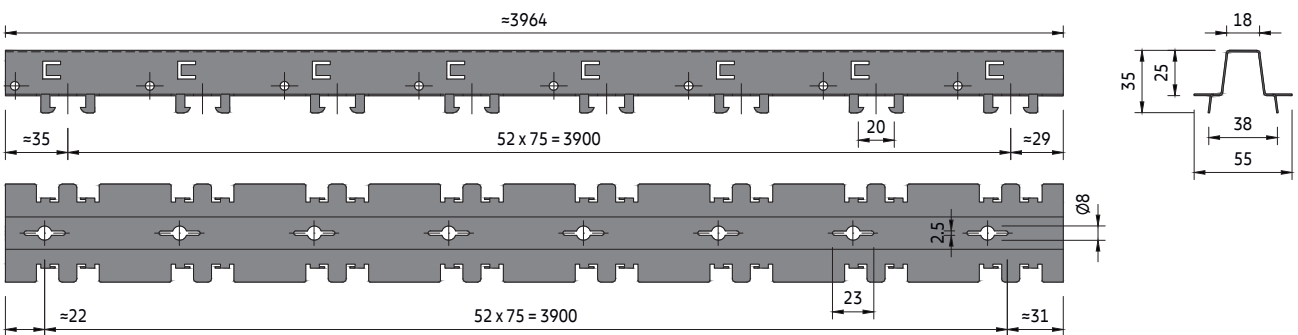

MLL20100C for baffle size 20 x 80 mm, carrier module length (CM) = 4000 mm

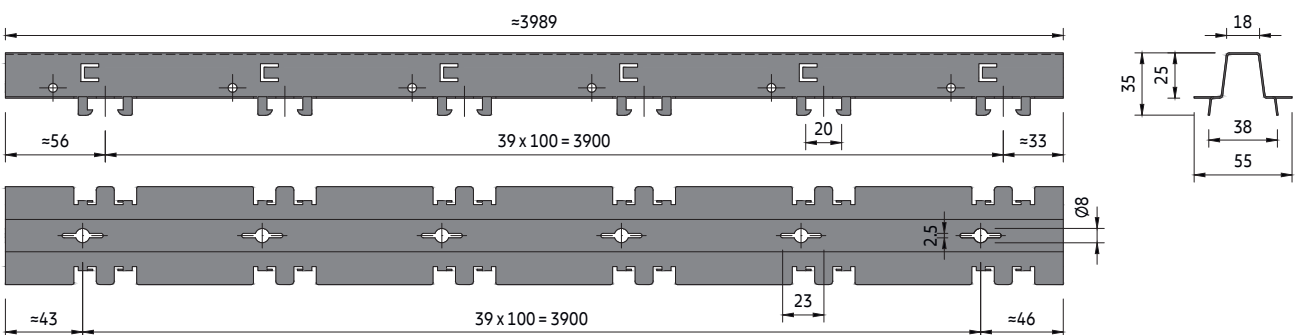

Typical grid layout

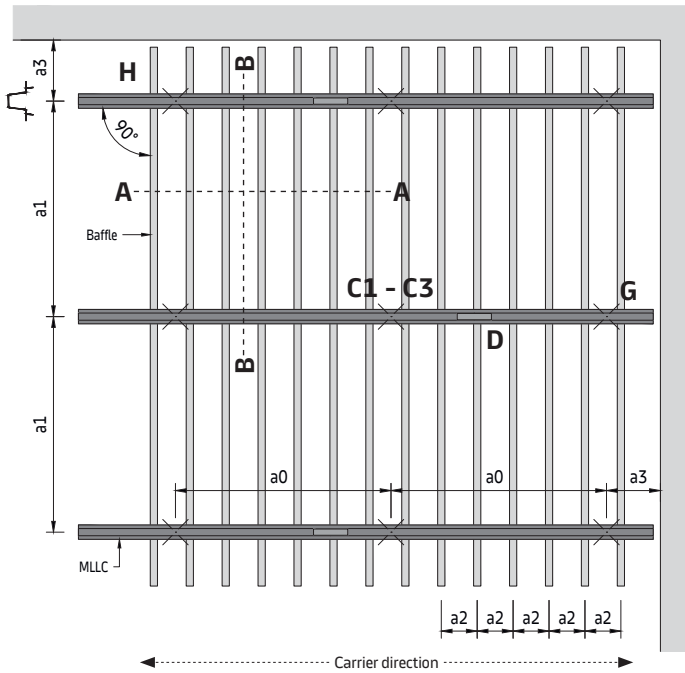

Parameters

- a0 Distance between carrier suspension points = max. 1200 mm (the hole spacing on top of the carrier is equal to the baffle spacing (a2))
- a1 Max. distance between carriers = max. 1300 mm (the distance depends on the baffle length (L), in steps of 100 mm)
- a2 Distance between baffles
 - baffle size (W x H) 10 x 40 mm = 50 mm
 - baffle size (W x H) 10 x 60 mm = 75 mm
 - baffle size (W x H) 20 x 45 mm = 75 mm
 - baffle size (W x H) 20 x 80 mm = 100 mm
- a3 Distance from wall = max. 200 mm
- CM Carrier module length = 3975 / 4000 mm
- L Baffle length = 4000 mm
- W Baffle width
- H Baffle height

The shown values are maximum allowed distances and can be reduced but not exceeded.

Carrier spacing for standard baffle length

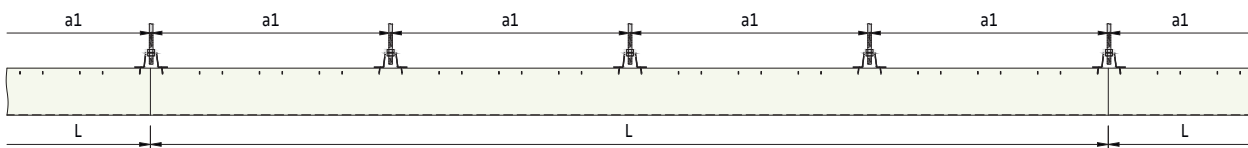

The carrier distance (a1) should be chosen so that it is located at each baffle joint. Sufficient carriers must be used so that the maximum allowed distance for (a1) is not exceeded. For a standard baffle length (L) of 4000 mm, 4x carriers must be placed at a distance (a1) of 1000 mm.

Detail C

Suspension options

Option C1

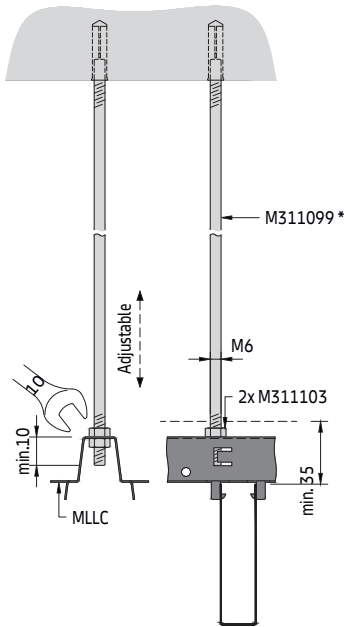

Option C2

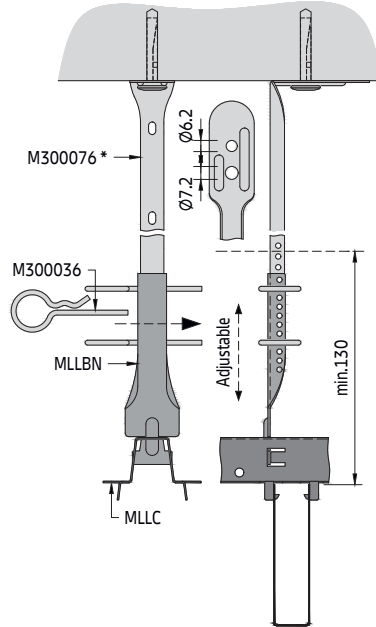

Option C3

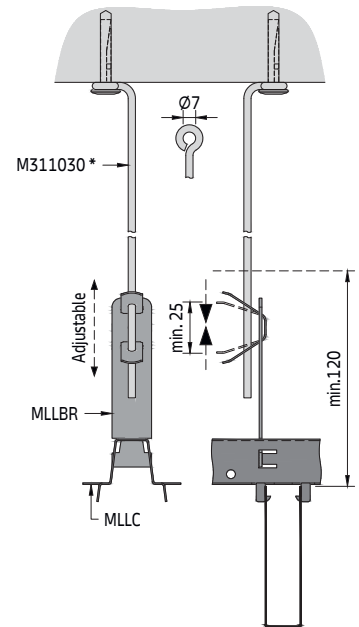

The Nonius hanger (C2) and the quick hanger (C3) are inserted into the carrier from above and rotated by 90°. The lower end snaps into the tabs and secures it. The clip (C3) should only be compressed as indicated to avoid possible damage.

Detail C4

Optional top fixing and extension detail suspension option C1

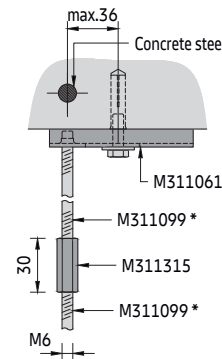

* Various lengths available

Detail D

Carrier splice connection

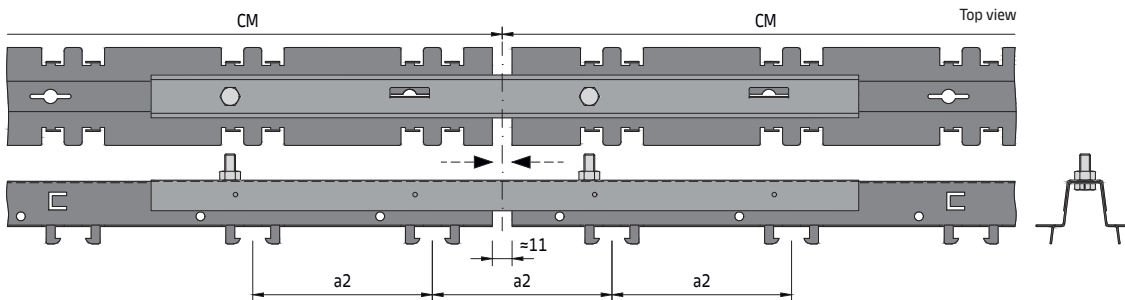

The splice connector is placed between the two ends of the carriers. Use two M6 bolts and nuts to fix it. The carriers are manufactured shorter so that a gap is created between the carriers when installed. This ensures that the spacing (a2) is continued. Depending on the baffle size and distance (a2), the appropriate splice connector must be selected. The position of the suspension points must not be on a connection. Keep this in mind when planning.

Detail E
Baffle splice connection

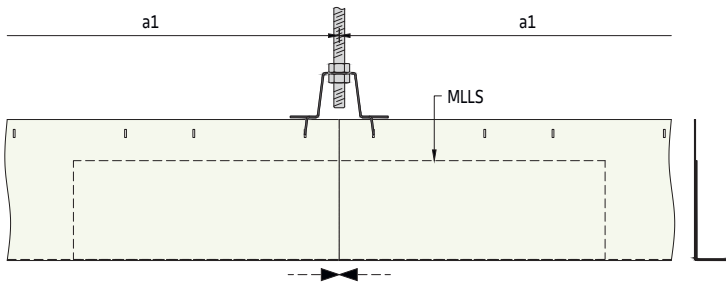

In order to obtain a more stable and straight alignment, baffles are coupled at the carrier using a splice connector.

Splice connector for 10 mm baffle = 195 mm length

Splice connector for 20 mm baffle = 296 mm length

Detail F
End cap installation

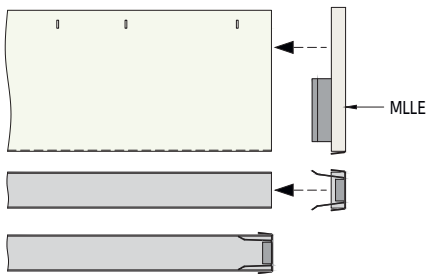

If the baffles are not installed continuously from wall to wall, end caps can be used to visibly close off the ends.

Squeeze the spring slightly so that the end cap can be inserted.

The end cap is available only for the 20 mm wide baffles.

Detail G
Carrier to wall

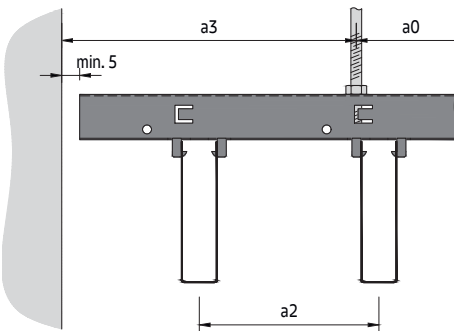

The distance between the carrier and the wall can be freely selected. However, a distance of at least 5 mm should be maintained.

If necessary, use wall anchors to fix the position of the carrier. Where this is not possible, work with angle bracings.

Detail H
Carrier to wall

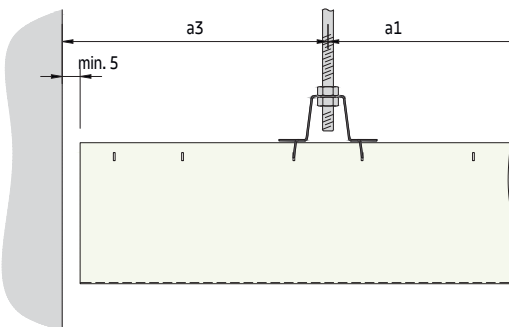

The distance between the baffle and the wall can be freely selected. However, a distance of at least 5 mm should be maintained.

For a larger distance, the open end of the baffle can be covered with an end cap on the 20 mm wide version.

See detail F

Detail I

Baffle insertion

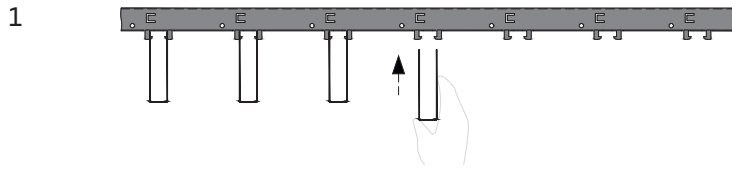

Carefully remove the protective film without damaging the baffle. Insert the baffle from below.

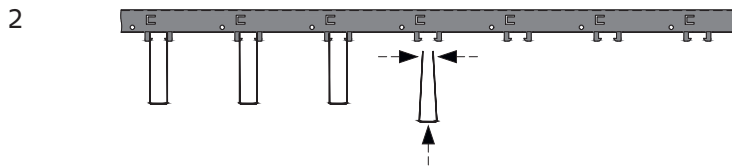

Gently press the baffle together at the top so that it can be attached.

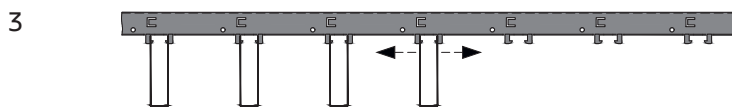

Once the baffle is in position, the hooks can be inserted into the slots provided.

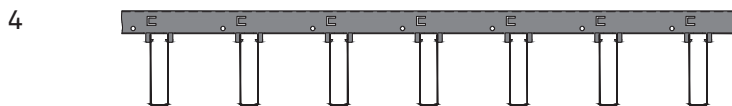

Insert baffle after baffle and connect them with the splice connectors.

Baffle extraction

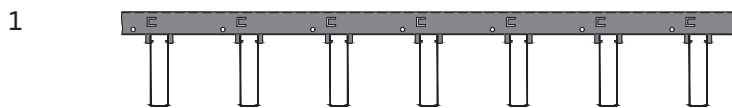

Any baffle can be removed as long as there are no obstacles such as service integrations, etc.

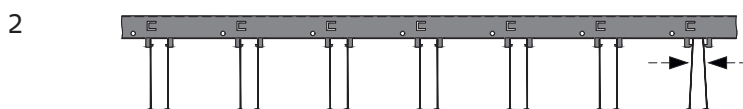

Gently press the baffle together at the top so that it can be disattached.

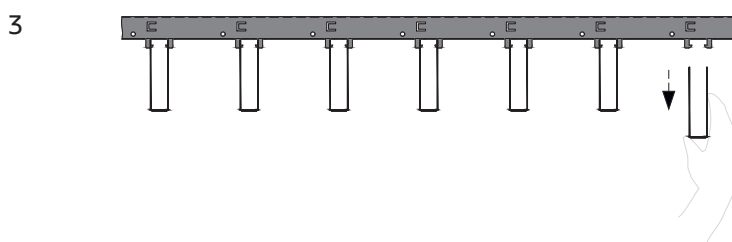

Remove it downwards and store the baffle in a safe place so that it cannot be damaged.

Detail J

Connection to columns

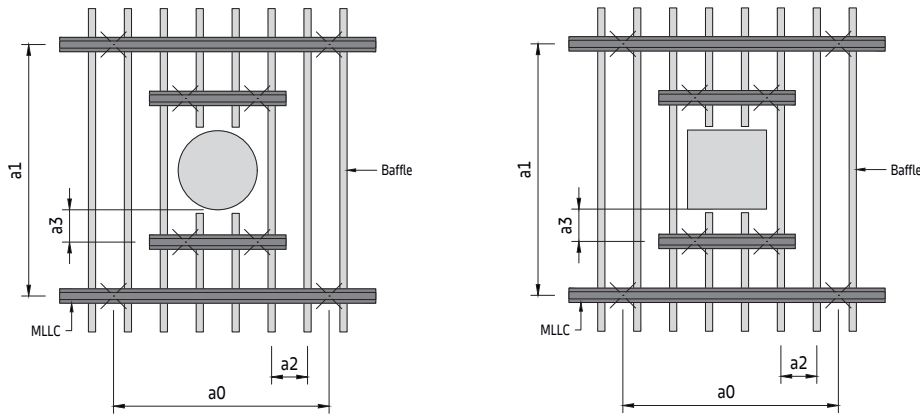

The baffles are connected to columns with a minimum distance of 5 mm. There is no provision for fastening the baffle. To ensure that the baffles are guided and installed safely, additional carriers must be placed on both sides of the column. These should be long enough to run over a continuous baffle at both ends. The distance from the carrier to the column should not exceed (a3).

Service integrations

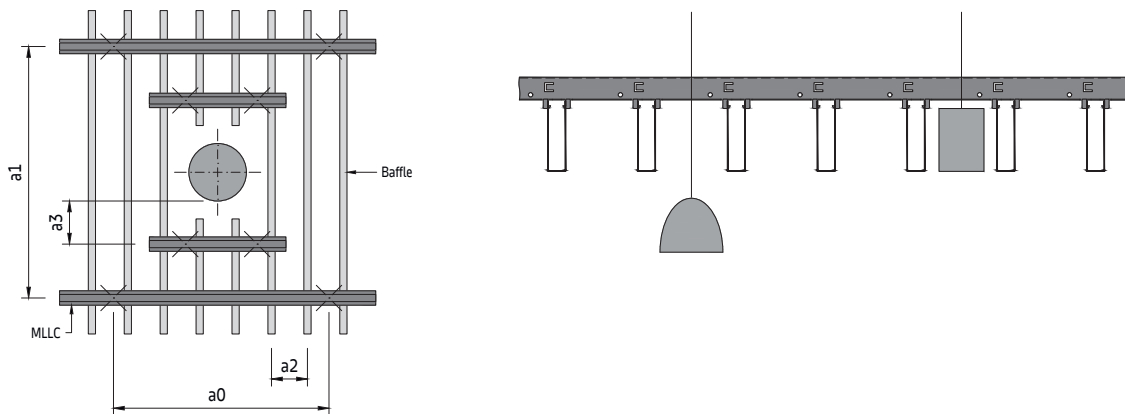

As soon as the service integrations are larger than the distance between the baffles, the detail must be solved in the same way as for a column connection. Smaller service integrations can be suspended between the baffles (e.g. pendant lights, signs, etc.) or placed between the baffles (the service integration should not touch the baffles). All service integrations must be suspended separately and should not be fixed to the carrier.

Material required per m² (no waste included)**System without additional load [pcs/m²]**

Components		baffle size [mm]	10 x 40	10 x 60	20 x 45	20 x 80
Various	Carrier		0.21	0.21	0.21	0.21
Various	Splice connector for Carrier		0.21	0.21	0.21	0.21
Various	Baffle 4000 mm		5.00	3.33	3.33	2.50
Various	Splice connector for baffle		5.00	3.33	3.33	2.50
M311103	Hexagonal nut M6		0.42	0.42	0.42	0.42
M311303	Hexagonal bolt M6 x 16 mm		0.42	0.42	0.42	0.42
Various	Suspension points (C1 - C3)		0.64	0.64	0.64	0.64

The shown quantities are theoretical and based on an ideal layout, without considering the actual room layout. The ideal layout is based on a calculation of 10 x 10 m (100 m²). This calculation does not allow any damage, spare nor wastage. The final quantities and type of suspension have to be checked before ordering. Soffit or wall fixings by others. Not including baffle end caps.

General installation sequence

- The position of the suspension points must be marked on the soffit before installation (laser, measuring tape, chalk line, etc.). Then drill the holes and place the top fixing (not offered by Knauf Ceiling Solutions).
- Set threaded rods, Nonius top parts or eye wires, shorten if necessary.
- Wherever possible, fixing should begin on the centre axis of the ceiling area.
- Suspension options:
 - C1** - Align the height of the carrier and fasten it to the threaded rod with two hexagonal nuts.
 - C2** - Insert the Nonius hanger into the carrier from above and rotate by 90°. Align the height of the Nonius hanger and fasten it to the Nonius top-part with two safety clips.
 - C3** - Insert the quick hanger into the carrier from above and rotate by 90°. Align the height of the quick hanger and fasten it to the eye wire.

The minimum installation height is depending on the selected suspension option **C1-C3**.
- Carriers should be aligned with each other in the longitudinal direction and joints should be offset. Couple the carriers with splice connectors.
- Attach baffles and couple them with splice connectors. Baffles can be cut to length on site. Care should be taken not to damage them.
- Service integrations and additional loads must be suspended separately from the soffit. The additional measures must be carried out professionally.



METAL Linear Blade

Carrier

Semi-exposed grid solution for indoor applications

General information

- Semi-exposed grid system for medium and large rooms
- Typical ceiling weight 2.0 - 3.5 kg/m² (indicative value, without additional load)
- Blades parallel aligned and made out of pre-coated aluminium
- Blades are easily installed and fully demountable
- Overlapping or gapped layout option

Isometric view

Select the suspension option C1 - C3.

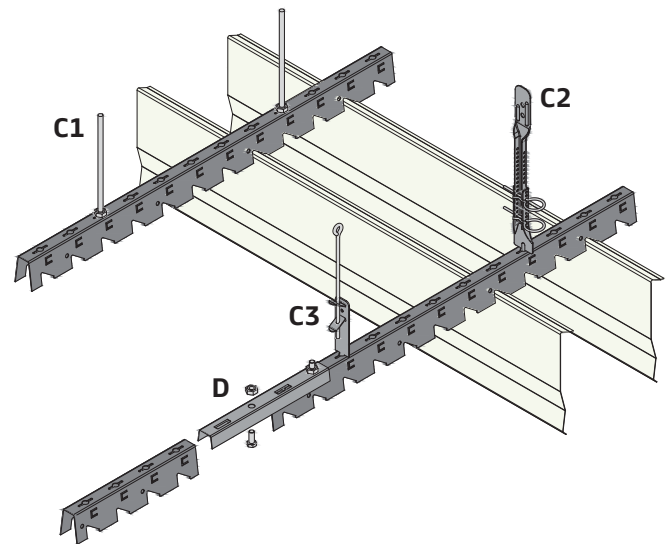

Important information

The carriers must be aligned so that the baffles can be easily attached. Make sure that the suspension points are set precisely. This will make the installation of the baffles much easier.

Standard sizes

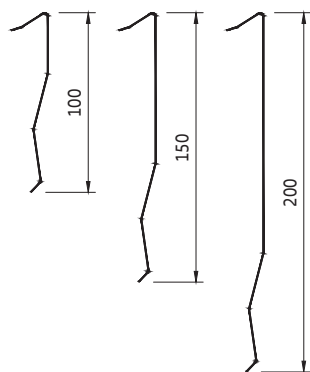

Standard layout options

Overlapping

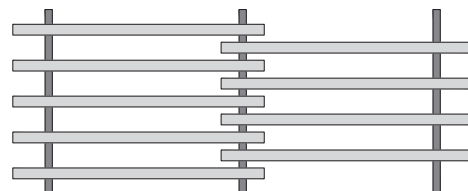

Gapped

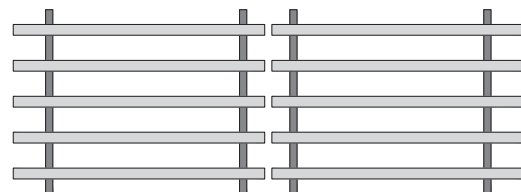

Section A

Example with suspension option C1

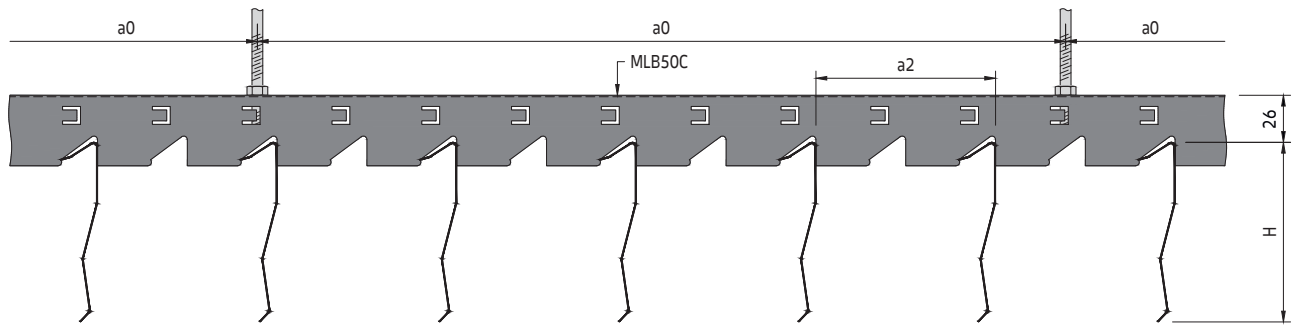

Different blade heights can be combined

Section B

Example with suspension option C1

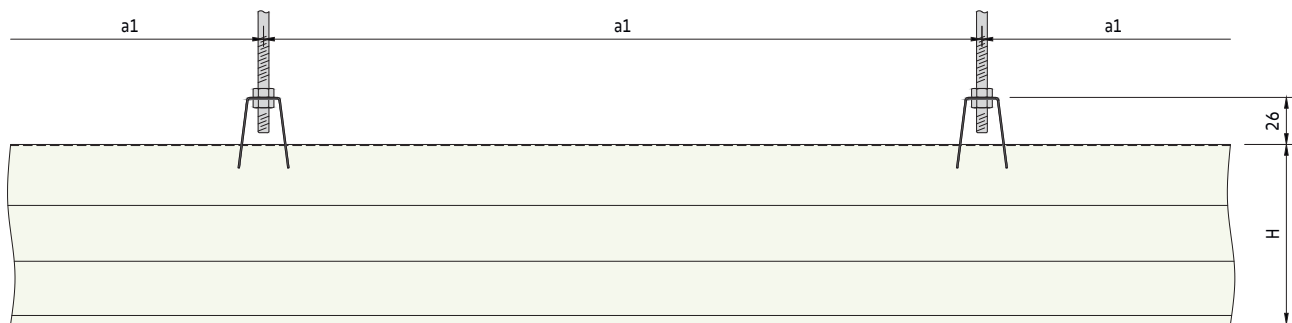

Grid components

Standard components

- MLB50C Carrier
- MLLB50CS Splice connector for Carrier
- M311103 Hexagonal nut M6
- M311303 Hexagonal bolt M6 x 16 mm

Suspension option C1

- M311101 Threaded rod M6 x 1000 mm
- M311103 Hexagonal nut M6
- M311315 Hexagonal extension nut M6 x 30 mm (optional)
- M311061 Suspension element (optional)

Suspension option C2

- MLLBN Nonius hanger for Carrier
- - Nonius top part (various lengths)
- M300036 Nonius locking pin

Suspension option C3

- MLLBQ Quick hanger for Carrier
- - Eye wire (various lengths)

Carrier

MLB50C

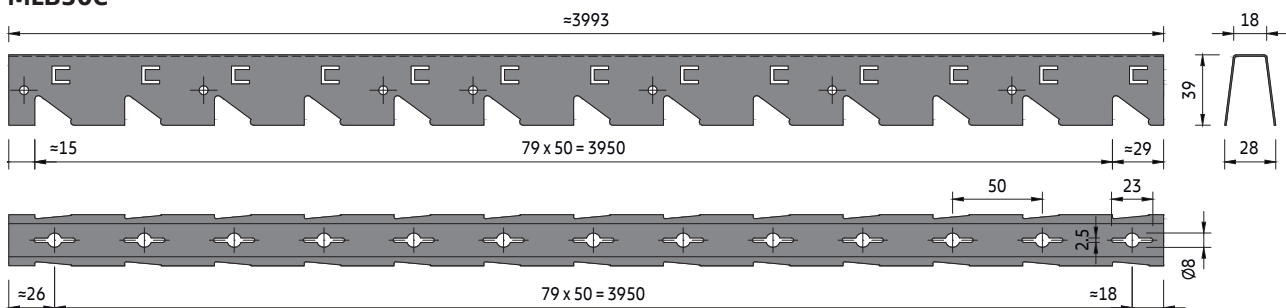

METAL Linear Blade

E02.311

Typical grid layout (overlapping option)

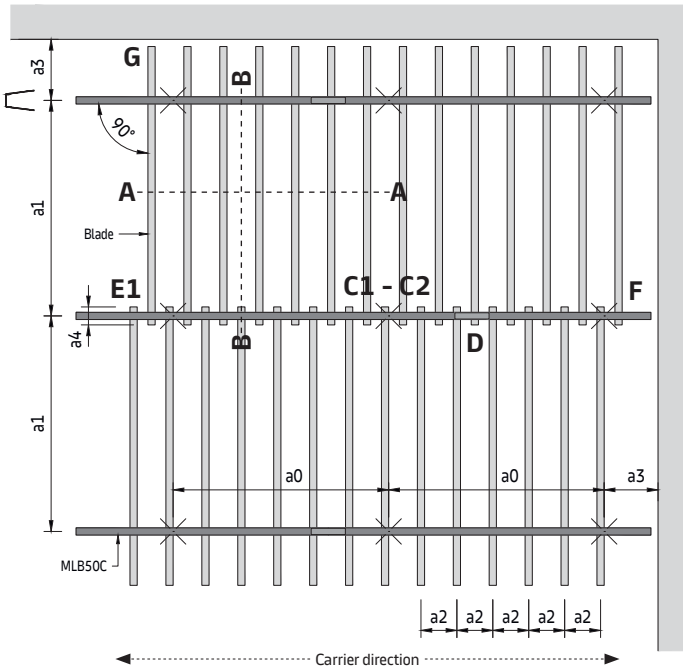

Parameters

- a0 Distance between carrier suspension points = max. 1200 mm (the hole spacing on top of the carrier is equal to the blade spacing (a2))
- a1 Max. distance between carriers = max. 1600 mm
- a2 Distance between blades = min. 100 mm
 recommendation for
 blade 100 mm = 100 mm
 blade 150 mm = 100 or 200 mm
 blade 200 mm = 200 mm
- a3 Distance from wall = max. 200 mm
- a4 Blade overlap = min. 78 mm
- CM Carrier module length = 4000 mm
- L Blade length = 4000 mm
- H Blade height
- M Baffle module length

The shown values are maximum allowed distances and can be reduced but not exceeded.

Detail E1

Overlapping option

When planning, it must be taken into account that this option requires more linear meters of blade (+a4 per blade length).

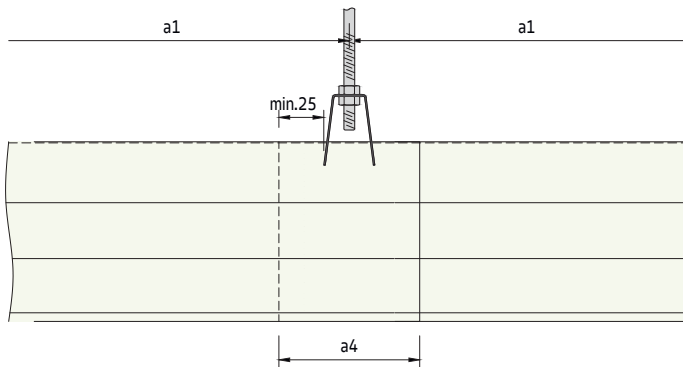

Layout

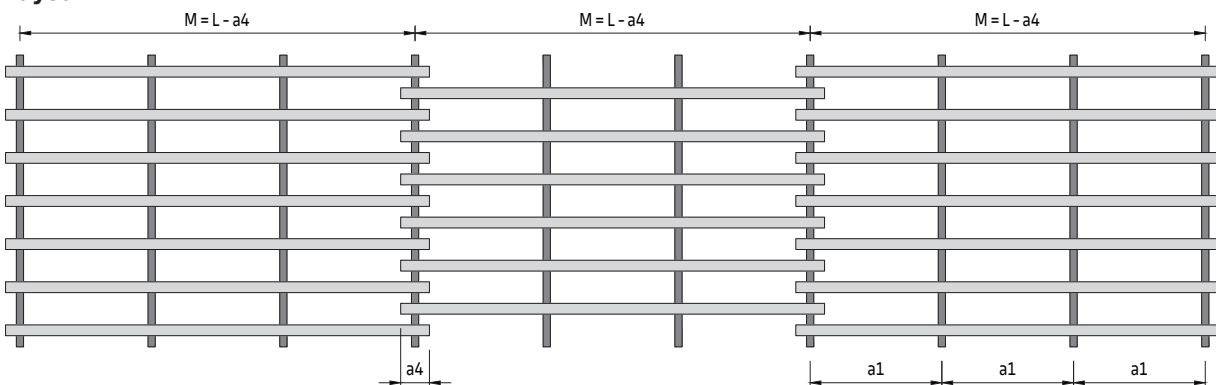

Example with standard baffle length (L) 4000 mm: If (a4) = 100 mm, (M) = 3900 mm and (a1) = 1300 mm

Typical grid layout (gapped option)

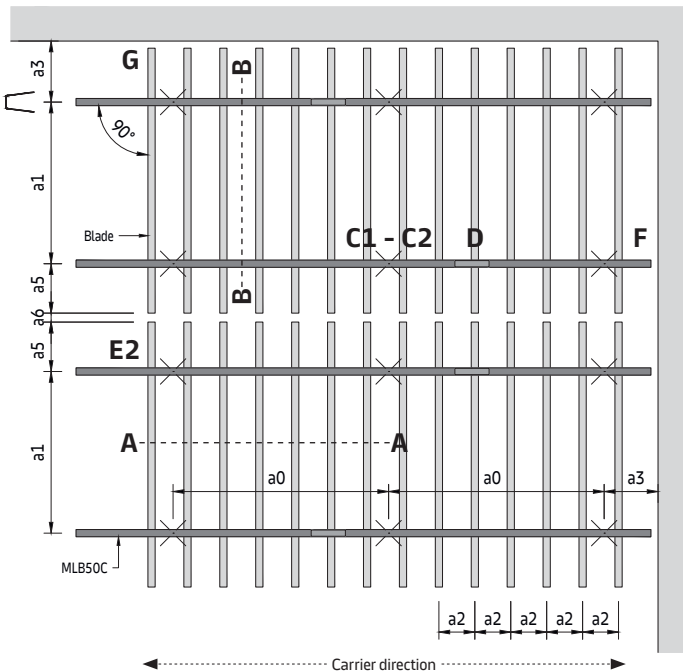

Parameters

- a0 Distance between carrier suspension points = max. 1200 mm (the hole spacing on top of the carrier is equal to the blade spacing (a2))
- a1 Max. distance between carriers = max. 1600 mm
- a2 Distance between blades = min. 100 mm recommendation for
blade 100 mm = 100 mm
blade 150 mm = 150 mm
blade 200 mm = 200 mm
- a3 Distance from wall = max. 200 mm
- a5 Distance from carrier to blade end = max. 300 mm
- a6 Distance between blade ends = min. 25 mm
- CM Carrier module length = 4000 mm
- L Blade length = 4000 mm
- H Blade height
- M Baffle module length

The shown values are maximum allowed distances and can be reduced but not exceeded.

Detail E2

Gapped option

When planning, it must be taken into account that this option requires less linear meters of blade (-a6 per blade length).

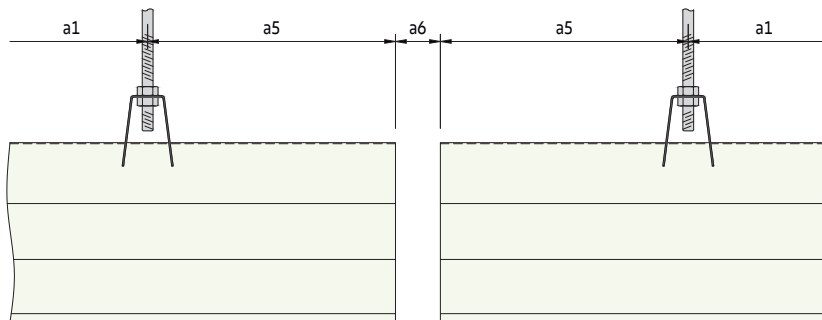

Layout

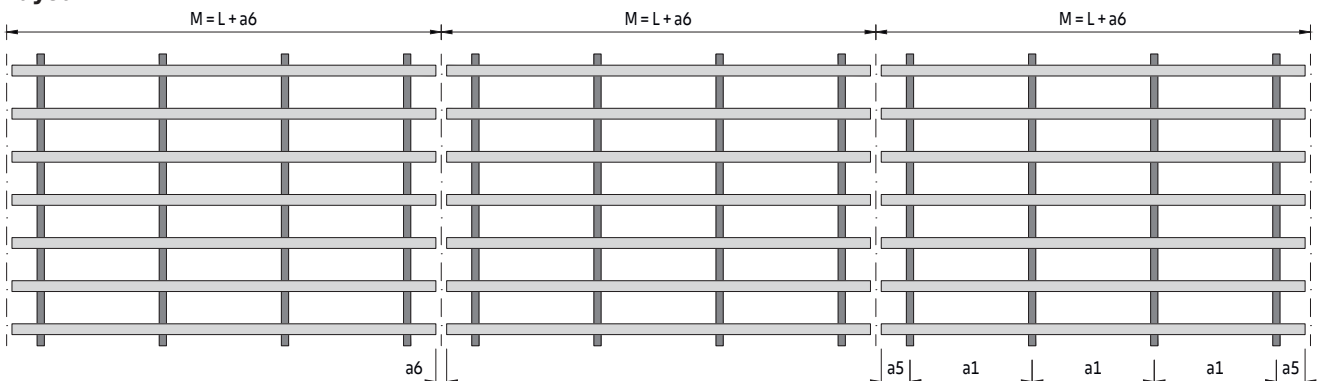

Example with standard baffle length (L) 4000 mm: If (a6) = 25 mm, (M) = 4025 mm, (a1) = 1200 mm and (a5) = 212.5 mm

Detail C

Suspension options

Option C1

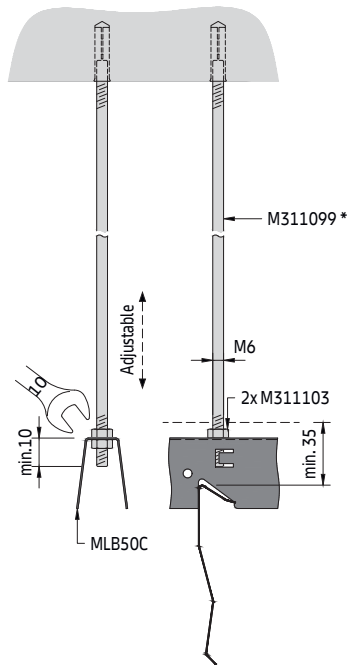

Option C2

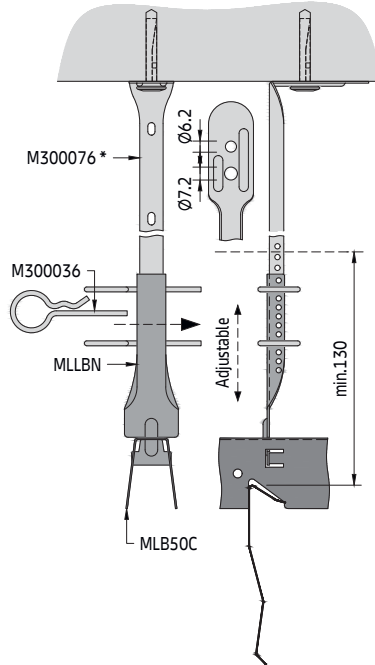

Option C3

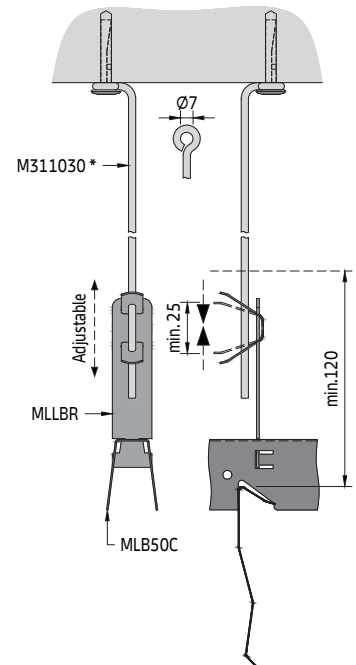

Make sure that the suspension points are set precisely. This will make the installation of the blades much easier. The Nonius hanger (C2) and the quick hanger (C3) are inserted into the carrier from above and rotated by 90°. The lower end snaps into the tabs and secures it. The clip (C3) should only be compressed as indicated to avoid possible damage.

Detail C4

Optional top fixing and extension detail for suspension option C1

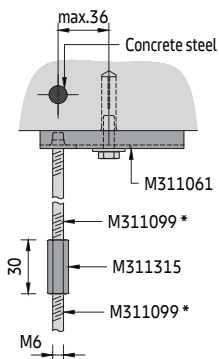

* Various lengths available

Detail D
Carrier splice connection

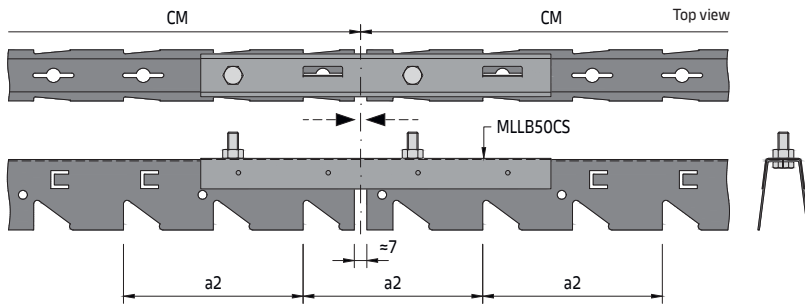

The splice connector is placed between the two ends of the carriers. Use two M6 bolts and nuts to fix it. The carriers are manufactured shorter so that a gap is created between the carriers when installed. This ensures that the spacing (a2) is continued.

The position of the suspension points must not be on a connection. Keep this in mind when planning.

Detail F
Carrier to wall

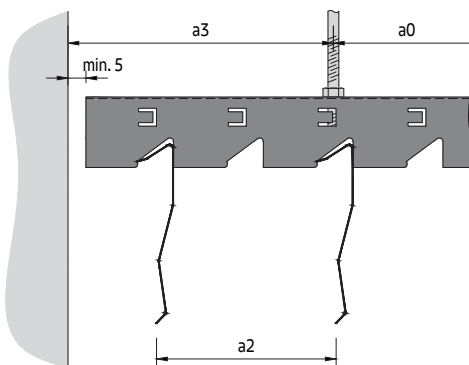

The distance between the carrier and the wall can be freely selected. However, a distance of at least 5 mm should be maintained.

If necessary, use wall anchors to fix the position of the carrier. Where this is not possible, work with angle bracings.

Detail G
Blade to wall

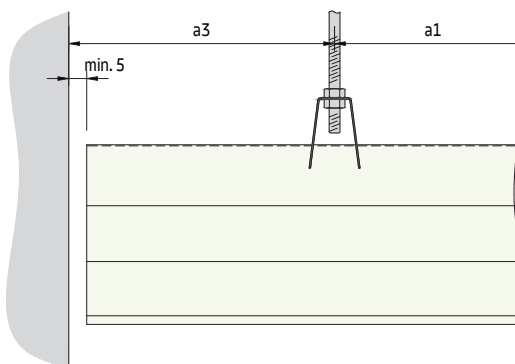

The distance between the blade and the wall can be freely selected. However, a distance of at least 5 mm should be maintained.

Align the blades so that the ends are flush.

Detail H

Baffle insertion

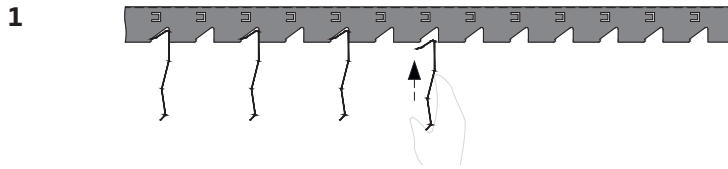

Carefully remove the protective film without damaging the blade. Insert the blade from below.

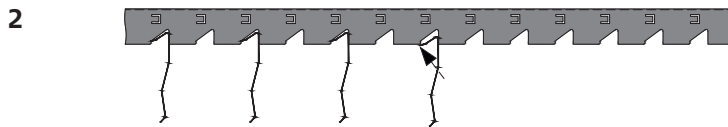

Pull the upper edge upwards until it snaps into place in the carrier. Avoid unnecessary movement in the longitudinal direction of the blades, as the surface may be scratched by the carrier.

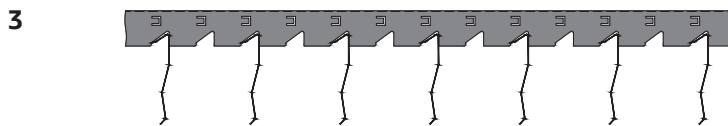

Insert blade after blade.

Baffle extraction

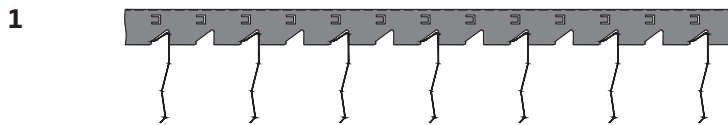

Any blade can be removed as long as there are no obstacles such as service integrations, etc.

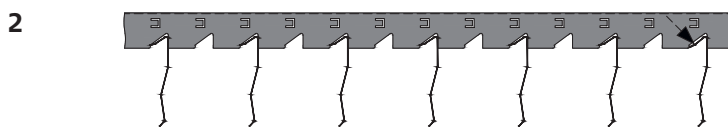

Gently press the upper edge of the blade downwards so that it snaps out of the carrier. Avoid unnecessary movement in the longitudinal direction of the blades, as the surface may be scratched by the carrier.

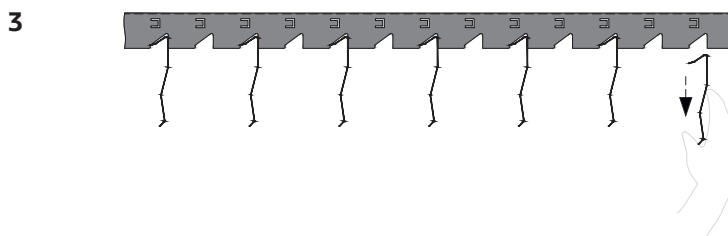

Remove it downwards and store the blade in a safe place so that it cannot be damaged.

METAL Linear Blade
E02.311

Detail I

Connection to columns

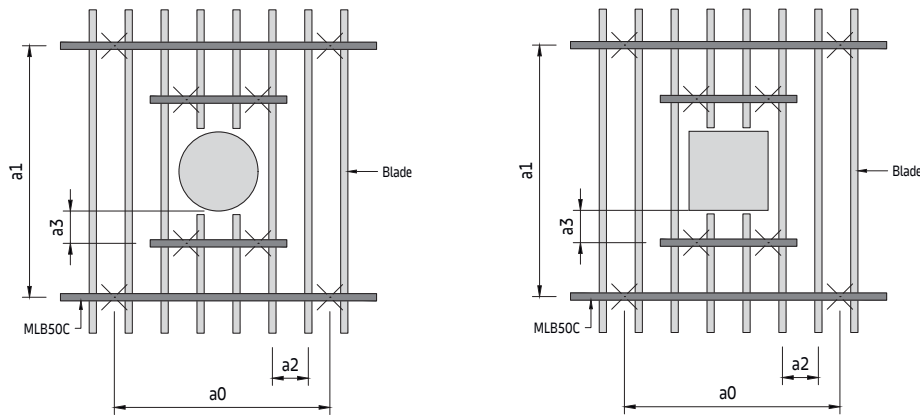

The blades are connected to columns with a minimum distance of 5 mm. There is no provision for fastening the blade. To ensure that the blades are guided and installed safely, additional carriers must be placed on both sides of the column. These should be long enough to run over a continuous blade at both ends.

The distance from the carrier to the column should not exceed (a3).

Service integrations

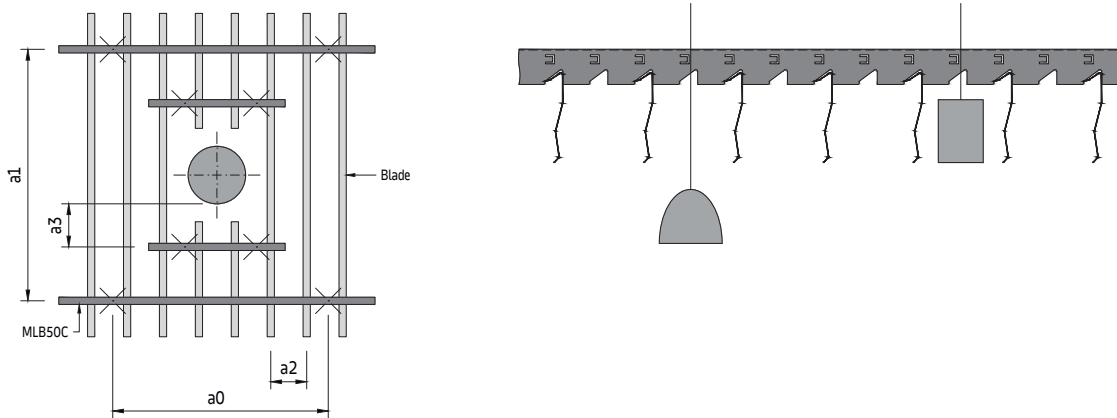

As soon as the service integrations are larger than the distance between the blades, the detail must be solved in the same way as for a column connection.

Smaller service integrations can be suspended between the blades (e.g. pendant lights, signs, etc.) or placed between the blades (the service integration should not touch the blades).

All service integrations must be suspended separately and should not be fixed to the carrier.

Material required per m² (no waste included)**System without additional load [pcs/m²] for overlapping option**

Components		blade spacing (a2) [mm]	100	150	200
MLB50C	Carrier		0.19	0.19	0.19
MLLB50CS	Splice connector for Carrier		0.19	0.19	0.19
Various	Blade 4000 mm (with overlapping (a4) of 100 mm)		10.26	6.84	5.13
M311103	Hexagonal nut M6		0.38	0.38	0.38
M311303	Hexagonal bolt M6 x 16 mm		0.38	0.38	0.38
Various	Suspension points (C1 - C3)		0.64	0.66	0.64

System without additional load [pcs/m²] for gapped option

Components		blade spacing (a2) [mm]	100	150	200
MLB50C	Carrier		0.99	0.99	0.99
MLLB50CS	Splice connector for Carrier		0.99	0.99	0.99
Various	Blade 4000 mm (with gap (a6) of 25 mm)		9.94	6.63	4.97
M311103	Hexagonal nut M6		1.99	1.99	1.99
M311303	Hexagonal bolt M6 x 16 mm		1.99	1.99	1.99
Various	Suspension points (C1 - C3)		0.83	0.83	0.83

The shown quantities are theoretical and based on an ideal layout, without considering the actual room layout. The ideal layout is based on a calculation of 10 x 10 m (100 m²). This calculation does not allow any damage, spare nor wastage. The final quantities and type of suspension have to be checked before ordering. Soffit or wall fixings by others.

General installation sequence

- 1 The position of the suspension points must be marked on the soffit before installation (laser, measuring tape, chalk line, etc.). Then drill the holes and place the top fixing (not offered by Knauf Ceiling Solutions).
- 2 Set threaded rods, Nonius top parts or eye wires, shorten if necessary.
- 3 Wherever possible, fixing should begin on the centre axis of the ceiling area.
- 4 Suspension options:

C1 - Align the height of the carrier and fasten it to the threaded rod with two hexagonal nuts.

C2 - Insert the Nonius hanger into the carrier from above and rotate by 90°. Align the height of the Nonius hanger and fasten it to the Nonius top-part with two safety clips.

C3 - Insert the quick hanger into the carrier from above and rotate by 90°. Align the height of the quick hanger and fasten it to the eye wire.

The minimum installation height is depending on the selected suspension option **C1-C3**.

- 5 Carriers should be aligned with each other in the longitudinal direction and joints should be offset. Couple the carriers with splice connectors.
- 6 Attach blades. Blades can be cut to length on site. Care should be taken not to damage them.
- 7 Service integrations and additional loads must be suspended separately from the soffit. The additional measures must be carried out professionally.



METAL Linear Stripe

Carrier

Semi-exposed grid solution for indoor applications

General information

- Semi-exposed grid system for medium and large rooms
- Typical ceiling weight 2.5 - 4.0 kg/m² (indicative value, without additional load)
- Stripes parallel aligned and made out of pre-coated aluminium
- Stripes are easily installed and fully demountable

Isometric view

Select the suspension option C1 - C2.

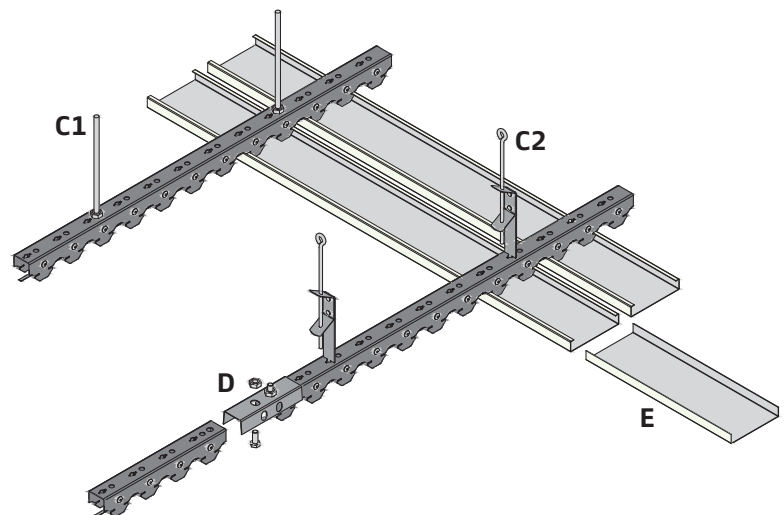

Important information

The carriers must be aligned so that the stripes can be easily attached.

Standard layout options

Single stripe size

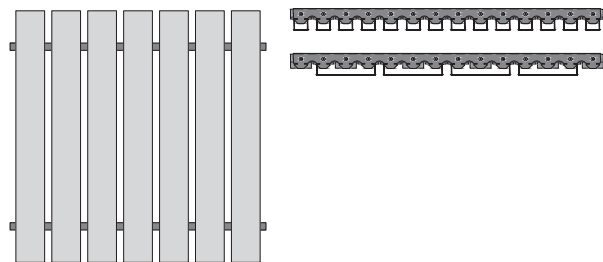

Combined stripe size

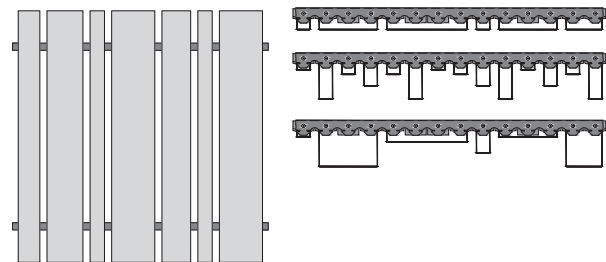

Section A

Example with suspension option C1

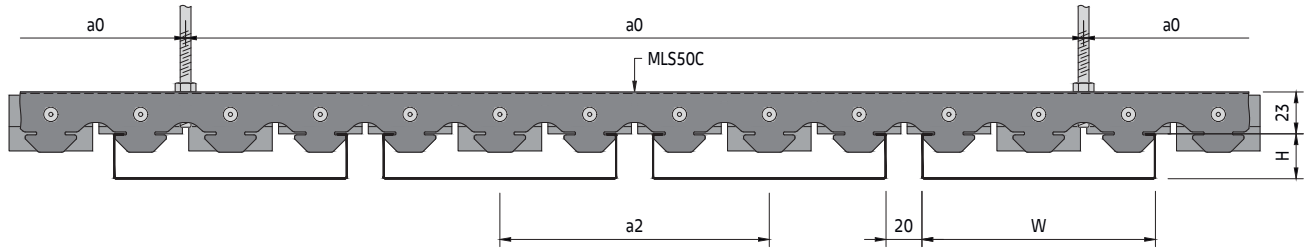

Section B

Example with suspension option C1

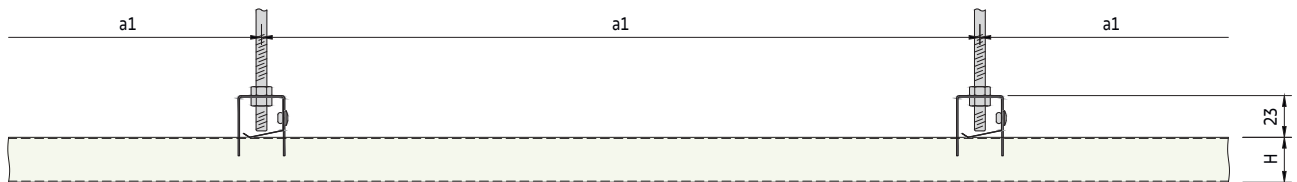

Grid components

Standard components

- MLS50C Carrier
- MLSCS Splice connector for Carrier
- M311103 Hexagonal nut M6
- M311105 Washer
- M3111303 Hexagonal bolt M6 x 16 mm

Suspension option C1

- M311101 Threaded rod M6 x 1000 mm
- M311103 Hexagonal nut M6
- M3111315 Hexagonal extension nut M6 x 30 mm (optional)
- M311061 Suspension element (optional)

Suspension option C2

- MLSQ Quick hanger for Carrier
- - Eye wire (various lengths)

Carrier

MLS50C

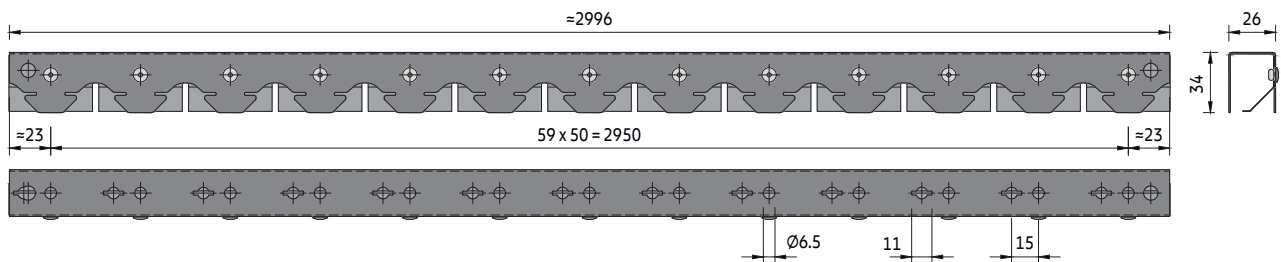

METAL Linear Stripe

E02.312

Typical grid layout (overlapping option)

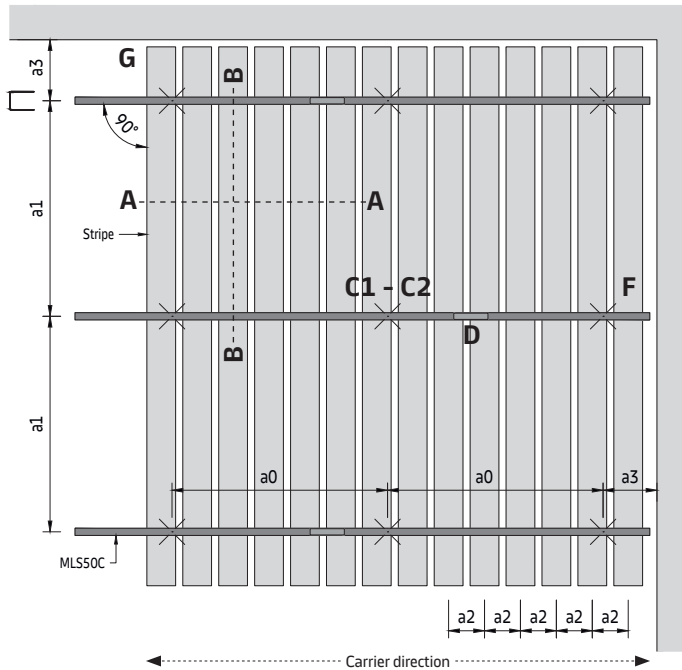

Parameters

- a0 Distance between carrier suspension points = max. 1200 mm
- a1 Max. distance between carriers = max. 1200 mm
- a2 Distance between stripes
- a3 Distance from wall = max. 200 mm
- CM Carrier module length = 3000 mm
- L Stripe length = 3000 mm
- W Stripe width
- H Stripe height

The shown values are maximum allowed distances and can be reduced but not exceeded.

Standard stripe sizes

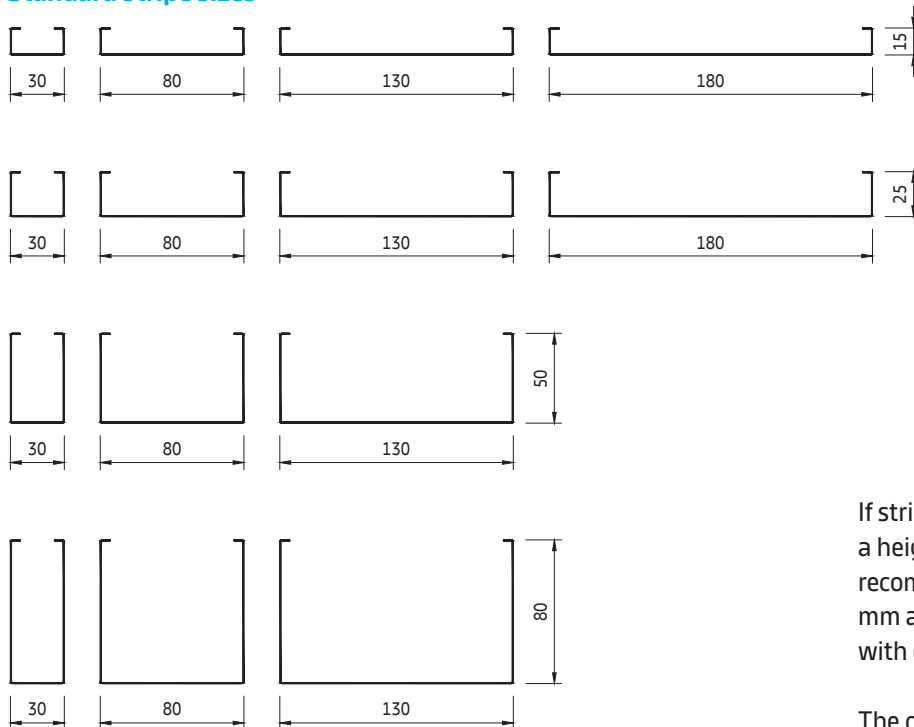

If stripes of the same height are chosen, a height (H) of 15 or 25 mm is recommended. The heights (H) 50 and 80 mm are suitable for layouts where you play with different heights.

The open joint of 20 mm is never changed.

Detail C

Suspension options

Option C1

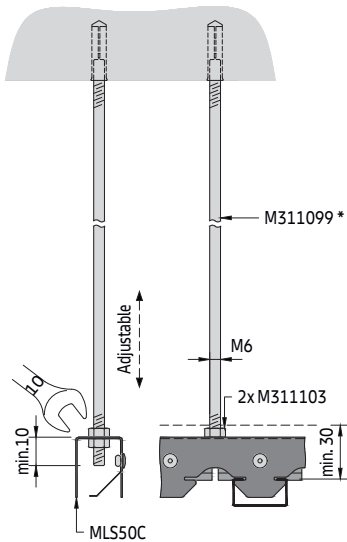

Option C2

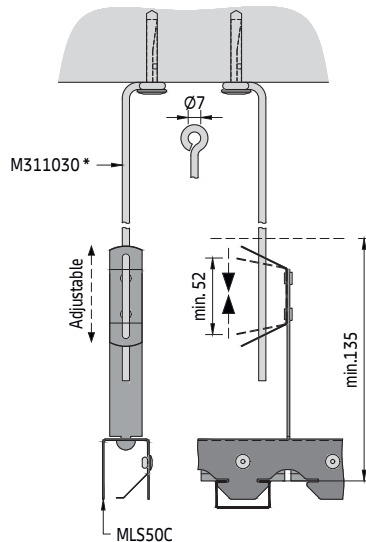

Detail C3

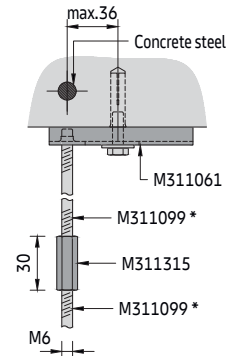

Make sure that the suspension points are set precisely. This will make the installation of the stripes much easier. The quick hanger (C2) is inserted into the carrier from above and rotated by 90°. The clip (C2) should only be compressed as indicated to avoid possible damage.

Optional top fixing and extension detail for suspension option C1

* Various lengths available

Detail D

Carrier splice connection

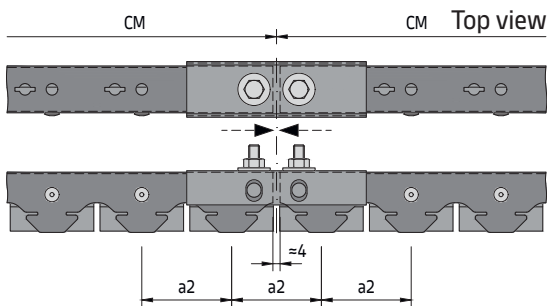

The splice connector is placed between the two ends of the carriers. Use two M6 bolts, nuts and washers to fix it. The carriers are manufactured shorter so that a gap is created between the carriers when installed. This ensures that the spacing (a2) is continued. The position of the suspension points must not be on a connection. Keep this in mind when planning.

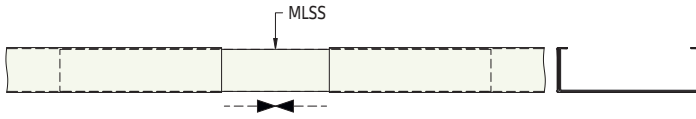
Detail E**Stripe splice connection**

In order to obtain a more stable and straight alignment, stripes are coupled at the carrier using a splice connector.

Splice connector length = 240 mm

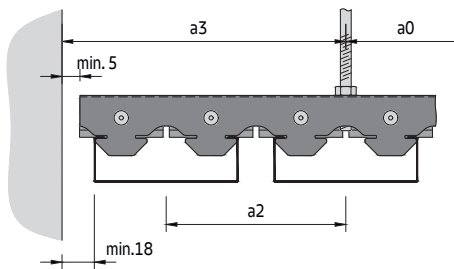
Detail F**Carrier to wall**

The distance between the carrier and the wall can be freely selected. However, a distance of at least 5 mm should be maintained.

If necessary, use wall anchors to fix the position of the carrier. Where this is not possible, work with angle bracings.

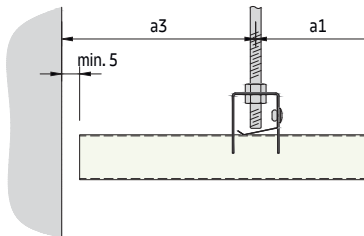
Detail G**Stripe to wall**

The distance between the stripe and the wall can be freely selected. However, a distance of at least 5 mm should be maintained.

Align the stripes so that the ends are flush.

Detail H

Stripe insertion

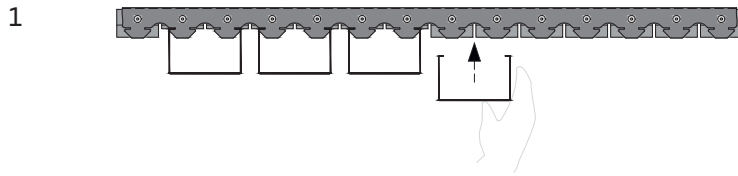

Carefully remove the protective film without damaging the stripe. Insert the stripe from below.

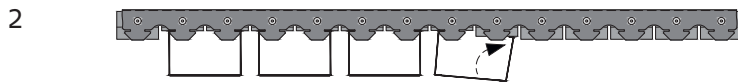

Insert the stripe on one edge. The springs of the carrier are pushed upwards so that the stripes are held in position.

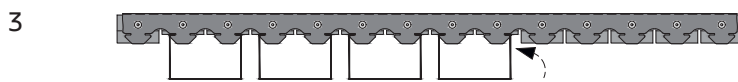

Carefully pull the opposite edge upwards.

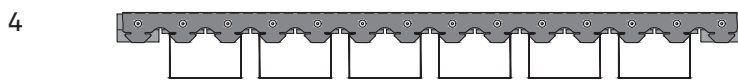

Carefully pull the opposite edge upwards.

Stripe extraction

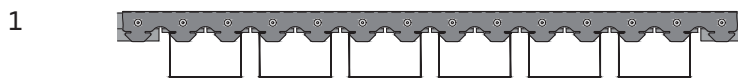

Any stripe can be removed as long as there are no obstacles such as service integrations, etc.

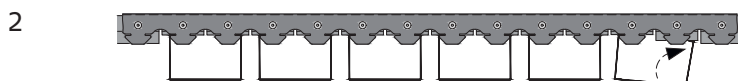

Pull on the edge carefully so that the stripe can be removed.

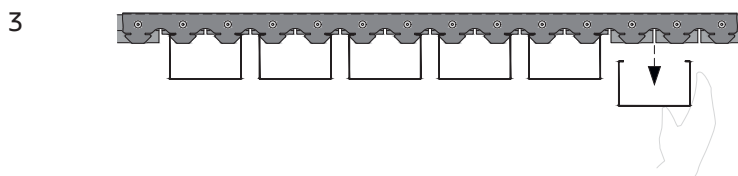

Remove it downwards and store the stripe in a safe place so that it cannot be damaged.

Detail I

Connection to columns

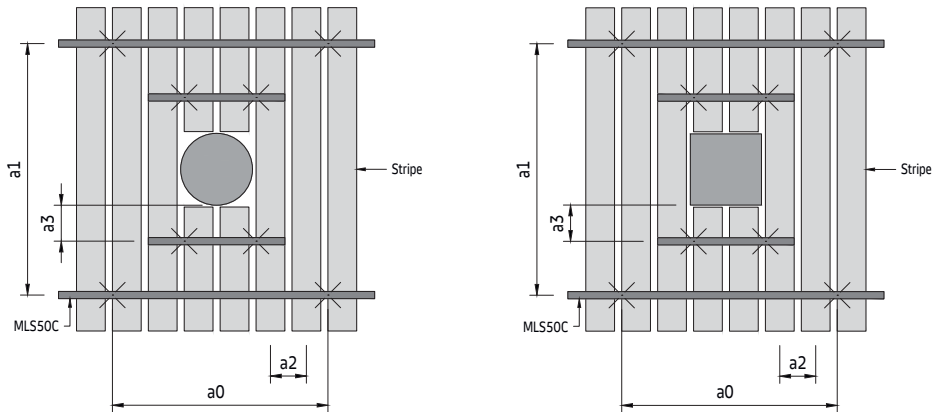

The stripes are connected to columns with a minimum distance of 5 mm. There is no provision for fastening the stripe. To ensure that the stripes are guided and installed safely, additional carriers must be placed on both sides of the column. These should be long enough to run over a continuous stripe at both ends.

The distance from the carrier to the column should not exceed (a3).
The stripe ends can be cut either straight or along the desired contour.

Service integrations

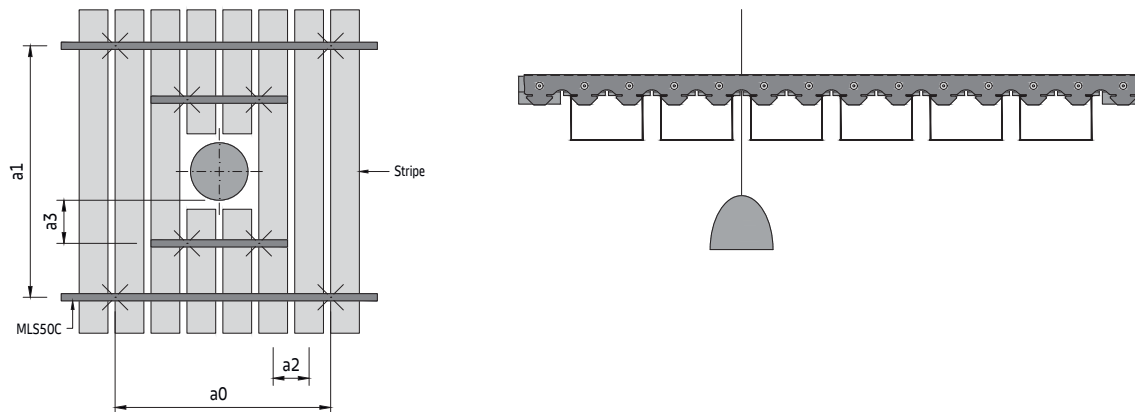

As soon as the service integrations are larger than the distance between the stripes, the detail must be solved in the same way as for a column connection.

Smaller service integrations can be suspended between the stripes (e.g. pendant lights, signs, etc.) or placed between the stripes (the service integration should not touch the stripes). All service integrations must be suspended separately and should not be fixed to the carrier.

METAL Linear Stripe

E02.312

Material required per m² (no waste included)**System without additional load [pcs/m²]**

Components	stripe width (W) [mm]	30	80	130	180
MLS50C	Carrier	0.28	0.28	0.28	0.28
MLSCS	Splice connector for Carrier	0.28	0.28	0.28	0.28
Various	Stripe (various heights)	6.67	3.33	2.22	1.67
Various	Splice connector for stripe	6.67	3.33	2.22	1.67
M311103	Hexagonal nut M6	0.56	0.56	0.56	0.56
M311105	Washer	0.56	0.56	0.56	0.56
M311303	Hexagonal bolt M6 x 16 mm	0.56	0.56	0.56	0.56
Various	Suspension points (C1 - C2)	0.69	0.69	0.69	0.69

The shown quantities are theoretical and based on an ideal layout, without considering the actual room layout. The ideal layout is based on a calculation of 10 x 10 m (100 m²). This calculation does not allow any damage, spare nor wastage. The final quantities and type of suspension have to be checked before ordering. Soffit or wall fixings by others. Not including baffle end caps.

General installation sequence

- 1 The position of the suspension points must be marked on the soffit before installation (laser, measuring tape, chalk line, etc.). Then drill the holes and place the top fixing (not offered by Knauf Ceiling Solutions).
- 2 Set threaded rods or eye wires, shorten if necessary.
- 3 Wherever possible, fixing should begin on the centre axis of the ceiling area.
- 4 Suspension options:

C1 - Align the height of the carrier and fasten it to the threaded rod with two hexagonal nuts.

C2 - Insert the quick hanger into the carrier from above and rotate by 90°. Align the height of the quick hanger and fasten it to the eye wire.

The minimum installation height is depending on the selected suspension option **C1-C2**.

- 5 Carriers should be aligned with each other in the longitudinal direction and joints should be offset. Couple the carriers with splice connectors.
- 6 Attach stripes and couple them with splice connectors. Stripes can be cut to length on site. Care should be taken not to damage them.
- 7 Service integrations and additional loads must be suspended separately from the soffit. The additional measures must be carried out professionally.



METAL Wallcoustic Horizon 1000
KLM Training Centre, Schiphol, Netherlands
© EISMA

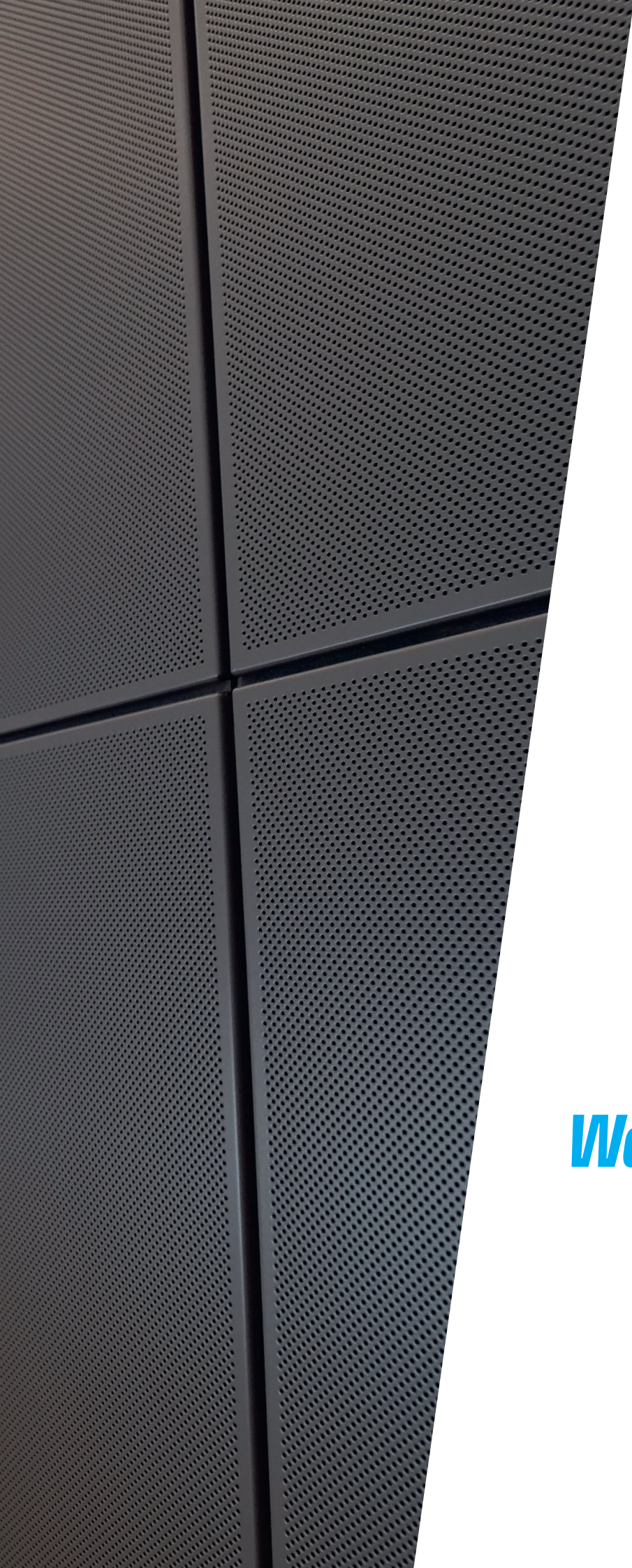

Wall Solutions

METAL Wallcoustic Horizon 1000

C-Wall Profile grid

Concealed wall solution for indoor applications

General information

- Concealed hook-on grid system for walls
- C-Wall Profile made of galvanised steel
- Typical ceiling weight up to 10.5 kg/m² (indicative value for unperforated panels, without additional load)
- Upright or reclined layout
- Panels are easily installed and fully demountable
- Acoustic & design solution
- Various panel types for corner, end and transition details available on request

Isometric view

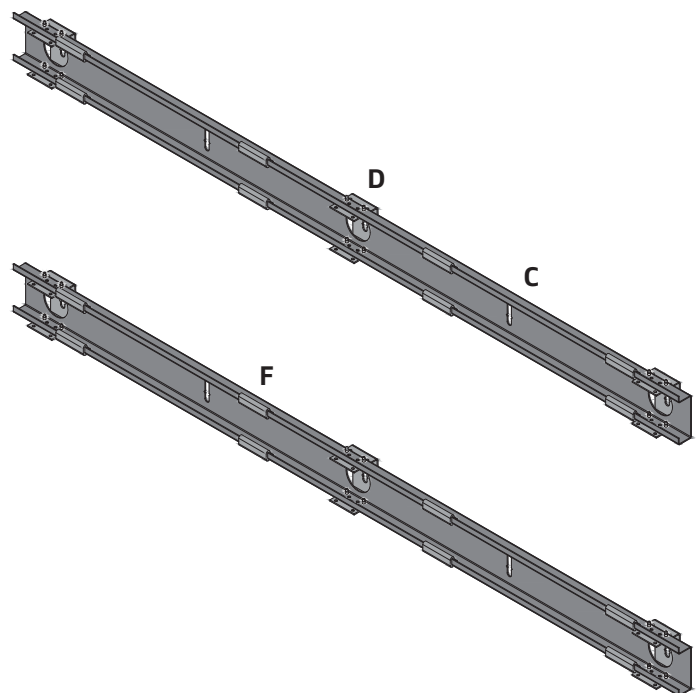

Vario Design layout options

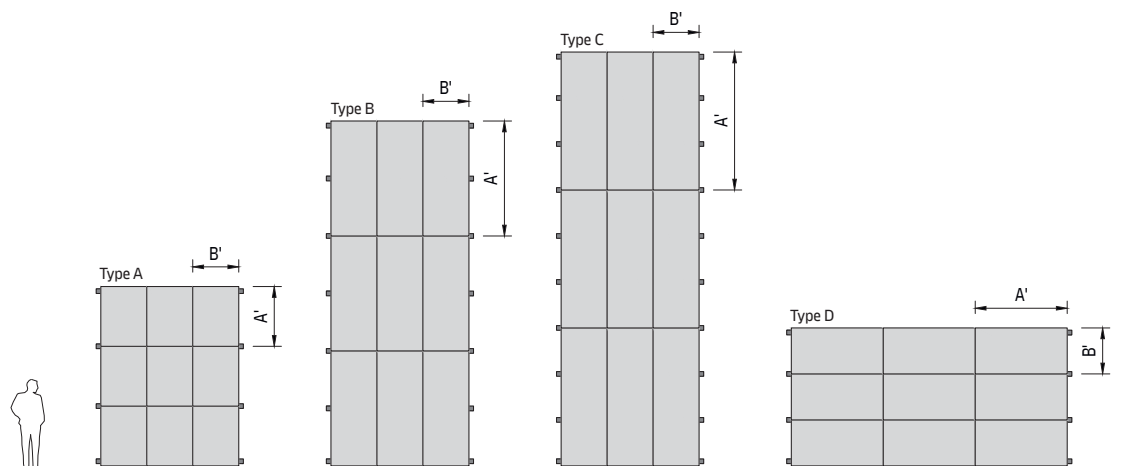

METAL Wallcoustic Horizon 1000

F02.100

Section A
Horizontal section

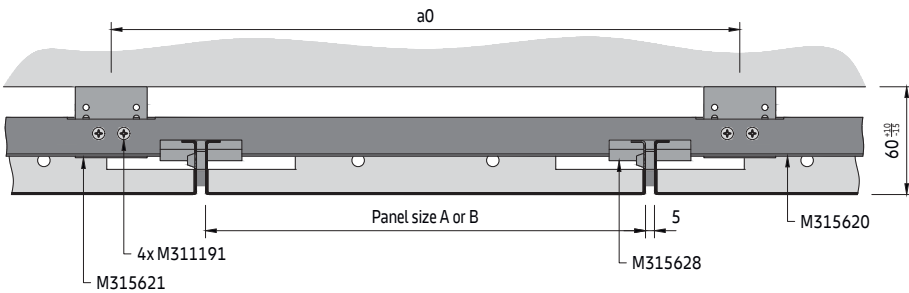

Section A
Vertical section

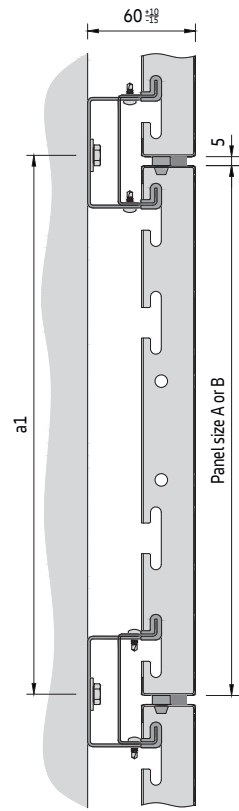

Panel dimensions

- Type A A' = 600 - 1300, B' = 250 - 1000 mm, with 2 suspension points per long side
- Type B A' = 600 - 2500, B' = 250 - 1000 mm, with 3 suspension points per long side
- Type C A' = 600 - 3000, B' = 250 - 1000 mm, with 4 suspension points per long side
- Type D A' = 600 - 2000, B' = 250 - 1000 mm, with 2 suspension points per short side

Important informations

The panels are not designed for impact resistance. This is a pure acoustic and design solution. The panels must be made to measure and cannot be cut to size on site. The longer the upright installed panels are, the more suspension points are needed (type A, B, C).

The panels come standard with a 5 mm gasket and spacers on the long and short side, which simplifies installation and improves visual appearance. An option without gasket and spacers is not offered.

For a professional execution, CAD details are recommended (layouts, elevations, details).

Components

Standard components

- M315620 C-Wall Profile
- M315629 Splice connector for C-Wall Profile
- M315621 Wall anchor for C-Wall Profile
- M315628 Supporting bracket
- M311191 Self-drilling screw 3.5 x 9.5 mm

C-Wall Profile

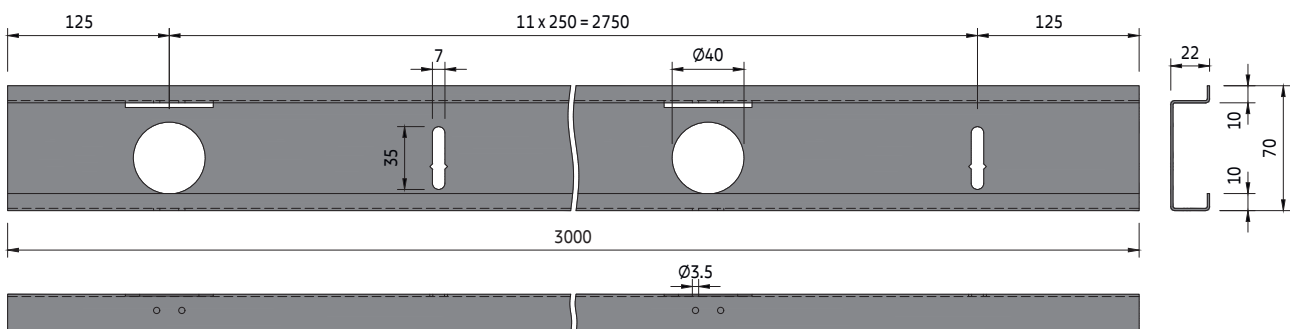

METAL Wallcoustic Horizon 1000

F02.100

Parameters

- a0 Distance between wall fixing points = 500 mm
- a1 Distance between C-Wall Profile = max. 1300 mm
- a2 Distance from C-Wall Profile end to wall fixing point = max. 375 mm
- A' Module length = panel length (A) + 5 mm
- B' Module width = panel width (B) + 5 mm

Typical grid layout

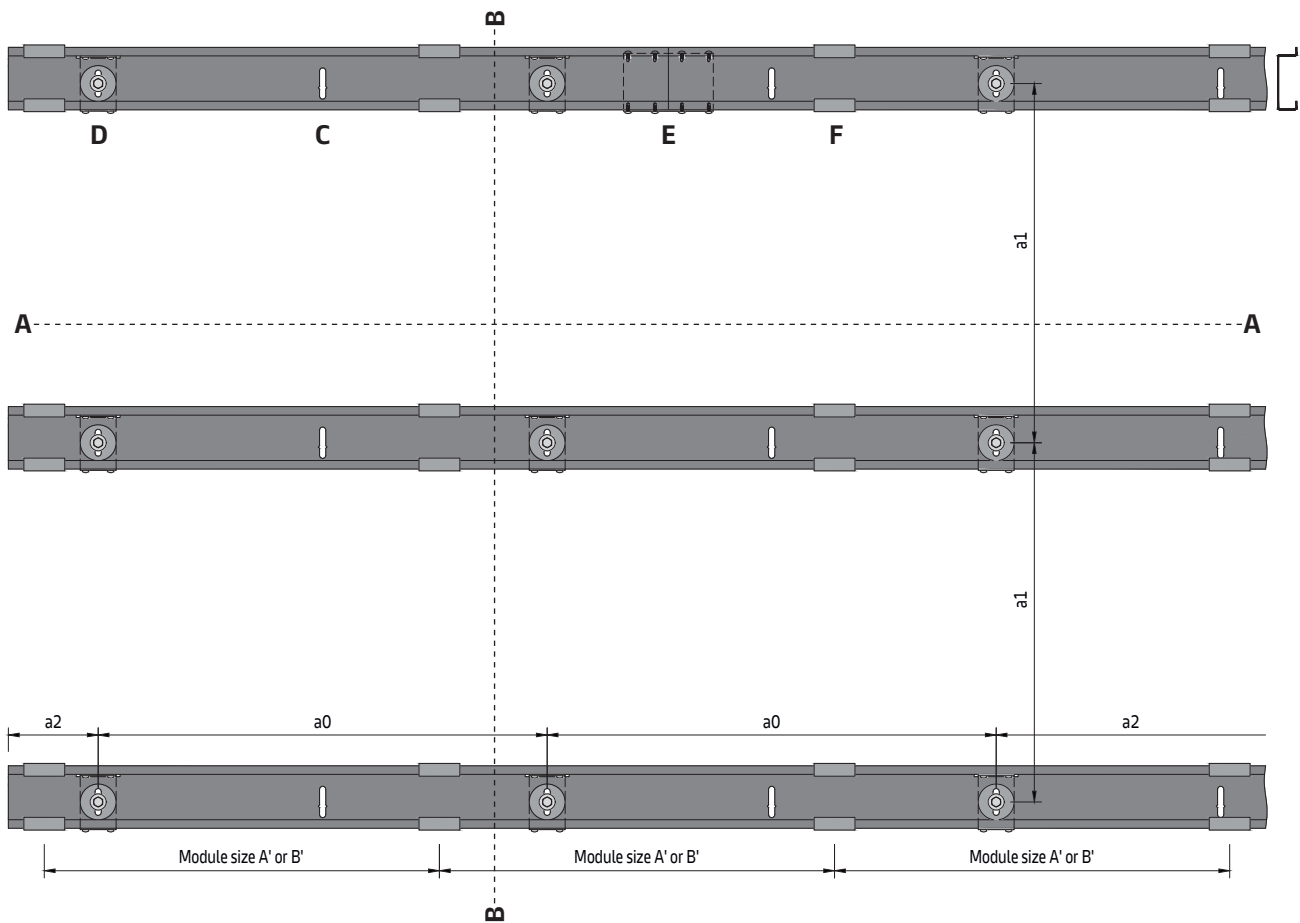

Detail C

Direct fixing option

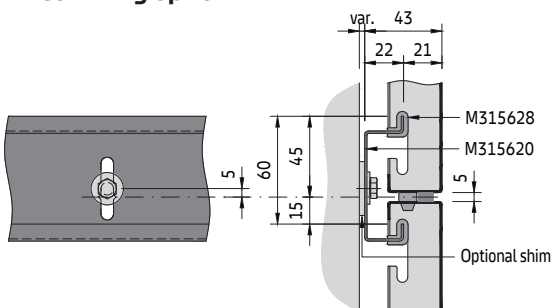

It is recommended to use the wall anchors for fixing to the wall as described in detail D. Optionally, the C-Wall Profile can be attached directly to the wall.

Position the C-Wall Profile on the wall and fix it (wall fixing min. 1 kN). Markings are stamped in the long hole. The lower one is on the central axis of the panel joint. The center of the long hole is 5 mm above it.

Fix the C-Wall Profile at a distance of a0. Level out the unevenness of the wall with shims.

METAL Wallcoustic Horizon 1000
F02.100

Detail D
Wall anchor installation

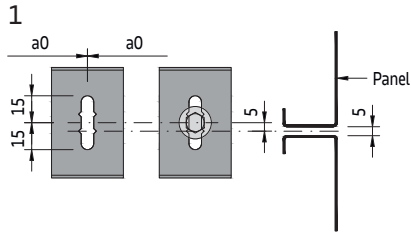

Position the wall anchor on the wall and fix it (wall fixing min. 1 kN). Markings are stamped in the long hole. The lower one is on the central axis of the panel joint. The center of the long hole is 5 mm above it. Lay the wall anchor at a distance of a0.

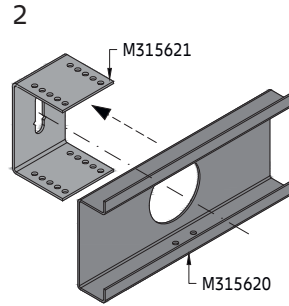

Guide the wall anchor through the slot in the C-Wall Profile.

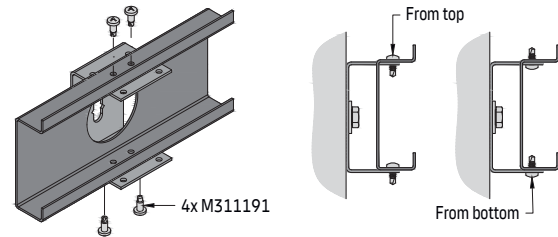
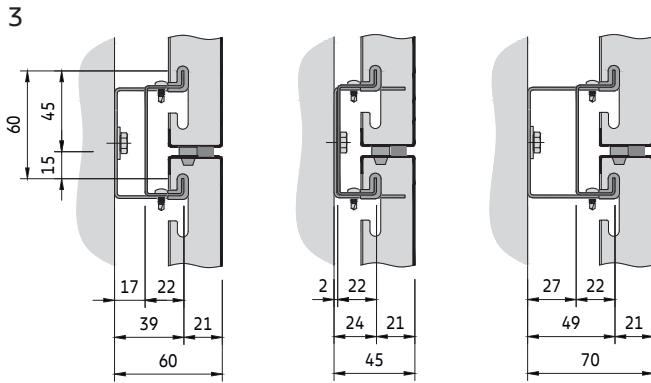

Align the depth of the profile and fix it with four self-drilling screws. The standard offset is 60 mm. The self-drilling screws can be screwed in either from above or from below, depending on the space available.

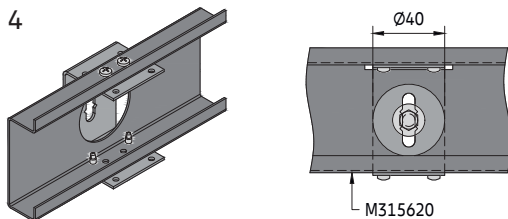

The C-Wall Profile has Ø40 mm round holes. The wall fixings can be loosened a bit so that the height of the profile can be corrected without having to dismantle everything.

Detail F
Supporting bracket

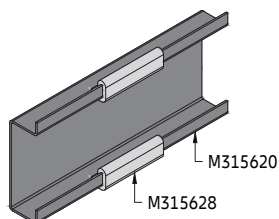

The panels are placed on supporting brackets M315628 made of rubber. As a result, the panels cannot easily shift and remain in position. There is also no noise in the event of any vibrations.

Detail E
Splice connection

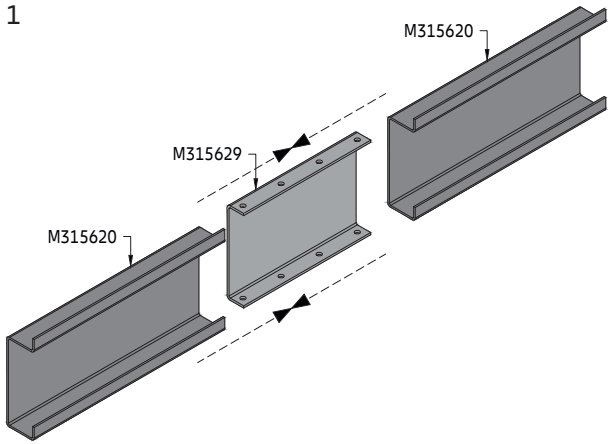

The ends of the C-Wall Profiles should be butt together without a gap.

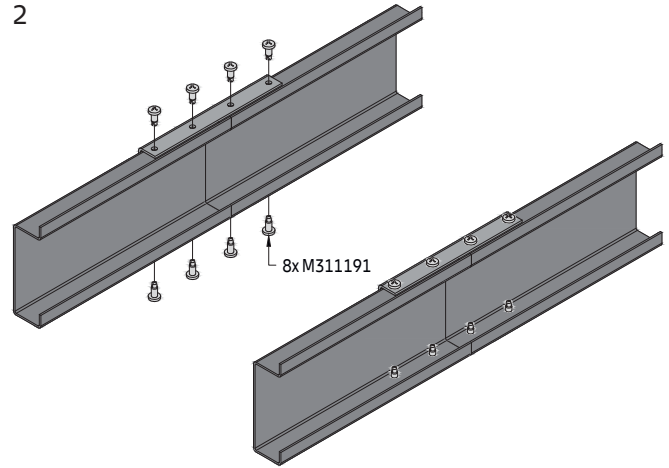

Use the self-drilling screws to fix it together.

Detail G
Top and bottom end panels

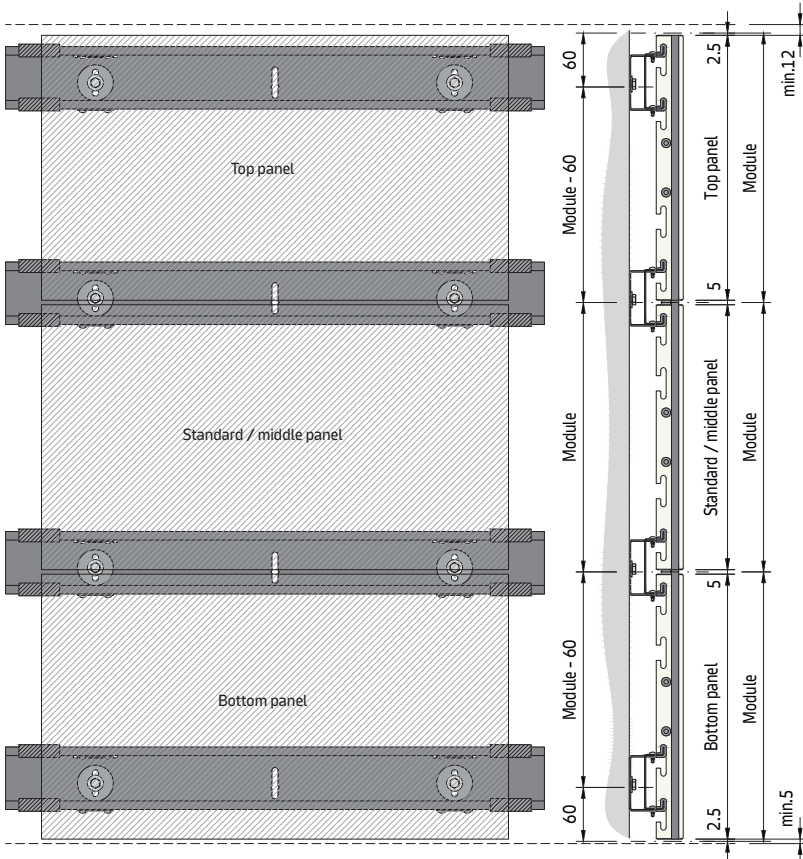

For the top and bottom panels, the C-Wall Profile can be moved inwards by 60 mm so that it is no longer visible. This is possible because the panels have a double notching.

In order to be able to hook-on the panels, a minimum distance of 12 mm is required at the top.

A minimum clearance of 5 mm is recommended at the bottom and vertical sides.

Detail H

Panel insertion

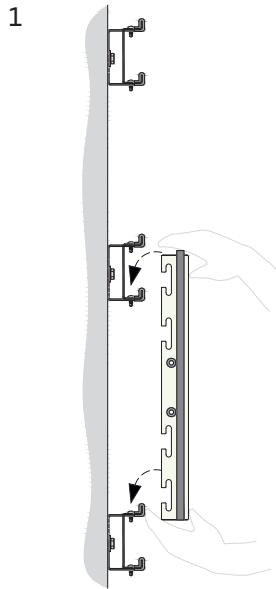

When installing the panels, start with the bottom row first.

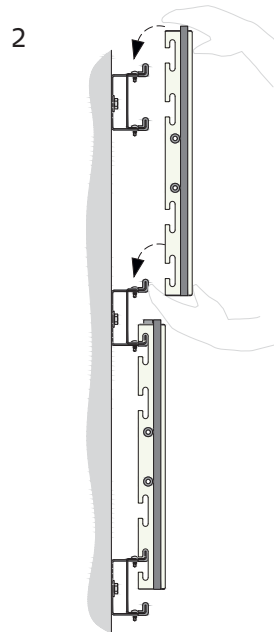

Follow with the next one up until the top row is reached.

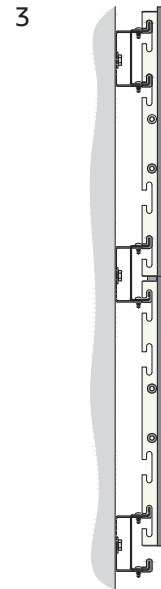

Gently press the panels down until the joint is 5 mm. The spacers ensure that the joint width is not exceeded.

Panel extraction

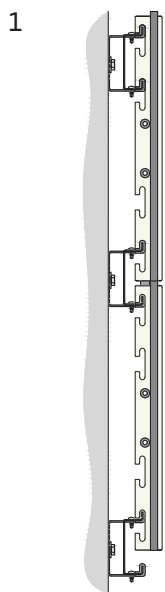

The panels are removed in the reverse order of installation from top to bottom.

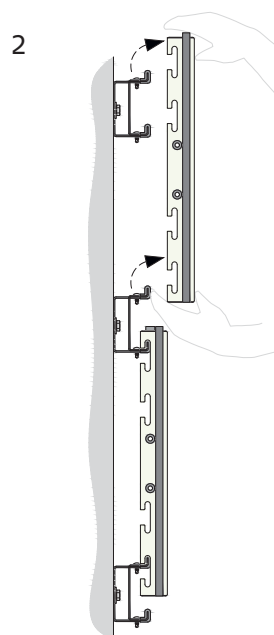

Start with the top panel first.

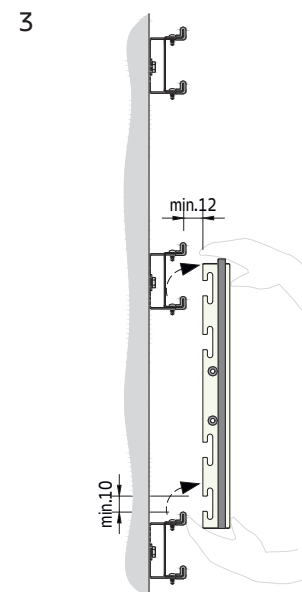

Lift up the panel by min. 10 mm and move it away from the wall by min. 12 mm. Store the panel in a safe place so that it cannot be damaged.

METAL Wallcoustic Horizon 1100

Wall hanging kit

Single wall absorber solution for indoor application

General information

- Concealed hook-on grid system for walls
- U-Wall Profile made of galvanised steel
- Typical ceiling weight up to 10.5 kg/m² (indicative value for unperforated panels, without additional load)
- Upright or reclined layout
- Panels can be removed
- Acoustic & design solution
- Various panel types for corner, end and transition details available on request

Isometric view

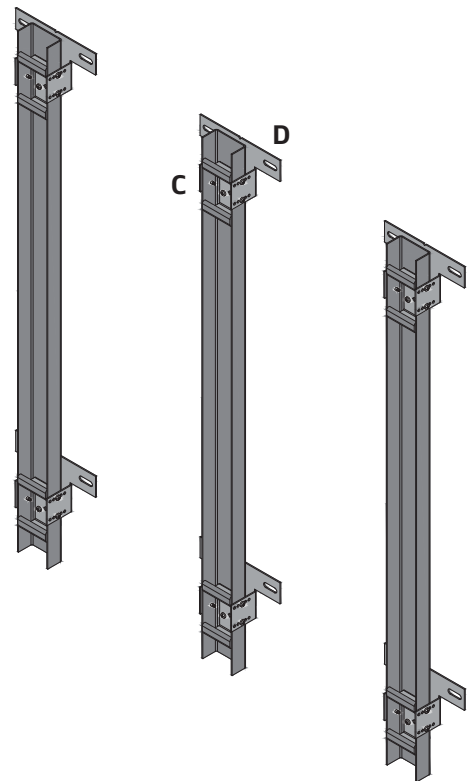

Vario Design layout options

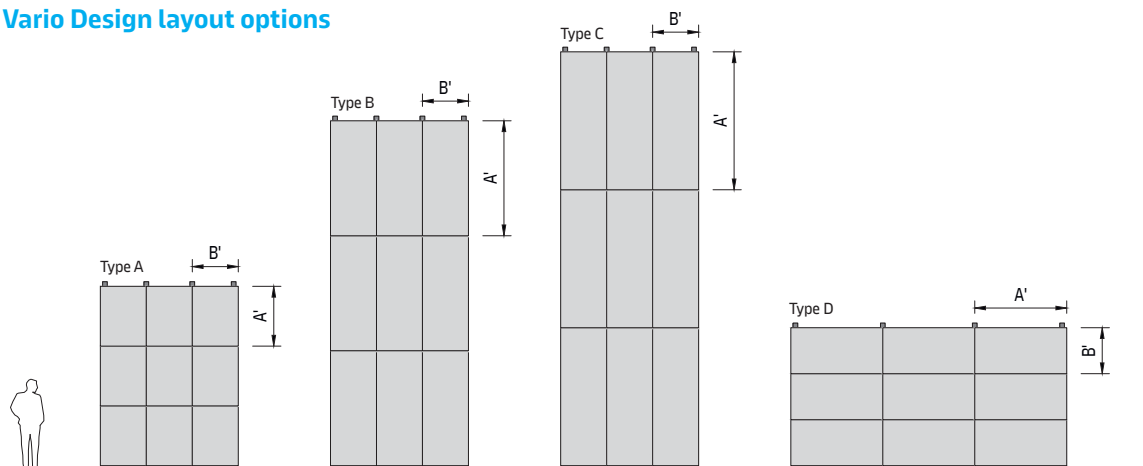

METAL Wallcoustic Horizon 1100

F02.101

Section A Horizontal section

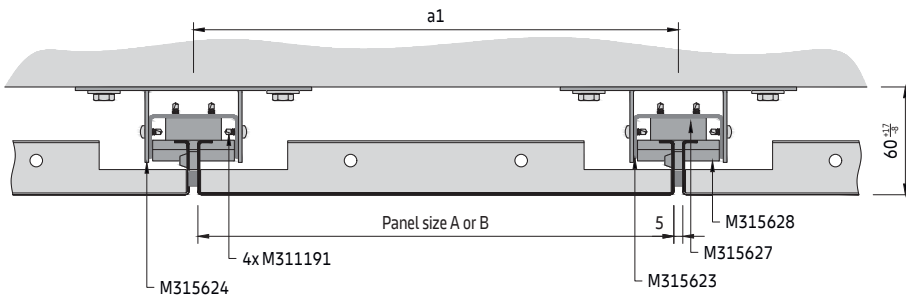

Panel dimensions

- Type A A' = 600 - 1300, B' = 250 - 1000 mm, with 2 suspension points per long side
- Type B A' = 600 - 2500, B' = 250 - 1000 mm, with 3 suspension points per long side
- Type C A' = 600 - 3000, B' = 250 - 1000 mm, with 4 suspension points per long side
- Type D A' = 600 - 2000, B' = 250 - 1000 mm, with 2 suspension points per short side

Important informations

The panels are not designed for impact resistance. This is a pure acoustic and design solution. The panels must be made to measure and cannot be cut to size on site. The longer the upright installed panels are, the more suspension points are needed (type A, B, C). The panels come standard with a 5 mm gasket and spacers on the long and short side, which simplifies installation and improves visual appearance. An option without gasket and spacers is not offered. For a professional execution, CAD details are recommended (layouts, elevations, details).

Section A Vertical section

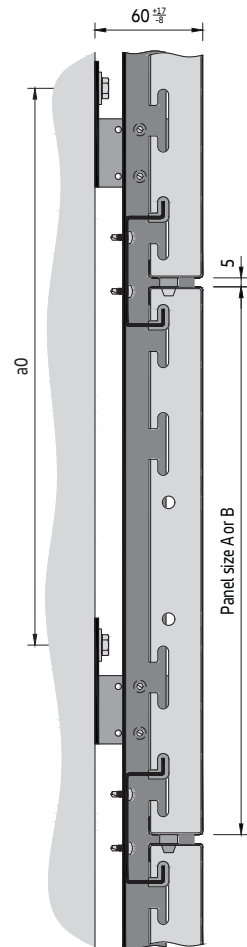

Components

Standard components

- | | | | |
|-----------|-------------------------------------|-----------|---------------------------------------|
| ▪ M315623 | U-Wall Profile | ▪ M315625 | Corner wall anchor for U-Wall Profile |
| ▪ M315626 | Splice connector for U-Wall Profile | ▪ M315627 | Suspension element for U-Wall Profile |
| ▪ M315624 | Wall anchor for U-Wall Profile | ▪ M315628 | Supporting bracket |
| | | ▪ M311191 | Self-drilling screw 3.5 x 9.5 mm |

U-Wall Profile

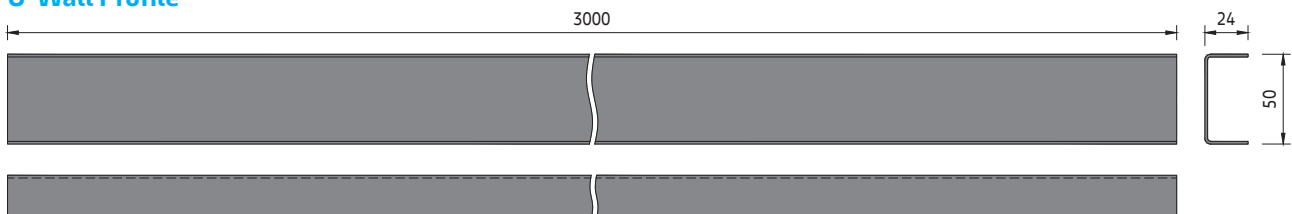

METAL Wallcoustic Horizon 1100

F02.101

Parameters

- a0 Distance between wall fixing points for type A, B, C = max.750 mm, for type D = max.500 mm
- a1 Distance between U-Wall Profile for type A, B, C = max.1000 mm, for type D = max.2000 mm
- a2 Distance from U-Wall Profile end to wall fixing point = max.100 mm
- a3 Distance between panel suspension points
- A' Module length = panel length (A) + 5 mm
- B' Module width = panel width (B) + 5 mm

Typical grid layout

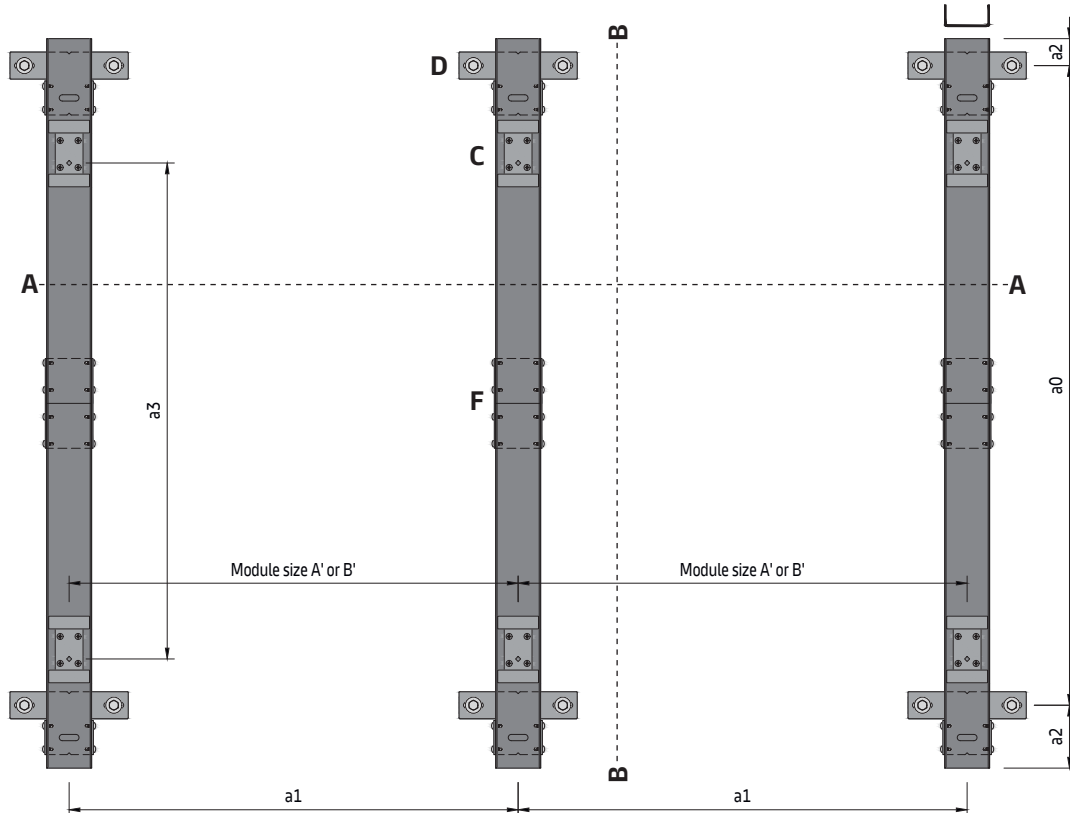

Detail C

Suspension element

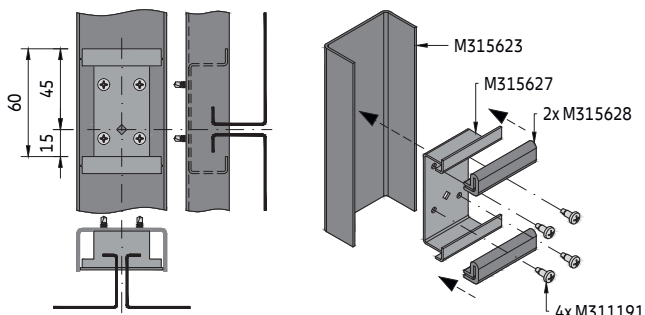

The suspension element has a square stamping that depicts the central axis of the horizontal and vertical panel joints.

Use four self-drilling screws to attach it to the C-Wall Profile.

The panels are placed on supporting brackets M315628 made of rubber. As a result, the panels cannot easily shift and remain in position. There is also no noise in the event of any vibrations.

METAL Wallcoustic Horizon 1100

F02.101

Detail D

Wall anchor installation

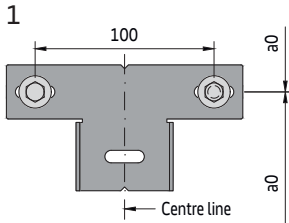

Position the wall anchor on the wall and fix it (wall fixing min. 1 kN). Markings are stamped on top and bottom of the wall anchor, indicating the centre line. Install the wall anchor at a distance of a0.

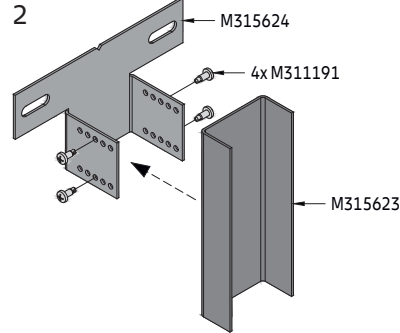

Align the depth of the profile and fix it with four self-drilling screws. The standard offset is 60 mm.

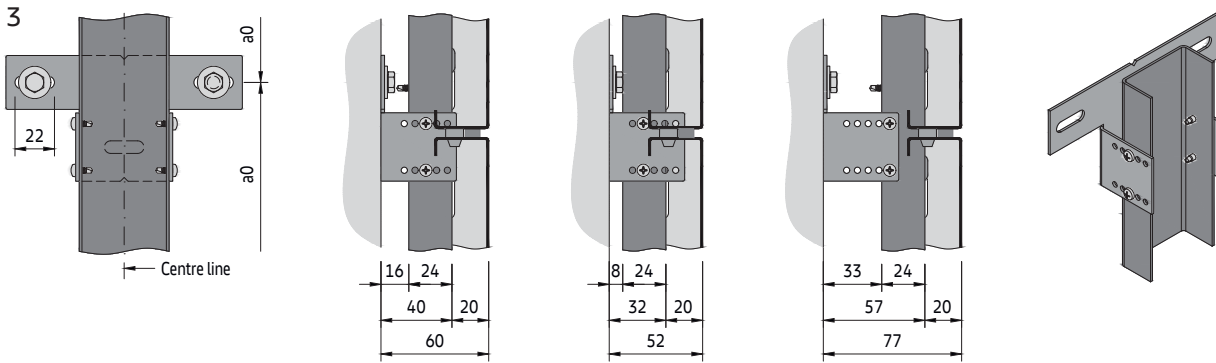

The wall anchor has 22 mm long holes. This allows the wall fixings to be loosened slightly so that the wall anchor and U-Wall Profile can be adjusted ≈ 7 mm to the left or right if necessary, without having to dismantle everything.

Detail E

Corner wall anchor installation

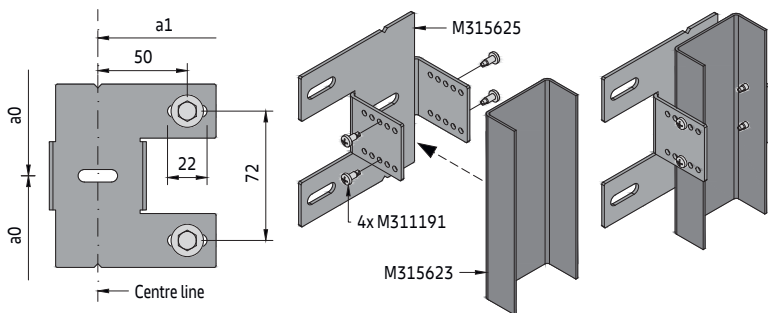

Installation is the same as explained in Detail D.

The only difference is that the wall fixings are on top of each other. This allows installation where the standard wall anchor cannot be installed. The corner wall anchor can be installed pointing left or right.

Custom panel solutions for inside and outside corners are available upon request.

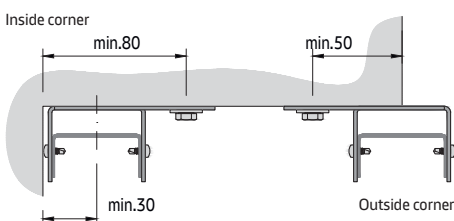

Inside corner: The corner wall anchors are first assembled with the U-Wall profile and then everything is attached to the wall together. In this way, a minimum distance of 30 mm can be achieved.

Outside corner: It must be ensured that a minimum distance of 50 mm is maintained between the wall fixing point and the corner

METAL Wallcoustic Horizon 1100

F02.101

Detail F
Splice connection

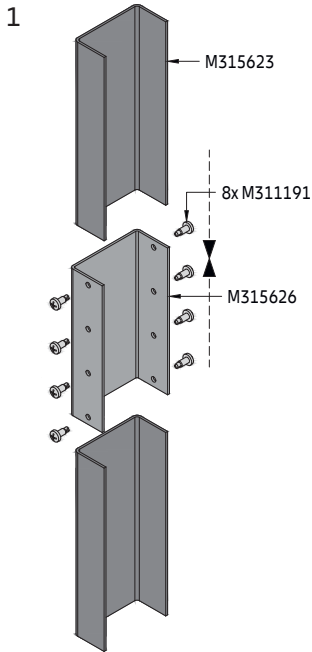

The ends of the U-Wall Profiles should be butt together without a gap.

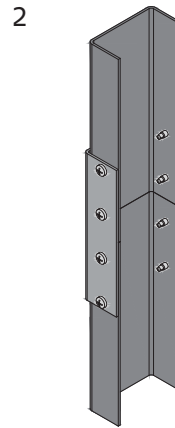

Use the self-drilling screws to fix it together.

Detail G
Top and bottom end panels

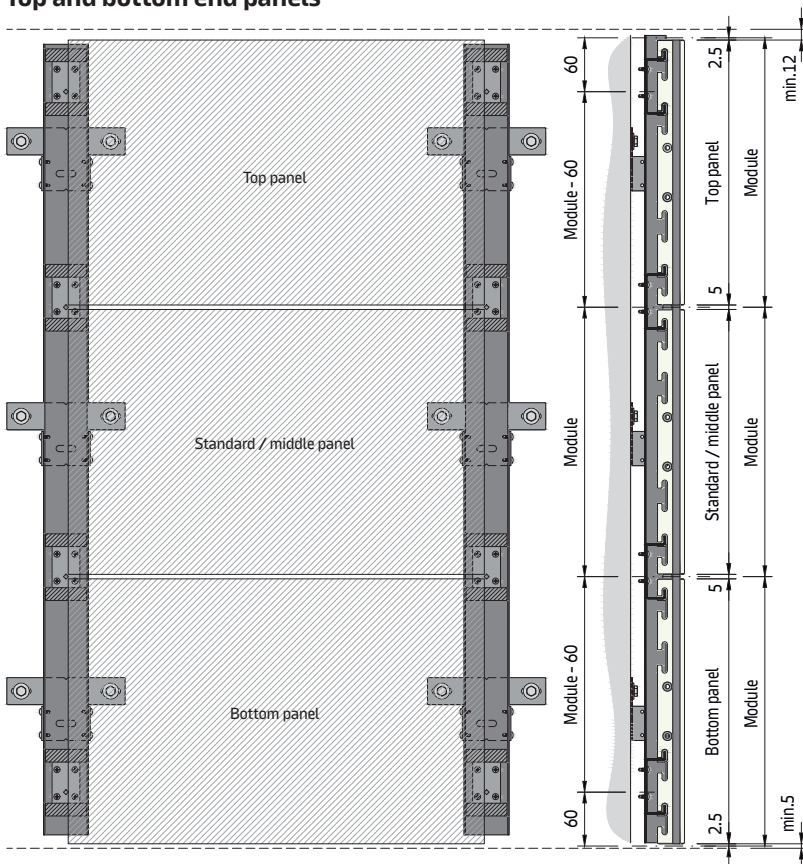

For the top and bottom panels, the suspension element for U-Wall Profile can be moved inwards by 60 mm so that it is no longer visible. This is possible because the panels have a double notching.

In order to be able to hook-on the panels, a minimum distance of 12 mm is required at the top.

A minimum clearance of 5 mm is recommended at the bottom and vertical sides.

METAL Wallcoustic Horizon 1100

F02.101

Detail H

Panel type D reinforcement option

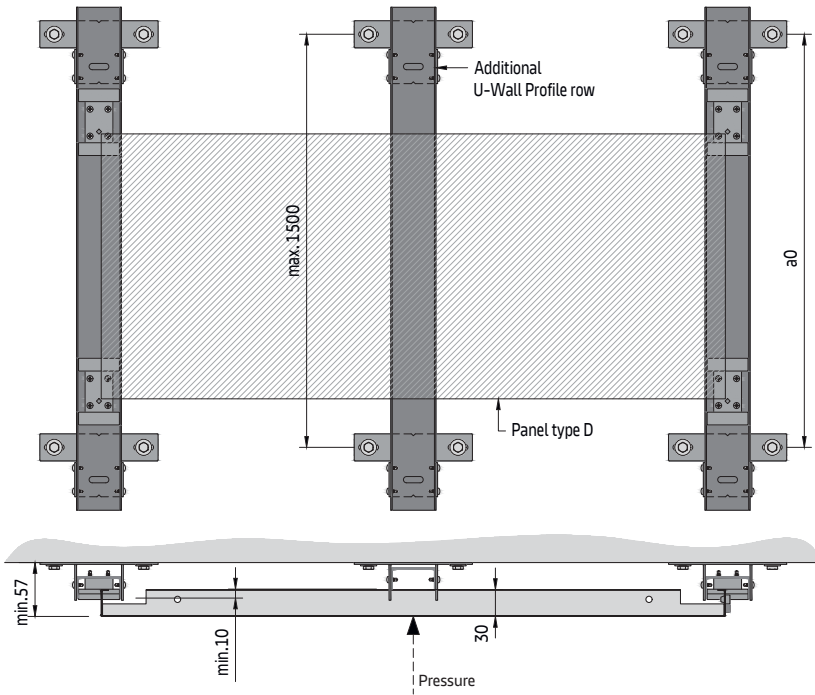

Optionally, an additional U-Wall Profile can be placed in between. This prevents deformation of longer reclined panels. The U-Wall Profile is aligned 10 mm further back. Since there is no load on the profile, it can be fixed to the wall at a distance of up to 1500 mm. This option requires a minimum offset of 57 mm.

Detail I

Panel insertion

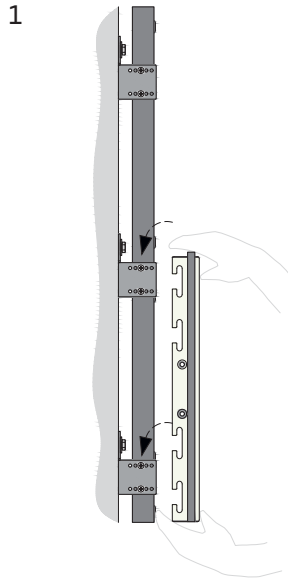

When installing the panels, start with the bottom row first.

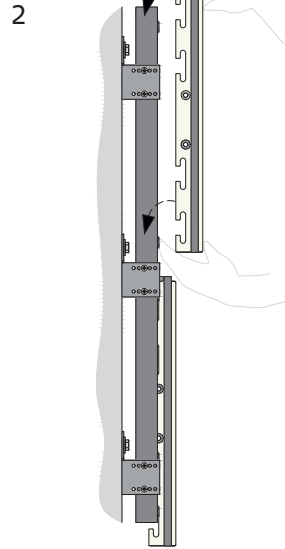

Follow with the next one up until the top row is reached.

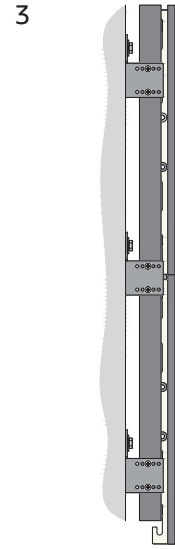

Gently press the panels down until the joint is 5 mm. The spacers ensure that the joint width is not exceeded.

Panel extraction

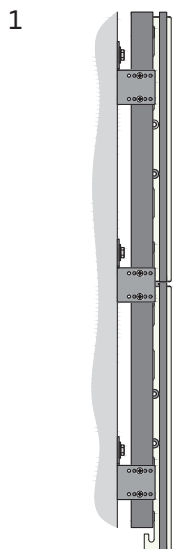

The panels are removed in the reverse order of installation from top to bottom.

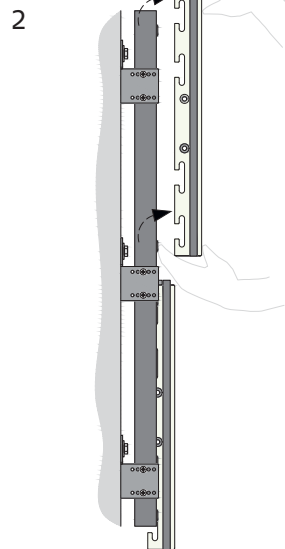

Start with the top panel first.

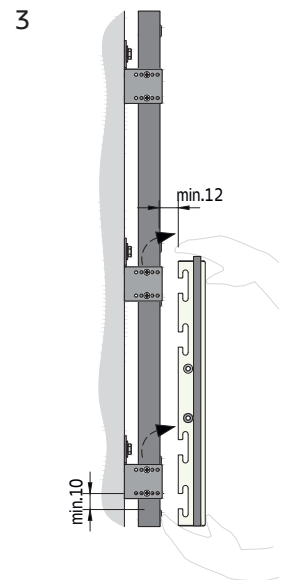

Lift up the panel by min. 10 mm and move it away from the wall by min. 12 mm. Store the panel in a safe place so that it cannot be damaged.



METAL Wallcoustic Horizon 1000
Wirral Waters, Tower Wharf, United Kingdom
© Infinite 3D Limited

METAL Wallcoustic Element

Wall hanging kit

Single wall absorber solution for indoor application

General information

- Wall hanging kit for wall absorbers
- For upright or reclined installation
- Optional acoustic pad and rear cover (factory fixed by pop-rivets)
- Typical wall absorber weight 4.3 - 26.0 kg/m² (indicative value for unperforated panels, without additional load)
- Panels can be removed
- Acoustic & design elements

Isometric view

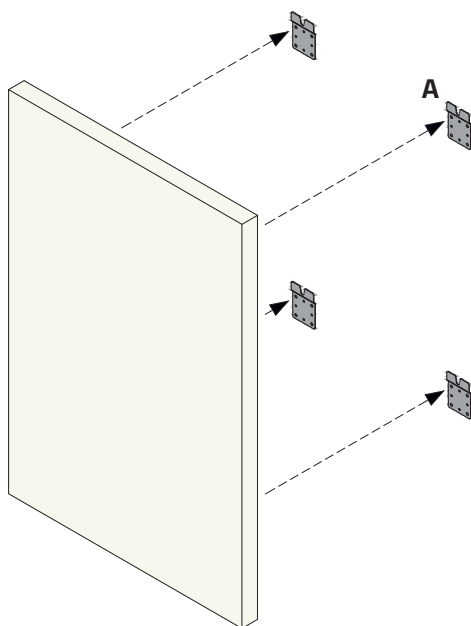

Detail A

Wall clip

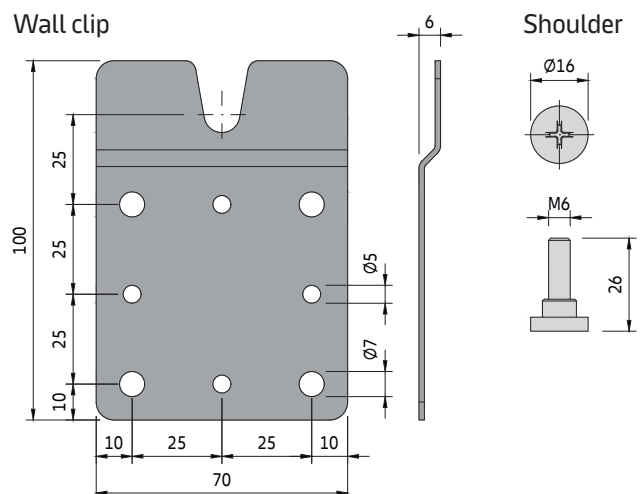

Fasten the wall clips to the wall according to the spacing of the threads on the back of the wall absorbers. The wall clip has holes in two different dimensions. Depending on the type of the wall, determines which wall fixing can be used.

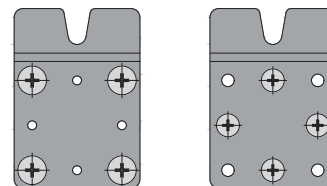

Vario Design layout options

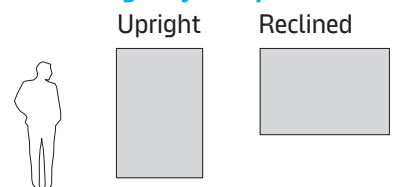

Wall absorber edge detail options

90° edge

50° edge

20x20 mm edge

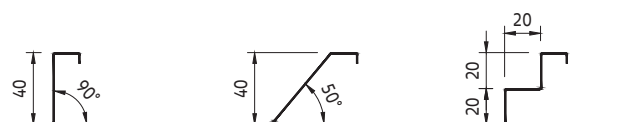

Orientation

Upright installation

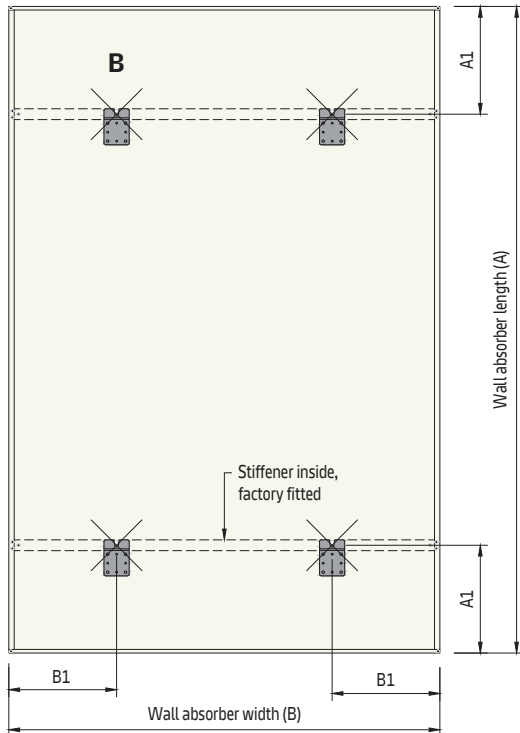

Reclined installation

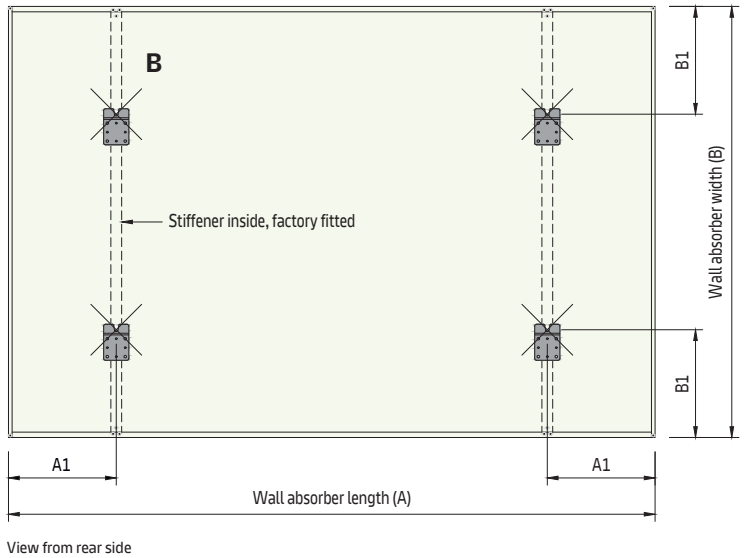

Important information

Please make sure that the visible side is protected during the assembly and cannot be scratched. In general, be careful when handling and transporting these large and heavy items. These wall absorbers are not designed for impact resistance.

Parameters

- A Wall absorber length = min. 600 / max. 1800 mm
- A1 (A = 600 - 899) = 100 - 150 mm
(A = 900 - 1800) = 150 - 300 mm
- B Wall absorber width = min. 600 / max. 1200 mm
- B1 (A = 600 - 899) = 100 - 150 mm
(A = 900 - 1200) = 150 - 300 mm

Detail B

Wall fixing

- 1 Insert the four shoulder bolts into the threads on the back of the wall absorber.

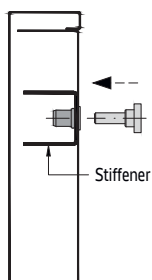

- 2 Hang the wall absorber on the wall clips with the four shoulder bolts. A distance of at least 20 mm is required from the upper edge of the wall absorber so that it can be hung.

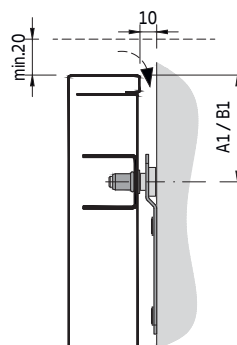



METAL Axal Vector
Gatwick Airport-South Terminal 1, London, United Kingdom
© James Sleight



Perimeter Trims & Transitions

METAL Perimeter Solutions

Range of perimeter trims for metal ceilings
For indoor application

General information

- Solutions for small, medium and large rooms, as well as corridors
- Perimeter trims made of aluminium and steel
- Perimeter trims for most common construction
- Shadowline trims for alternative construction (shadow gap)
- Available in standard RAL 9010, further colour options on request
- Pressure spring for F-perimeter trims
- Fixing spring and perimeter wedge available for some of the trims
- Curved trims and column rings

Aluminium perimeter trims

RA 1 perimeter trim

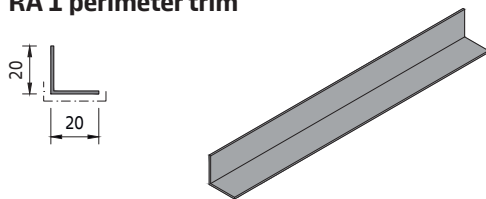

RA 2 perimeter trim

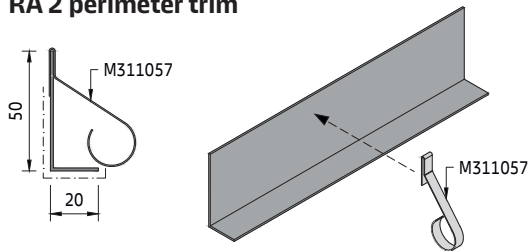

RA 3 shadowline perimeter trim

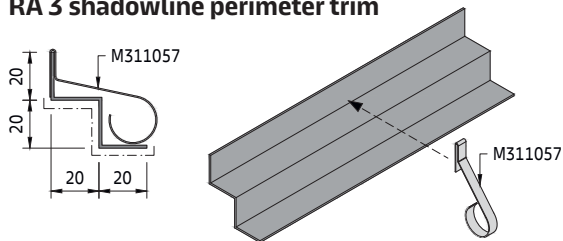

Aluminium F-perimeter trims

RA 4 F perimeter trim

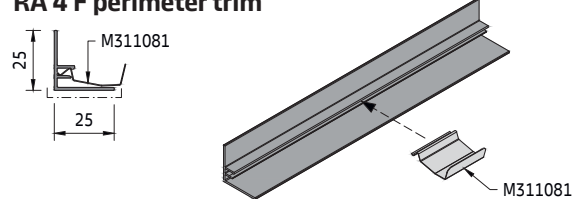

RA 5 F shadowline perimeter trim

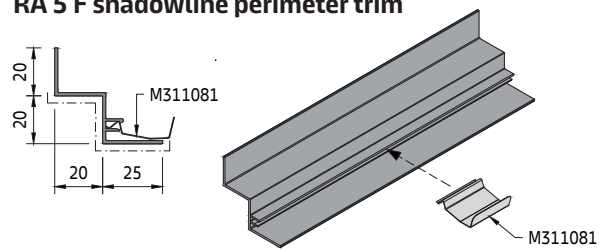

RA 6 F shadowline perimeter trim

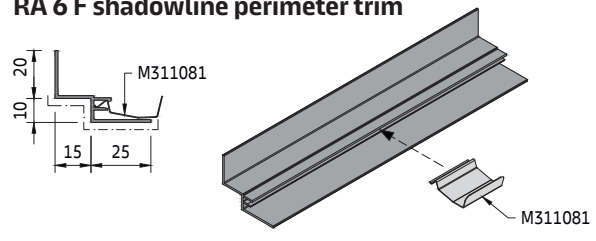

RA 9 F perimeter trim

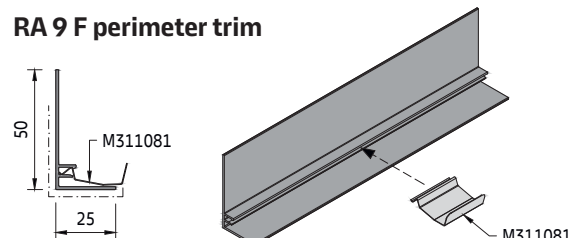

----- Coated surface

METAL Perimeter Solutions

T02.001

Galvanised steel perimeter trims

RA 1 S perimeter trim

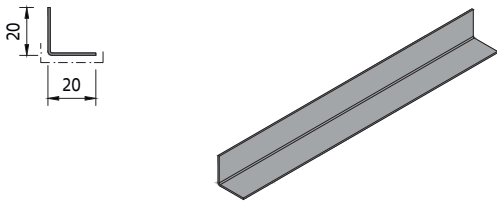

Perimeter L

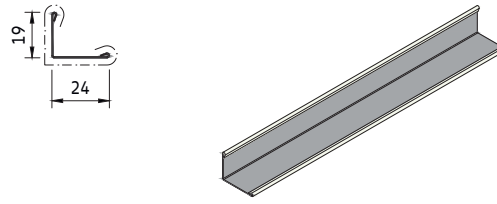

RA 3 S shadowline perimeter trim

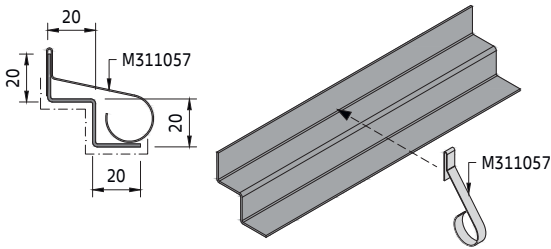

Shadowline perimeter

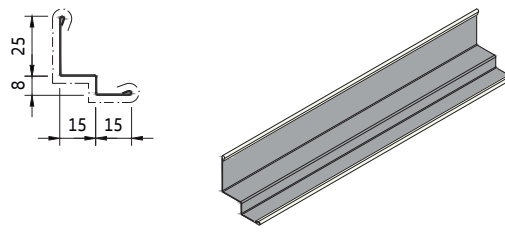

Generally, installation has to be carried out with approved fixings suitable for the type of wall being fixed to. Flat headed screws are recommended to prevent deformation of the trim. Wall fixings are not offered by Knauf Ceiling Solutions.

Cut tiles/panels can be hold-down with springs or wedges.

Perimeter C

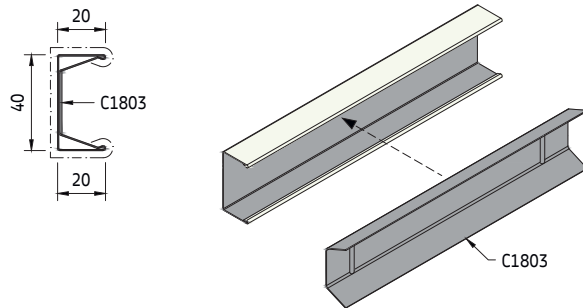

Perimeter trims		Length (L) [mm]	max. (X) [mm]	min. (Y) [mm]
M215110	RA 1	4000	600	12
M215111	RA 2	4000	600	12
M215112	RA 3	4000	600	14
M215013	RA 4 F	4000	600	13
M215014	RA 5 F	4000	600	13
M215015	RA 6 F	4000	600	13
M215233	RA 9 F	4000	600	13
M215213	RA 1 S	3000	600	12
M215214	RA 3 S	3000	600	14
Various	Perimeter L 19 x 24 mm	3000	400	16
Various	Shadowline perimeter trim 25 x 15 x 8 x 15 mm	3000 / 3050	400	10
Various	Perimeter C 20 x 40 x 20 mm	3000 / 3050	400	14

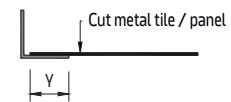
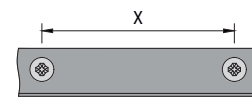

METAL Perimeter Solutions

T02.001

Perimeter trim corner details

For 90° corners, perimeter trims are recommended to be butt cut. Mitred cuts require increased precision and time.

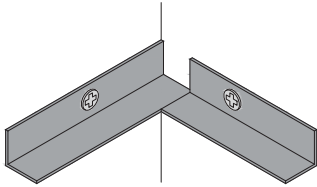
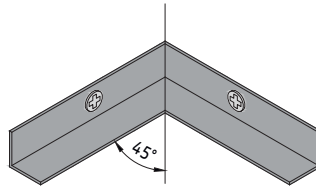
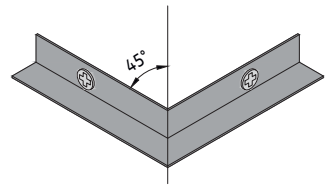
Butt-cut inside corner**Mitre-cut inside corner****Mitre-cut outside corner****Shadowline perimeter trim corner details**

Shadowline perimeter trims should be mitred as standard.

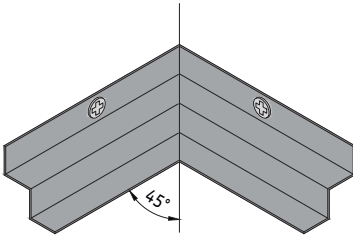
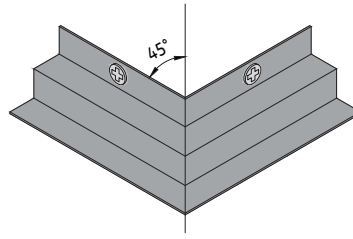
Mitre-cut inside corner**Mitre-cut outside corner****Accessories**

- C1803 Perimeter wedge
- M311057 Fixing spring
- M311081 Pressure spring (for F-perimeter trims)

METAL Perimeter Solutions

T02.001

Curved perimeter trims

Some standard perimeter trims can be supplied curved on request. With this, details for curved walls, skylights, column rings, etc. can be solved.

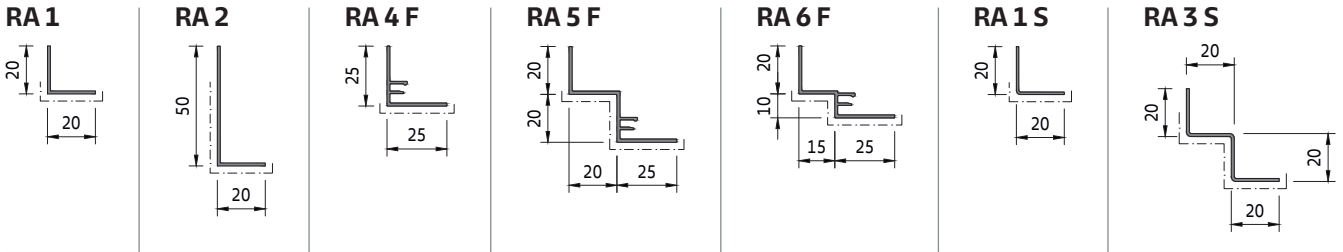

The ends of the perimeter trims are supplied straight and must be cut on site. In this way, they can be fitted and structural tolerances can be accommodated.

Curved outward

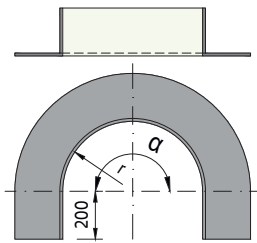

Curved inside

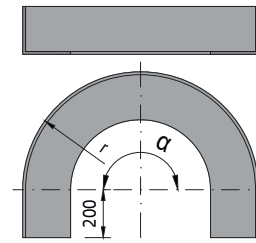

Curved perimeter trims	Curved outward Radius (r) min. [mm]	Curved inside Radius (r) min. [mm]	Angle (α) max. [mm]
RA 1 curved	90	750	180
RA 2 curved	300	750	180
RA 4 F curved	90	1000	180
RA 5 F curved	125	1500	180
RA 6 F curved	115	2000	180
RA 1 S curved	90	750	180
RA 3 S curved	120	800	180

Column rings

Column rings are delivered in two parts, which simplifies assembly.

Semi-circular column ring

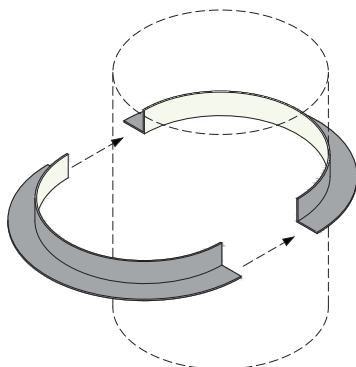

Semi-circular shadowline column ring

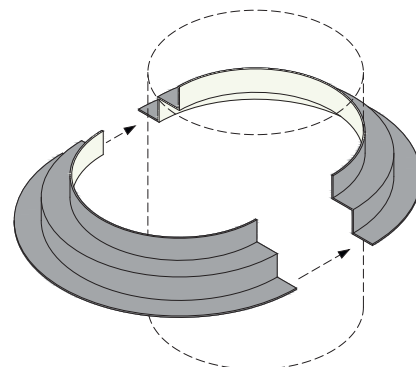

----- Coated Surface

METAL Steel Bulkhead Solutions

Range of bulkheads for metal ceilings
For indoor application

General information

- Solutions for small, medium and large rooms, as well as corridors
- Bulkheads made of steel
- A range of standard bulkheads and Vario Design options
- Available in standard RAL 9010, further colour options on request
- For vertical closure and change in level
- Inside / outside corner options on request

Application area

Vertical closure

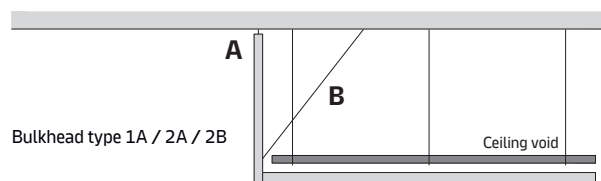

Change in level

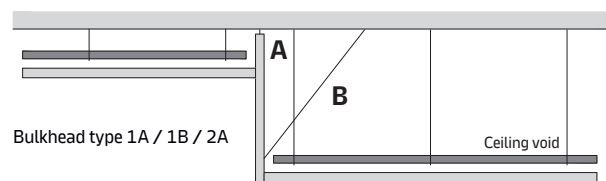

Bulkhead orientation

Reclined

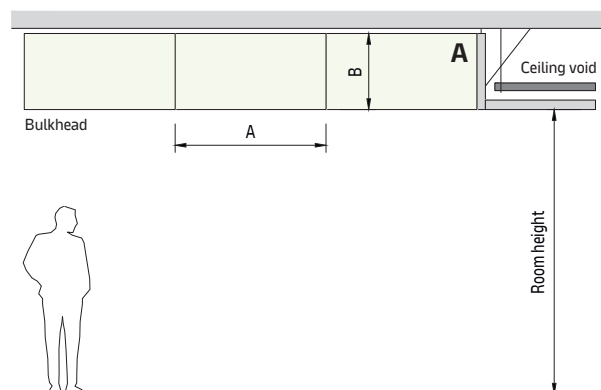

Upright

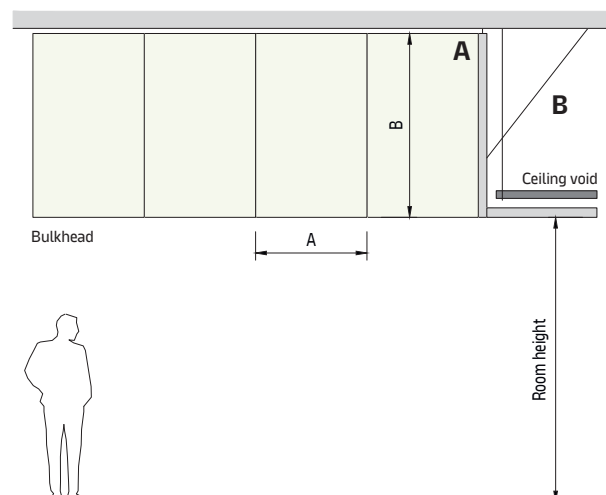

METAL Steel Bulkhead Solutions

T02.002

Detail A

Threaded rod

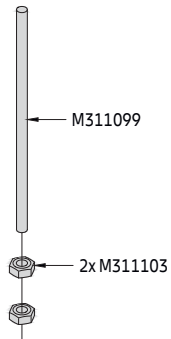

Bulkhead type 1A / 1B / 2A

Attachment bracket

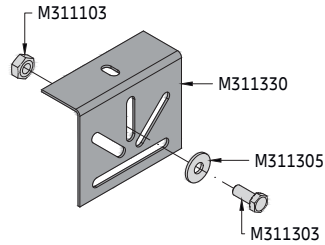

Bulkhead type 1B

Depending on the bulkhead type and detail, two suspension options are available.

- a0 Distance between suspension points = max. 600 mm
- a1 Distance from bulkhead end to suspension point = max.300 mm

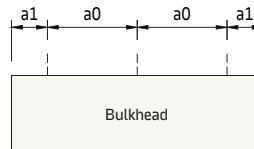

Detail B

Angle bracing

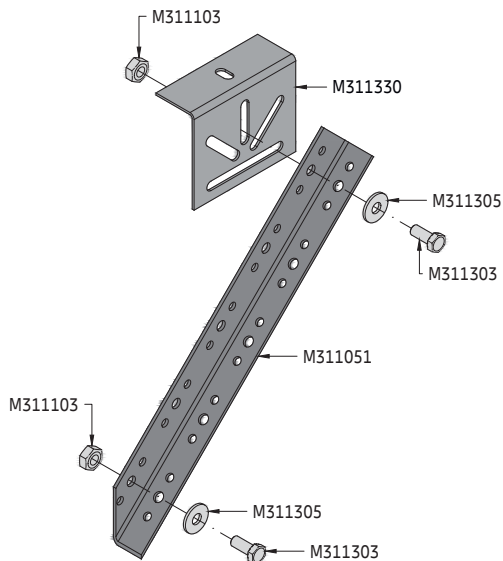

The bulkheads must be secured with an angle bracing in the lower half. A primary angle is suitable for this, which is attached to the bulkhead with M6 bolts.

The angle bracing is attached at an angle of max. 45°.

At the top, an attachment bracket gets fixed to the soffit. The primary angle is secured through the long holes in the bracket using an M6 nut and bolt.

Accessories		Length (L) [mm]
M215111	RA 2	4000
M215013	RA 4 F	4000
M215014	RA 5 F	4000
M311051	Primary angle 3000 x 27 x 22 mm	3000
M311081	Pressure spring (for F-perimeter trims)	-
M311099	Threaded rod M6 x 1000 mm	1000
M311103	Hexagonal nut M6	-
M311105	Washer	-
M311303	Hexagonal bolt M6 x 16 mm	-
M311330	Attachment bracket	-
M311191	Self-drilling screw 3.5 x 9.5 mm	-

Bulkhead type 1A

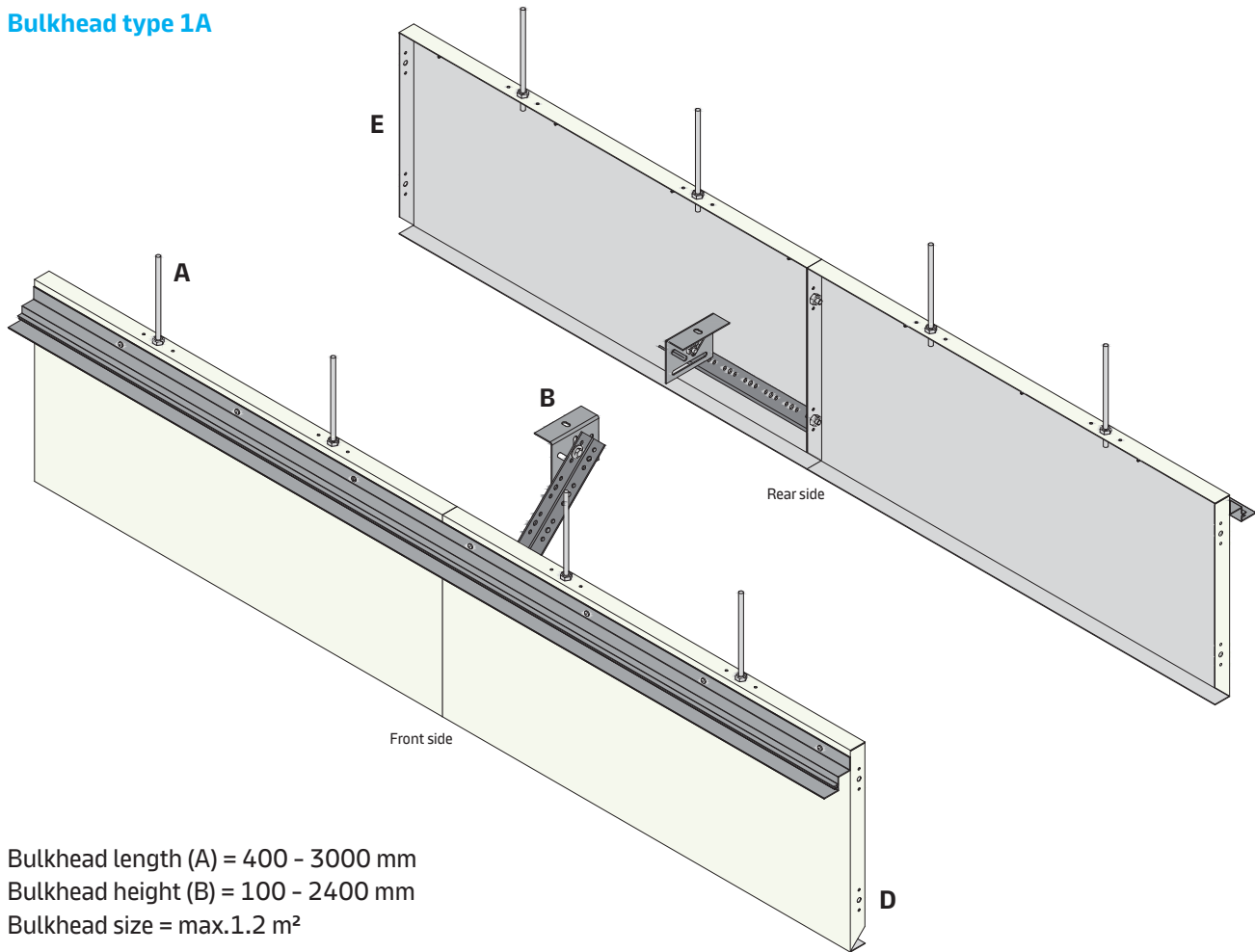

Bulkhead length (A) = 400 - 3000 mm
 Bulkhead height (B) = 100 - 2400 mm
 Bulkhead size = max.1.2 m²

Option C1
Vertical closure

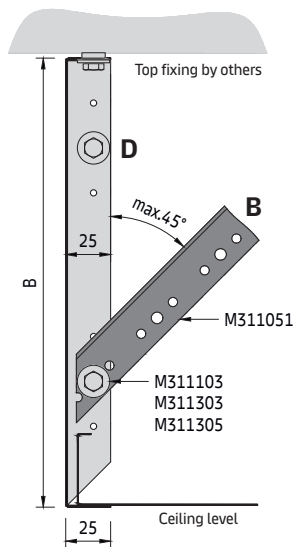

Option C2
Change in level with RA 4 F

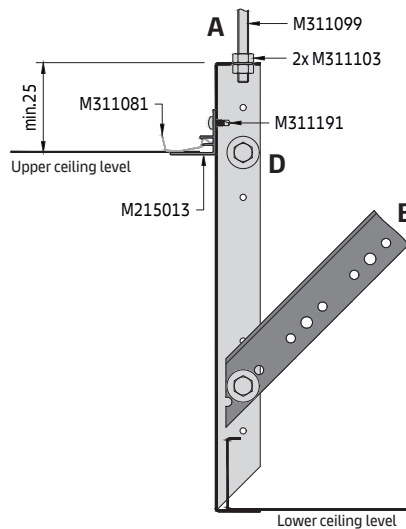

Option C3
Change in level with RA 5 F

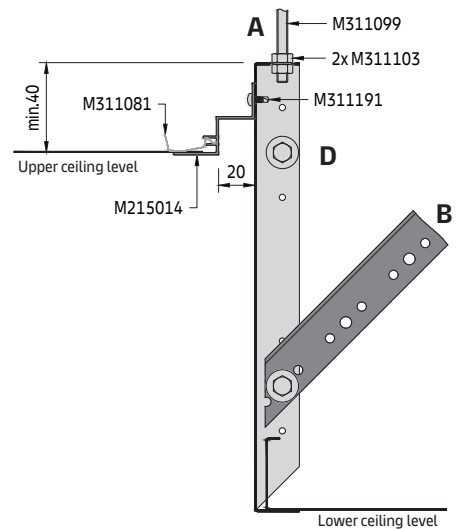

Detail D

Bulkhead connection

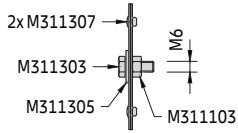

The bulkheads can either be connected by two pop-rivets or a M6 nut and bolt.

Option E1

Cut bulkhead wall detail with RA 4 F

Perimeters fixed to the bulkhead in a distance of max. 600 mm.
Perimeter solutions see separate datasheet.

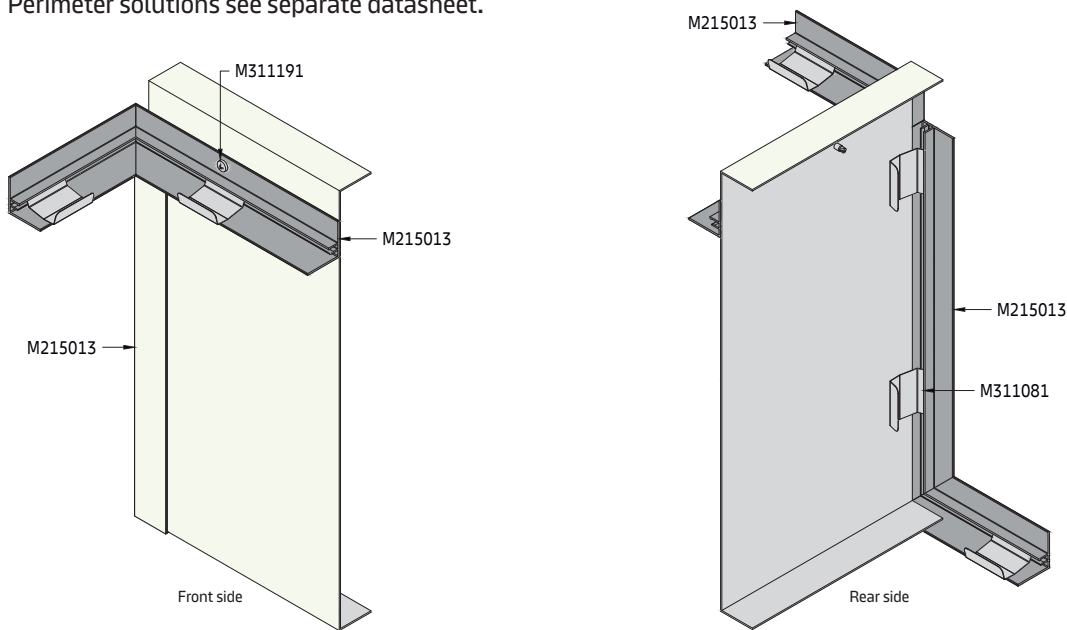

Option E2

Cut bulkhead wall detail with RA 5 F

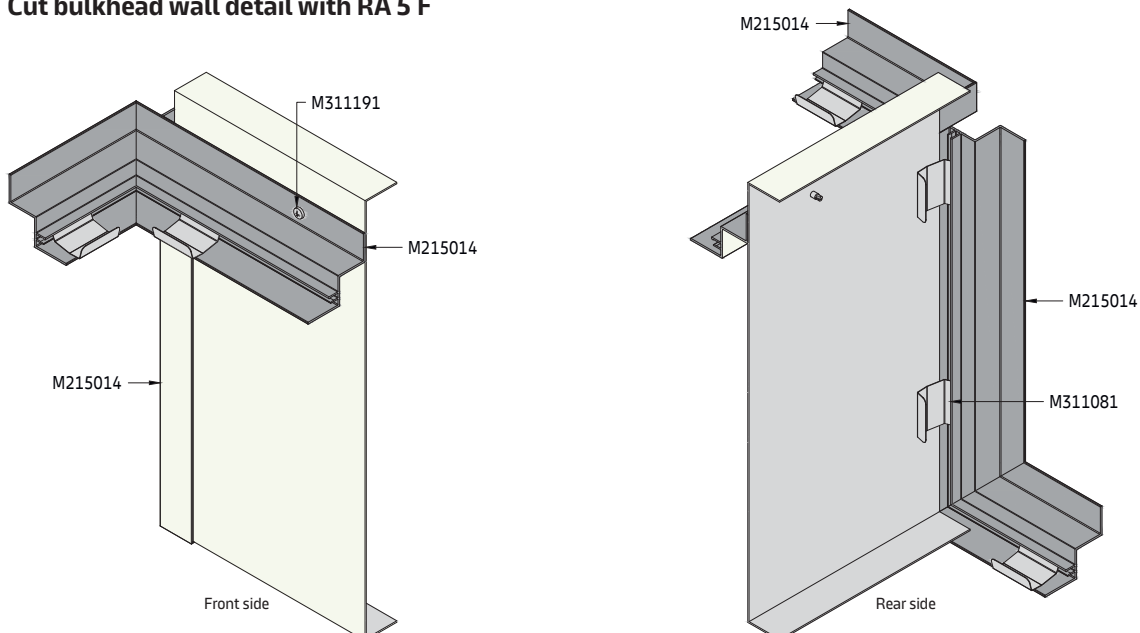

Bulkhead type 1B

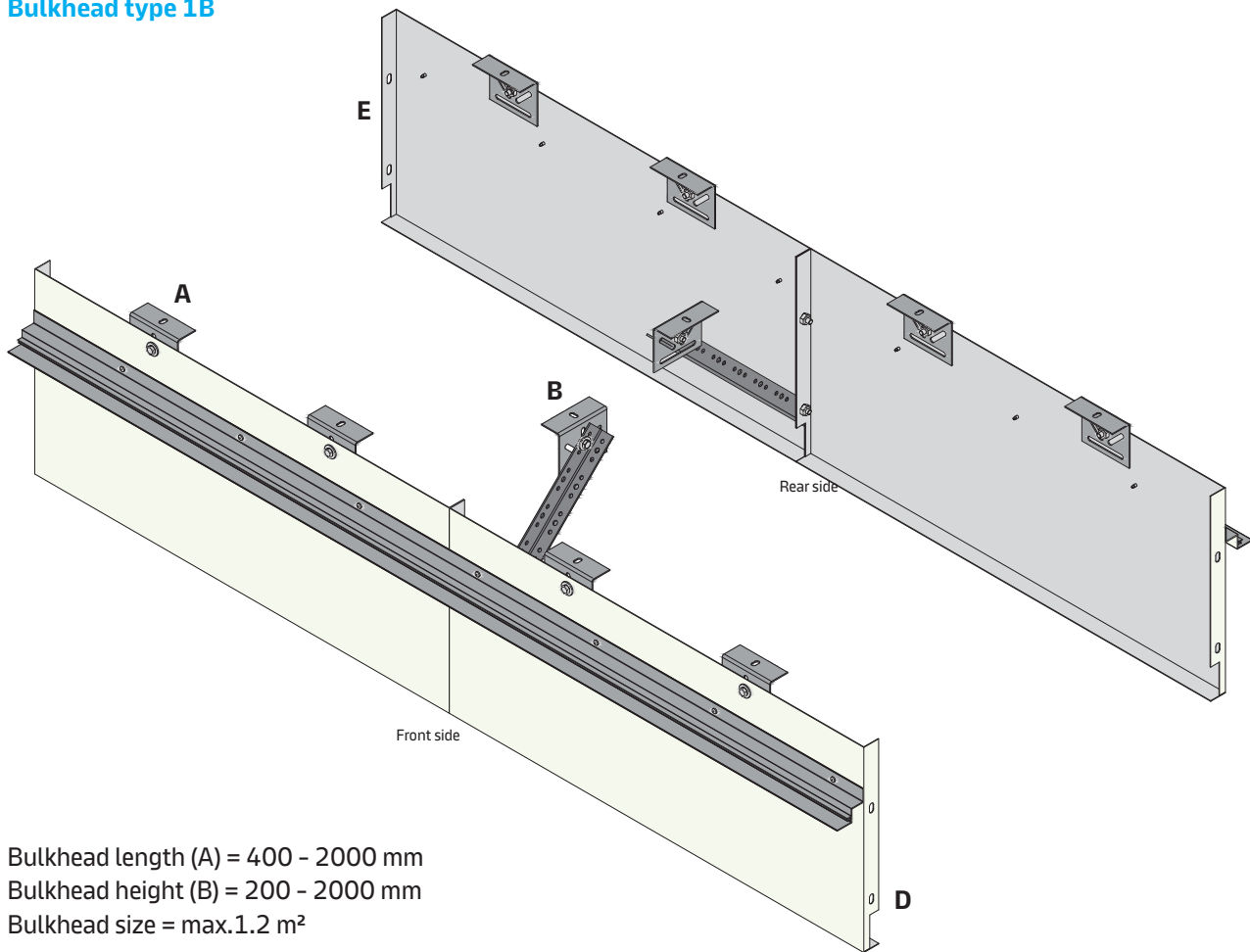

Bulkhead length (A) = 400 - 2000 mm
 Bulkhead height (B) = 200 - 2000 mm
 Bulkhead size = max.1.2 m²

Option C1

Change in level with RA 4 F

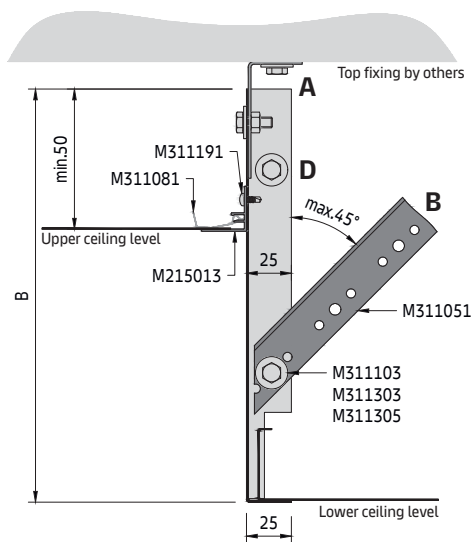

Option C2

Change in level with RA 5 F

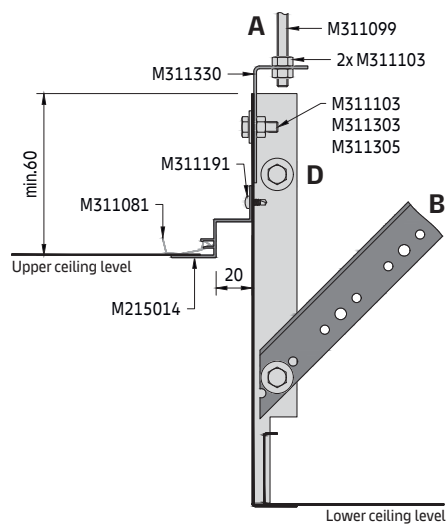

Detail D

Bulkhead connection

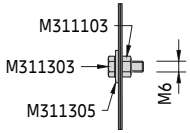

Option E1

Cut bulkhead wall detail with RA 4 F

Perimeters fixed to the bulkhead in a distance of max. 600 mm.

Perimeter solutions see separate datasheet.

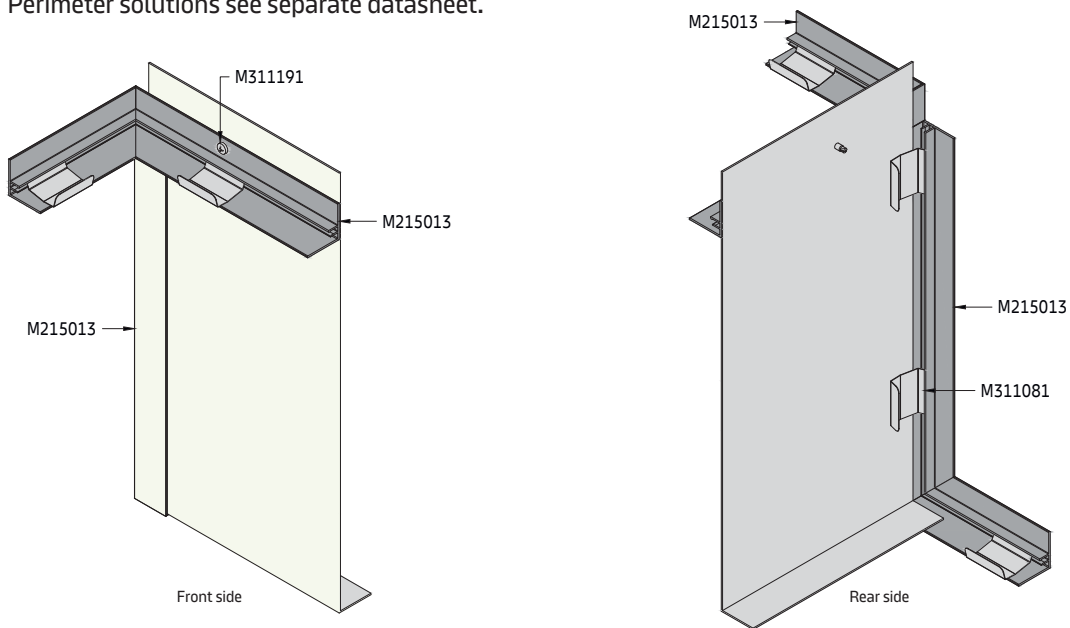

Option E2

Cut bulkhead wall detail with RA 5 F

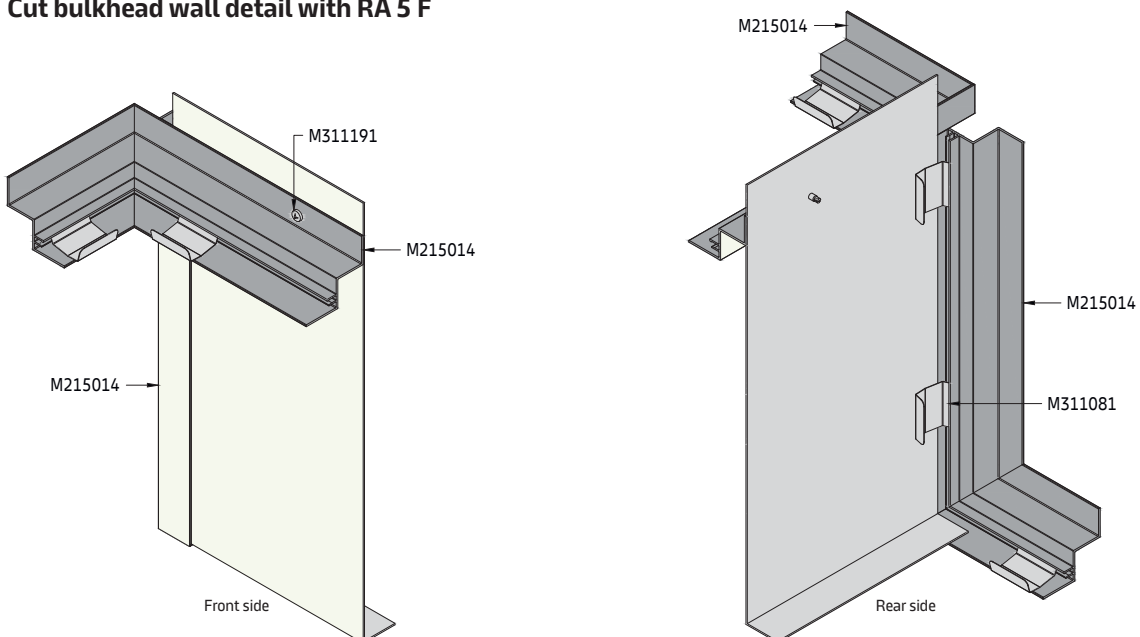

Bulkhead type 2A

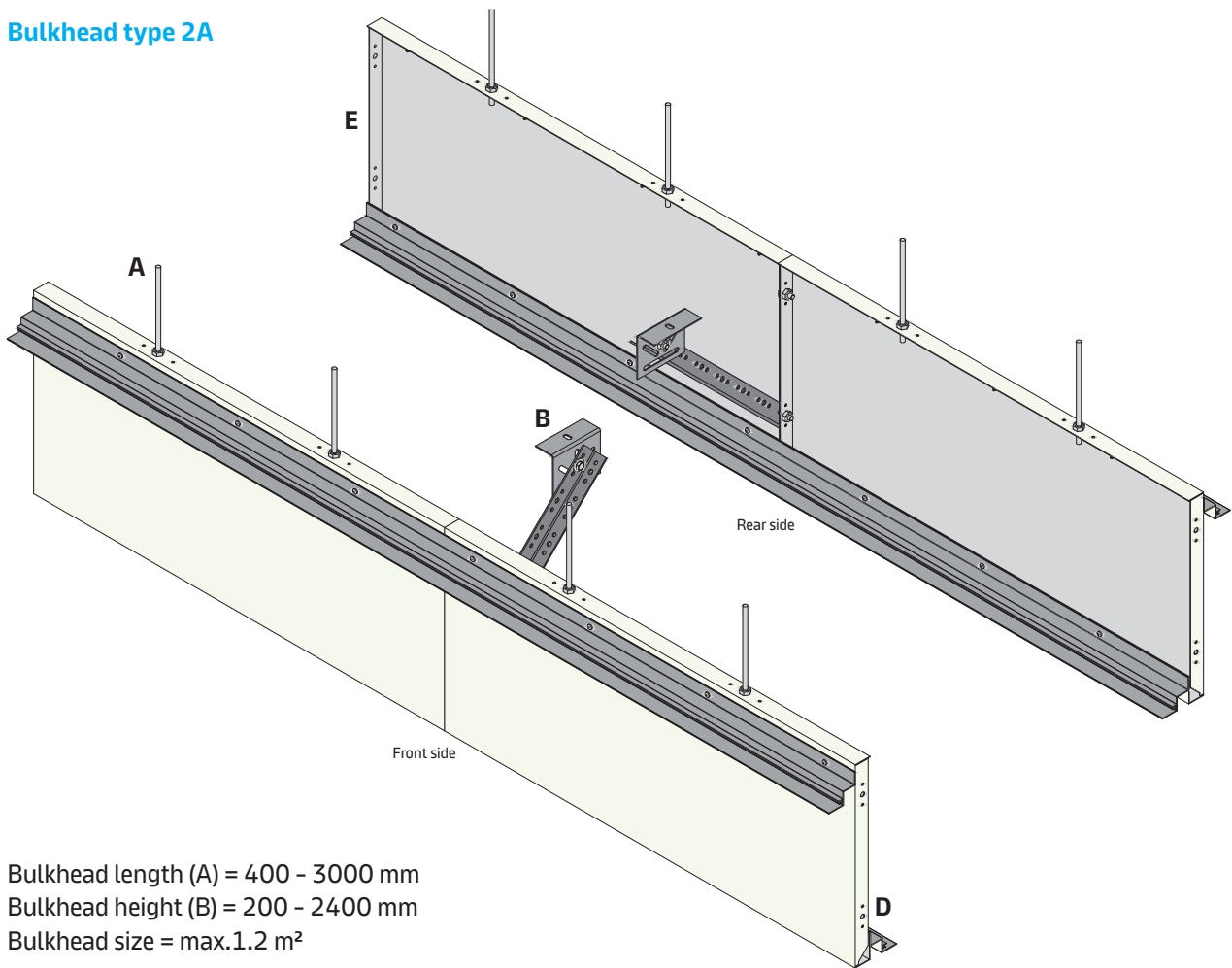

Bulkhead length (A) = 400 - 3000 mm
 Bulkhead height (B) = 200 - 2400 mm
 Bulkhead size = max.1.2 m²

Option C1
 Vertical closure

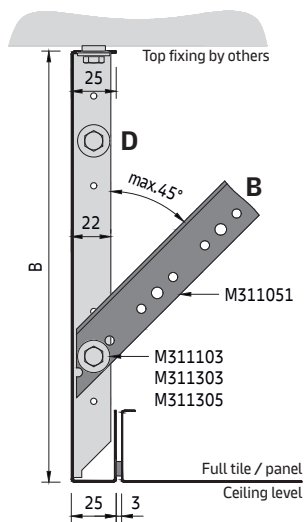

Option C2
 Change in level with RA 4 F

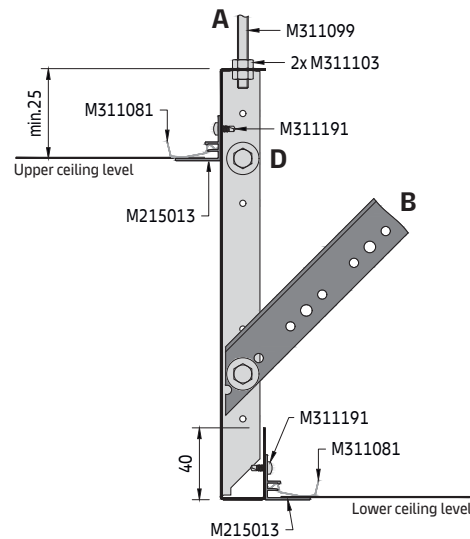

Option C3
 Change in level with RA 5 F

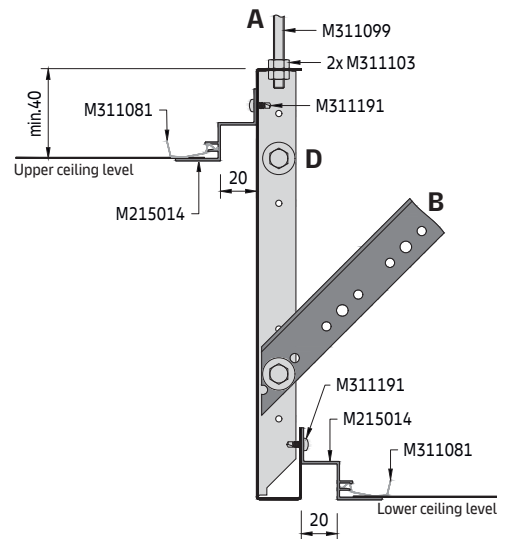

Detail D

Bulkhead connection

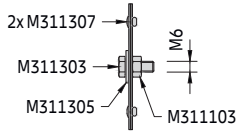

The bulkheads can either be connected by two pop-rivets or a M6 nut and bolt.

Option E1

Cut bulkhead wall detail with RA 4 F

Perimeters fixed to the bulkhead in a distance of max. 600 mm.
Perimeter solutions see separate datasheet.

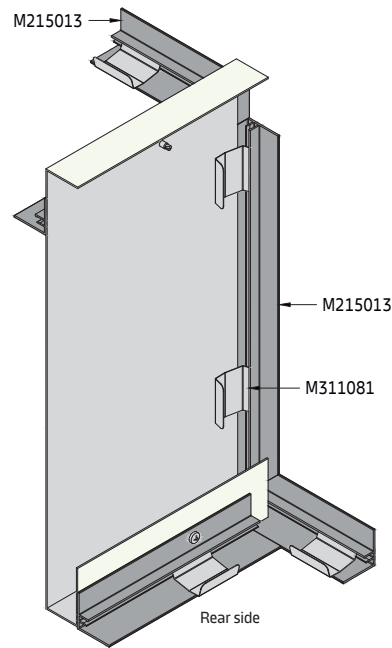
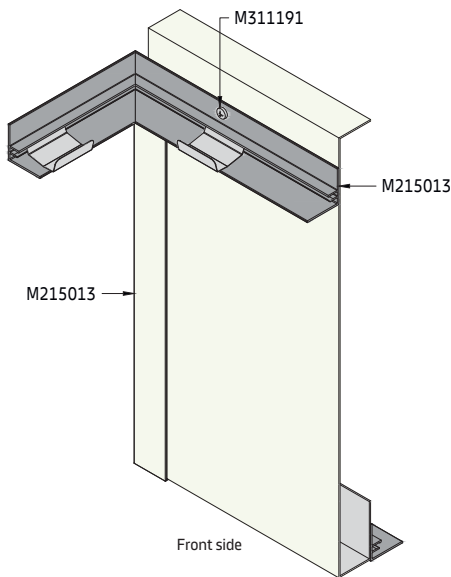

Option E2

Cut bulkhead wall detail with RA 5 F

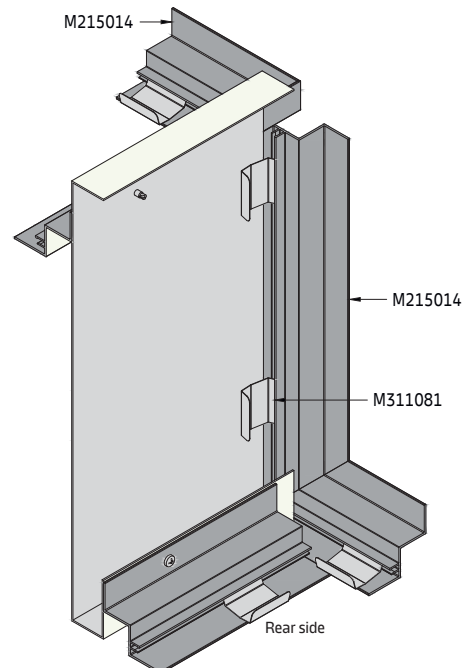
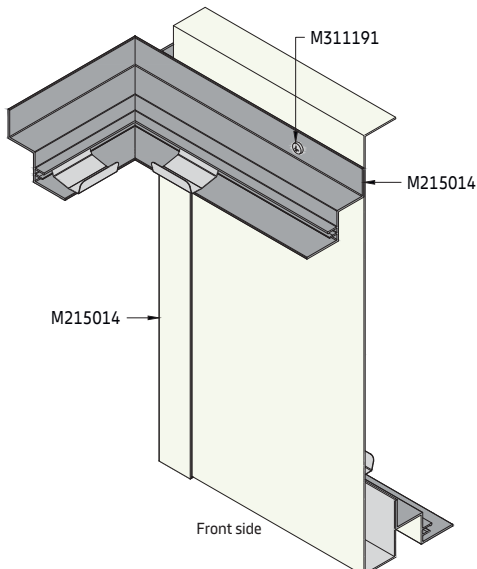

Bulkhead type 2B

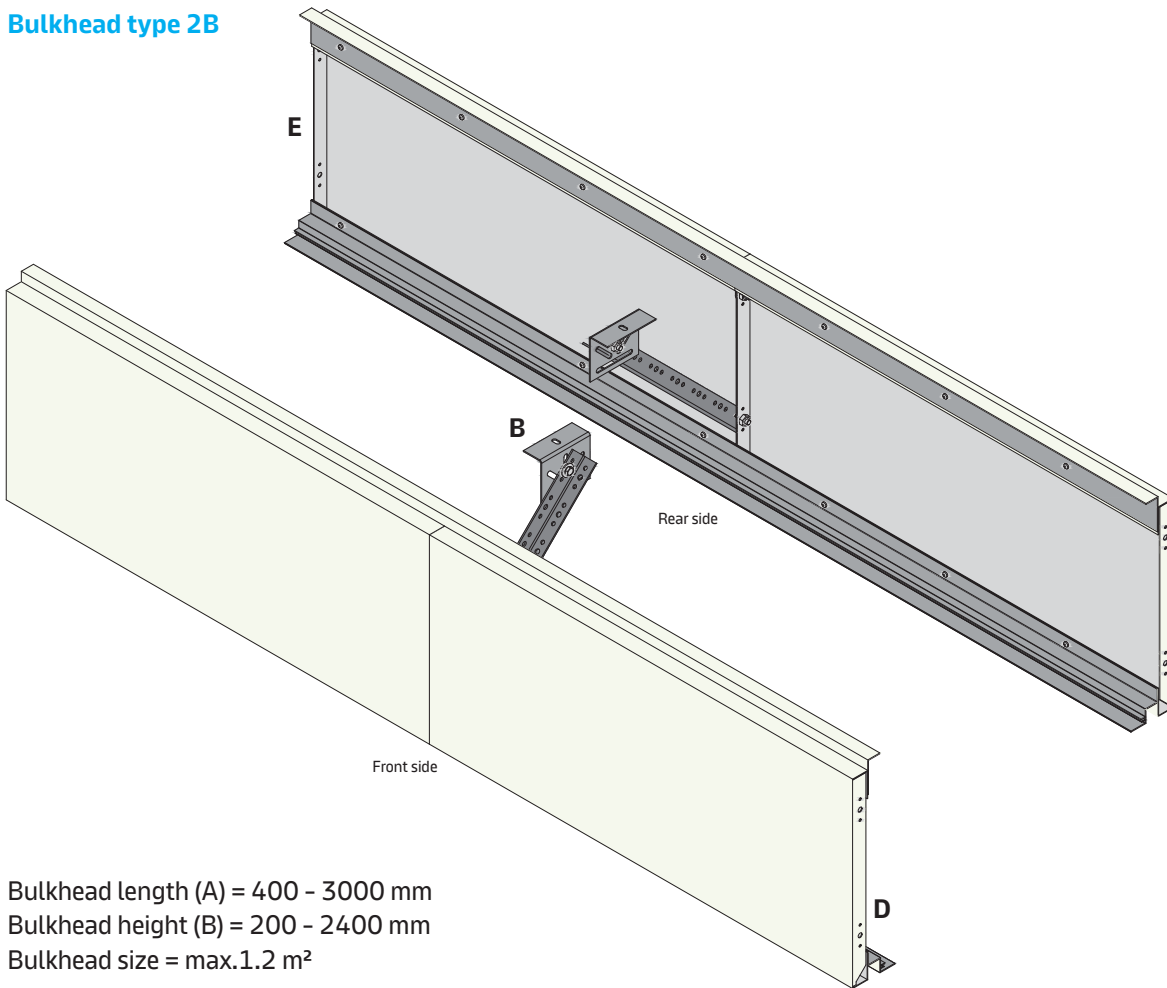

Bulkhead length (A) = 400 - 3000 mm
 Bulkhead height (B) = 200 - 2400 mm
 Bulkhead size = max.1.2 m²

Option C1
 Vertical closure

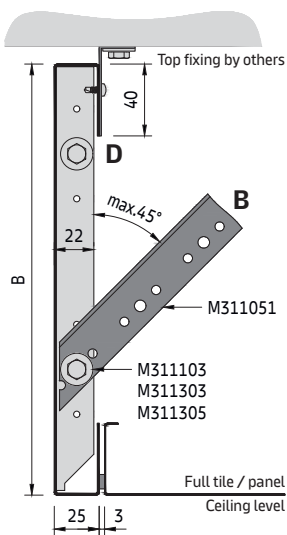

Option C2
 Change in level with RA 4 F

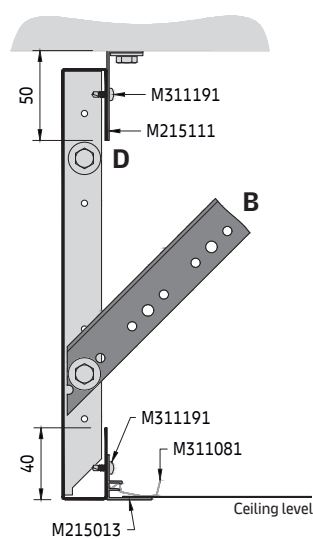

Option C3
 Change in level with RA 5 F

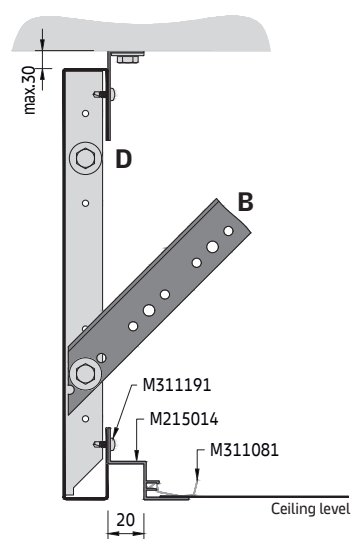

Detail D

Bulkhead connection

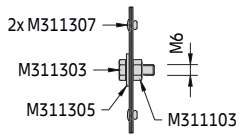

The bulkheads can either be connected by two pop-rivets or a M6 nut and bolt.

Option E1

Cut bulkhead wall detail with RA 4 F

Perimeters fixed to the bulkhead in a distance of max. 600 mm. Perimeter solutions see separate datasheet.

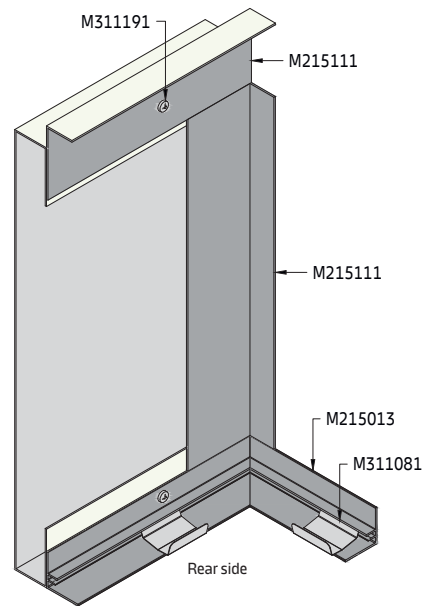
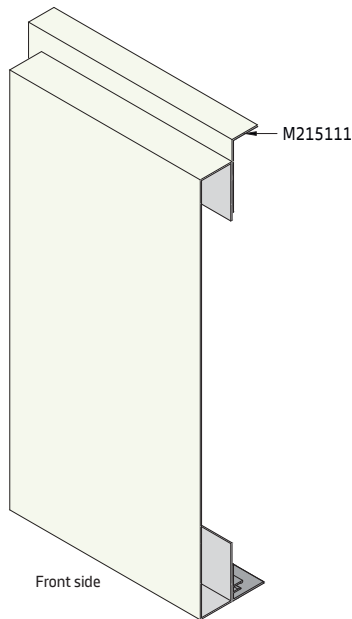

Option E2

Cut bulkhead wall detail with RA 5 F

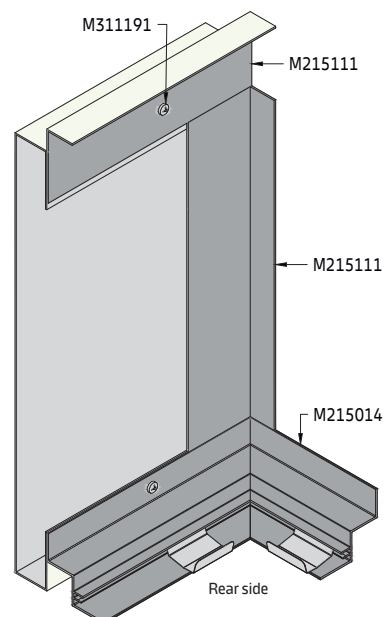
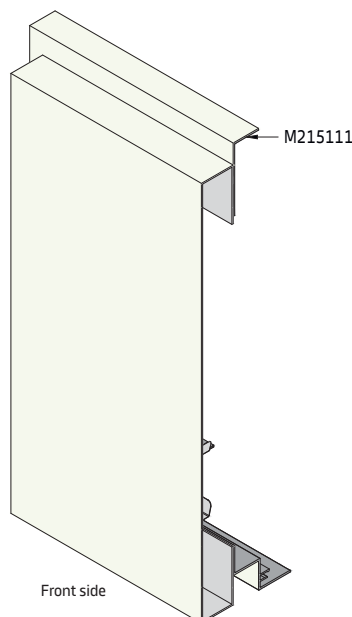

METAL Aluminium Bulkhead Solutions

Range of bulkheads for metal ceilings
For indoor applications

General information

- Solutions for medium and large rooms
- A range of standard bulkheads made of aluminium
- Available in standard RAL 9010, further colour options on request
- Bulkhead, change in level and frame solution
- Suitable for ceiling solutions with a system height of 98 mm
- Inside / outside corner options
- Curved bulkheads on request

Isometric view

Select the suspension option G1 - G4.

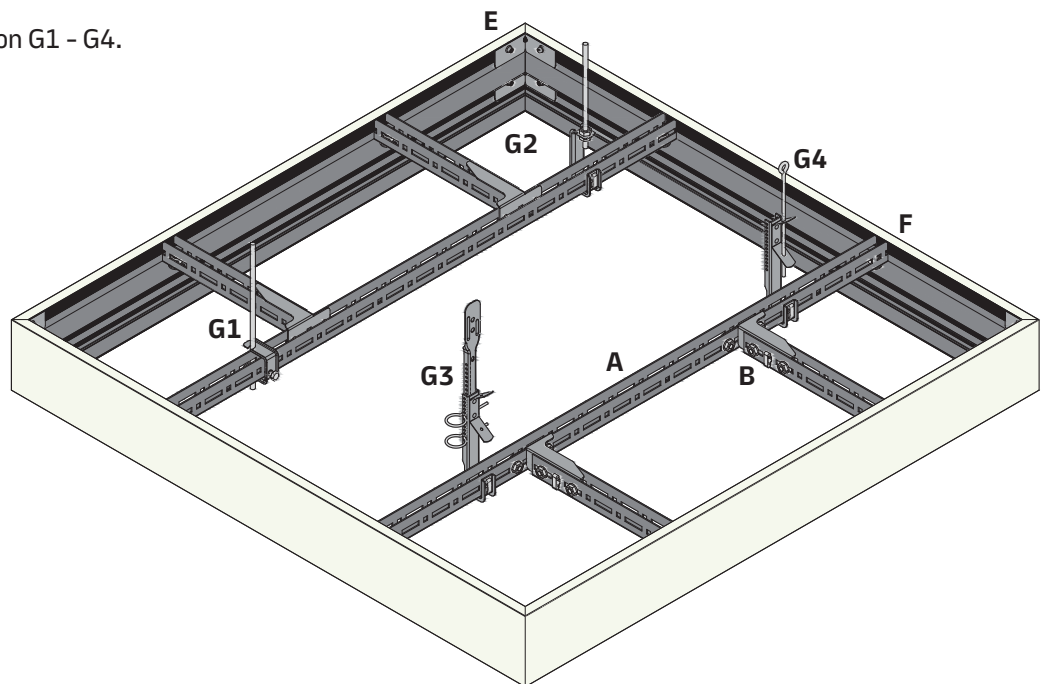

Vario Design & bespoke layout options

Vario Design

Square frame with square tiles

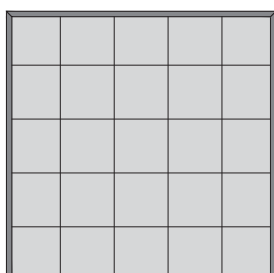

Square frame with rectangular panels

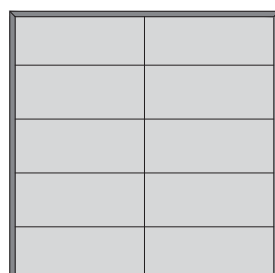

Bespoke (on request)

Circular frame with square tiles

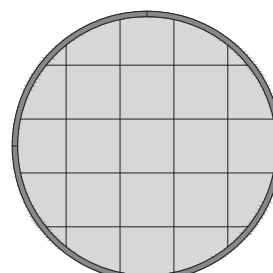

Circular frame with rectangular panels

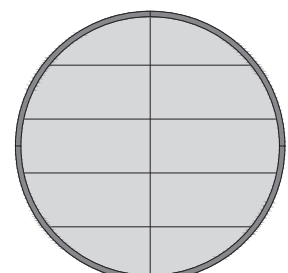

METAL Aluminium Bulkhead Solutions

T02.003

Grid components

Standard components

- M215562 Perimeter profile RAL 9010
- M215560 Bulkhead 4" RAL 9010
- M215561 Bulkhead 6" RAL 9010
- M315450 Splice connector for bulkhead
- M300100 U-Profile
- M300119 Splice connector for U-Profile
- M315710 Cross-connector for U-Profile
- M300120 Plug-in clip for U-Profile
- M311195 Thread cutting screw M6 x 10 mm

- M311103 Hexagonal nut M6
- M311105 Washer
- M311303 Hexagonal bolt M6 x 16 mm
- M311081 Pressure spring

Optional components

- M215013 RA 4 F
- M215014 RA 5 F
- M311191 Self-drilling screw 3.5 x 9.5 mm

Suspension option G1

- M300121 Clamping bracket for U-Profile
- M311101 Threaded rod M6 x 1000 mm
- M311315 Hexagonal extension nut M6 x 30 mm (optional)
- M311061 Suspension element (optional)

Suspension option G3

- M300166 Combi-Nonius hanger for U-Profile
- - Nonius top part (various lengths)
- M300036 Nonius locking pin
- M300120 Plug-in clip for U-Profile

Suspension option G2

- M300366 Hanger for U-Profile
- M311103 Hexagonal bolt M6
- M300120 Plug-in clip for U-Profile
- M311315 Hexagonal extension nut M6 x 30 mm (optional)
- M311061 Suspension element (optional)

Suspension option G4

- M300166 Combi-Nonius hanger for U-Profile
- - Eye wire (various lengths)
- M300120 Plug-in clip for U-Profile

Perimeter profile

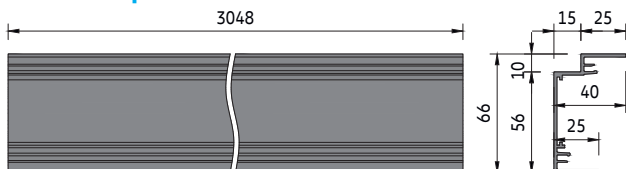

Bulkhead 4"

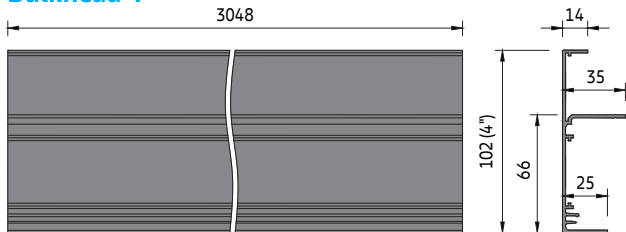

Bulkhead 6"

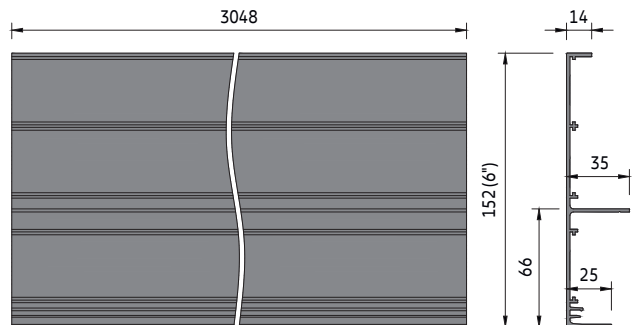

U-Profile grid

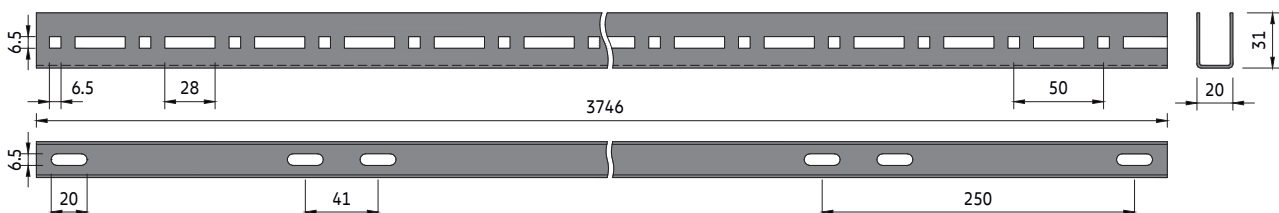

Application areas

1 side with bulkhead

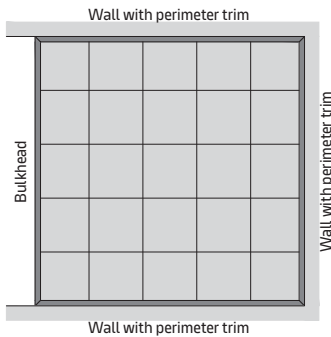

2 sides with bulkhead

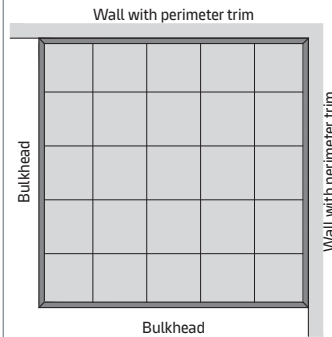

3 sides with bulkhead

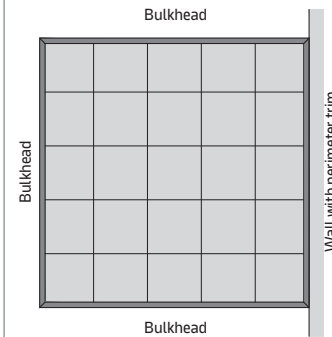

4 sides with bulkhead (frame)

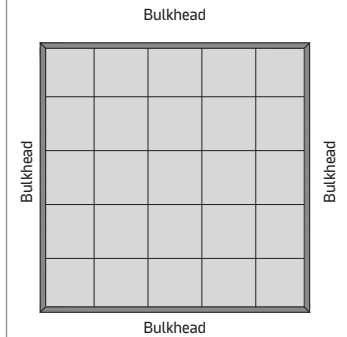

Typical grid layout

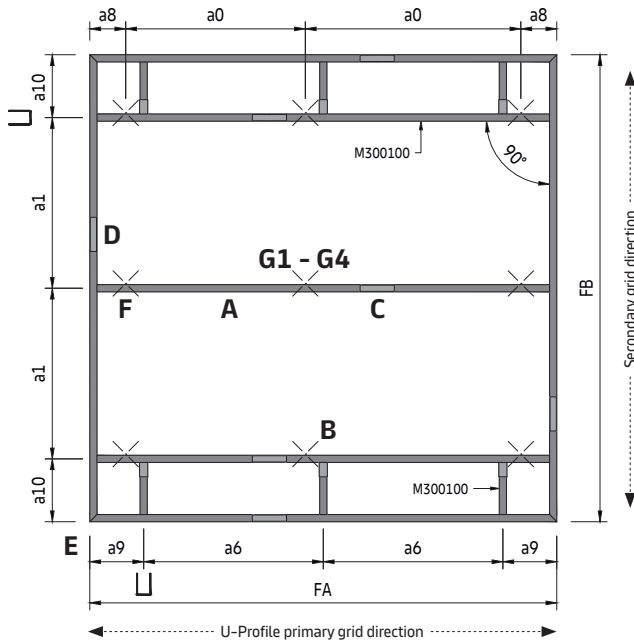

Parameters

- a0 Distance between U-Profile suspension points = max. 1900 mm
- a1 Max. distance between U-Profiles see selected system
- a6 Distance between U-Profiles = max. 1500 mm (in steps of 50 mm)
- a7 Distance from suspension point to cross connector = max. 100 mm
- a8 Distance to bulkhead = min. 50 / max. 250 mm
- a9 Distance to bulkhead = min. 100 / max. 300 mm
- a10 Distance to bulkhead = min. 50 / max. 250 mm
- a11 Distance to bulkhead = min. 50 / max. 125 mm
- FA Frame length = min. 1200 / no max. limit
- FB Frame width = min. 1200 / no max. limit
- L Bulkhead length = 3048 mm

Detail A

U-Profile modulation

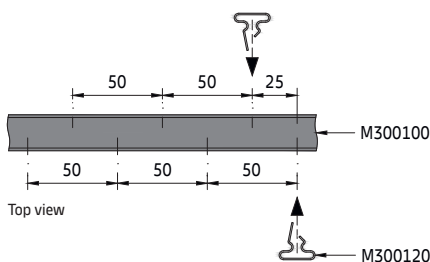

The U-Profile primary grid is a modular system based on a spacing of 50 mm. The holes on the lateral sides are offset from each other by 25 mm. This means that increments of 25 mm can be achieved.

METAL Aluminium Bulkhead Solutions
T02.003

Detail B

U-Profile cross-connector installation

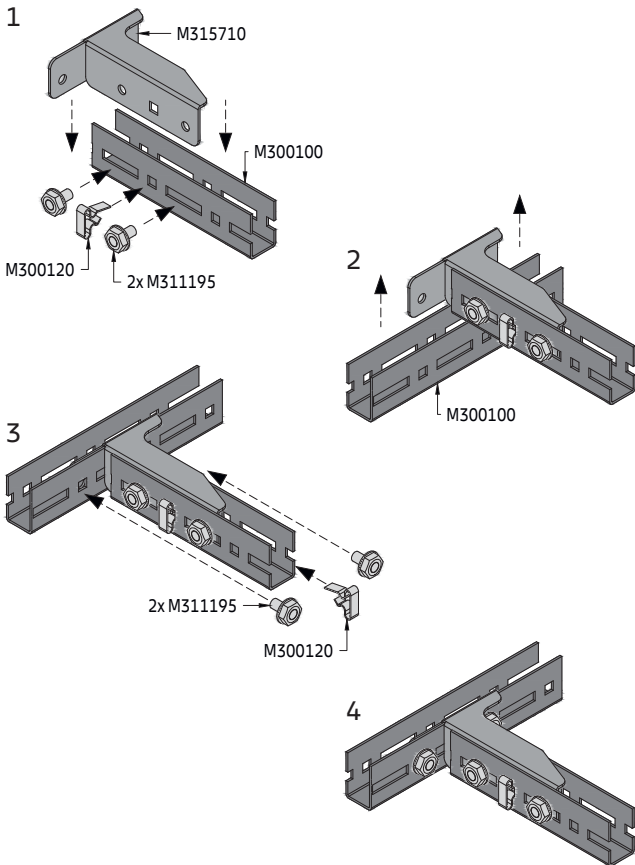

The cross-connector for U-Profile is fixed at both ends of the U-Profile primary grid. In order for this to work, a module dimension in 25 mm increments must be maintained. The plug-in clip can be used for positioning. The fixation itself is done with thread cutting screws. Standard M6 bolts cannot be used.

Align the lateral U-profile in the longitudinal direction and insert it so that the cross-connector is hooked.

Again use a plug-in clip and two thread cutting screws to fix the lateral U-Profile to the cross-connector.

The two profiles are now connected. Only a 90° connection is possible.

Detail C

U-Profile splice connection

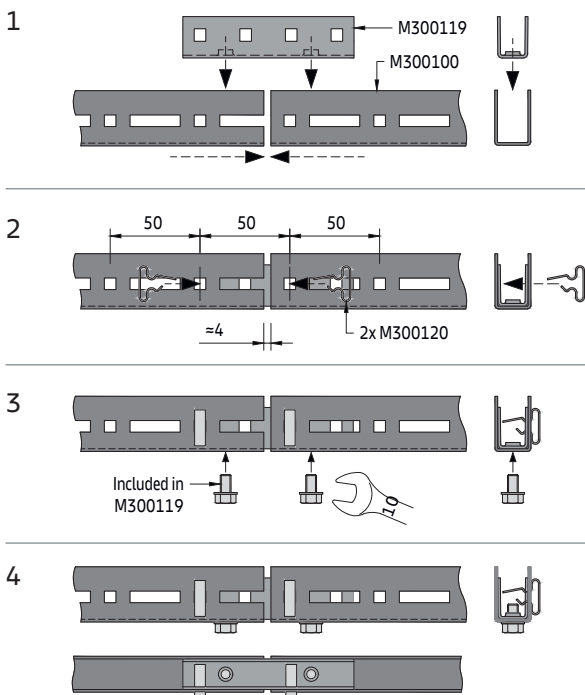

The splice connector for U-Profile comes with two bolts, which must first be removed. The splice connector is then placed between the two ends of the U-Profiles.

Fix the splice connector with two plug-in clips (large end upwards) at each end. This ensures the modular distance of 50 mm.

For a stable connection, the two supplied bolts are attached from below.

Since the U-Profile is a modular system, the ends must not touch. There is a distance of approx. 4 mm, depending on the length tolerance of the profile. Joints should be offset.

Detail D

Bulkhead splice connection

If necessary, cut the bulkhead to the required length. Make sure the face side is not damaged or scratched.

Bring the ends of the bulkheads and the the splice connector together. As soon as the gap is closed, the two bolts are tightened. Make sure that the bolts are not tightened too much, otherwise the visible side of the bulkhead could deform.

Perimeter profile - option 1

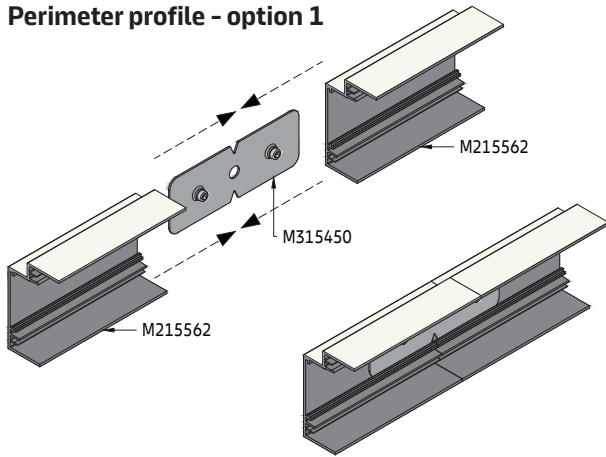

Perimeter profile - option 2

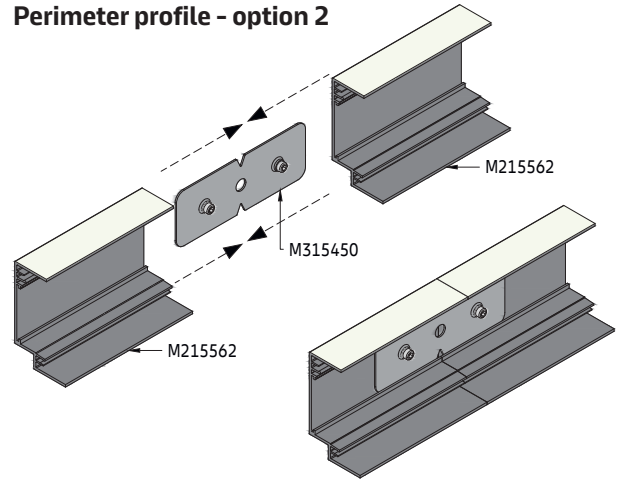

Bulkhead 4"

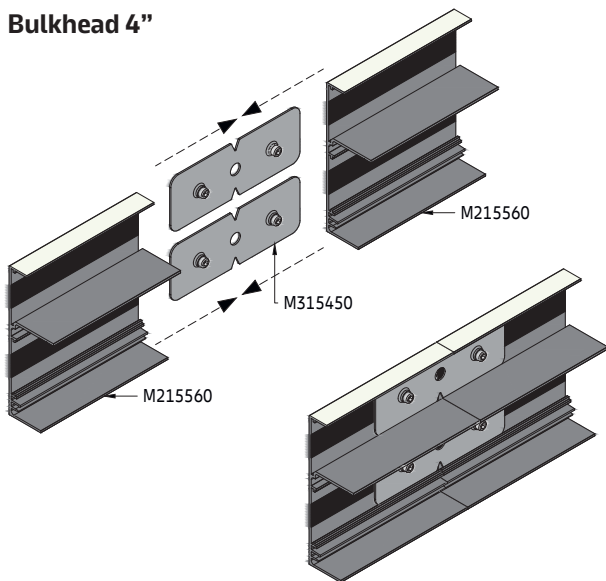

Bulkhead 6"

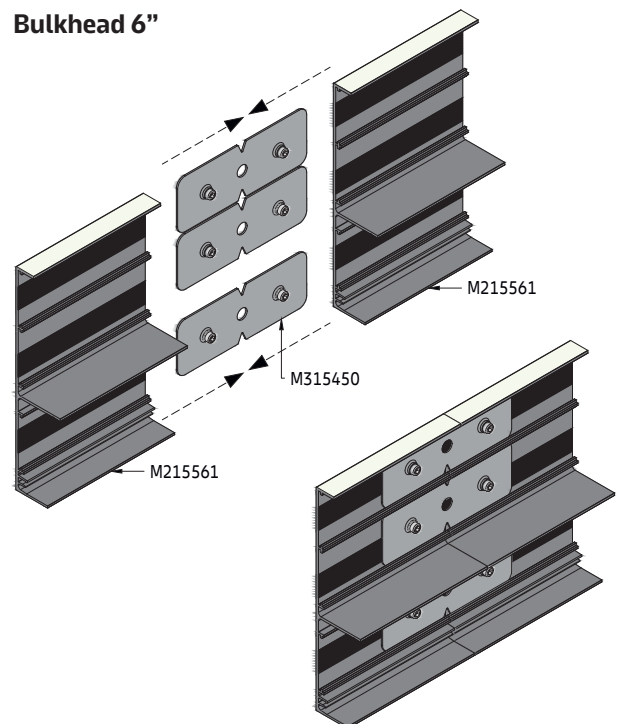

Detail E

Bulkhead corner connection

The bulkhead is carefully mitred. Make sure the face side is not damaged or scratched.

The splice connector for the straight connection is bent 90° by hand. In the case of an outside corner, it is bent in the opposite direction.

Bring the ends of the bulkheads and the splice connector together. As soon as the corner is closed, the two bolts are tightened. Make sure that the bolts are not tightened too much, otherwise the visible side of the bulkhead could deform.

Perimeter profile - option 1

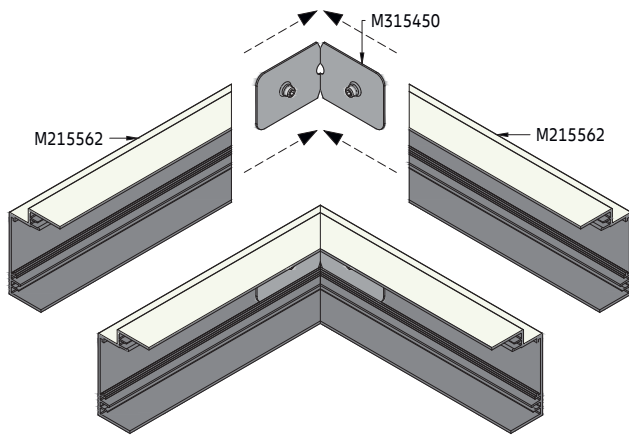

Perimeter profile - option 2

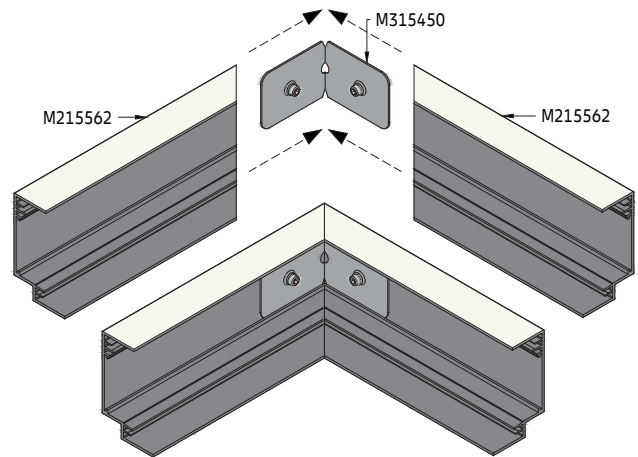

Bulkhead 4"

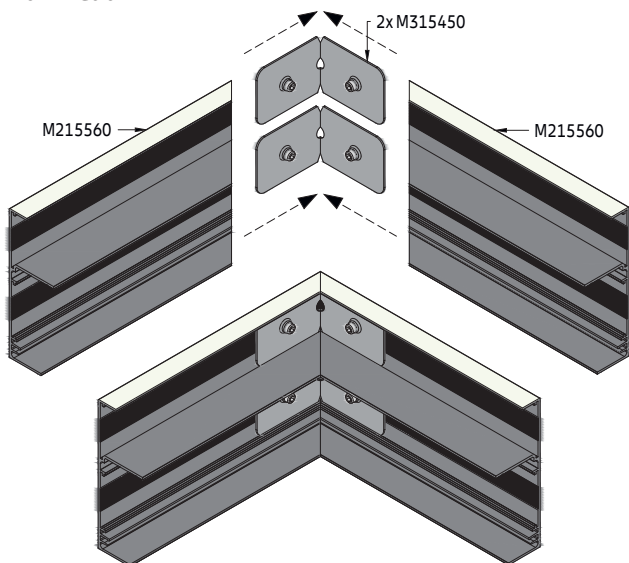

Bulkhead 6"

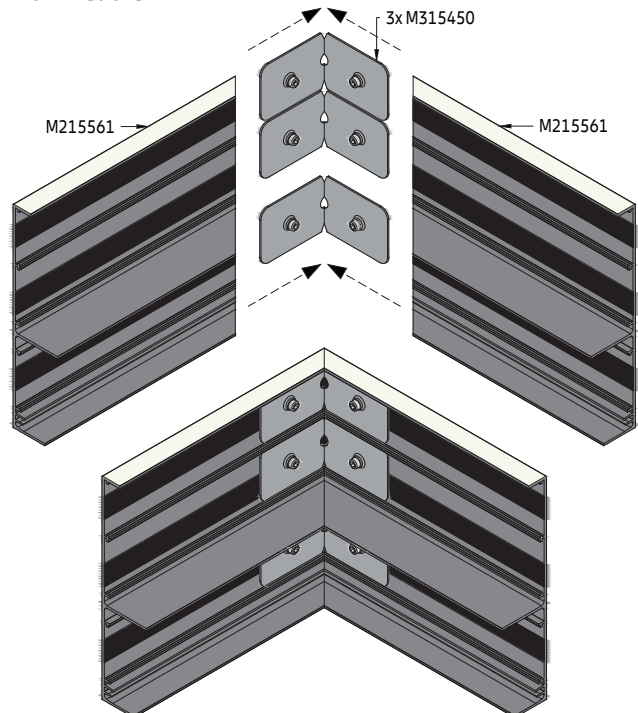

METAL Aluminium Bulkhead Solutions
T02.003

Detail F

Bulkhead connection to U-Profile

The perimeter profile was developed so that the ceiling does not connect to the wall and an open shadow gap is visible. The distance from the wall is variable.

The perimeter profile can be used in two ways. Option 1 for a simple square edge, option 2 for a 10 x 15 mm step finish.

The perimeter profile is attached to the U-profile with an M6 bolt. Measure the required a1 distances and mark the position of the hole. A Ø7 mm hole must be drilled into the perimeter profile.

The U-profile is attached with two washers at a distance of 3 mm from the perimeter profile. This results in a height of 98 mm for the most common metal systems.

Depending on visibility, the U-Profile can be cut off at 45° at the ends. In option 1, the perimeter profile is compatible with the RA 4 F and RA 9 F perimeter trim.

As with the perimeter trims, a pressure spring can be used to hold down the cut tile / panels.

Perimeter profile - option 1

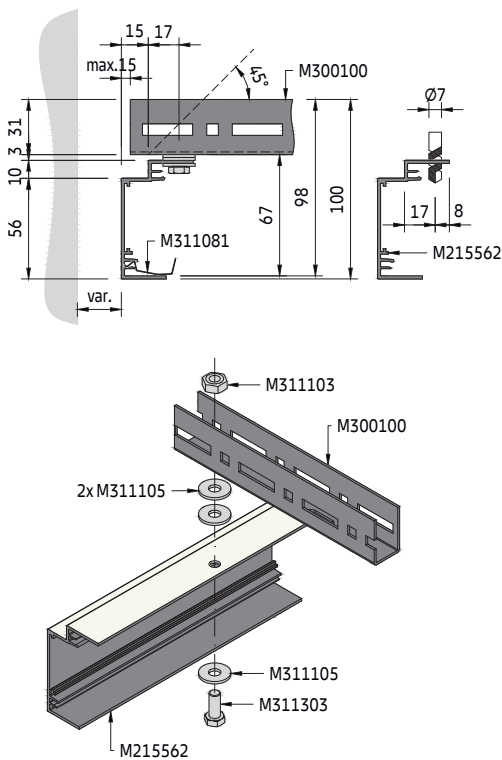

Perimeter profile - option 2

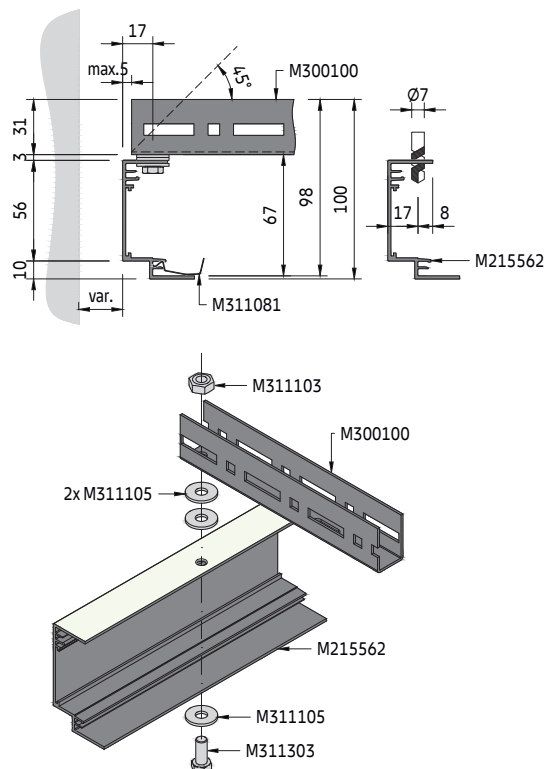

METAL Aluminium Bulkhead Solutions

T02.003

The bulkhead 4" and 6" were developed to completely cover the U-profile primary grid system.

These solutions are suitable as a simple bulkhead detail or large size canopies with standard ceiling systems.

The bulkhead is attached to the U-profile with an M6 nut and bolt. Measure the required a1 distances and mark the position of the hole. A $\varnothing 7$ mm hole must be drilled into the bulkhead.

The bulkheads are compatible with the RA 4 F and RA 9 F perimeter trim.

As with the perimeter trims, a pressure spring can be used to hold down the cut tile / panels.

Bulkhead 4"

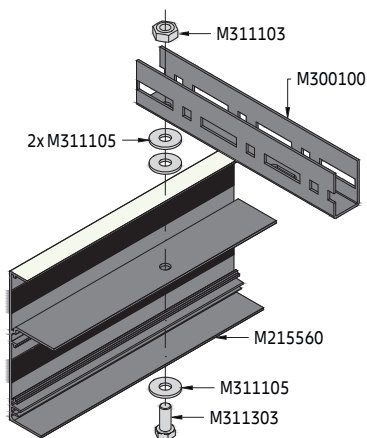
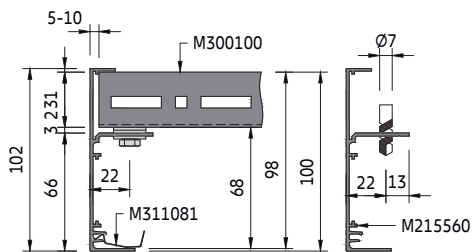

Bulkhead 6"

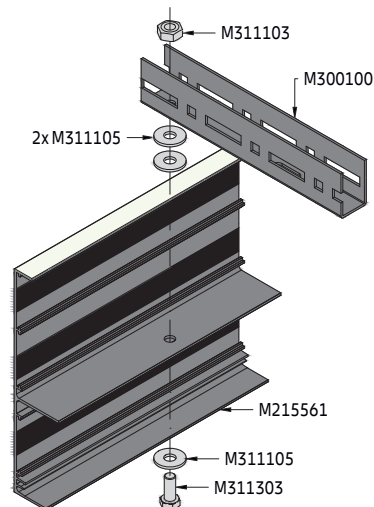
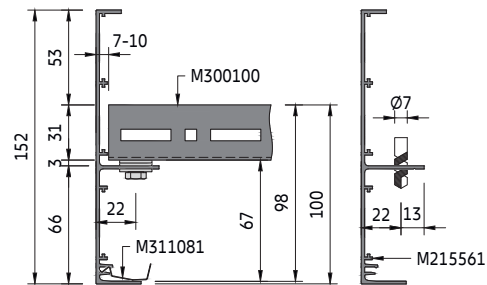

Detail G

Suspension options

Option G1

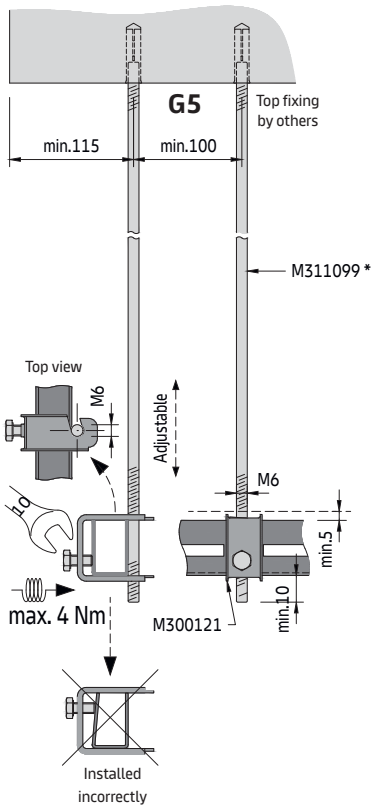

Option G2

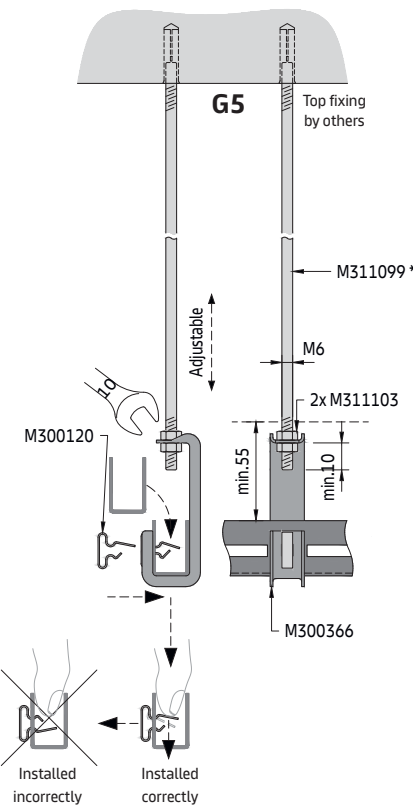

Option G3

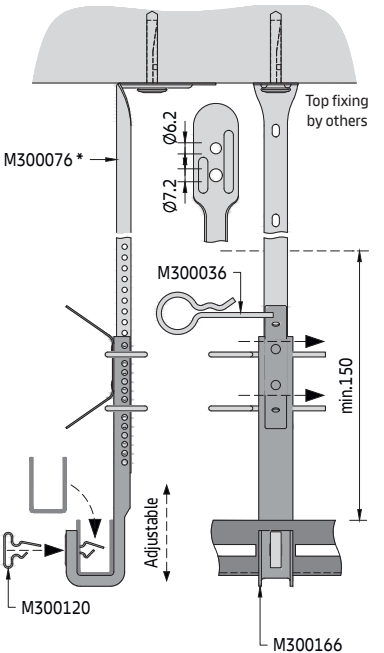

Option G4

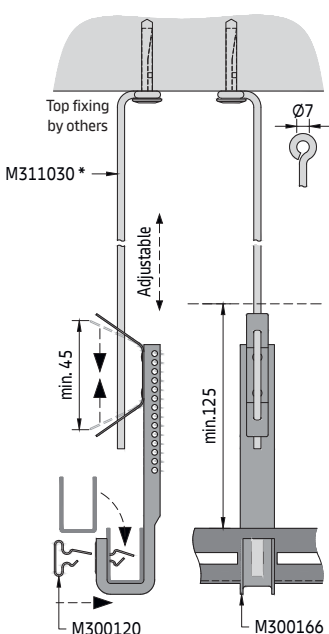

Detail G5

Optional top fixing and extension detail for suspension option G1 / G2

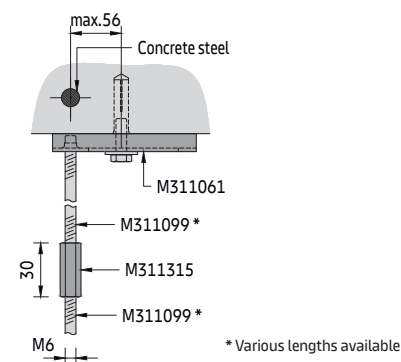

The suspension point should always be chosen close to the crossing point of the primary and secondary grid in order to absorb the ceiling load as best as possible and to prevent the U-profile from potentially deflecting.

METAL Aluminium Bulkhead Solutions

T02.003

Detail H

Change in level

Perimeter profile - option 1 with RA 4 F and RA 5 F perimeter trim

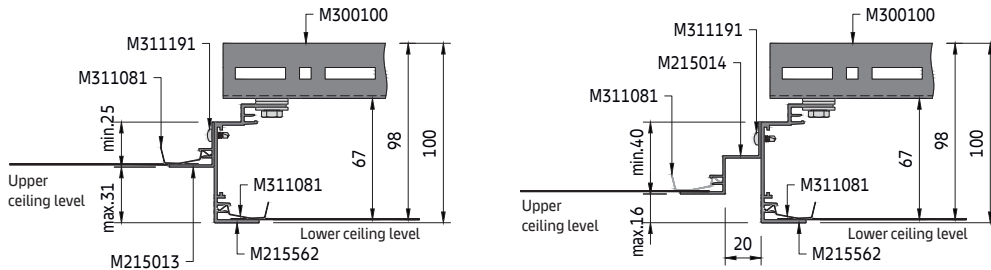

Perimeter profile - option 2 with RA 4 F and RA 5 F perimeter trim

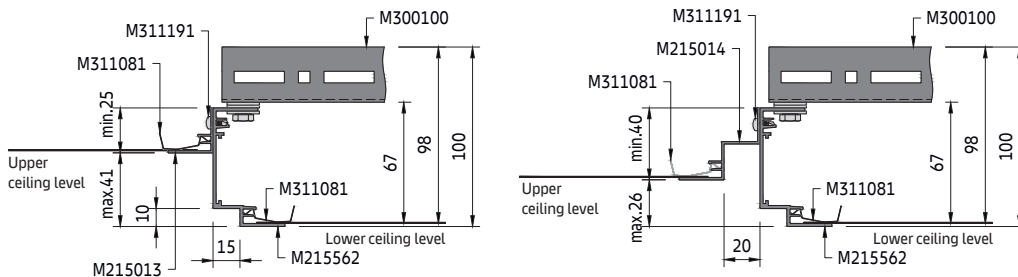

Bulkhead 4" with RA 4 F and RA 5 F perimeter trim

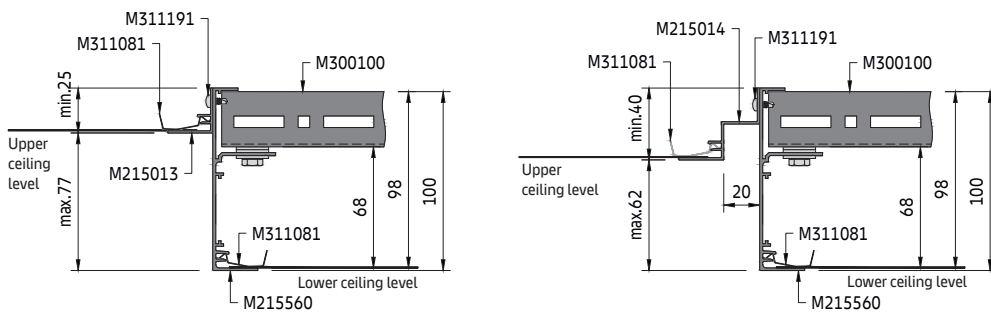

Bulkhead 6" with RA 4 F and RA 5 F perimeter trim

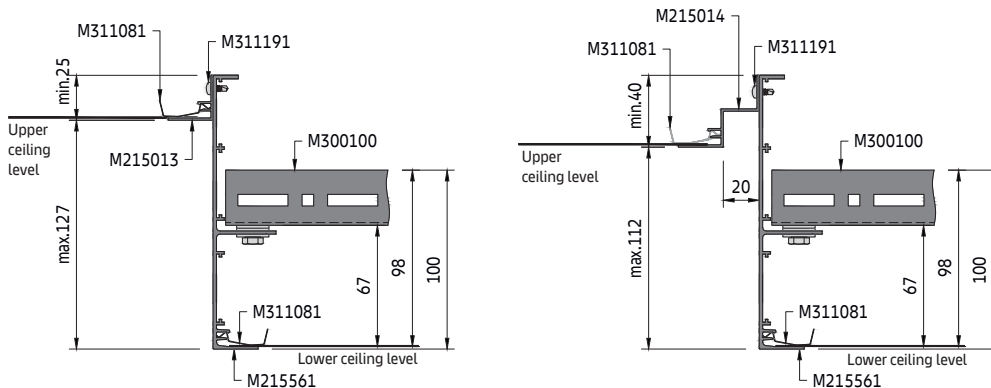

For higher changes in level see steel bulkheads datasheet. Further perimeter solutions see separate datasheet.





Cutting & Modifications

METAL Cutting & Modifications

Cutting

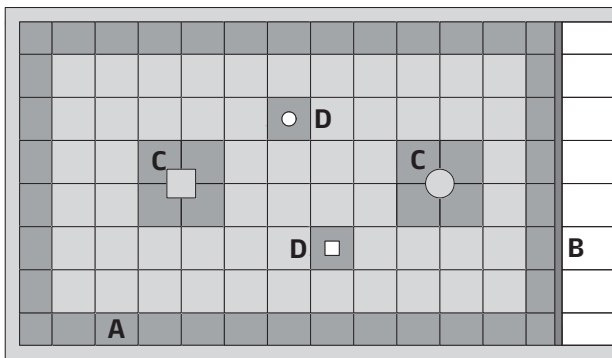

Detail A - Perimeter

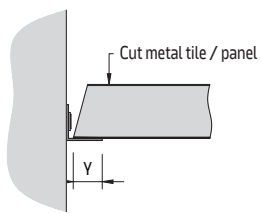

Detail B - Transitions (example with L-Profile)

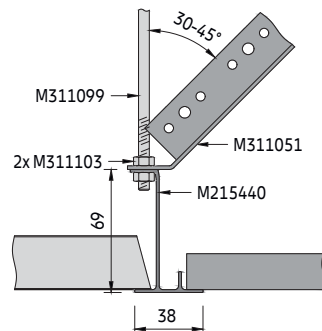

Detail C - Columns

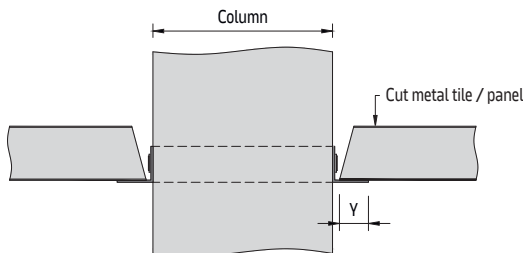

Detail D - Service integrations

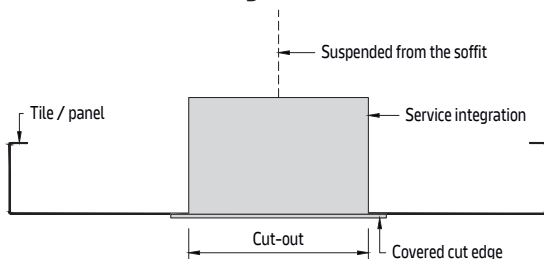

General

Cuts are usually required in the perimeter area (detail A), for transitions (detail B), columns (detail C) and cut-outs (detail D) for service integrations. The cut edges are covered by a profile or trim and should not be exposed. A little practice is required for clean and precise cuts, especially for delicate work and tight curves. It is best to try out a few practice pieces beforehand to avoid unnecessary waste. Wear white gloves to avoid leaving fingerprints on the surface of the tiles/panels. Be careful when cutting sheet metal, as there is a risk of injury from the sharp cutting edges.

Tiles / panels

When cutting, the visible side of the tiles / panels should face up to avoid scratching. Measure the distances precisely and transfer the cutting line on the tile / panel. The minimum contact surface (Y) depends on the selected trim (see perimeter trims). It is imperative that this value is adhered to, as otherwise it is possible to fall down and cause personal injury. For tiles with Premium infills, a jigsaw or saw should be used that cuts carefully and not damages the sheet metal and infill.

Baffles

Due to the fact that the raw edges remain visible, on-site trimming of baffles is not recommended. In most cases the result will not be appealing.

Profiles / trims

Profiles can be cut with a saw. Visible components, as with tiles/panels, care should be taken not to scratch or damage the visible side.

Service integrations

Generally, additional loads need to be supported with additional hangers from the soffit (detail D). Loading the tiles is not permitted. The service integrations should not affect the visual appearance of the tiles / panels, i.e. no greater sag or stress on the surface. Small service integrations, such as for example smoke detectors, with little weight are the exception, but must be approved from customer side after installation. Round and square cut-outs are to be made in the dimensions specified by the supplier of the service integration. Tiles / panels can be supplied with factory cut-outs upon customer request. See METAL general information pages for options. Ventilation components can leave residues on the surface by sucking in the air, which contaminate them. See cleaning and maintenance chapter.

METAL Cutting & Modifications

U02

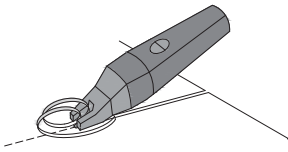
Tools**Nibbler**

If available, the use of a nibbler is recommended for cutting tiles and panels, with or without an acoustic fleece. A narrow strip is nibbled out in progressively cut small sections of the metal sheet, emission and spark free. The nibbler is suitable for effortless cutting of straight as well as curved contours at the perimeter and cut-outs for service integrations. This allows standard steel and aluminum elements to be cut to size with a material thickness of up to 1.0 mm. This tool is suitable for both beginners and advanced users. It is easy to use and requires little effort, preventing the sheet metal from being deformed unintentionally. With the right speed and power, cutting is easy. The variant with a battery and no cable is particularly suitable for mobile use on construction sites.

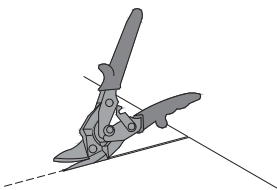
**Tin snips**

Tin snips can be used to cut tiles and panels if a nibbler is not available. There are different types of tin snips, for different applications. Tin snips work like normal household scissors, but require greater effort due to the hardness of the metal sheet. Tin snips are not suitable for beginners, as manual cutting can cause the sheet metal to buckle very quickly. Furthermore, thin-walled profiles (T-Grid, perimeter trims, etc.) can also be cut to length. It is used primarily for butt cuts, but only suitable for mitre cuts to a limited extent. Generally, use is limited to tiles, panels and profiles with a gauge of max. 0.7 mm. For an optimal result, the sheet metal must be placed on the cutting jaw of the tin snips, otherwise it will warp. The tin snips should be opened wide and the sheet metal should be pushed deep into the mouth. It is important not to close the scissors completely when cutting, but to open them again after $\frac{3}{4}$ of the cutting length and push the material further. Otherwise unsightly transverse cracks will appear.

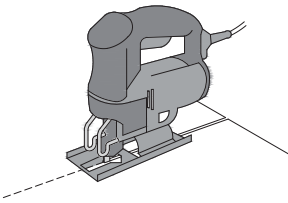
**Jigsaw**

Tiles with premium infills can be cut with the jigsaw. The variant with a battery and no cable is particularly suitable for mobile use on construction sites.

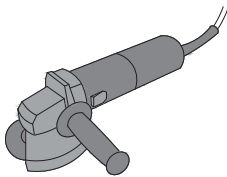
**Angle grinder**

This is only suitable to a limited extent due to the heat development and the resultant discoloration of the metal. When using angle grinders, particularly for large material thicknesses of ≥ 1.0 mm, the heat development can be reduced by using suitable thin separation sheets, 1.0 mm thick. Even then, proceed with care.

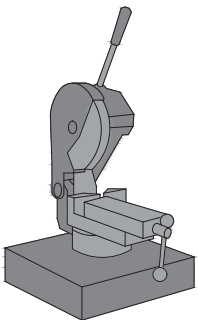
**Mitre saw**

The use of a metal-mitre saw delivers by far the best results for butt and mitre cuts. Proceeding with care (low cutting speed) is also essential. Avoid damaging the surface with metal cuttings. When cutting shadow trims it is advantageous to use a suitable wooden batten underlay.

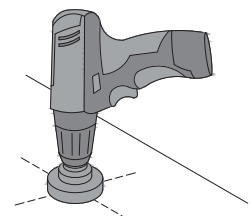
**Drilling machine**

A power drill can be used for small circular cutouts. Larger round cutouts can be made with a hole saw attachment.

Service integrations

Without weight distribution clip

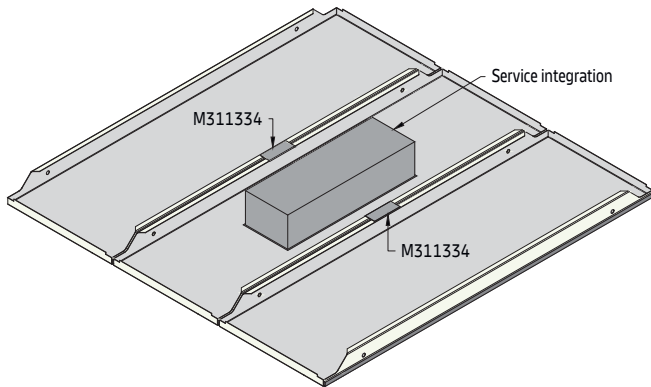

With weight distribution clip

**Weight distribution clip**

For service integrations with little weight, a weight distribution clip can be used per long side. The additional load in the panel is distributed to the neighboring panels. Without it, the increased sag (X) might at best be visible. The clips are placed over the long side edges of the panels.

This solution was developed for lay-in or hook-on rectangular panel solutions for corridors and rooms. It is not recommended to use this for clip-in systems.

There is no fixed basic rule or weight specification, as various parameters have to be taken into account. These are primarily the additional weight of the service integration, the length and width of the panel, the material gauge, perforation, etc.

The application must be checked and approved on a case-by-case basis.

METAL Cutting & Modifications

U02

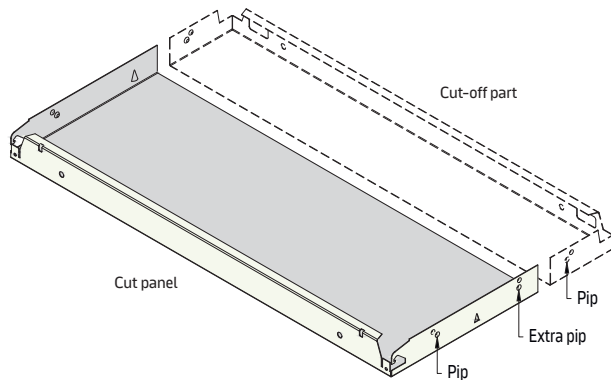
Modifications**Example with METAL R-Clip****Nubby pliers**

In order to be able to install a clip-in tile / panel, four pips per module are required. Normally, the cutting edge lies on a profile or trim, so only two pips are needed. In individual cases it can happen that additional pips are required because the original pips had to be cut away. In these cases, the nubby pliers M311180 are used.

1. Pick the location of the extra pips.
2. The pliers are inserted as far as they will go over the upstand from the rear. Squeeze the pliers to indent the pips.
3. The tile / panel can now be installed.

The pliers can be used with the following products:

- METAL Q-Clip
- METAL Q-Clip F
- METAL R-Clip
- METAL K-Clip
- METAL F-Clip

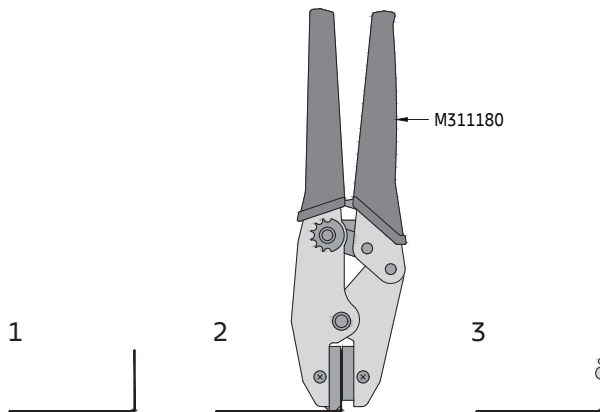

1.06.01
responsável ANL

1.06.02
macroelementos I

1.06.03
macroelementos II

1.06.04
metais - espectrometria de massa

1.06.05
metais - absorção atômica

1.06.06
metais - espectrometria de emissão

1.06.07
metais - preparação de amostras

1.06.08
parâmetros físico químicos

1.06.09
parâmetros complementares

1.06.10
preparação de material

1.06.11
balanças

1.06.12
matrizes complementares - preparação de material

1.06.13
matrizes complementares - parâmetros físico químicos

1.06.14
metais - matrizes complementares

1.06.15
COT/NT

1.03.01
coordenação QI



zona 06

química inorgânica



ca

Maintenance & Cleaning

METAL Maintenance & Cleaning

Maintenance

Access to the ceiling void

In general, all standard and configurable products can be removed individually. This is necessary to ensure maintenance work on the building services.

Extract the elements with care and store them in a place where they will not be damaged during the maintenance work. The products should be stored upright. No additional weight should be placed on it.

If the product has a gasket then it should not be stored on it. Various hinge-down and swing-down solutions are available to facilitate access. This function can either be applied to all panels or individual elements. If desired, these can be marked on site to identify them. This is done by the installer or the person who will later be responsible for maintenance.

Extraction tools

There are systems where a tool is required to extract or unlock the element. Choosing the right tool is crucial and prevents damage to the product. The correct tool is specified in the Knauf Ceiling Solutions installation manual. Make sure not to damage the product when using the tool. This can be a deformation of the edge, scratches on the surface or damage to the gasket.

Gasket

If the tools are used more frequently on the same product, it could happen that the gasket has to be replaced due to heavy wear. If the room climate does not meet the specifications, the gasket can be damaged or detach from the element.

Rolls can be reordered separately and attached to the product on site. The damaged gasket should first be carefully removed without damaging the product. Then reattach the new gasket in the same place.

Security clips & brackets

Individual tile access is not given when using security clips and brackets. If the entire ceiling gets locked, the modules have to be dismantled from the last one that was not secured.

Individual elements can also be locked, e.g. to protect service integrations from being damaged by attempts to remove them. Use systems like METAL R-H 200, METAL R-H 215 and METAL R-H 220 (for Swiss market only) that use clips that can be locked / unlocked from below.

Instructions

The person responsible for building maintenance should receive detailed instructions and have access to a tool where needed. Extraction tools are offered by Knauf Ceiling Solutions.

Cleaning

General

Knauf Ceiling Solutions metal ceilings and walls are available with different surface finishes, patterns and acoustic infills, of which the visible face can be cleaned using a variety of types and methods.

The visible surface is electrostatically powder-coated as standard and is highly durable. There are exceptions where products are made out of pre-coated material. The types of cleaning shown here may not be applicable to these products. These products are identified in our literature. Whenever the coated elements are touched, this should always be done with soft white gloves, otherwise fingerprints and staining will be left on the surface, which makes cleaning more time consuming.

Normally, ceiling and wall components do not need to be cleaned for the duration of their use in most standard applications. Nevertheless, it may be necessary to clean local soiling frequently to maintain their appearance. This is not necessary for functional reasons to maintain the fitness for use over the entire service life.

The frequency of cleaning will depend on the type and efficiency of the heating, ventilation and air conditioning system within the building and the type of occupancy. This can only be determined after the building is occupied. The mechanical stresses of cleaning (scrubbing) may lead to changes to the surface. Do not apply excessive pressure to the surface as this may deform or damage it.

Highly adhesive dirt (grease, oils, acids and bases) can be resistant to cleaning and can affect the surface permanently. If this cannot be removed by normal washing, then a small application of thinners can be used on the stain. However, care should be taken as this could affect the gloss level of the coated finish. It is recommended to test the proposed cleaning method on a sample piece or a non-visible part of the ceiling. The cleaning should also be carried out over a large area and not limited to individual tiles or small areas.

METAL Maintenance & Cleaning

V02

High levels of moisture exposure due to regular cleaning or room climate conditions may cause increased corrosion protection requirements with regard to the substructure and the attachment.

Additional measures must be taken into account if the suspended ceiling is subject to pressure.

Resistance to solvents

Coated surfaces get softened or swollen within minutes or hours by organic solvents. Changes in the degree of gloss are possible. Generally, coated surfaces are moderately or poorly resistant to organic solvents. Fuel can also strongly attack powder-coated surfaces.

Resistance to water-based acids, alkalis, salts

Coated surfaces are highly resistant against purely water-based chemicals. Even by lack of wetting they scarcely get attacked by strong acids and alkaline solution. Strong oxidisers may change the color or even discolor. Preservatives, detergents, disinfectants - if solvent-based, can attack the surface.

Resistance to colorants

Colorants from red wine, tea, coffee, inks, berries and similar substances can migrate into the coating layer and stay permanently. It does not attack or damage the surface. These resistances are difficult to predict and should always be checked case by case.

Recommendations

- The surface temperature of the coated elements should not exceed 25°C during the cleaning.
- Only use clean and pure water with slight additions of neutral or weakly alkaline detergents. With metallic coatings use only neutral cleaners.
- Do not use abrasive, scratching products, e.g. sanding pastes. Strong rubbing is prohibited.
- Do not use organic solvents containing ketones, esters, aromatics, halogenated hydrocarbons, etheric oils or similar.
- Do not use acids or high alkalic products.
- The action time of the products used should not exceed one hour.
- If the cleaning process has to be repeated, a 24 hours waiting period has to be observed.

METAL BioGuard products

Metal BioGuard is more effective in the control of bacteria than a standard powder coating because it prevents the settlement of bacteria on the surface of the product. It gives good cleanability and resistance to disinfectants. For more information, please get in touch with us.

METAL Maintenance & Cleaning

V02

**Dry cleaning**

- Daily cleaning of all metal products

For standard cleaning of dust, loose dirt or deposit, a soft brush, a clean, dry, soft white cloth, a normal vacuum cleaner with a soft brush can be used.

**Damp cleaning**

- Daily cleaning of unperforated / perforated up to Ø1.0 mm surfaces
- Weekly cleaning of perforated surfaces >Ø1.0 mm

For more intensive cleaning, the surfaces can be damp cleaned. This should be carried out with a wrung-out soft cloth or sponge. After cleaning, the surface should be dried with a soft cloth.

**Wet cleaning**

- Daily cleaning of unperforated / perforated up to Ø1.0 mm surfaces
- Weekly cleaning of perforated surfaces >Ø1.0 mm

Wet cleaning should be carried out with lukewarm water (up to 40°C), using a sponge and mild cleaning agent (with a pH value between 7 and 9). It is important that the edges and the reverse side of the tile do not come into contact with moisture. After cleaning the surface should be dried with a soft cloth.

**Focussed compressed air cleaning**

- Daily cleaning of TrioGuard coated surfaces

The surface can be cleaned using focus compressed air. The apparatus used should be a cleaner that generates steam under pressure (8 bar and 175°C).

**Pressure cleaning**

- Twice yearly cleaning of unperforated surfaces

Pressure cleaning (no steam) is carried out with the following technical restrictions:

- Water temperature: max. 40°C
 - Working pressure: max. 80 bar, flow rate max. 500 l/h
 - Minimum distance to surface: 1.0 m
- Penetration of water into the suspension system should be avoided. Following cleaning, the surface should be dried.

**Resistance to popular disinfectants**

- Daily cleaning of unperforated / perforated up to Ø1.0 mm surfaces
- Weekly cleaning of perforated surfaces >Ø1.0 mm

Due to large number of types of disinfectants, always test a small area first.



Custom METAL Solutions

West Styria (Weststeiermark) Railway Station, Groß Sankt Florian, Austria

© pierer.net

Build on us.

Knauf Ceilings Holding GmbH
Landshuter Allee 10
80637 Munich, Germany

Phone: +49 9323 31-0

E-mail: zentrale@knauf.com

www.knauf.com

Commercial Register: Munich, HRB 306247

VAT No. pursuant to § 27a of the German VAT Act
(Umsatzsteuergesetz): DE317846056

Board of Directors: Lars Klodwig, Karl Wenig,
Daniel Wolf

EN - 11/2025

nicht in
enthalten

Gesamt e Manuals

METAL S-Clip F

U-Profile primary grid + DP12 A-Bar secondary grid
Concealed grid solution for indoor applications

General information

- Concealed clip-in grid system for small and medium rooms
- For perpendicular installation on U-Profile primary grid
- DP12 A-Bar made of galvanised steel
- Typical ceiling weight 5.0 - 5.5 kg/m² (indicative value for unperforated panels / tiles, without additional load)
- Tiles are easily installed and fully demountable
- Included swing-down function

Isometric view

Select the suspension option E1 - E4.
Perimeter solutions on separate datasheet.

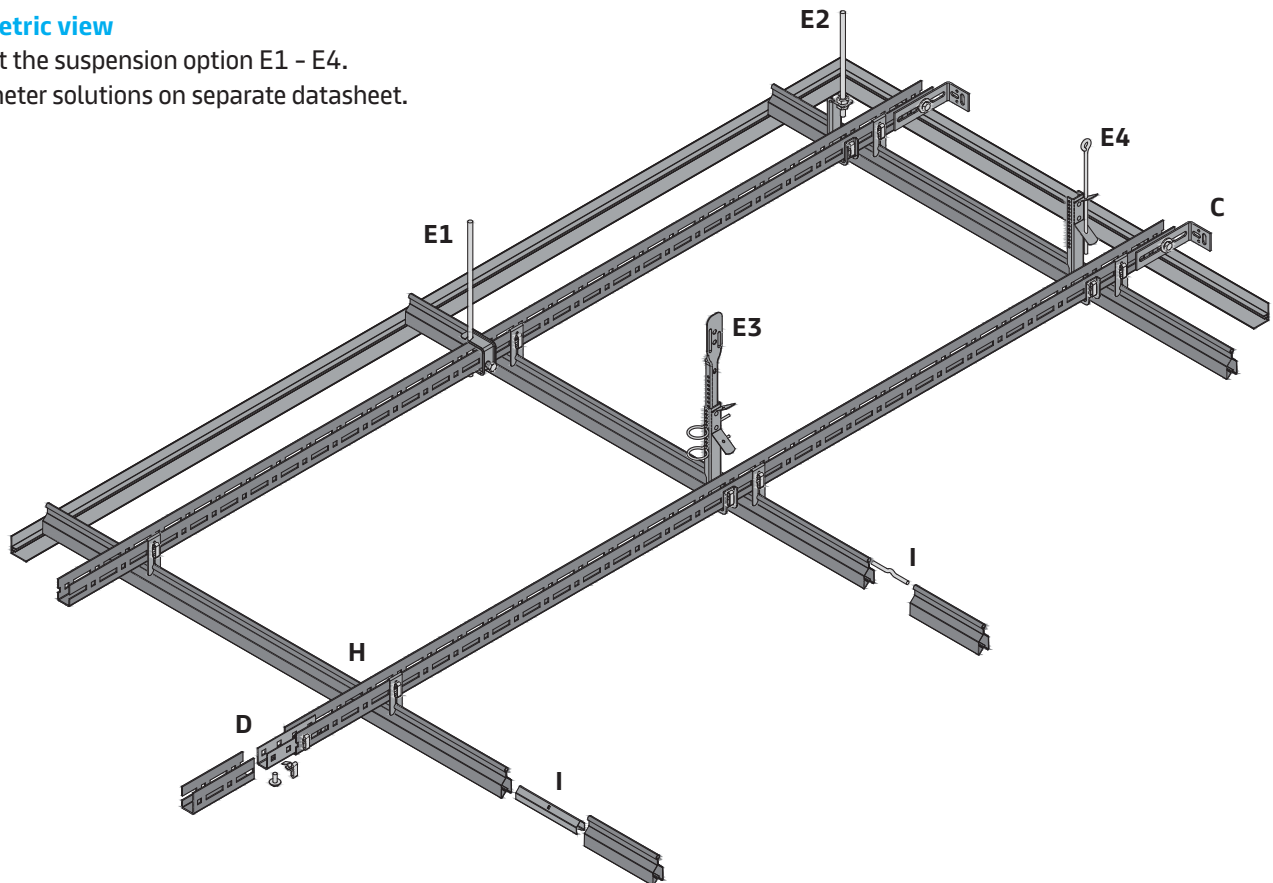

Standard layout options

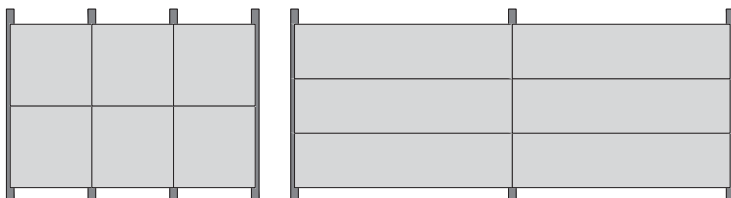

Section F

Example with suspension option E1

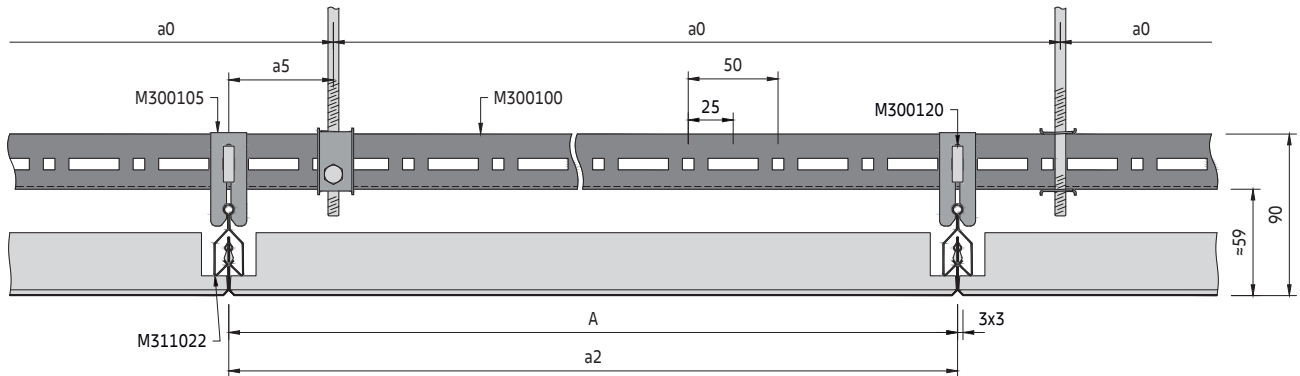

Section G

Example with suspension option E1

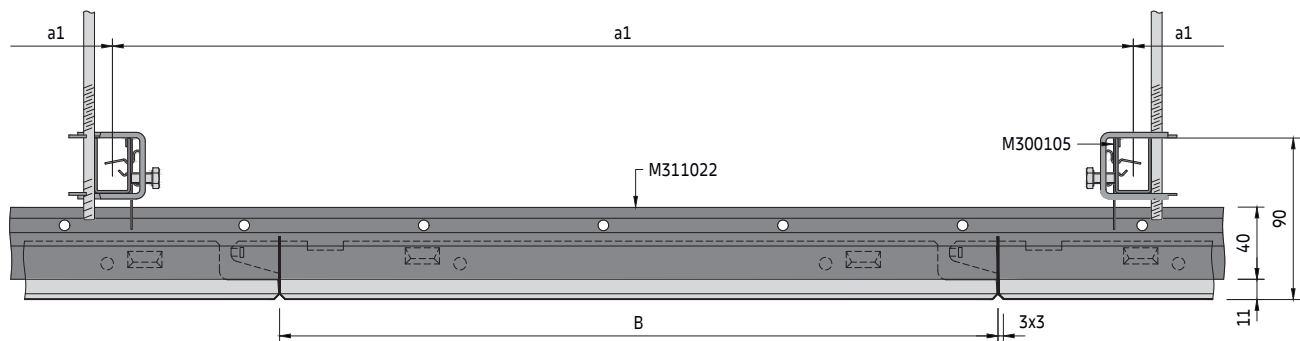

Secondary grid components

Standard components

- M311022 DP12 A-Bar
- M300138 Connection pin for DP12 A-Bar
- M300105 Hanger for DP12 A-Bar
- M300120 Plug-in clip for U-Profile

Optional components

- M311023 Splice connector for DP12 A-Bar
- M311046 Extraction tool
- M311191 Self-drilling screw 3.5 x 9.5 mm

See U-Profile primary grid for primary grid components

DP12 A-Bar secondary grid

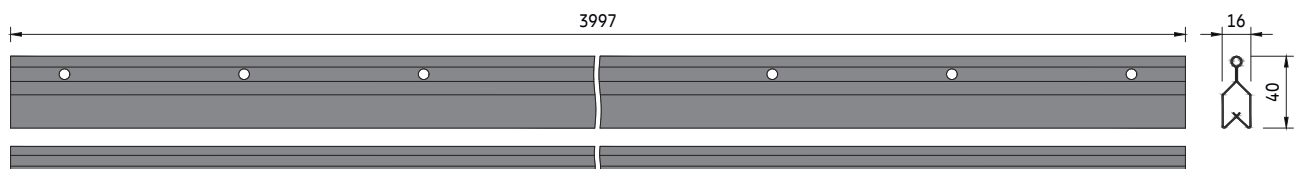

Spacing

a2 [mm]	System without additional load		System with additional load +4 kg/m ²	
	a0 [mm]	a1 [mm]	a0 [mm]	a1 [mm]
600	1200	1900	1200	1700
625	1250	1850	1250	1550
900	900	1550	900	1400
1200	1200	1350	1200	1250
1500	1500	1250	1500	1100

To determine suspension layout

The module length (M) of the requested ceiling is equal to the distance between the DP12 A-Bar centres (a2).

On the appropriate spacing table, read down the column headed (a2) to the required module length then read across to determine the suspension point spacing (a0) and U-Profile spacing (a1).

The shown values are maximum allowed distances and can be reduced but not exceeded.

Parameters

- a0 Distance between U-Profile suspension points = max. 1900 mm
- a1 Max. distance between U-Profiles
- a2 Distance between DP12 A-Bars = tile / panel length
- a3 Distance from wall = max. 200 mm
- a4 Distance from wall = max. tile length
- a5 Distance from U-Profile suspension point to hanger = max. 100 mm
- M Module size = tile length / tile width 600 x 600, 625 x 625, 900 x 300, 1200 x 300, 1500 x 300 mm

Typical grid layout

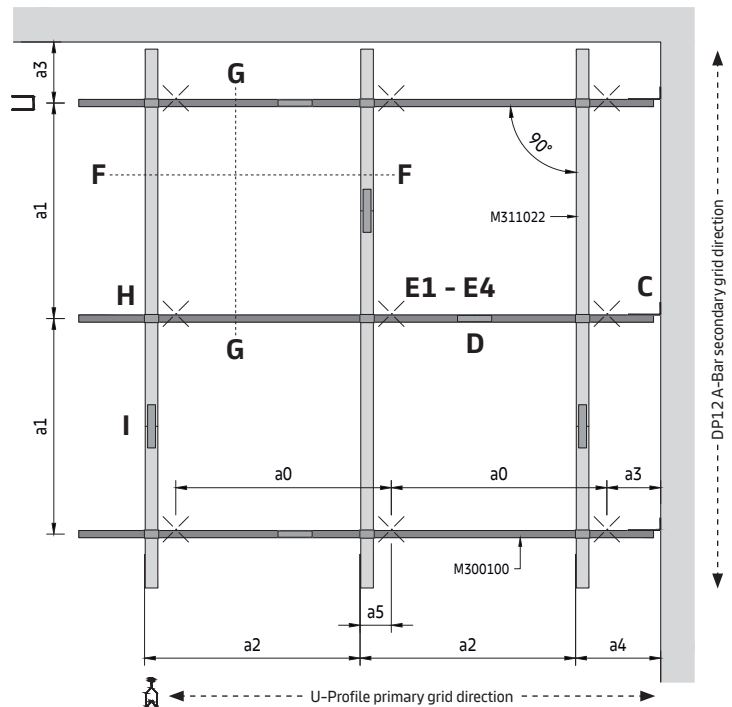

Detail H

Hanger installation

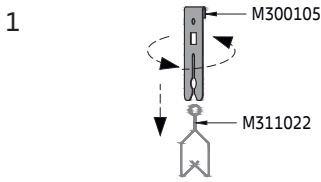

The hanger for DP12 A-Bar is made of spring steel and is therefore elastic. It is twisted on the DP12 A-Bar from above. Then it can be slid to the correct position.

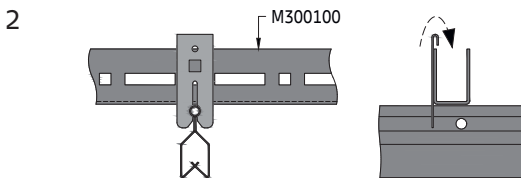

Hang the DP12 A-Bar with the hangers under the U-Profile.

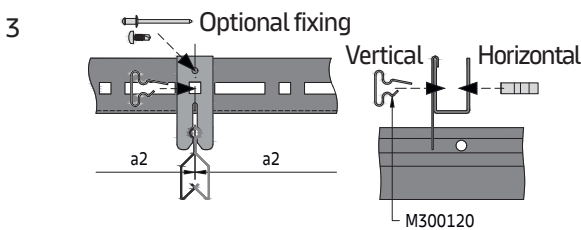

Fix hanger with plug-in clips at the specified module spacing (inserted vertically or horizontally). If the panel size does not fit with the modulation of the U-Profile (25 mm increments), the plug-in clip needs to be inserted into a long hole. The hanger position can alternatively be fixed by using a pop-rivet or self-drilling screw.

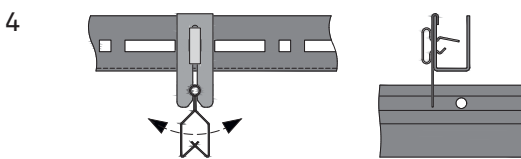

The DP12 A-Bar is now locked in position. Due to the round head of the DP12 A-Bar, it can swing. This is important, because it allows any tolerances to be compensated. Otherwise the tiles could no longer be inserted after a certain point.

Detail I

Splice connection

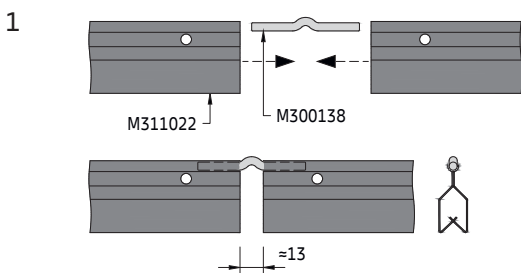

Insert the connection pin at the ends of the DP12 A-Bars and connect them. There is a gap between the DP12 A-Bars. The DP12 A-Bars must be aligned so that the joint is not in the same place as the pips on the tiles.

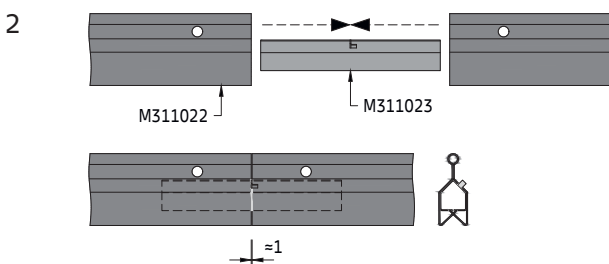

Optionally, the splice connector for DP12 A-Bar can be used. This is inserted at the ends of the DP12 A-Bars and an almost seamless connection is created.

Detail J

Tile insertion

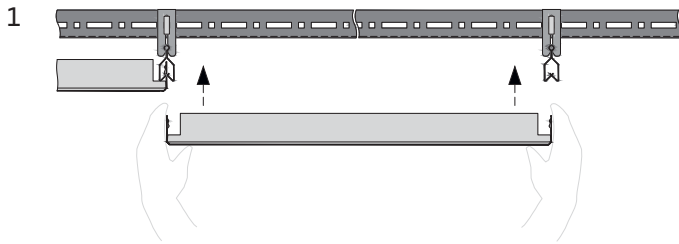

Take the tile and carefully insert it into the DP12 A-Bars from below. Care is required when installing tiles. Always press along the edges with the pips and never on the transverse sides, otherwise the tile may be damaged. The tiles can only be laid in the same direction.

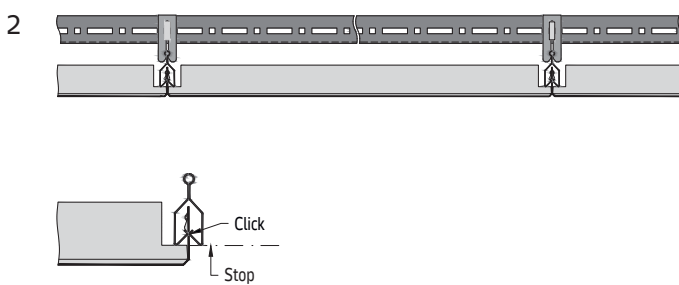

The tiles are correctly inserted when all four corners are flush with the neighbouring tiles. The tiles are designed to match the DP12 A-Bar. If third party profiles are used there is a high probability the tiles will not be correctly inserted.

Tile extraction

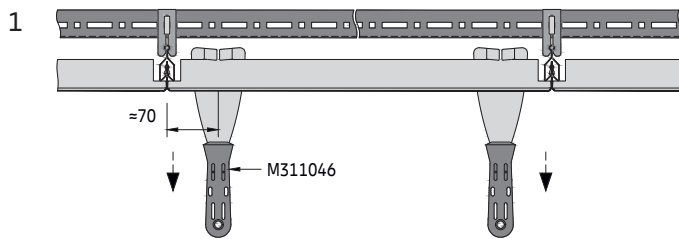

Insert the extraction tool on one side first and pull down with a gentle tug, followed by the opposite side.

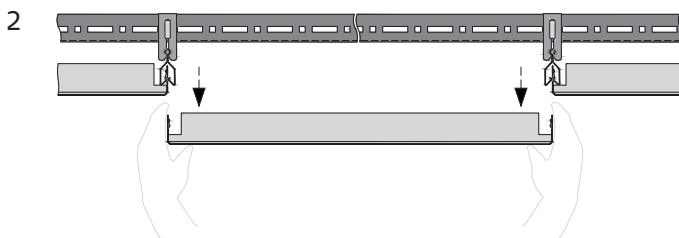

Remove it downwards and store the tile in a safe place so that it cannot be damaged.

Detail K

Included swing-down function

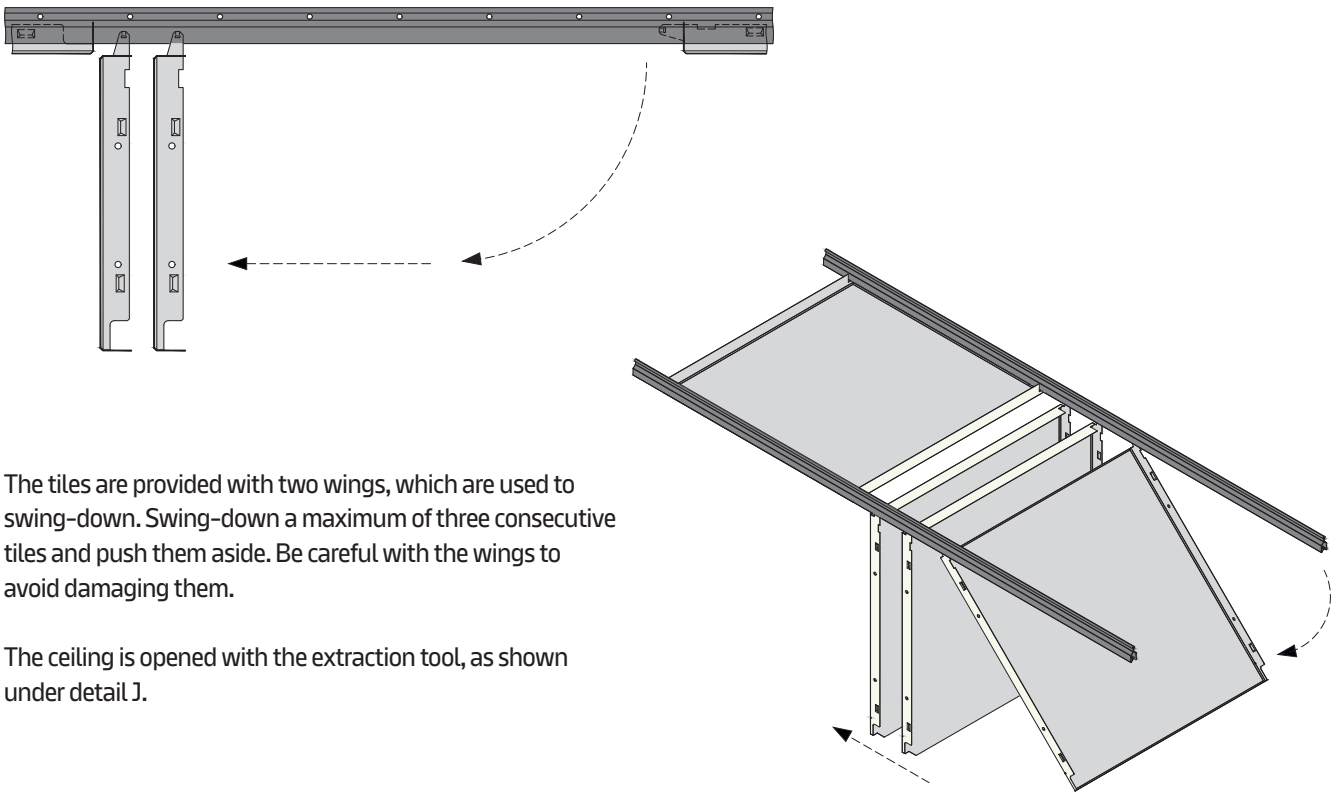

The tiles are provided with two wings, which are used to swing-down. Swing-down a maximum of three consecutive tiles and push them aside. Be careful with the wings to avoid damaging them.

The ceiling is opened with the extraction tool, as shown under detail J.

Material required per m² (no waste included)

System without additional load [pcs/m²]

Components		a2 [mm]	600	625	900	1200	1500
M300100	U-Profile		0.14	0.15	0.17	0.20	0.21
M300105	Hanger for DP12 A-Bar		0.88	0.87	0.72	0.62	0.54
M300119	Splice connector for U-Profile		0.15	0.15	0.18	0.20	0.22
M300120	Plug-in clip for U-Profile		1.28	1.17	1.08	1.02	0.98
M300138	Connection pin for DP12 A-Bar		0.42	0.40	0.28	0.21	0.17
M300140	Wall anchor		0.06	0.06	0.07	0.08	0.09
M311022	DP12 A-Bar		0.42	0.40	0.28	0.21	0.17
M311103	Hexagonal nut M6		0.10	0.10	0.10	0.10	0.10
M311105	Washer		0.10	0.10	0.10	0.10	0.10
M311303	Hexagonal bolt M6 x 16 mm		0.10	0.10	0.10	0.10	0.10
Various	Suspension points (E1 - E4)		0.44	0.44	0.72	0.62	0.54

The shown quantities are theoretical and based on an ideal layout, without considering the actual room layout. The ideal layout is based on a calculation of 10 x 10 m (100 m²). This calculation does not allow any damage, spare nor wastage. The final quantities and type of suspension have to be checked before ordering. Soffit and wall fixings by others. Not including perimeter trims and extraction tools.

METAL S-Clip F

DP12 A-Bar primary grid + DP12 A-Bar secondary grid
Concealed grid solution for indoor applications

General information

- Concealed clip-in grid system for small and medium rooms
- For perpendicular installation on DP12 A-Bar primary grid
- DP12 A-Bar made of galvanised steel
- Typical ceiling weight 5.0 - 5.5 kg/m² (indicative value for unperforated panels / tiles, without additional load)
- Tiles are easily installed and fully demountable
- Included swing-down function

Isometric view

Select the suspension option D1 - D2.
Perimeter solutions on separate datasheet.

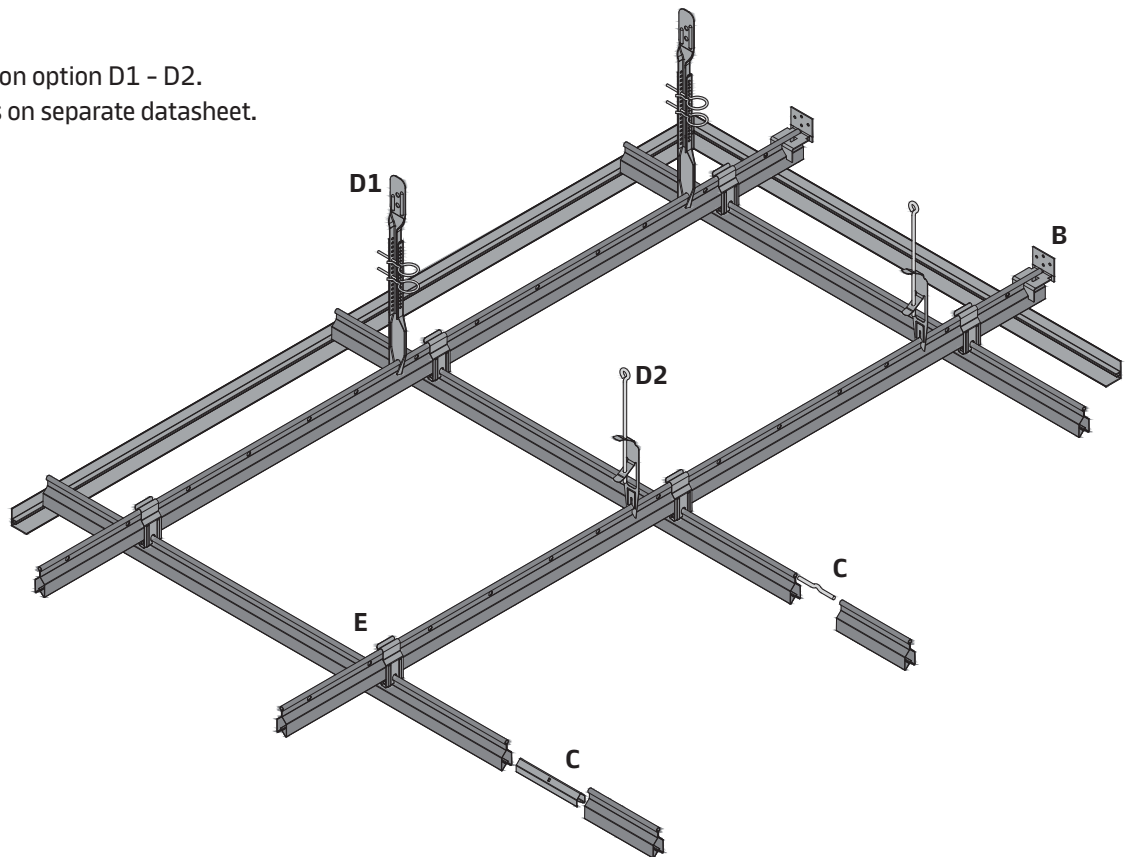

Standard layout options

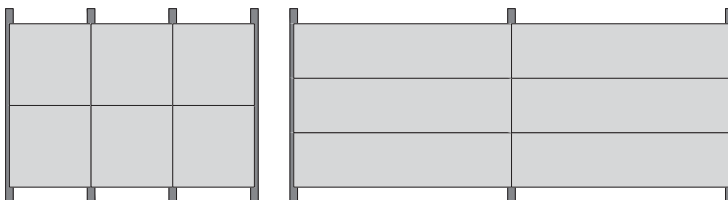

Section F

Example with suspension option D2

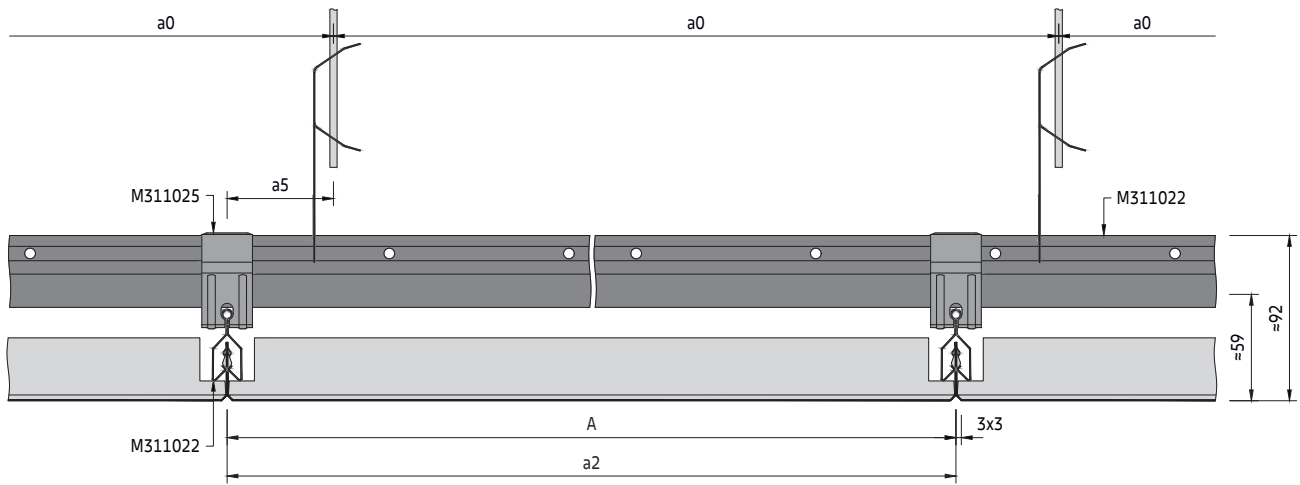

Section G

Example with suspension option D2

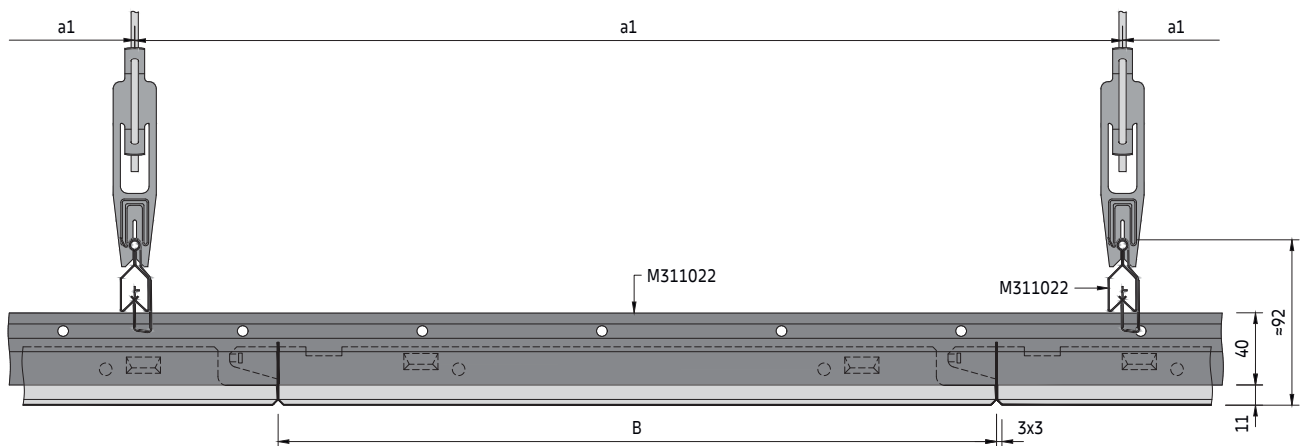

Secondary grid components

Standard components

- M311022 DP12 A-Bar
- M300138 Connection pin for DP12 A-Bar
- M311025 Cross connector for DP12 A-Bar

Optional components

- M311023 Splice connector for DP12 A-Bar
- M311046 Extraction tool

See DP12 A-Bar primary grid for primary grid components

DP12 A-Bar secondary grid

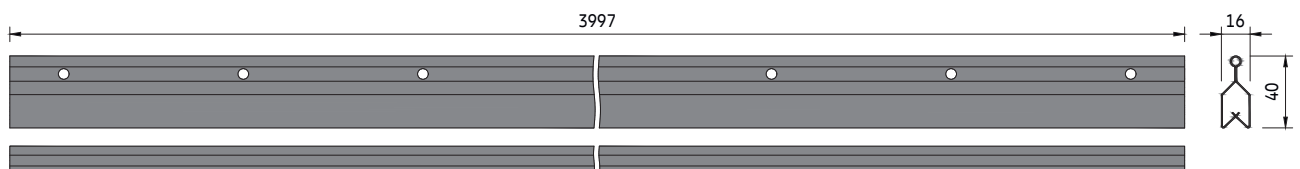

Spacing

a2 [mm]	System without additional load		System with additional load +4 kg/m ²	
	a0 [mm]	a1 [mm]	a0 [mm]	a1 [mm]
600	1200	1900	1200	1700
625	1250	1850	1250	1450
900	900	1550	900	1400
1200	1200	1350	1200	1250
1500	1500	1250	1500	1100

To determine suspension layout

The module length (M) of the requested ceiling is equal to the distance between the DP12 A-Bar centres (a2).

On the appropriate spacing table, read down the column headed (a2) to the required module length then read across to determine the suspension point spacing (a0) and DP12 A-Bar spacing (a1).

The shown values are maximum allowed distances and can be reduced but not exceeded.

Parameters

- a0 Distance between DP12 A-Bar suspension points = max. 1900 mm
- a1 Max. distance between DP12 A-Bars
- a2 Distance between DP12 A-Bars = tile / panel length
- a3 Distance from wall = max. 200 mm
- a4 Distance from wall = max. tile length
- a5 Distance from DP12 A-Bar suspension point to hanger = max. 100 mm
- M Module size = tile length / tile width 600 x 600, 625 x 625, 900 x 300, 1200 x 300, 1500 x 300 mm

Typical grid layout

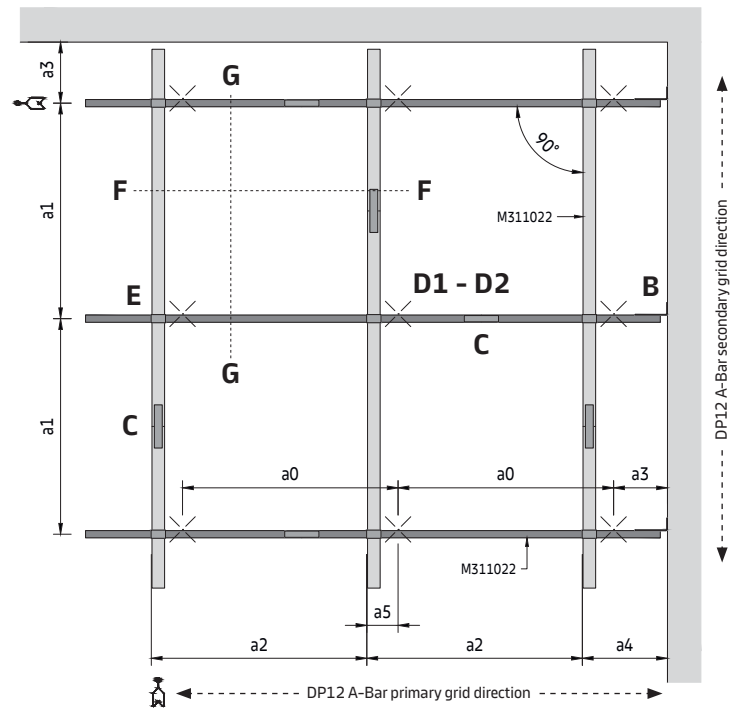

Detail E

Cross connector installation

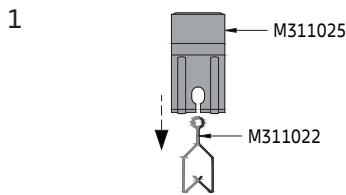

The cross connector is inserted from the end of the DP12 A-Bar secondary grid. Then it can be slid to the correct position.

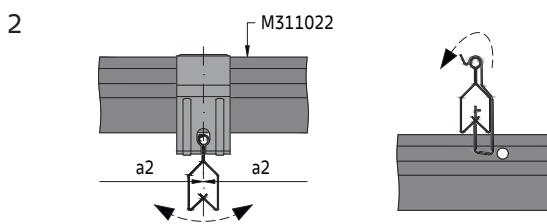

The cross connector for DP12 A-Bar is made of spring steel and is therefore elastic. It is hooked on the DP12 A-Bar primary grid is now locked in position. Due to the round head of the DP12 A-Bar, it can swing. This is important because it allows any tolerances to be compensated. Otherwise the tiles/panels will no longer be inserted after a certain point.

Detail C

Splice connection

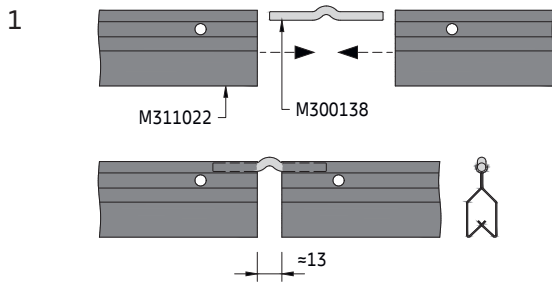

Insert the connection pin at the ends of the DP12 A-Bars and connect them. There is a gap between the DP12 A-Bars. The DP12 A-Bars must be aligned so that the joint is not in the same place as the pips on the tiles.

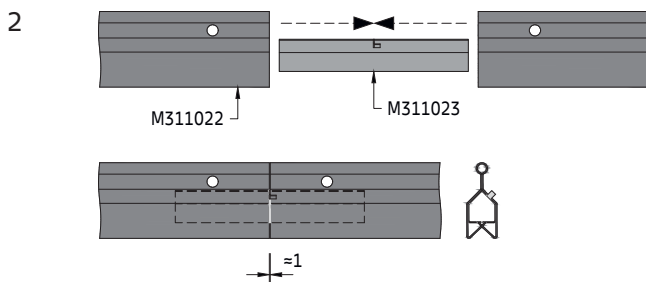

Optionally, the splice connector for DP12 A-Bar can be used. This is inserted at the ends of the DP12 A-Bars and an almost seamless connection is created.

Detail I

Tile insertion

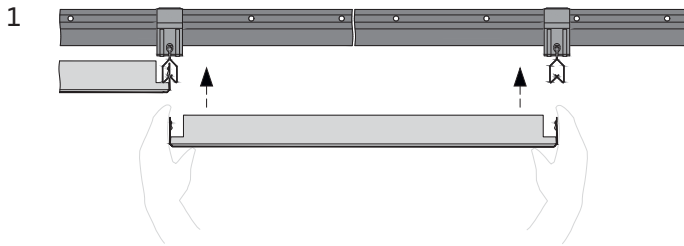

Take the tile and carefully insert it into the DP12 A-Bars from below. Care is required when installing tiles. Always press along the edges with the pips and never on the transverse sides, otherwise the tile may be damaged. The tiles can only be laid in the same direction.

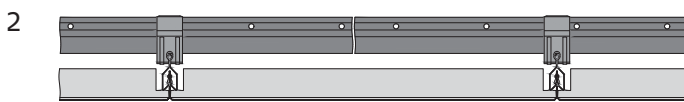

The tiles are correctly inserted when all four corners are flush with the neighbouring tiles. The tiles are designed to match the DP12 A-Bar. If third party profiles are used there is a high probability the tiles will not be correctly inserted.

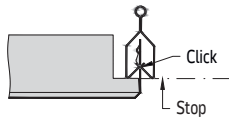

Tile extraction

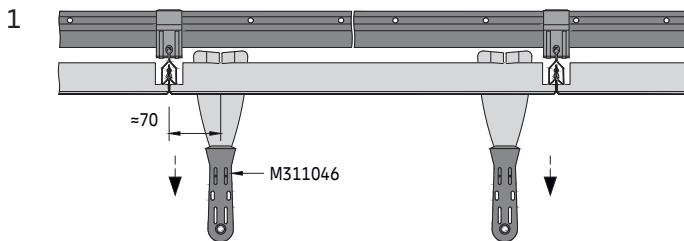

Insert the extraction tool on one side first and pull down with a gentle tug, followed by the opposite side.

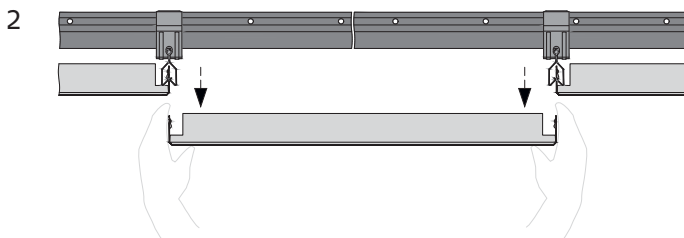

Remove it downwards and store the tile in a safe place so that it cannot be damaged.

Detail J

Included swing-down function

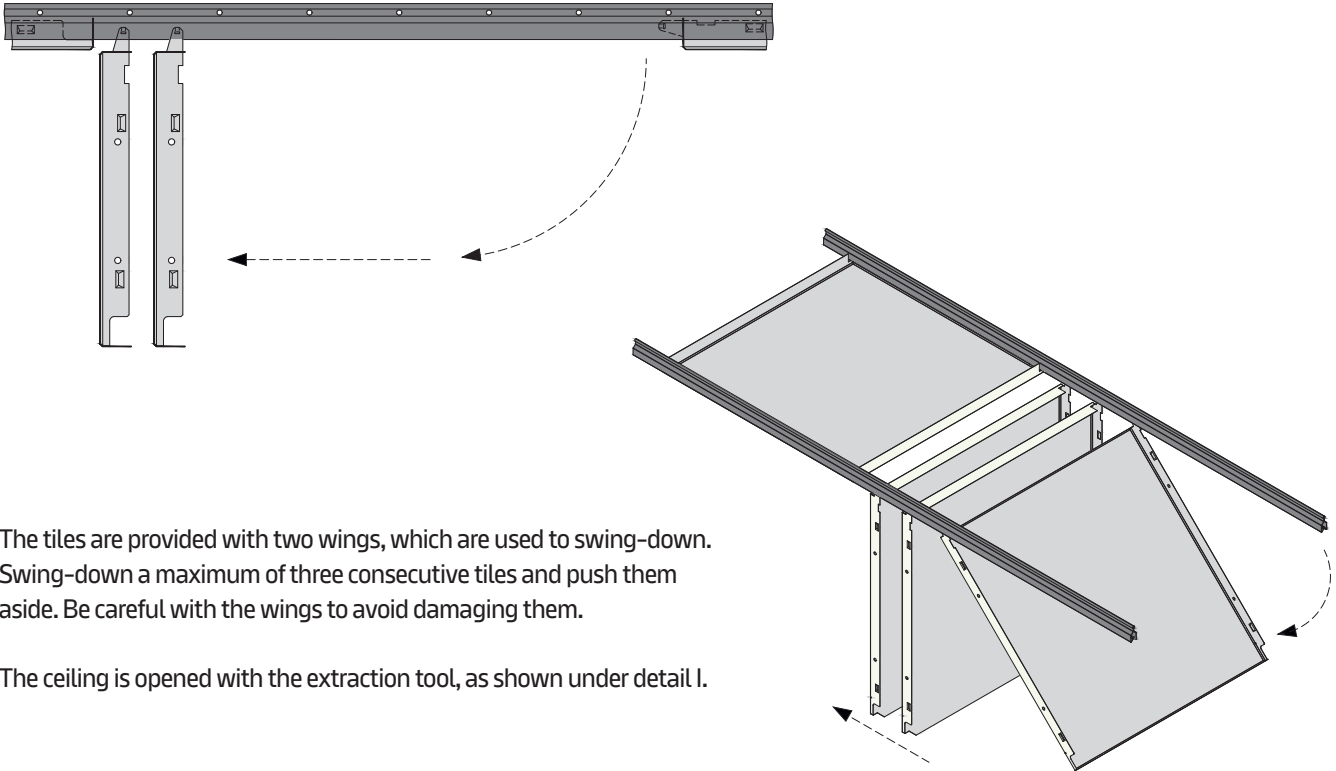

The tiles are provided with two wings, which are used to swing-down. Swing-down a maximum of three consecutive tiles and push them aside. Be careful with the wings to avoid damaging them.

The ceiling is opened with the extraction tool, as shown under detail I.

Material required per m² (no waste included)
System without additional load [pcs/m²]

Components		a2 [mm]	600	625	900	1200	1500
M300138	Connection pin for DP12 A-Bar		0.55	0.54	0.44	0.40	0.37
M311022	DP12 A-Bar		0.55	0.54	0.44	0.40	0.37
M311024	Wall anchor for DP12 A-Bar		0.06	0.06	0.07	0.08	0.09
M311025	Cross connector for DP12 A-Bar		8.88	0.87	0.72	0.62	0.54
Various	Suspension points (D1 - D2)		1.83	1.72	1.96	1.32	0.98

The shown quantities are theoretical and based on an ideal layout, without considering the actual room layout. The ideal layout is based on a calculation of 10 x 10 m (100 m²). This calculation does not allow any damage, spare nor wastage. The final quantities and type of suspension have to be checked before ordering. Soffit and wall fixings by others. Not including perimeter trims and extraction tools.

METAL S-Clip F

C-Channel primary grid + DP12 A-Bar secondary grid
Concealed grid solution for indoor applications

General information

- Concealed clip-in grid system for small and medium rooms
- For perpendicular installation on C-Channel primary grid
- DP12 A-Bar made of galvanised steel
- Typical ceiling weight 5.0 - 5.5 kg/m² (indicative value for unperforated panels / tiles, without additional load)
- Tiles are easily installed and fully demountable
- Included swing-down function

Isometric view

Perimeter solutions on separate datasheet.

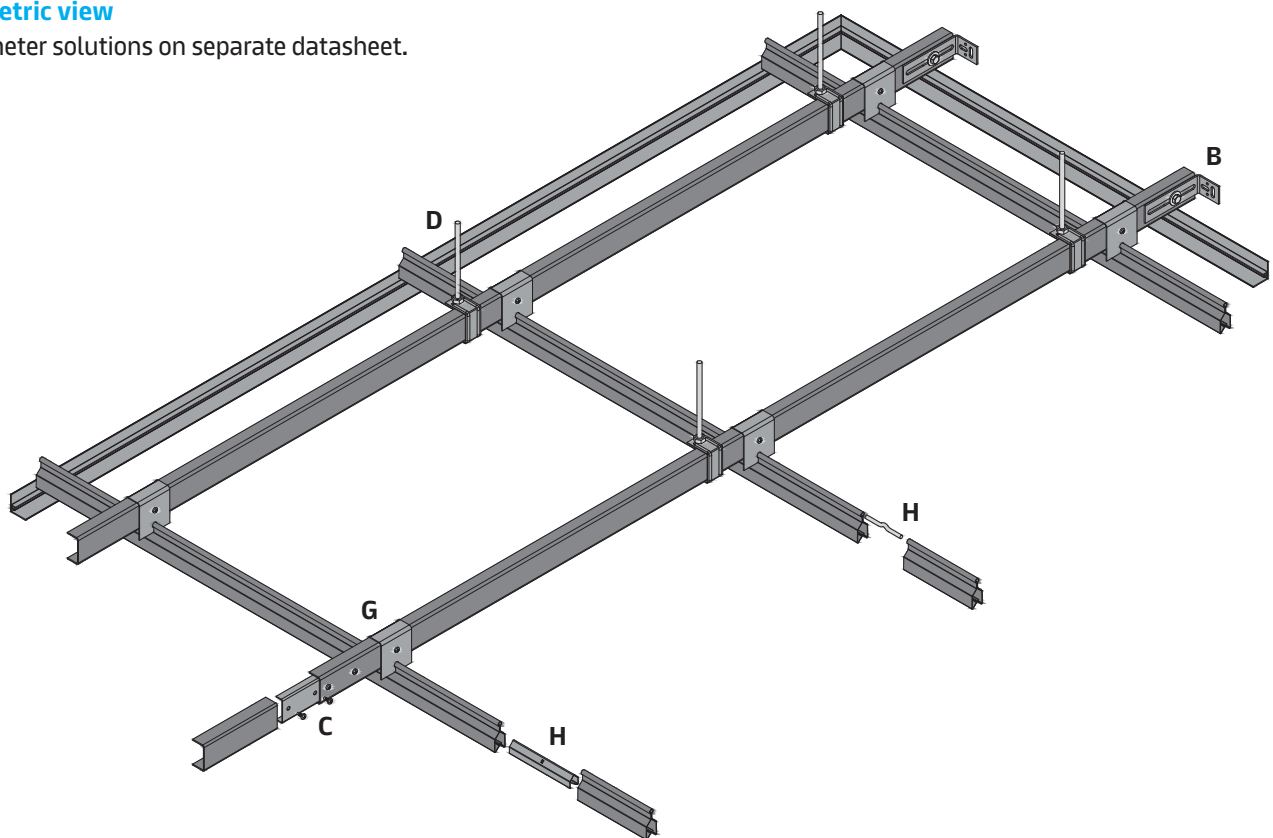

Standard layout options

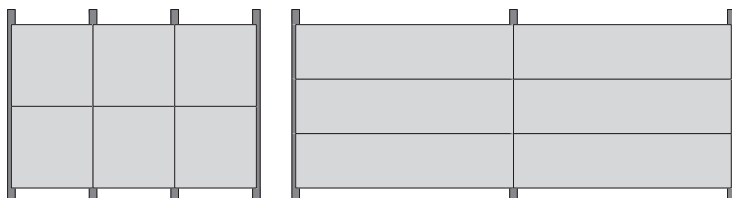

Section E

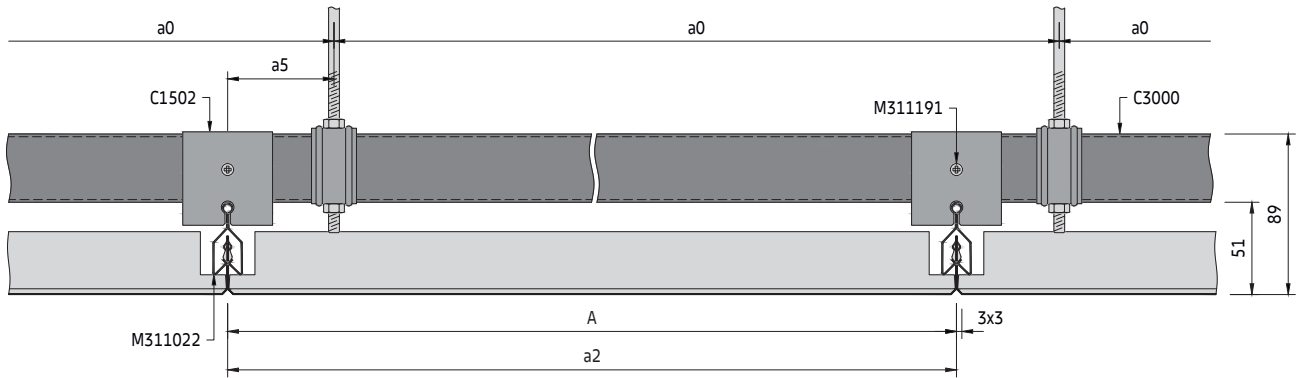

Section F

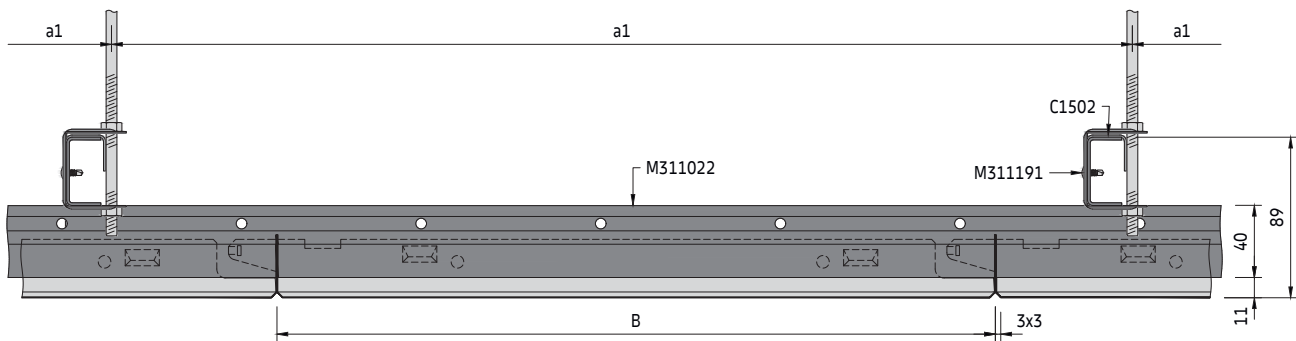

Secondary grid components

Standard components

- M311022 DP12 A-Bar
- M300138 Connection pin for DP12 A-Bar
- C1502 Hanger for DP12 A-Bar
- M311191 Self-drilling screw 3.5 x 9.5 mm

Optional components

- M311023 Splice connector for DP12 A-Bar
- M311046 Extraction tool

See C-Channel primary grid for primary grid components

DP12 A-Bar secondary grid

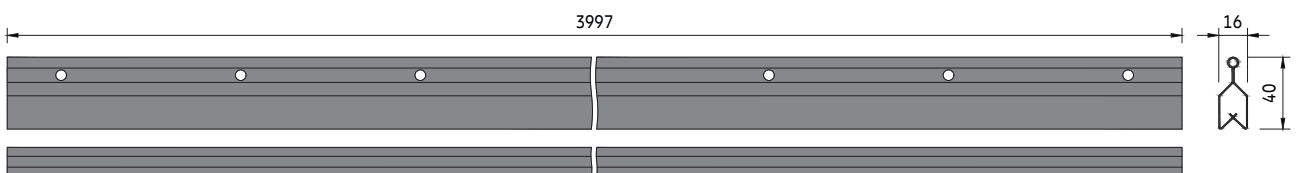

Spacing

a2 [mm]	System without additional load		System with additional load +4 kg/m ²	
	a0 [mm]	a1 [mm]	a0 [mm]	a1 [mm]
600	1200	1900	1200	1850
625	1250	1900	1250	1850
900	900	1900	900	1600
1200	1200	1750	1200	1450
1500	1500	1600	1500	1150

To determine suspension layout

The module length (M) of the requested ceiling is equal to the distance between the DP12 A-Bar centres (a2).

On the appropriate spacing table, read down the column headed (a2) to the required module length then read across to determine the suspension point spacing (a0) and C-Channel spacing (a1).

The shown values are maximum allowed distances and can be reduced but not exceeded.

Parameters

- a0 Distance between C-Channel suspension points = max. 1900 mm
- a1 Max. distance between C-Channels
- a2 Distance between DP12 A-Bars = tile / panel length
- a3 Distance from wall = max. 200 mm
- a4 Distance from wall = max. tile length
- a5 Distance from C-Channel suspension point to hanger = max. 100 mm
- M Module size = tile length / tile width 600 x 600, 625 x 625, 900 x 300, 1200 x 300, 1500 x 300 mm

Typical grid layout

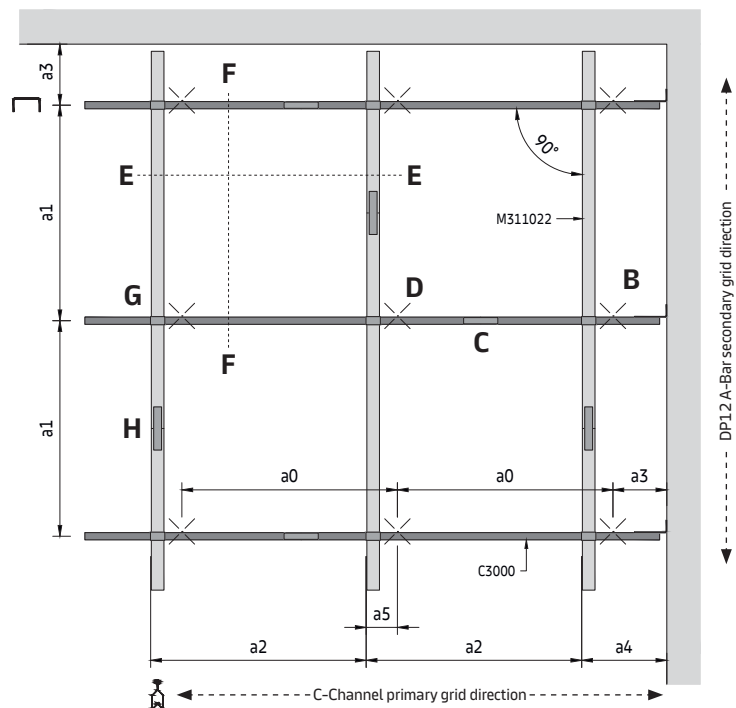

Detail G

Hanger installation

- 1

Insert the hanger for DP12 A-Bar from the end of the DP12 A-Bar.

- 2

Place the DP12 A-Bar including the hanger on the C-Channel. Bend the top flap of the hanger down 90°.

- 3

Take a self-drilling screw and fix the position of the hanger on the C-Channel.

- 4

The DP12 A-Bar is now locked in position. Due to the round head of the DP12 A-Bar, it can swing. This is important, because it allows any tolerances to be compensated. Otherwise the tiles will no longer be inserted after a certain point.

Detail H

Splice connection

- 1

Insert the connection pin at the ends of the DP12 A-Bars and connect them. There is a gap between the DP12 A-Bars. The DP12 A-Bars must be aligned so that the joint is not in the same place as the pips on the tiles.

- 2

Optionally, the splice connector for DP12 A-Bar can be used. This is inserted at the ends of the DP12 A-Bars and an almost seamless connection is created.

Detail I

Tile insertion

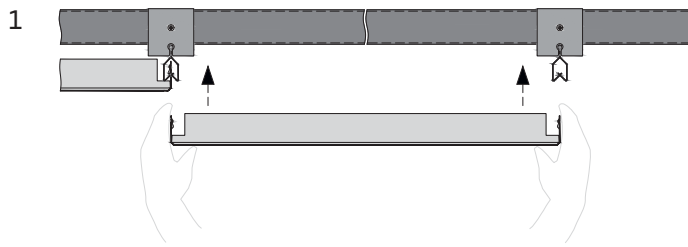

Take the tile and carefully insert it into the DP12 A-Bars from below. Care is required when installing tiles. Always press along the edges with the pips and never on the transverse sides, otherwise the tile may be damaged. The tiles can only be laid in the same direction.



The tiles are correctly inserted when all four corners are flush with the neighbouring tiles. The tiles are designed to match the DP12 A-Bar. If third party profiles are used there is a high probability the tiles will not be correctly inserted.

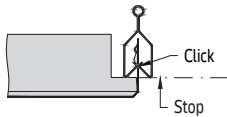

Tile extraction

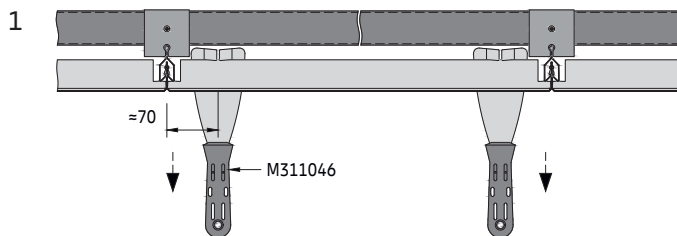

Insert the extraction tool on one side first and pull down with a gentle tug, followed by the opposite side.

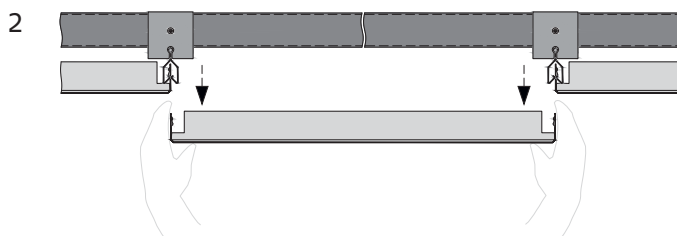

Remove it downwards and store the tile in a safe place so that it cannot be damaged.

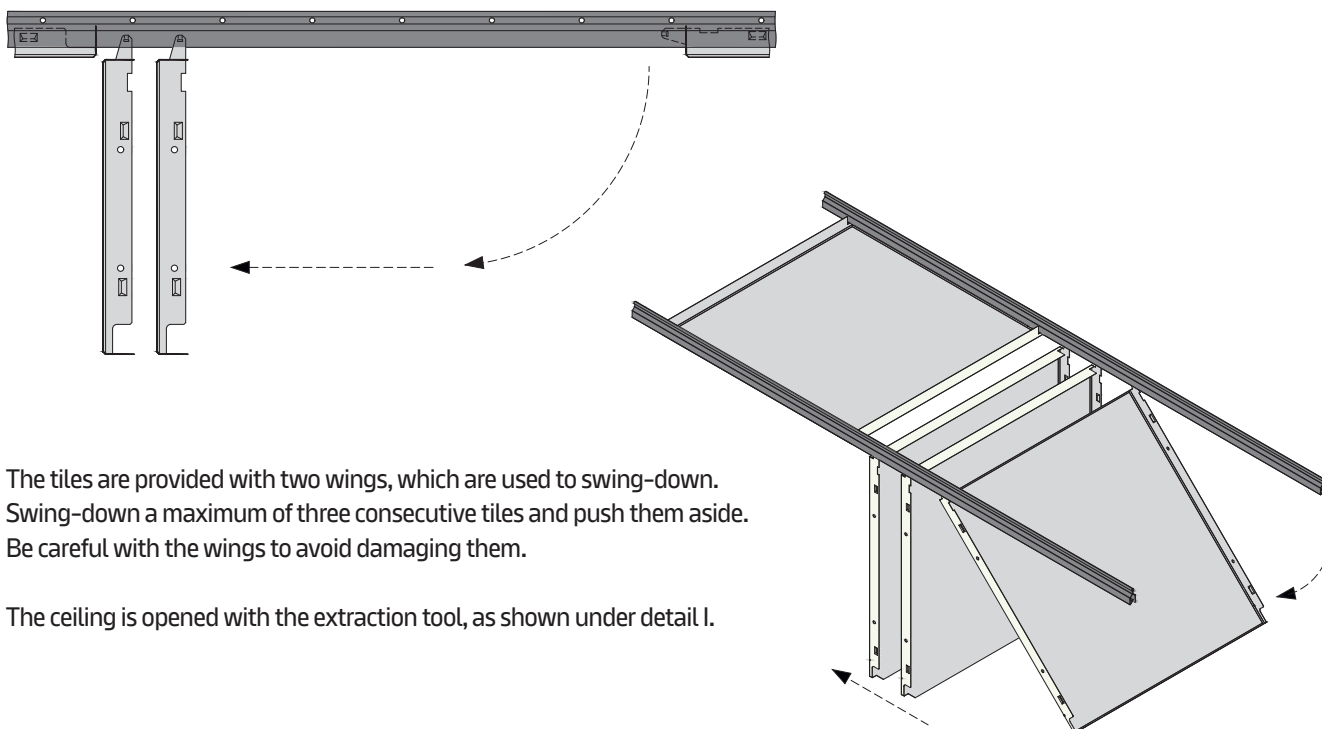
Detail J**Included swing-down function**

The tiles are provided with two wings, which are used to swing-down. Swing-down a maximum of three consecutive tiles and push them aside. Be careful with the wings to avoid damaging them.

The ceiling is opened with the extraction tool, as shown under detail I.

Material required per m² (no waste included)**System without additional load [pcs/m²]**

Components		a2 [mm]	600	625	900	1200	1500
C1502	Hanger for DP12 A-Bar		0.88	0.85	0.59	0.48	0.42
C3000	C-Channel		0.13	0.13	0.13	0.14	0.16
C7140	Splice connector for C-Channel		0.14	0.14	0.14	0.15	0.16
CA97	Clamping bracket for C-Channel		0.44	0.43	0.59	0.48	0.42
M300138	Connection pin for DP12 A-Bar		1.42	0.40	1.28	0.21	0.17
M300140	Wall anchor		0.06	0.06	0.06	0.06	0.07
M311022	DP12 A-Bar		0.42	0.40	0.28	0.21	0.17
M311099	Threaded rod M6 x 1000 mm		0.44	0.43	0.59	0.48	0.42
M311103	Hexagonal nut M6		0.94	0.92	1.24	1.02	0.91
M311105	Washer		0.06	0.06	0.06	0.06	0.07
M311191	Self-drilling screw 3.5 x 9.5 mm		2.28	2.21	1.71	1.50	0.40
M311303	Hexagonal bolt M6 x 16 mm		0.06	0.06	0.06	0.06	0.07

The shown quantities are theoretical and based on an ideal layout, without considering the actual room layout. The ideal layout is based on a calculation of 10 x 10 m (100 m²). This calculation does not allow any damage, spare nor wastage. The final quantities and type of suspension have to be checked before ordering. Soffit and wall fixings by others. Not including perimeter trims and extraction tools.

METAL S-Clip F

Direct suspended DP12 A-Bar
Concealed grid solution for indoor applications

General information

- Concealed clip-in grid system for small areas with low cavity
- DP12 A-Bar made of galvanised steel
- Typical ceiling weight 4.5 - 5.0 kg/m² (indicative value for unperforated panels / tiles, without additional load)
- Tiles are easily installed and fully demountable
- Included swing-down function

Isometric view

Perimeter solutions on separate datasheet.

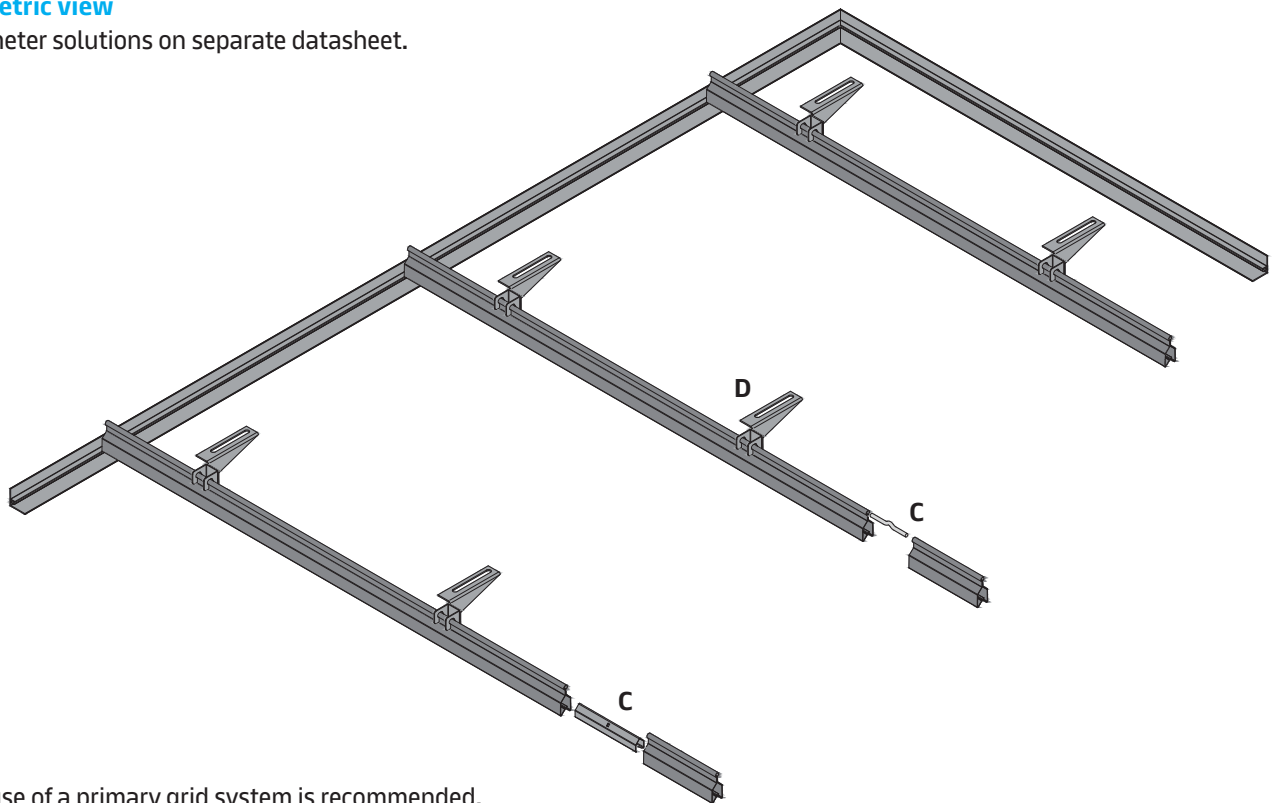

The use of a primary grid system is recommended, as this simplifies levelling and the alignment of the ceiling.

Standard layout options

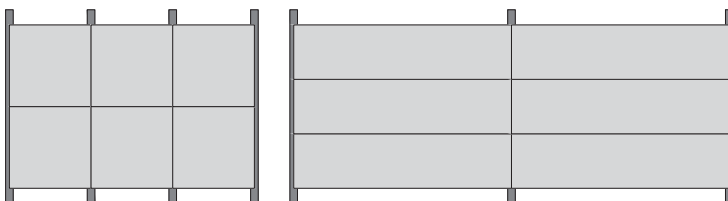

Section A

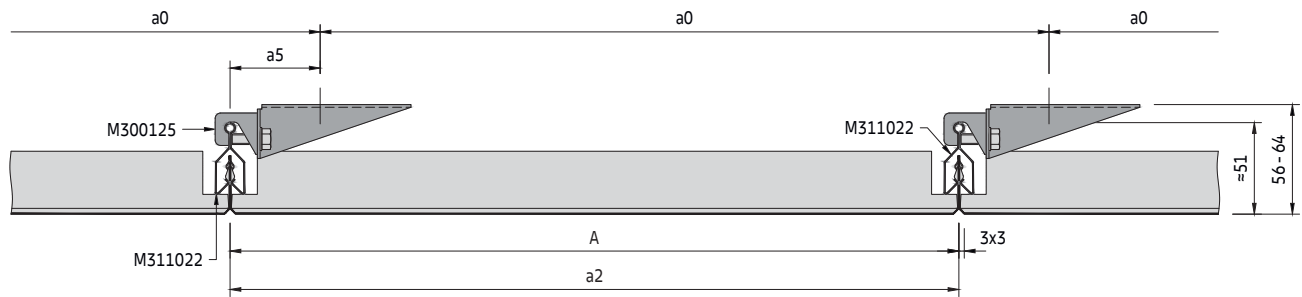

Section B

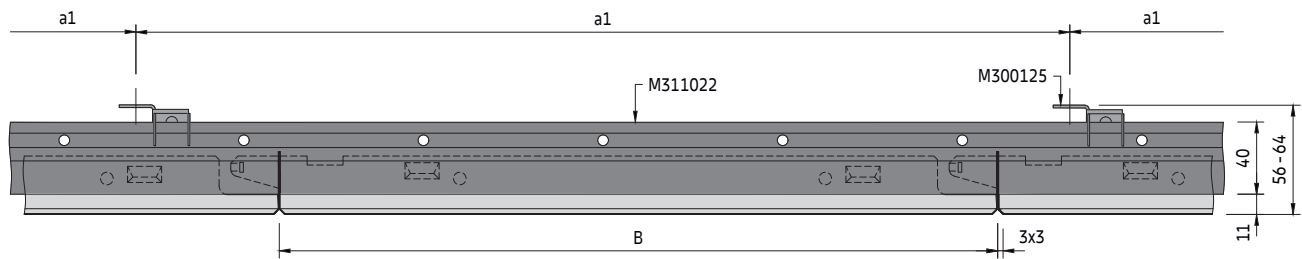

Secondary grid components

Standard components

- M311022 DP12 A-Bar
- M300138 Connection pin for DP12 A-Bar
- M300125 Direct hanger for DP12 A-Bar

Optional components

- M311023 Splice connector for DP12 A-Bar
- M311046 Extraction tool

DP12 A-Bar

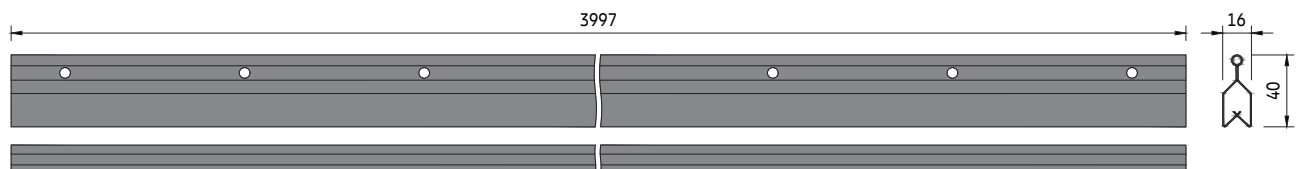

Spacing

a2 [mm]	System without additional load		System with additional load +4 kg/m ²	
	a0 [mm]	a1 [mm]	a0 [mm]	a1 [mm]
600	600	1500	600	1500
625	625	1500	625	1500
900	900	1500	900	1200
1200	1200	1200	1200	1200
1500	1500	1200	1500	1000

To determine suspension layout

The module length (M) of the requested ceiling is equal to the distance between the DP12 A-Bar centres (a2).

On the appropriate spacing table, read down the column headed (a2) to the required module length then read across to determine the suspension point spacing (a0) and direct hanger spacing (a1).

The shown values are maximum allowed distances and can be reduced but not exceeded.

Parameters

- a0 Distance between DP12 A-Bar suspension points
- a1 Max. distance between direct hangers
- a2 Distance between DP12 A-Bars = tile / panel length
- a3 Distance from wall = max. 200 mm
- a4 Distance from wall = max. tile length
- a5 Distance between DP12 A-Bar and top fixing = 38 - 50 mm
- M Module size = tile length / tile width 600 x 600, 625 x 625, 900 x 300, 1200 x 300, 1500 x 300 mm

Typical grid layout

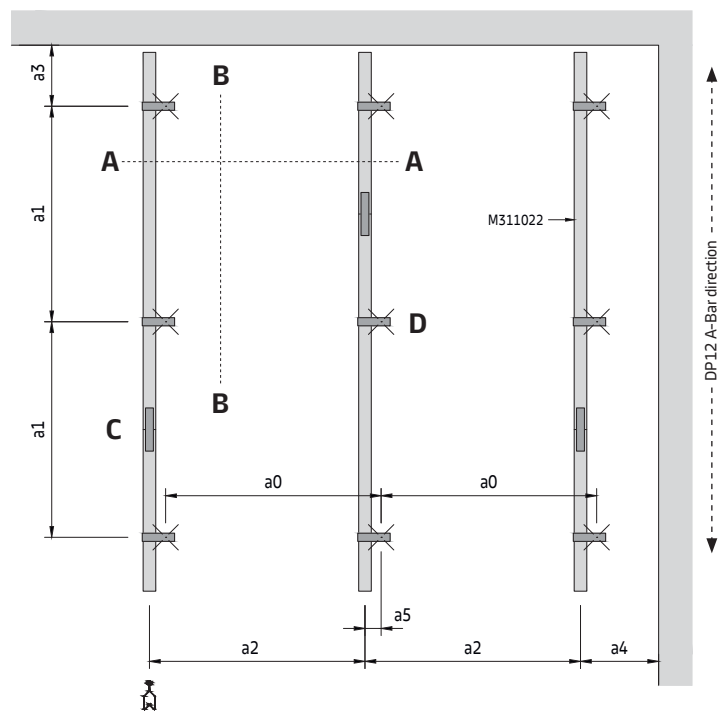

Detail C

Splice connection

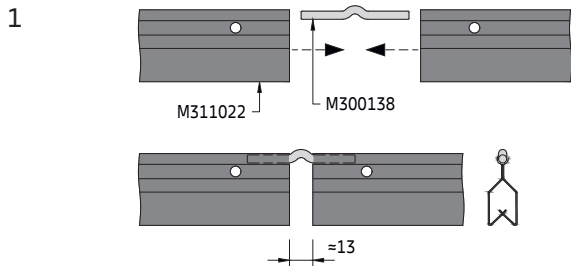

Insert the connection pin at the ends of the DP12 A-Bars and connect them. There is a gap between the DP12 A-Bars. The DP12 A-Bars must be aligned so that the joint is not in the same place as the pips on the tiles.

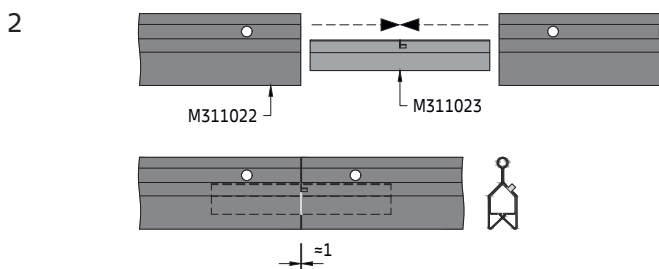

Optionally, the splice connector for DP12 A-Bar can be used. This is inserted at the ends of the DP12 A-Bars and an almost seamless connection is created.

Detail D

Direct hanger installation

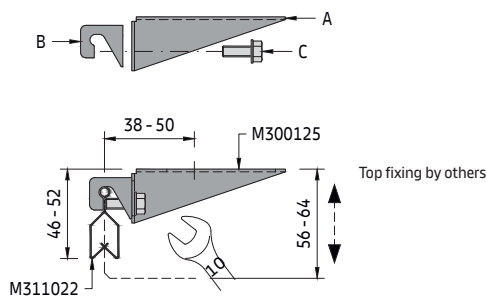

The direct hanger consists of three pre-assembled components (A, B, C).

Make sure that the position of the direct hanger does not interfere with the edge of the tiles.

Part A is attached to the soffit first. The distance from the DP12 A-Bar to the attachment point must not exceed 50 mm.

Part B is not tightened, so the DP12 A-Bar can be inserted from below. Tightening the bolt (part C) creates a stable connection. Before that, the height should be set up.

Optional installation

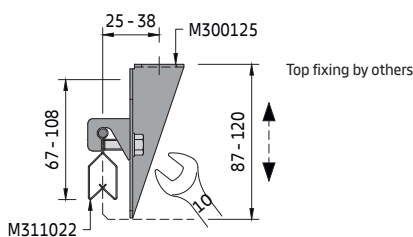

The distance between the DP12 A-Bars should be measured exactly, otherwise the tiles are difficult to install and elements could fall out.

The direct hanger can optionally also be installed vertically. To do this, the components must first be disassembled. The shorter side of part A is then attached to the soffit.

Detail E

Tile insertion

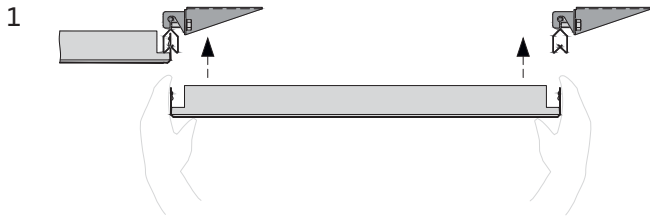

Take the tile and carefully insert it into the DP12 A-Bars from below. Care is required when installing tiles. Always press along the edges with the pips and never on the transverse sides, otherwise the tile may be damaged. The tiles can only be laid in the same direction.

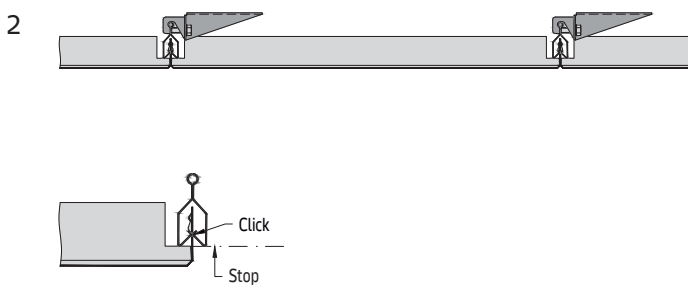

The tiles are correctly inserted when all four corners are flush with the neighbouring tiles. The tiles are designed to match the DP12 A-Bar. If third party profiles are used there is a high probability the tiles will not be correctly inserted.

Tile extraction

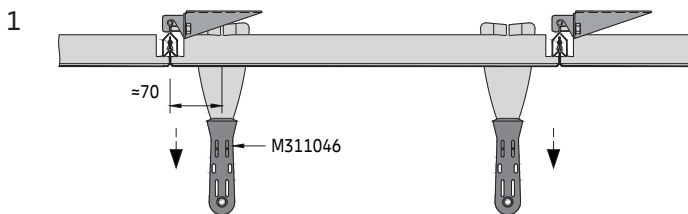

Insert the extraction tool on one side first and pull down with a gentle tug, followed by the opposite side.

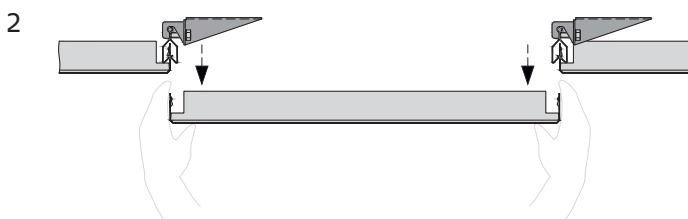

Remove it downwards and store the tile in a safe place so that it cannot be damaged.

Detail F

Included swing-down function

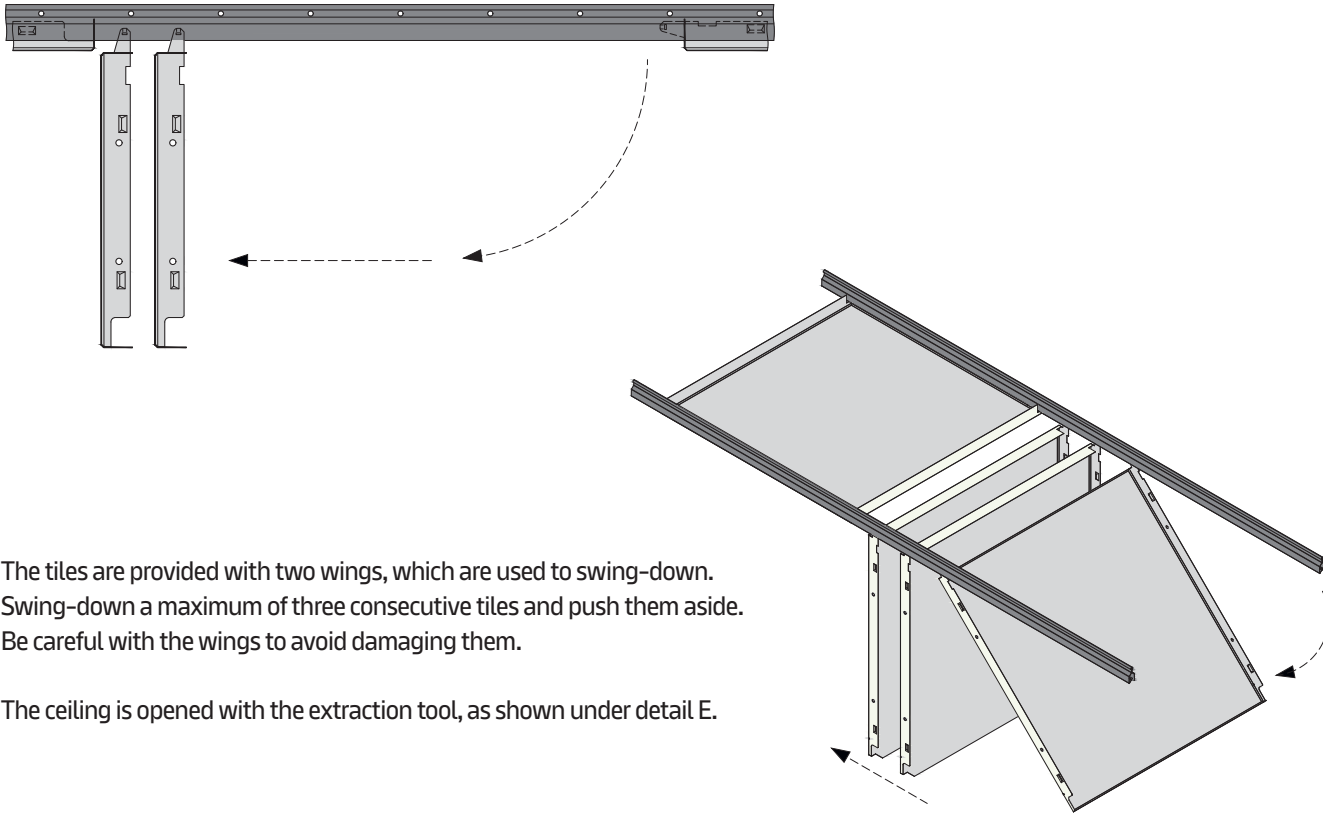

The tiles are provided with two wings, which are used to swing-down. Swing-down a maximum of three consecutive tiles and push them aside. Be careful with the wings to avoid damaging them.

The ceiling is opened with the extraction tool, as shown under detail E.

Material required per m² (no waste included)

System without additional load [pcs/m²]

Components		a2 [mm]	600	625	900	1200	1500
M300125	Direct hanger for DP12 A-Bar		1.33	0.54	0.93	0.69	0.56
M300138	Connection pin for DP12 A-Bar		0.42	0.54	0.28	0.21	0.17
M311022	DP12 A-Bar		0.42	1.72	0.28	0.21	0.17

The shown quantities are theoretical and based on an ideal layout, without considering the actual room layout. The ideal layout is based on a calculation of 10 x 10 m (100 m²). This calculation does not allow any damage, spare nor wastage. The final quantities and type of suspension have to be checked before ordering. Soffit and wall fixings by others. Not including perimeter trims and extraction tools.

METAL Baffle Sky Element

Direct suspended by threaded rods
For indoor applications

General information

- Direct suspended system for medium and large rooms
- Typical ceiling weight 12.0 - 24.0 kg/m² (indicative value for unperforated baffles, without additional load)
- Baffles crosswise installed

Isometric view

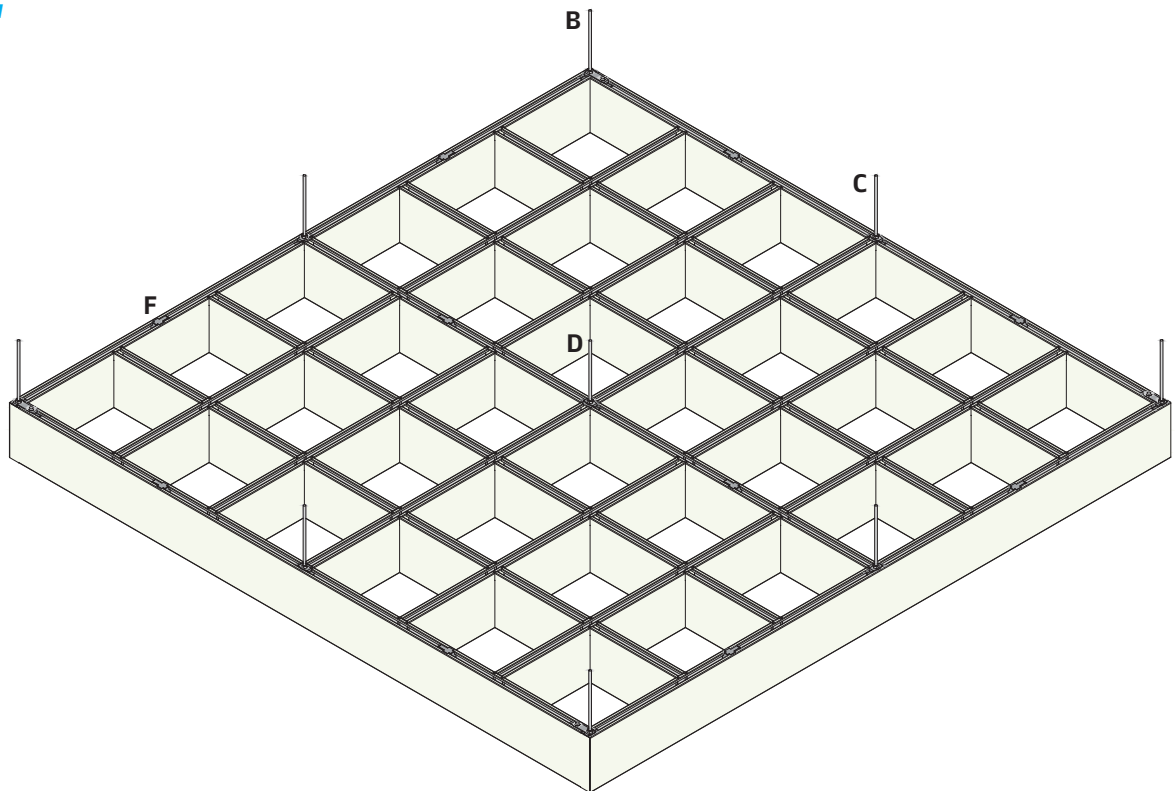

Vario Design & bespoke layout options

Vario Design

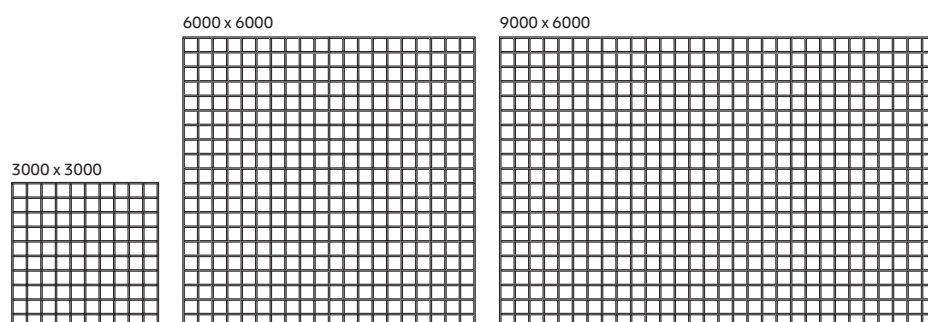

Bespoke (on request)

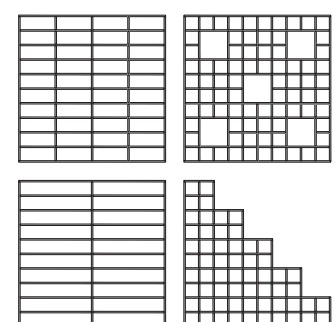

METAL Baffle Sky Element

E02.101

Section A

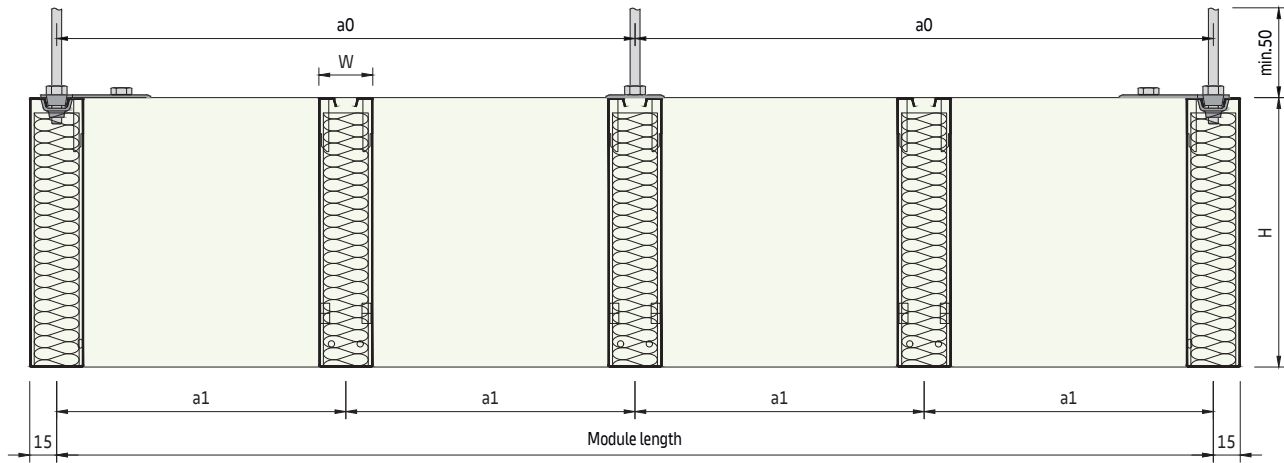

Typical layout

Example with 3000 x 3000 mm module

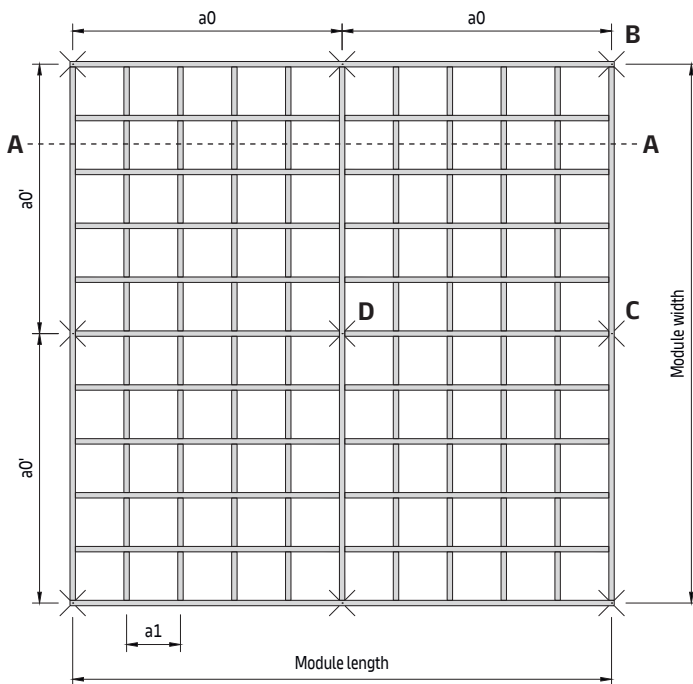

Parameters

- a0 Distance between suspension points = 1500 mm
- a0' Distance between suspension points = 1500 mm
- a1 Distance between baffles = 300 mm
- L Baffle length = various lengths, up to 3030 mm
- H Baffle height = 150 / 200 / 250 / 300 mm
- W Baffle width = 30 mm

Grid components

Standard components

- M311039 Grip 30 mm for METAL Baffle Sky Element
- M311040 Coupling holder for METAL Baffle Sky Element
- M311041 Corner coupling holder for METAL Baffle Sky Element
- M311042 Coupling clamp for METAL Baffle Sky Element
- M311043 Corner clamp for METAL Baffle Sky Element
- M311044 Distance holder for baffle
- M311099 Threaded rod M6 x 1000 mm
- M311103 Hexagonal nut M6
- M311303 Hexagonal bolt M6 x 16 mm
- M311307 Pop-rievet TAPD 44 BS

METAL Baffle Sky Element

E02.101

Detail B

Corner connection with suspension

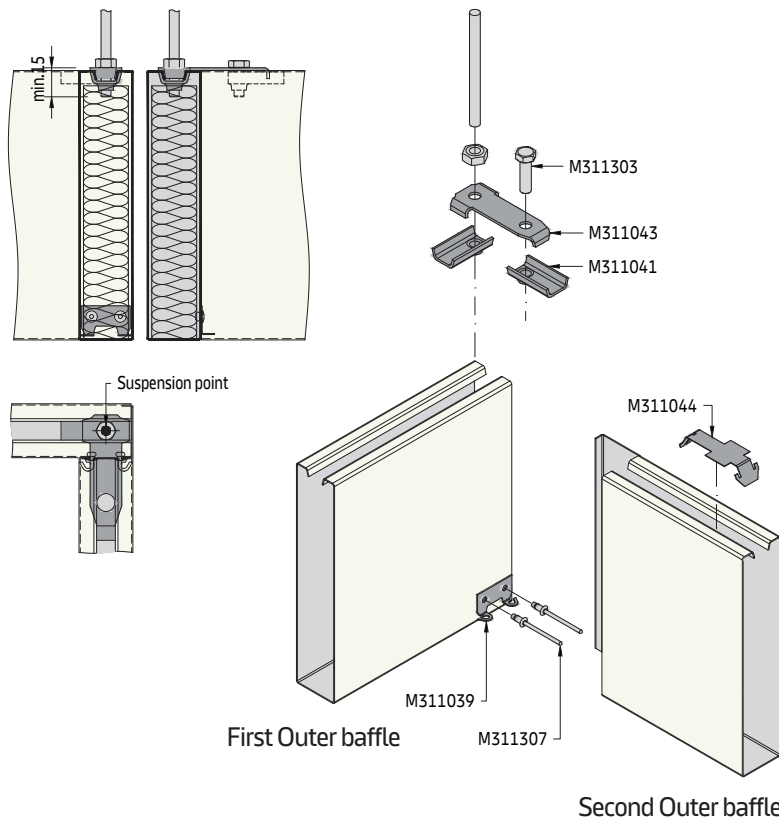

- 1 Install the threaded rod in the required length.
- 2 Insert the hexagonal nut M311303, followed by the corner coupling clamp M311043. The nut should be screwed in at least 10 mm higher than the end position.
- 3 Adjust the correct height by inserting the corner coupling holder M311041. Make sure the orientation is correct.
- 4 Insert the first outer baffle.
- 5 Complete the connection by tightening the nut.
- 6 Fix the grip M311039 on the baffle with two pop-rivets M311307.
- 7 Use the hexagonal bolt M6 M311303 to fix the second corner coupling holder M311041 to the corner coupling clamp M311043. Leave some space between.
- 8 Insert the second outer baffle and complete the connection by tightening the nut.
- 9 Insert the distance holder as described at detail F on both outer baffles.

Detail C

T-connection with suspension

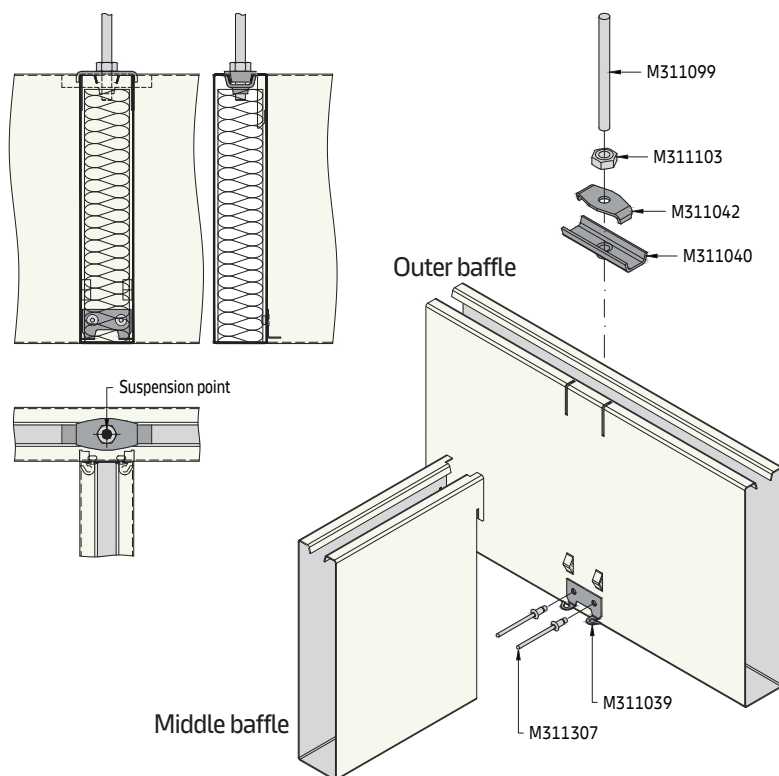

- 1 Install the threaded rod in the required length.
- 2 Insert the hexagonal nut M311303, followed by the coupling clamp M311042. The nut should be screwed in at least 10 mm higher than the end position.
- 3 Adjust the correct height by inserting the coupling holder M311040. Make sure the orientation is correct.
- 4 Insert the outer baffle.
- 5 Complete the connection by tightening the nut.
- 6 Fix the grip M311039 on the baffle with two pop-rivets M311307.
- 7 Hang the middle baffle from above using the hooks and press the outer baffle with the hooks against the end. This ensures that no gap is left between the baffles.

METAL Baffle Sky Element E02.101

Detail D

Three baffles cross connection with suspension

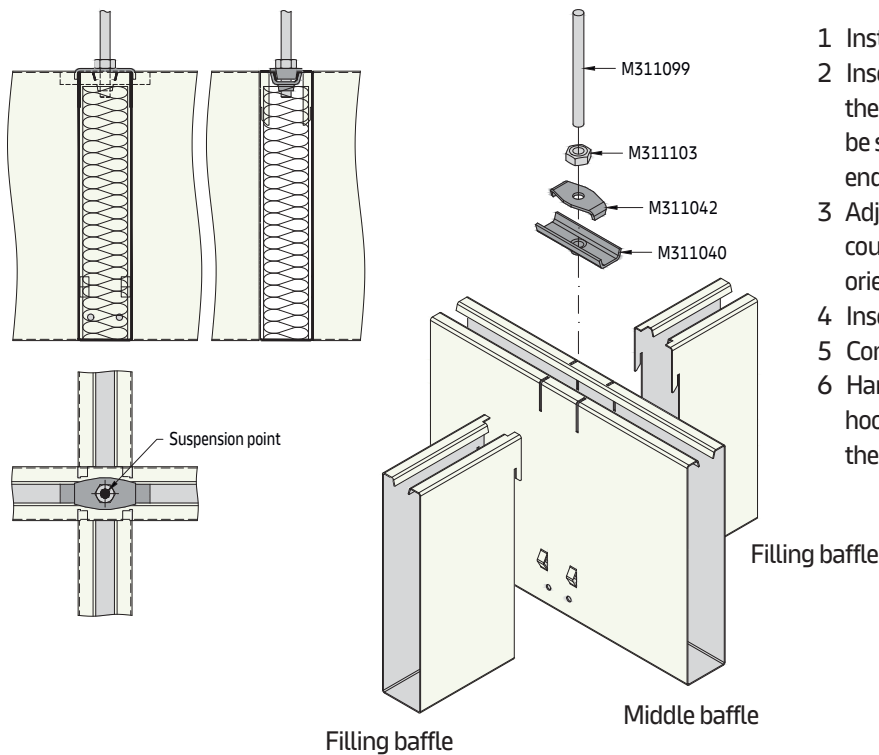

- 1 Install the threaded rod in the required length.
- 2 Insert the hexagonal nut M311303, followed by the coupling clamp M311042. The nut should be screwed in at least 10 mm higher than the end position.
- 3 Adjust the correct height by inserting the coupling holder M311040. Make sure the orientation is correct.
- 4 Insert the middle baffle.
- 5 Complete the connection by tightening the nut.
- 6 Hang the filling baffles from above using the hooks. The embossing at the bottom ensures the baffle is vertically aligned.

Detail E

Four baffles cross connection with suspension

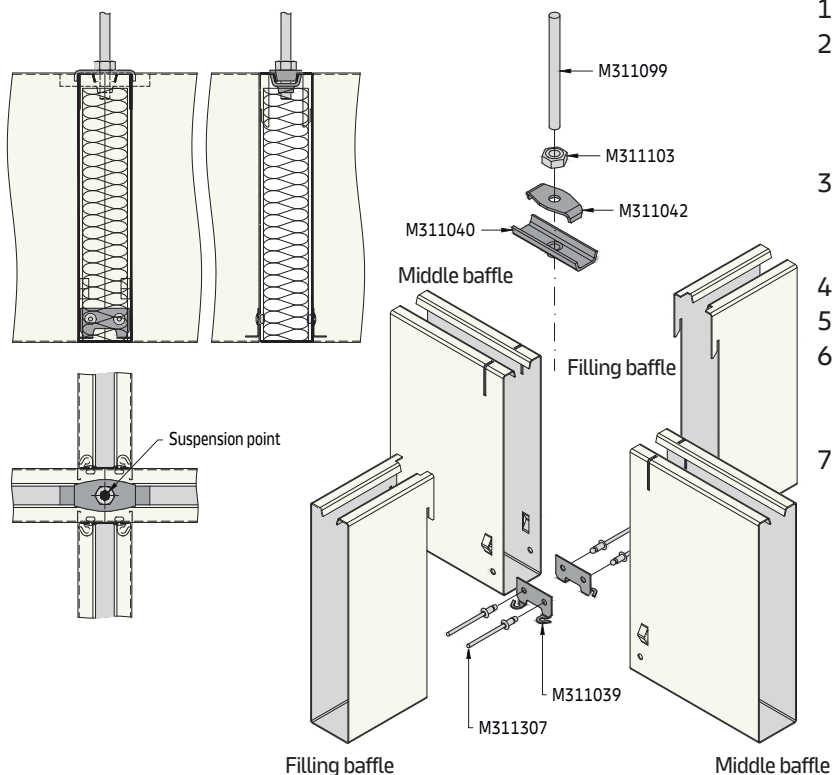

- 1 Install the threaded rod in the required length.
- 2 Insert the hexagonal nut M311303, followed by the coupling clamp M311042. The nut should be screwed in at least 10 mm higher than the end position.
- 3 Adjust the correct height by inserting the coupling holder M311040. Make sure the orientation is correct.
- 4 Insert the middle baffles.
- 5 Complete the connection by tightening the nut.
- 6 Fix the grips M311039 on the baffle with two pop-rivets M311307 each. This builds a straight connection.
- 7 Hang the filling baffles from above using the hooks. The embossing at the bottom ensures the baffle is vertically aligned.

METAL Baffle Sky Element

E02.101

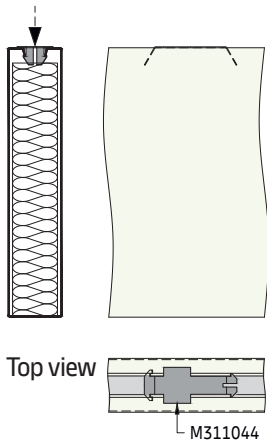
Detail F**Distance holder**

The distance holder is pushed into the baffle from above. At least two pieces are required per baffle. The distance holders are only needed on the outer and middle baffles.

The distance holder keeps the top ends of the baffle at the correct distance and parallel.

Material required per m² (no waste included)

System without additional load, including standard acoustic infill [pcs/module]

Components		a2 [mm]	3000 x 3000	6000 x 6000	9000 x 6000
M311039	Grip 30 mm for METAL Baffle Sky Element		22	82	104
M311040	Coupling holder for METAL Baffle Sky Element		5	21	27
M311041	Corner coupling holder for METAL Baffle Sky Element		4	4	4
M311042	Coupling clamp for METAL Baffle Sky Element		5	21	27
M311043	Corner clamp for METAL Baffle Sky Element		4	4	4
M311044	Distance holder for baffle		10	20	28
M311099	Threaded rod M6 x 1000 mm		9	25	35
M311103	Hexagonal nut M6		9	25	35
M311303	Hexagonal bolt M6 x 16 mm		4	4	4
M311307	Pop-rivet TAPD 44 BS		44	164	208

This calculation does not allow any damage, spare nor wastage. The final quantities and type of suspension have to be checked before ordering. Soffit fixing by others.

Installation sequence

Example with 3000 x 3000 mm module

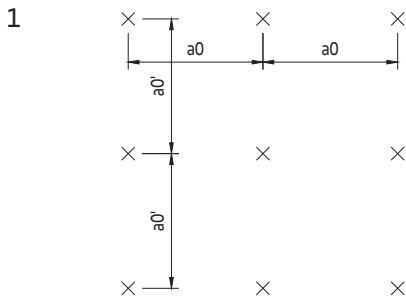

Place the threaded rods in the required length at a distance of a_0 and a_0 !

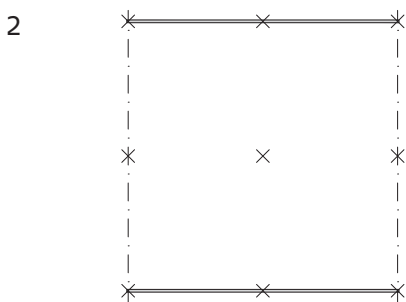

Install the outer two baffles. Make sure these are aligned with each other. See corner connection detail B.

Add two distance holders per baffle. See detail F.

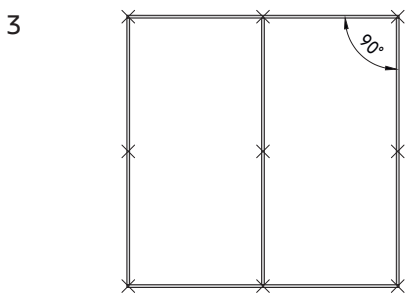

Add the cross baffles on the outside. See corner connection detail B.

Fix the grips on the outer baffles with two pop-rivets, before hanging the middle baffle. See T-connection detail C.

Make sure the baffles are installed at a 90° angle.

Add two distance holders per baffle. See detail F.

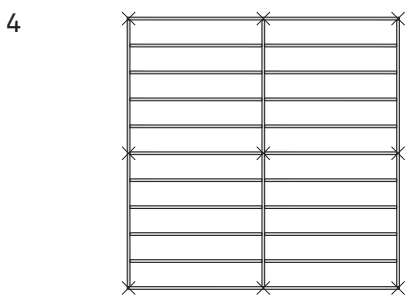

Hang the long filling baffles. See cross-connection detail D.

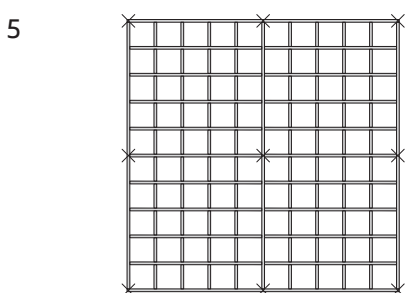

Hang the short filling baffles to complete the installation.