

# ***KNAUF***

## ***AQUAPANEL<sup>®</sup> CEMENT BOARD OUTDOOR***

Cement Board For Outdoor Applications & Ideal  
Substrate Board For Render and Cladding

***Build on us.***

# CONTENTS

<b>Faster construction with Knauf AQUAPANEL® Cement Board Outdoor Systems</b>	<b>4</b>
<b>BBA certified</b>	<b>7</b>
<b>Knauf</b>	<b>8</b>
<b>Support</b>	<b>10</b>
<b>Ecofast Modular-Build Showroom – Case Study</b>	<b>14</b>
<b>A higher return on investment</b>	<b>16</b>
<b>New design possibilities for curved walls</b>	<b>19</b>
<b>Knauf AQUAPANEL® Cement Board Outdoor System</b>	<b>20</b>
<b>Abbeyfield Winnersh Care Home – Case Study</b>	<b>22</b>
<b>Installation procedure</b>	<b>24</b>
<b>Application details</b>	<b>26</b>
<b>Fixing details</b>	<b>29</b>
<b>Drained and vented cavity</b>	<b>35</b>
<b>Knauf AQUAPANEL® Exterior Ceiling System</b>	<b>36</b>
<b>Knauf AQUAPANEL® Exterior Soffit Lining Detail</b>	<b>38</b>
<b>AQUAPANEL® Cement Board Outdoor</b>	<b>39</b>
<b>AQUAPANEL® outdoor boards and accessories</b>	<b>42</b>
<b>Training courses available</b>	<b>45</b>
<b>Look to the future - Build on us</b>	<b>46</b>

**There's an increasing demand to build faster, more efficiently and cost effectively. There's a global call for more imaginative and sustainable designs. There is a revolution in materials and construction techniques, opening up a new world of possibilities.**

Architects are at the forefront of these changes. Driven by their vision and experience, the built environment is changing for the better, with more ambitious ideas, inspirational designs and beautiful spaces where people want to live and work.

For over 80 years, Knauf has been partnering with architects to shape this new landscape. Continually pioneering new products, services and solutions in facade and drywall construction, we push the boundaries of what is possible, opening the door to bolder design and better buildings. This is our expertise. Combined with the experience and talent of architects, we're changing the way the world builds – more creatively, more efficiently, more sustainability.

***Build on us.***

# Faster Construction with Knauf AQUAPANEL® Cement Board Outdoor Systems

**Faster construction is already the preferred method for numerous offsite and onsite projects due to the benefits it brings in reduced timescales, lightweight and thin exterior walls, consistency and improved health and safety.**

Knauf AQUAPANEL® Cement Board Outdoor is an ideal substrate for directly applied render finishes and can be used for exterior walls in drained and ventilated systems, exterior ceilings and soffits. Additionally, it is an ideal substrate for slip bricks, natural stone and exterior tiles with weight options to 40kg/m<sup>2</sup> without issue (heavier weights possible, contact Knauf Technical Services).

Knauf AQUAPANEL® Cement Board Outdoor panels provide a solid, dry base that can withstand the extreme weathering effects of wind, rain and snow. It can be easily curved, allowing for striking architectural features to be formed. It is also ideal for creating exterior soffits and the illusion of an internal ceiling continuing through the façade to the outside of the building.

## Exterior cladding

Knauf AQUAPANEL® Cement Board Outdoor is ideal for use on multiple structure backgrounds. It is mechanically fixed to a structure creating a rainscreen cladding cavity that is drained and ventilated at the base, and ventilated at the head using either treated timber or aluminum helping hand bracket. Multiple cladding finish options are available following the tape & joint process plus basecoat and mesh application.

## Exterior ceilings and soffits

Creating seamless exterior ceilings and soffits with Knauf AQUAPANEL® Cement Board Outdoor is simple. It is mechanically fixed to Knauf Suspended Coated metal framework and provides a smooth finish for further decoration.

The Knauf AQUAPANEL® Cement Board Outdoor and Suspended Coated metal framework system provides an internal ceiling look to the outside of a building in a fast, high quality and extremely economical manner, and its simplicity allows internal ceiling contractors to carry out similar practice for exterior work.

For support on specification or for further information please contact: [technical-uk@knauf.com](mailto:technical-uk@knauf.com)





## BBA Certified

**BBA Certified The Knauf AQUAPANEL® Cement Board Outdoor System has been rigorously tested and certified by the BBA, for use as a ventilated exterior wall panel system on timber frame and steel frame buildings.**

**As part of the BBA Certification, the Knauf AQUAPANEL® Cement Board Outdoor System has been assessed for:**

- Meeting requirements for building regulations
- Strength and stability: Impact testing
- Non-combustible board: meeting fire classification of A1 in accordance with EN 13501. Suitable product for use in exterior wall systems
- Weather tightness: the system resists the passage of moisture from the ground and from weather
- Stability: Mould and mildew resistant and freeze and thaw tested
- Performance: DOP, DOA and BBA Certificated

**The BBA Certificate also covers:**

- Independently verified technical specification, including review of production and quality standards
- Design considerations: a review of the standard installation details
- Installation guidance: basic installation instructions
- Information in relation to Construction (Design and Management) Regulations 2007
- For more information, refer to BBA Certificate Number 09/4633 or search "AQUAPANEL®" at [bbacerts.co.uk](http://bbacerts.co.uk) or contact Knauf Technical Services.





## KNAUF

**Knauf UK began its journey in 1988 when the Knauf Group recognised the need for high quality plasterboard products for the UK and Ireland markets.**

Building began and a new state of the art plasterboard factory was built in Sittingbourne, Kent. Only two years later, we opened a second plasterboard plant in North East Lincolnshire to meet the ever growing demand for plasterboard and system solution products. Furthermore, our third plant was bought in 2022 which will be commissioned and live at the end of 2023. Making us one of the largest plasterboard and system solution manufactures in the UK.

In 2013 at Sittingbourne we opened a striking modernist-inspired building known as The Cube - an innovative training, visitor and administrative centre. Utilising all Knauf systems and products as part of the construction, including Knauf AQUAPANEL® Cement Board Outdoor as the render carrier board.



### Sustainability:

We are committed to a high standard of sustainability and environmental responsibility. During product manufacturing and the factory operation we are always mindful of this. The same is true for our work with contractors and architects during design and build.



### Certification:

Knauf UK and Ireland is recognised in the UK by numerous certification and accreditation bodies. This is where you'll find all our ISO, BES, Environmental Product Declarations (EPDs) and other related downloads.



### Policies:

These pages highlight our key policies in the areas of quality, safety and the environment. As a family owned business we take the welfare of our employees, customers and the environment very seriously.



### Contact us:

Speak to our Project Specification Managers who can help with design and technical advice.

# Creative Freedom Without Limits

**Architects and specifiers worldwide are discovering the liberating potential of Knauf AQUAPANEL® Cement Board Outdoor Technology.**

Strong, light and easy to shape into inspirational designs, the system is also able to accommodate a huge range of finishes to beautiful effect. And thanks to its easy adaptability and simple integration of building technology, Knauf Cement Board Outdoor always remains flexible against any usage – or weather-related influences.

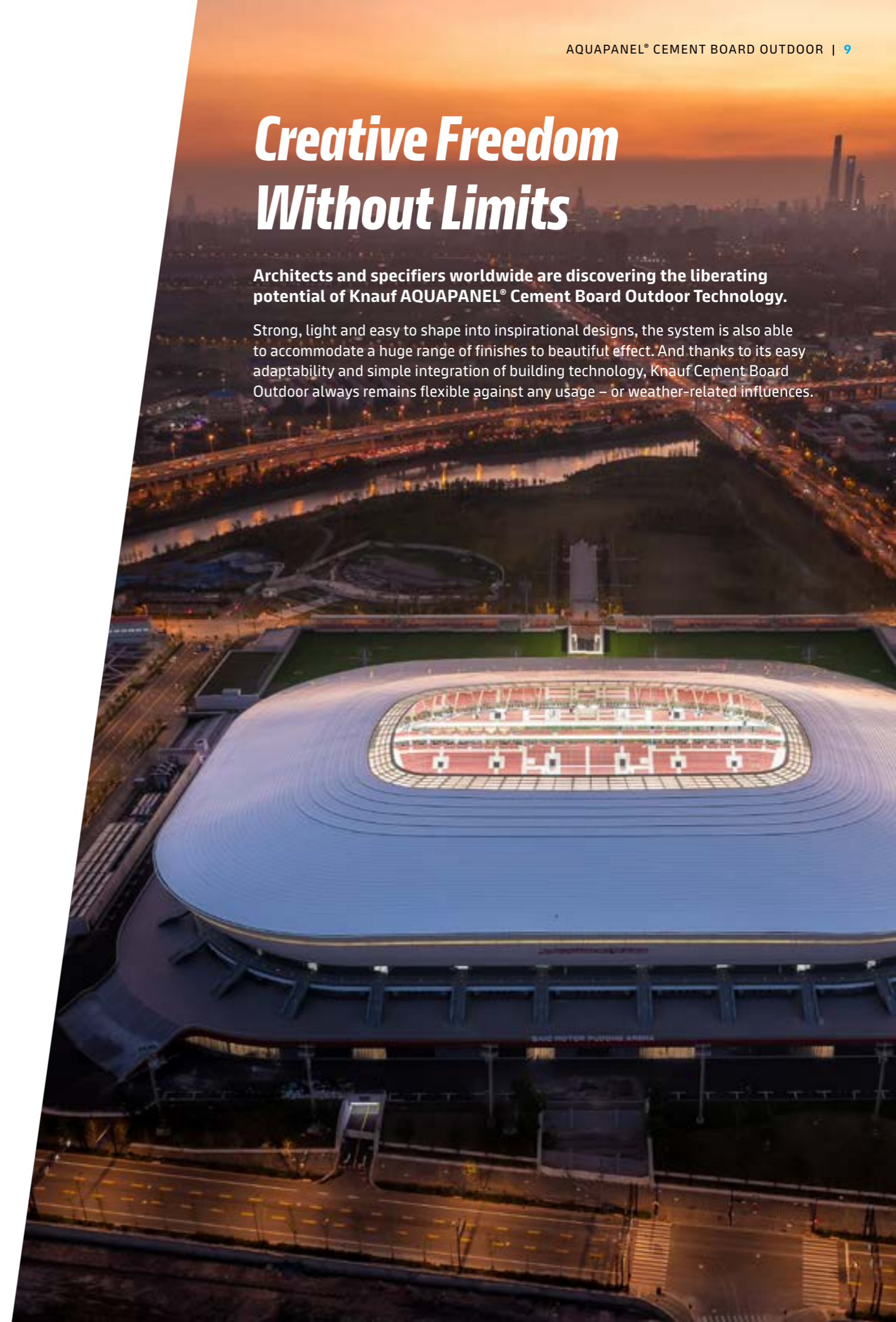

# Support

## Quality

The Knauf Group is one of the largest construction material manufacturer in the world. Still family owned, with our presence in over 90 countries, we pride ourselves on the quality of our products and our commitment to staff and customers – not shareholders. Knauf manufacture in the UK to EN 520, BS 1191 and BS EN ISO 9000 using advanced production facilities.

## Performance

Our systems use Knauf materials throughout – board, metal, insulation, plaster and accessories. All are manufactured to strict British and European Standards and are thoroughly independently tested together as complete, warranted systems. Fire, acoustic, robustness, longevity, and structural performance are all tested for the relevant application.

Full details can be found on our website; [knauf.co.uk](http://knauf.co.uk)

## Systems

We know that finding the best solution for your project is paramount and our systems give you a leading edge, through simplicity of construction, performance and value for money.

### See all Our System Solutions:



## Project and Specification Managers

Our national team of Project & Specification Managers (PSMs) can provide help and support throughout the duration of your project. They are often involved with the entire supply chain from the distributor through to the client, speeding up the flow of information and spotting and eliminating likely issues. Our PSMs are all highly skilled and technically qualified, and specialise in bespoke design and value engineering large projects.

For any queries in the UK and Ireland please email [technical-uk@knauf.com](mailto:technical-uk@knauf.com)



## Performance Warranty

Through proving a single source of supply of various components Knauf can offer complete peace of mind for clients, specifiers and contractors with a system performance warranty.

### The Knauf System Performance Warranty ensures your Knauf systems are:

- Designed to perform to the agreed specification throughout the lifetime of the building provided that systems remains as per original design and intent\*
- Fully supported by Knauf Technical Services both pre-site and during construction
- Repaired or replaced by Knauf in the unlikely event of system failure due to product/ system defect.

All of our systems are covered by our comprehensive Knauf System Performance Warranty, giving you the assurance that the systems you specify and install will perform to specification.

*\* Note there are some components within specialist system/s that may require inspection as part of project maintenance plan.*

## BIM Specification Experts

We have our BIM in house design team to support you with all of your design specification needs.

Building Information Modelling (BIM) is a way to digitally present the information about every component in a building. It allows architects, designers, engineers and other construction professionals to access the information and get a whole picture of the design, to reduce risks or mistakes. It can also be used to manage building facilities after completion.

### What is a BIM Object?

BIM objects are representations of products that contain product properties, physical characteristics and functional data that can be imported into design software.

We provide free BIM objects for our products and systems. These can be accessed at the NBS National BIM Library at [source.thenbs.com](http://source.thenbs.com)

## Knauf Planner Suite

The Knauf Planner Suite specification tools platform is a highly efficient project design tool. Connected to our state of the art product and system search function, data validation and bill of quantities template creator, it offers you an integrated solution that supports you at all stages of your planning journey.

To deliver the best experience across all touchpoints, the Knauf Planner Suite can be accessed either via the Planner Suite Systemfinder (web application) or as a BIM Plug-In which is currently available for Revit and ArchiCAD.

Knauf Planner Suite can be found on our website: [discover.knauf.com/en-gb/planner-suite](http://discover.knauf.com/en-gb/planner-suite)

## Technical Service Support Team

Our Technical Services team can provide help and support throughout your project, whether you are a contractor, distributor or architect.

Our office based Technical Support Officers (TSOs) work hand in hand with our PSM team, providing design back-up and a quick response to all your technical enquiries. Our TSOs are all technically qualified and enjoy comprehensive and ongoing training. Our commitment to investing in people has resulted in a large number of TSOs going on to become PSMs in the field, and the two teams have an excellent working relationship – enhancing the level of service you can expect from us.

For queries, please email [technical-uk@knauf.com](mailto:technical-uk@knauf.com)

### What We Offer:

- Expert technical support and guidance
- Project Specifications
- Design support and typical detail packs
- U-value calculations (calculated by the combined method, in accordance with the conventions detailed in BRE 443 (2006), BS EN ISO 6946:2017)
- Deflection calculations for our partitions and linings
- Eccentric Loading Calculations for our partitions and linings.



## AQUAPANEL® CPD's

We are part of the RIBA CPD Providers Network



### Continuous Professional Development

We offer Continuous Professional Development (CPD) seminars. Our specification experts present presentations which include up to date knowledge on the industry standards and legislation such as 'Knauf AQUAPANEL® Outdoor: Boarded Cladding - Certainty from design'.

Our team of experts present both RIBA-approved seminars, and Knauf Product / system specific CPDs. Our CPD seminars will give you cutting edge knowledge to help generate ideas, designs and specifications.

Knauf is renowned globally for its experience in the industry which covers almost 90 years, since the inception of Knauf Gips in Germany. We have helped design thousands of construction projects working alongside architects and project design teams.

Want to find out more and book our RIBA Approved AQUAPANEL® CPD Seminar.



## Built on Experience

In a fast-changing world, Knauf AQUAPANEL® Cement Board Outdoor Technology delivers creativity, certainty and complete peace of mind whatever the building type – from houses, offices and high-rise residential accommodation through to hospitals and stadia.

Challenging the dominance of brick and block, Knauf AQUAPANEL® Cement Board Outdoor is helping shape some of the world's most ambitious and breath-taking projects, including the Allianz Arena (Munich), the Chinese Opera House (Xiqu Centre) in Hong Kong, the Eagle in Flight (Tirana) and the 'A House' in Yongin (South Korea).

Knauf AQUAPANEL® Cement Board Outdoor doesn't just build on the skills and experience of architects. It helps them step away from traditional thinking and conventional construction methods – and to build inspirational spaces for the world to enjoy.

As a complete and lightweight boarded system, it sets a new standard for strength, versatility and performance. It can be shaped and curved into endlessly imaginative designs. It can carry a wide range of finishes – directly applied render, brick slips, cladding and external tiles, creating long lasting decorative cladding.

Its lightweight properties mean it can be used as cladding to modern MMC / OffSite structures to create extensions.

The lightweight properties also make AQUAPANEL® Cement Board Outdoor suitable as part of a refurbishment of existing buildings to extend their service life.

Based on years of Knauf Drywall technology understanding, Knauf AQUAPANEL® Cement Board Outdoor brings drywall system advantages to the outside of the building. Easy to work with, creating safe and speed construction in both on and off site applications.





## Case Study September 2019

### Modular-Build Showroom, Graven Hill, Oxfordshire

**Project outline:** Graven Hill is the largest custom and self-build community in the UK, where up to 1,900 new homes, shops, cafes, pubs and a new school are set to be delivered over 10 years.

**Modular Builder:** Ecofast Systems Ltd.

**Products:** Knauf AQUAPANEL® Cement Board Outdoor with the interior products of Knauf metal partition C Studs, Knauf MF Ceiling system, Knauf Wallboard, Knauf Moisture Panel with associated taping and jointing products.

**Summary:** New showroom at Graven Hill development featuring many Knauf interior and exterior components, including ceiling, partitioning and façade systems.

### Full Knauf Specifications on Modular-Build Showroom at Graven Hill.

Modular builder Ecofast Systems Ltd. is proud to unveil its new showroom at the new Graven Hill development near Bicester in Oxfordshire featuring many Knauf interior and exterior components, including ceiling, partitioning and façade systems.

Graven Hill is the largest custom and self-build community in the UK, where up to 1,900 new homes, shops, cafes, pubs and a new school are set to be delivered over 10 years. The new village has already started taking shape and has attracted considerable interest, including from well-known TV show Grand Designs.

### Knauf solutions for offsite/modular construction projects

Paul Gladman, Director at Ecofast Systems Ltd. commented: "We chose to use Knauf as we feel they are the best products on the market, especially Knauf AQUAPANEL® Outdoor which works well with our modular construction system."

Knauf partnered with the Modular & Portable Building Association (MPBA) and the Structural Timber Association to help make it easier for specifiers to find the quality solutions they need for projects which employ offsite construction methods.

### Houses ready in three days with high quality materials

Ecofast Systems Ltd. decided to specify Knauf AQUAPANEL® Cement Board Outdoor with the Knauf metal partition C Studs, Knauf MF Ceiling system, Knauf Wallboard and Knauf Moisture Panel with associated taping and jointing products.

Paul added: "We have very much enjoyed using Knauf products. For Ecofast Systems Ltd., our most important priorities are speed, cost and quality so we needed a solution that would help us achieve those aims. Our modular system can deliver an entire house structure in just three days and using Knauf products meant we have been able to achieve fast finishing timescales."

Knauf AQUAPANEL® Cement Board Outdoor is a robust, impact-resistant and A1 non-combustible exterior render substrate which can be used as a high-quality economical alternative to traditional building methods such as brick and block. Once installed, taped and jointed, Knauf AQUAPANEL® Outdoor can be left for up to six months without applying the finish, allowing the internal fit out to start prior to completion of the cladding or render finish – ideally suited for offsite or custom and self-build construction projects.

***"We have very much enjoyed using Knauf products. For Ecofast Systems Ltd., our most important priorities are speed, cost and quality so we needed a solution that would help us achieve those aims."***

Knauf plasterboards are durable and versatile plasterboards as well as quick and easy to install. Knauf Moisture Panel, a high performance plasterboard, is able to withstand areas of high humidity such as kitchens, bathrooms and toilets.

For more case study examples visit:  
[knauf.co.uk/project-showcase](https://www.knauf.co.uk/project-showcase)

# A higher return on investment

The lightweight nature of Knauf AQUAPANEL® Cement Board Outdoor doesn't just help deliver efficient and economical builds, it delivers significant financial benefits too, both in terms of construction costs and rental or resale value.

## Lower construction costs

Because Knauf AQUAPANEL® Cement Board Outdoor Technology is a lightweight solution, there is significantly less bearing load in both primary construction and foundation works. Traditional block and render is both thick and heavy, needing its own foundation; where, Knauf AQUAPANEL® Cement Board Outdoor with a modern thin coat render will be fixed to the structure, at a far lighter weight, without the need for its own foundation. As a result, the building design and its construction can be executed much more cost-effectively.

Weight for weight, Knauf AQUAPANEL® Outdoor solutions also cost less to transport and to store on site than traditional building materials such as blocks, while the speed of installation reduces the extended need for scaffolding, helping cut construction prelim costs. Equally, the use of drywall solutions eliminates water use, while a faster drying time minimises the amount of energy needed to dry out the construction. These advantages drive cost benefit into the project right from the start.



## Benefits of AQUAPANEL® Outdoor on construction sites

- Reduces the number deliveries needed to site, unlike brick and block, reducing environmental impact made by excessive delivery vehicles.
- AQUAPANEL® can be stored outside and takes up a lot less space than conventional building products.
- Reduces site storage space, 2 pallets of AQUAPANEL® = Approx. 13 pallets of block products.
- Water reduction usage as no mixing of mortar for block and brick work, and water hungry thicker renders. Taping and jointing and modern thin coat renders use far less water.
- When taped and jointed using Knauf AQUAPANEL® Outdoor Joint Filler Grey and Knauf AQUAPANEL® Tape, the facade is temporarily weather resistant and wind tight.
- Can easily curved down to 1m without the need of tools or machinery.
- Easy to cut, snap and fix using Knauf Aquapanel Screws.

Increased sale and rental value with AQUAPANEL® Outdoor, it is possible to build your rendered facade to a MMC (timber frame, SIP or steel frame structure) using Knauf AQUAPANEL® Outdoor instead of block and render, meaning that more internal floor space is available for sale or for rent.

Shown below how much of the area occupied by the exterior walls in traditional ways of construction can be converted into usable, productive space by using AQUAPANEL® Cement Board Outdoor.

Considerably faster construction and finishing means that a sale – or rental return – can be achieved faster than with traditional construction methods. Both factors combine to ensure a faster and higher return on investment.

AQUAPANEL® Outdoor can increase the internal floor space of your building.

If a building was 80m<sup>2</sup>, using AQUAPANEL® instead of traditional brick and block would gain you approximately and additional 4m<sup>2</sup> of internal space.

It is possible to increase the available internal floor space by up to 5% when switching the outer cladding to the MMC / OffSite structure from blockwork and traditional renders to Knauf AQUAPANEL® Outdoor and Thin Coat Renders.

*(figures based on an average calculation of footprint and wall thickness on typical UK house figures above)*

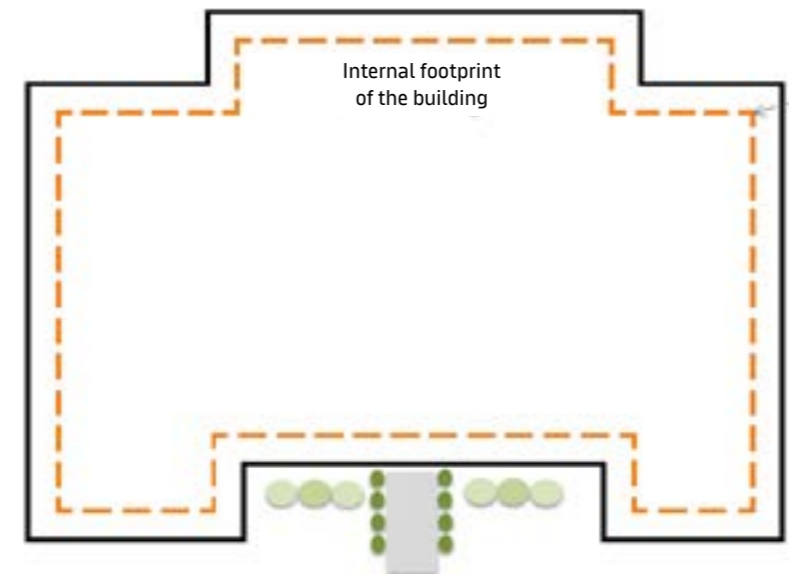

### Timber frame / SIP with block work and render in (mm)

Timber frame structure	
Wall cavity	50
Block work	100
Block work render system	15

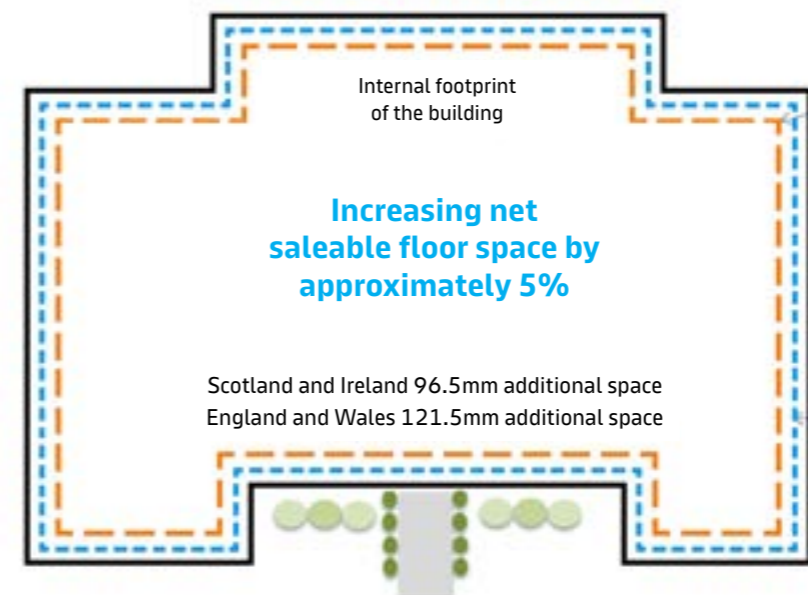

### Timber frame / SIP with block work and render in (mm)

Timber frame structure	
Wall cavity	50
Block work	100
Block work render system	15

### Timber frame / SIP with block work and render in (mm)

Timber frame structure	
Render Cavity	50*
Knauf Aquapanel Exterior	12.5
Render finishes	6

**Increasing net saleable floor space by approximately 5%**

Scotland and Ireland 96.5mm additional space  
England and Wales 121.5mm additional space

\*50mm for Scotland and Ireland, 25mm for England & Wales

# Creative Freedom Without Limits

In today's construction environment, there is a drive to reduce the impact of the building on human health and the natural environment.

In our modern world clients and architects want to create softer and individual buildings and features, using Knauf AQUAPANEL® Outdoor it is possible to create curves and twists without expensive or pre-formed cladding.

This must be considered at every stage of the process, from planning and design through to construction, use, renovation and demolition. Finishing the exterior cladding using Knauf AQUAPANEL® Cement Board Outdoor when considering curves and twists is simple - once the structure has been built the cladding will follow what is behind.



# New design possibilities for curved walls

With a bending radius of 3 metres (full board) and 1m (300mm strips), AQUAPANEL® Cement Board Outdoor allows designers to introduce a variety of curved shapes and creative designs, including domes and arches.

It is possible to create curves in both concave and convex directions, as well as twists using Knauf Aquapanel® Cement Board Outdoor. Once the boards are fixed to the rigid shaped structure behind, they remain in the shape ready for finishing.



## Arrangement of Knauf AQUAPANEL® Cement Board Outdoor with different radius

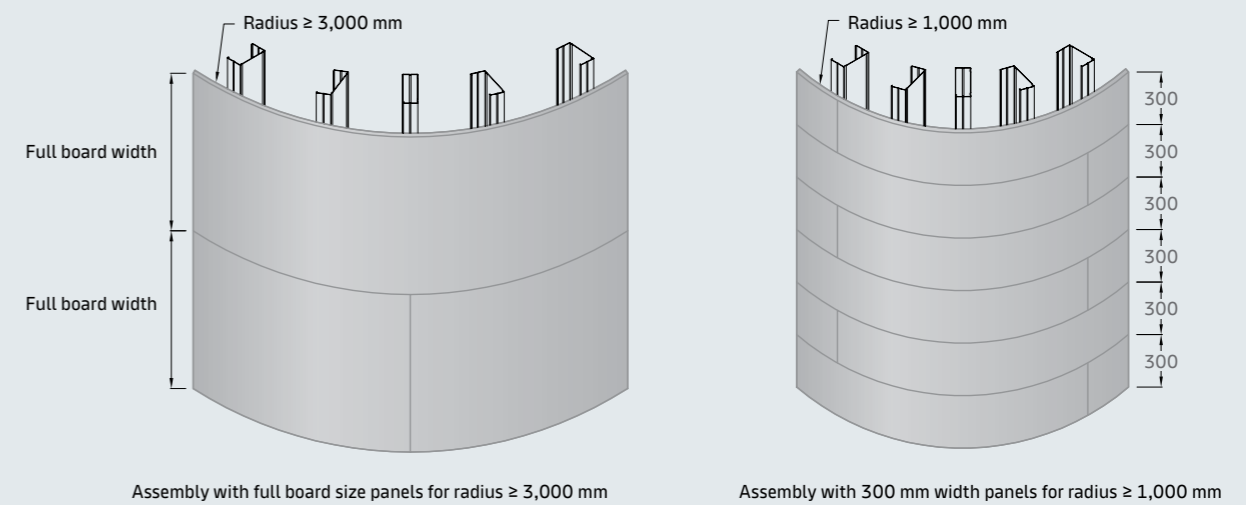

Boards shown fixed directly to studs as example - not suitable for UK exterior applications

# Knauf AQUAPANEL® Cement Board Outdoor System

Knauf AQUAPANEL® Cement Board Outdoor is used as part of an exterior system for use on timber frame, SIP systems and metal framed structures, installed to battens or helping hand brackets creating a drained and ventilated cavity (top and bottom) rain-screen system. The system provides a fast, high quality and extremely economical alternative to traditional methods of construction.

## A cross battened system is most commonly needed to:

- Push the boarded cladding away from the structure to align with other cladding.
- When the vertical battens behind the Knauf AQUAPANEL® Cement Board Outdoor need to be closer together than the structure frame.
- To allow for supporting the boards in areas of high impact (schools, stadiums, high traffic area) where battens behind the Knauf AQUAPANEL® Cement Board Outdoor should be at 300mm centres.
- In high wind load environments, where battens behind the Knauf AQUAPANEL® Cement Board Outdoor should be at 400mm centres. We can assist in advising further if you believe that you have a need for this sort of system, refer to Knauf Technical for assistance.
- With battens or brackets at 600mm centres, Knauf Aquapanel Exterior can take cladding up to 40kg/m<sup>2</sup>. "Bringing battens closer can enhance the cladding weight limit." (Refer to Knauf Technical for cladding heavier than this).



## Knauf AQUAPANEL® Cement Board Outdoor

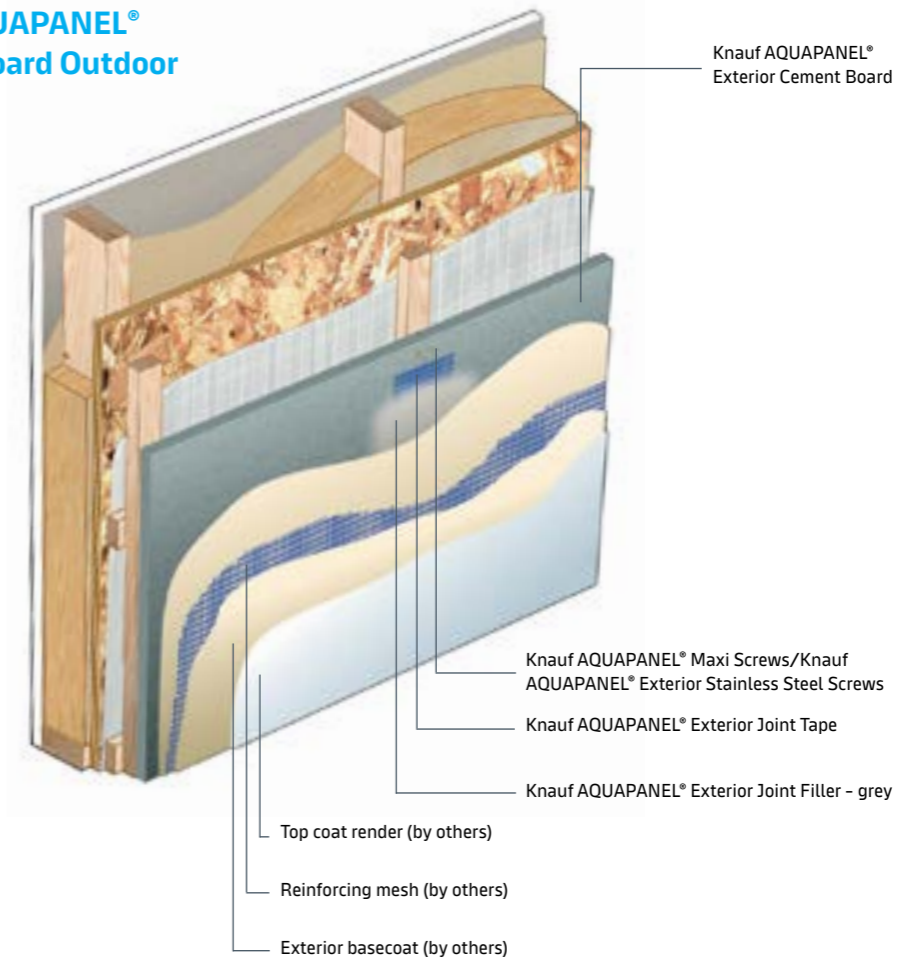

## Knauf AQUAPANEL® Cement Board Outdoor as a finishing option to the Knauf Throughwall System

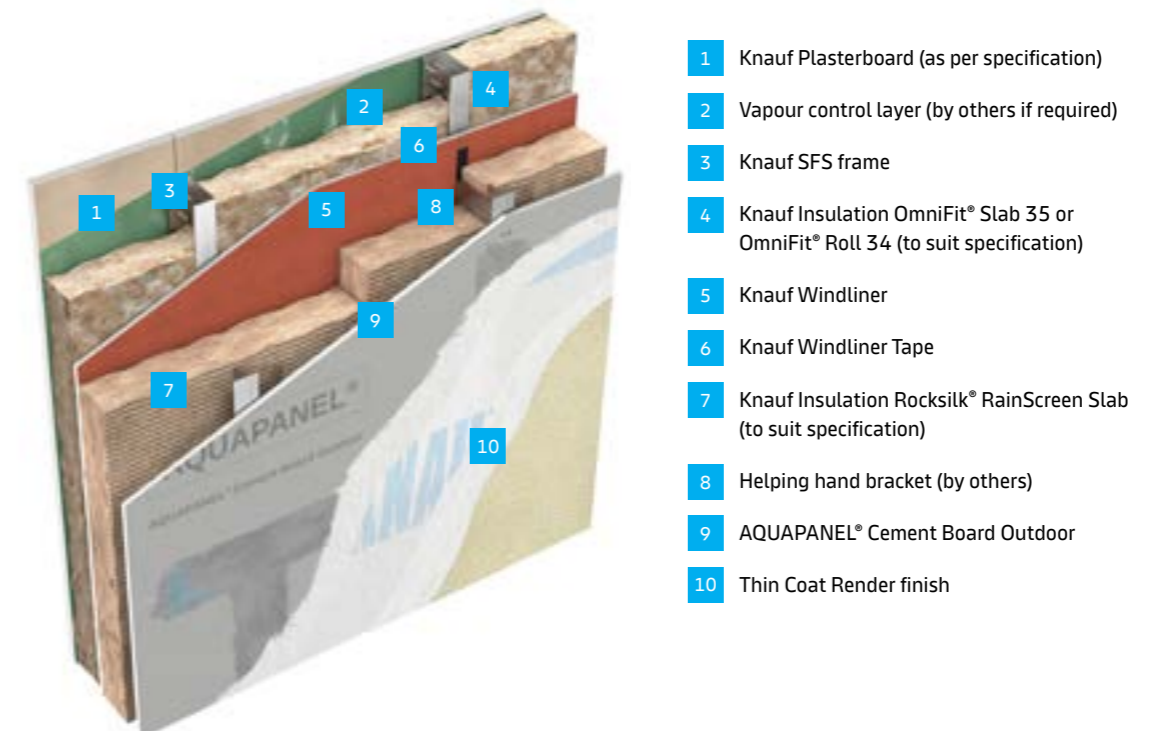

**Note:** Consult Knauf Technical Services to ensure system is checked for suitability of project.

\*The various cladding and associated components must be checked to ensure the required testing and regulatory conformity are met.



## Case Study February 2017

### Abbeyfield Winnersh Care Home

**Project outline:** Contractors specified Knauf AQUAPANEL® Cement Board Outdoor early in the design process of a 60-bed care home in Winnersh, leading to significant time and cost savings.

**Architect:** Edmund Williams Architects

**Main Contractor:** Castleoak Care Developments

**Products:** Knauf AQUAPANEL®, Exterior Cement Boards and Knauf Exterior AQUAPANEL® SN40 Stainless Steel Screws.

**Summary:** Castleoak Group was so satisfied with the Knauf AQUAPANEL® Cement Board Outdoor system used for Abbeyfield Winnersh that they specified it again for another larger care home.

**Early specification of Knauf AQUAPANEL® at the design stage of a 60-bed care home in Winnersh has provided both speed and cost savings for specialist care home developers Castleoak Group.**

By utilising the lightweight performance of the Knauf AQUAPANEL® Cement Board Outdoor panels, compared to brick and block construction, designers were able to reduce the size and weight requirements of the foundations.

Castleoak turned to Knauf to create an imaginative faceted façade in Winnersh near Wokingham for care operator Abbeyfield.

The Abbeyfield Winnersh care home is formed of four striking circular clusters that create a unique community to deliver innovative dementia care. Knauf AQUAPANEL® Cement Board Outdoor was used as a substitute façade system to brick and completed with a rendered finish. Castleoak deployed lean construction techniques to optimise the build process. Work began on site in March 2015 and was completed in April 2016.

Facing cost pressure and difficulty securing brick and block supplies, Castleoak Operations Director Neil Robins and his colleagues were charged with designing a build strategy without the use of brick. “With inhouse timber frame design and manufacturing, Castleoak was able to offer our customer a really innovative build solution”, Neil said. “The design was challenging, but we weren’t daunted. We knew we had to try something different.”

“Our solution was to prefabricate all panels, floors cassettes, and for the first time, apply external render panels at the Castleoak factory for this build. This strategy offered a great quality solution – and enabled us to better control the build programme with less dependency on sub contractors.”

The decision to use Knauf AQUAPANEL® was made easier due to its characteristics as a directly applied render carrier board.

The cement board combines the benefits of brick and block and, because it consists of aggregated Portland cement with coated glass fibre mesh embedded in the back and front surfaces, provides the ideal key for render.

Knauf AQUAPANEL® was introduced very early in the design stage allowing for further time saving. Knauf’s Specification Team assisted at the design stage where the decision was made to assemble much of the external façade system offsite. The exterior panels were constructed at the Castleoak factory before being delivered to site to be installed by Sequoia Joinery.

Morgan Palmer, Operations Manager at Castleoak was satisfied with the performance of the Knauf products on the Abbeyfield Winnersh project. “The installation of the Knauf AQUAPANEL® panels went to plan. The design and materials were well specified and performed. The programme remained on track.” Knauf AQUAPANEL® Cement Board Outdoor is ideal for offsite installation.

Factory fitting, transport and site installation has no adverse effect on its final performance. Rigorously tested and certified by the BBA for use as a ventilated exterior wall panel system on timber frame and steel frame buildings, Knauf AQUAPANEL® Cement Board Outdoor provides a solid, dry base that can withstand the extreme weathering effects of wind, rain and snow. It is also ideal for creating exterior soffits and the illusion of an internal ceiling continuing through the façade to the outside of the building.

# Installation procedure

## Preparation

**1** Use a knife to score the Knauf AQUAPANEL® Cement Board Outdoor on one side so that the mesh is cut. Snap the scored edge and cut through the mesh on the rear side.

For sharp-edged cuts, for example exterior edges, use a hand-held circular saw with a dust extractor or a pendulum jigsaw. To make cut-outs for wiring and pipes, use a jigsaw or keyhole saw.

The diameter of the opening should be approximately 10mm greater than the diameter of the pipe. The remaining gap can be closed with a suitable sealant or sealing strip.

Knauf AQUAPANEL® Cement Board Outdoor can be curved to a radius of 3 metres with a full board or to a 1 metre radius having cut the board into 300mm strips. Bend the Knauf AQUAPANEL® Cement Board Outdoor panel prior to installation. The fine cracks that occur on the board surface will not cause any loss of performance to the final system when finished to a basecoat level.

## Fixing Board

**2** Apply Knauf AQUAPANEL® Cement Board Outdoor horizontally to members at maximum 600mm centres (or to suit project specification). Ensure there is a gap of 3–5mm between the boards and that the members are central behind both boards.

Aquapanel Outdoor Boards are recommended to be installed smooth side out, with Aquapanel branding visible.

When fitting Knauf AQUAPANEL® Cement Board Outdoor, ensure that the vertical joints are centrally aligned to the board below.

When fitting Knauf AQUAPANEL® Cement Board Outdoor around windows and doors ensure that no vertical joints coincide at window and door corners as this may allow moisture ingress.

Use Knauf AQUAPANEL® Maxi Screws to fix the boards to metal members.

Use Knauf AQUAPANEL® Cement Board Outdoor Stainless Steel Screws to fix the boards to the timber members.

Screws should be at least 15mm in from the edge of the Knauf AQUAPANEL® Cement Board Outdoor and spaced at maximum 250mm centres.

Screws should not be over tightened.

## Taping and Jointing

**3,4** Immediately after installing the Knauf AQUAPANEL® Outdoor, protect the framework from weathering by filling all the joints with Knauf AQUAPANEL® Outdoor Joint Filler – Grey. Use the Knauf AQUAPANEL® Outdoor Joint Filler – Grey to fill the gaps between the board and then spread it over the face of the board ready to take the tape. Immediately embed Knauf AQUAPANEL® Outdoor Joint Tape (10cm) or Knauf AQUAPANEL® Outdoor Reinforcing Tape – as specified, centred over all of the joints. Scrape the excess Knauf AQUAPANEL® Outdoor Joint Filler – Grey from the Knauf AQUAPANEL® Outdoor Tape leaving it just covered.

Cover the screw heads with Knauf AQUAPANEL® Outdoor Joint Filler – Grey.

Corners are protected by applying exterior basecoat, then embedding a corner profile in a similar way to the joint tape.

Reinforce window and door corners with extra pieces of reinforcing mesh, cut to size 50 x 30cm, embedded into exterior basecoat as per corner profiles.

## Finishing

Refer to installation instructions from the selected/specified render supplier, alternatively:

**5,6,7** Cover the entire wall with basecoat to a depth of approximately 5mm.

Using a tile adhesive trowel create a notched layer of basecoat with notch depth of approx 8mm. Return the removed basecoat to the bucket to be reused later.

Embed reinforcing mesh over the entire surface. Overlap the reinforcing mesh by 100mm at edges. Apply a thin coat of basecoat over the mesh and notches just covering the mesh and creating a smooth finish. The finished layer should be approximately 5–7mm thick and the reinforcing mesh should be in the top third of the finished surface. Before continuing with the next steps, allow the basecoat to fully dry.

## Exterior Render (by others)

**8** Render must be applied in accordance with BS EN 13914-1:2016, Code of Practice for External Rendering.

Primer should be applied in line with manufacturer specifications or recommendations prior to top coat application.

Fully mix the renders before applying them to ensure that the colour is true right through. Apply the chosen exterior finish to each wall area.

The scaffold around the finished wall must be covered to protect from rain or weathering until the finish is fully dry.

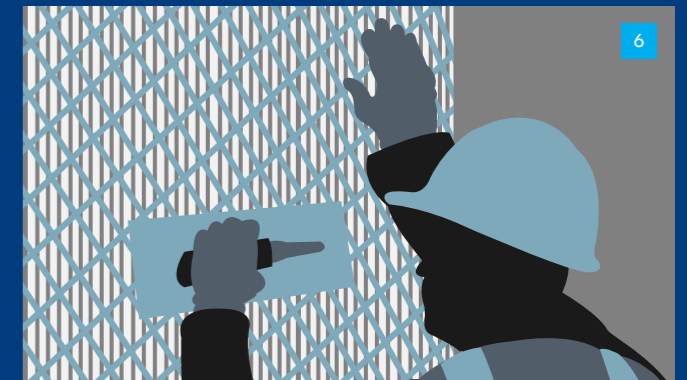

# Application details

## Horizontal Expansion JointFrame

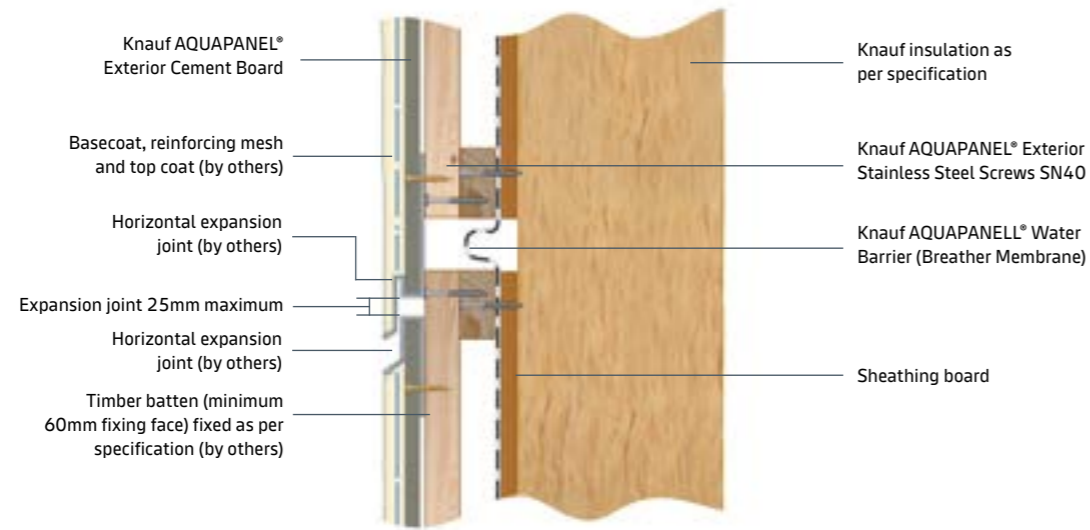

**Note:** Horizontal and vertical movement joints required at 15m spans (maximum) or to match movement joints in the substrate behind

## Window Jamb – Ventilated Wooden Frame

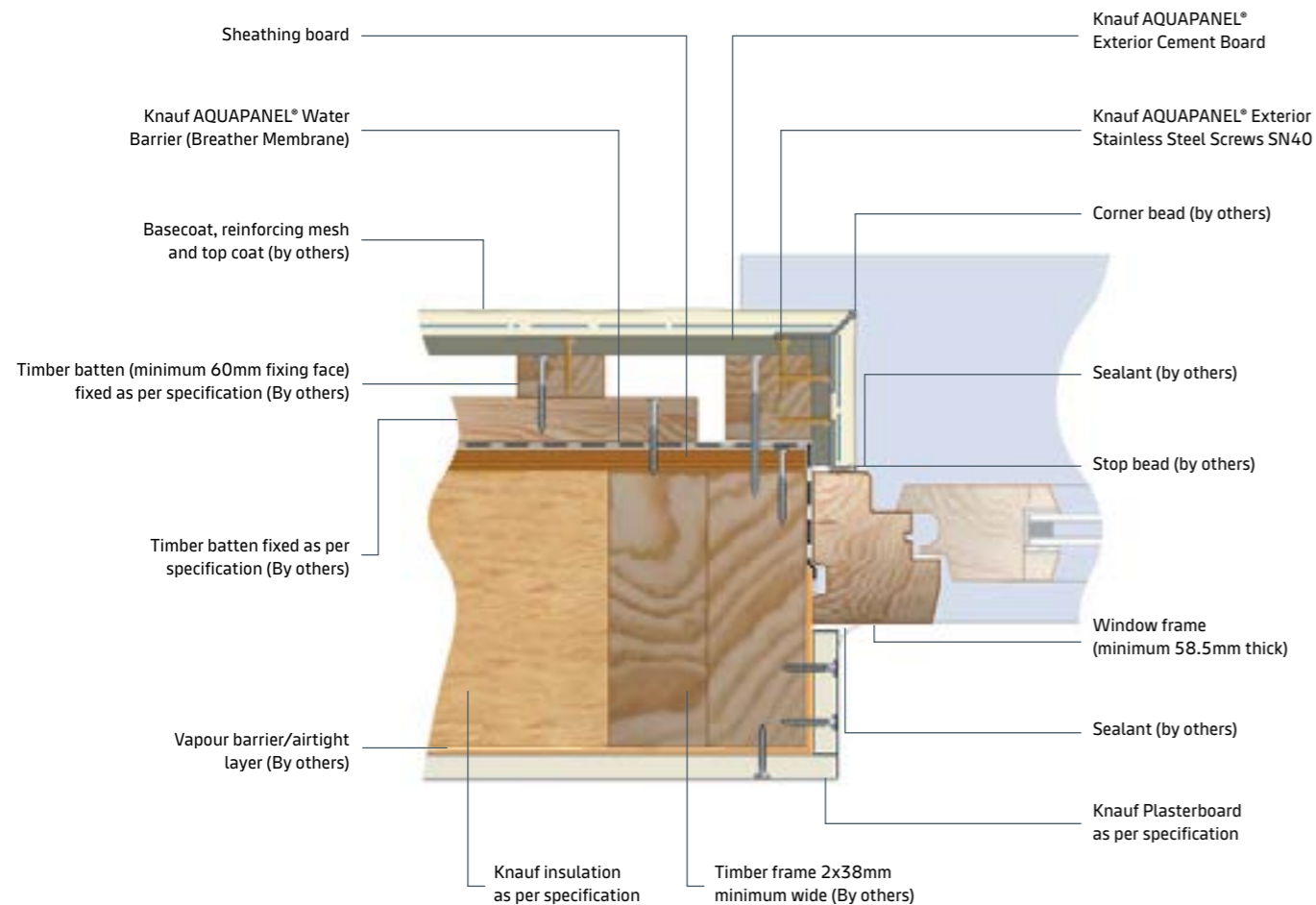

## Window Reveal (Upper) – Ventilated Wooden Frame

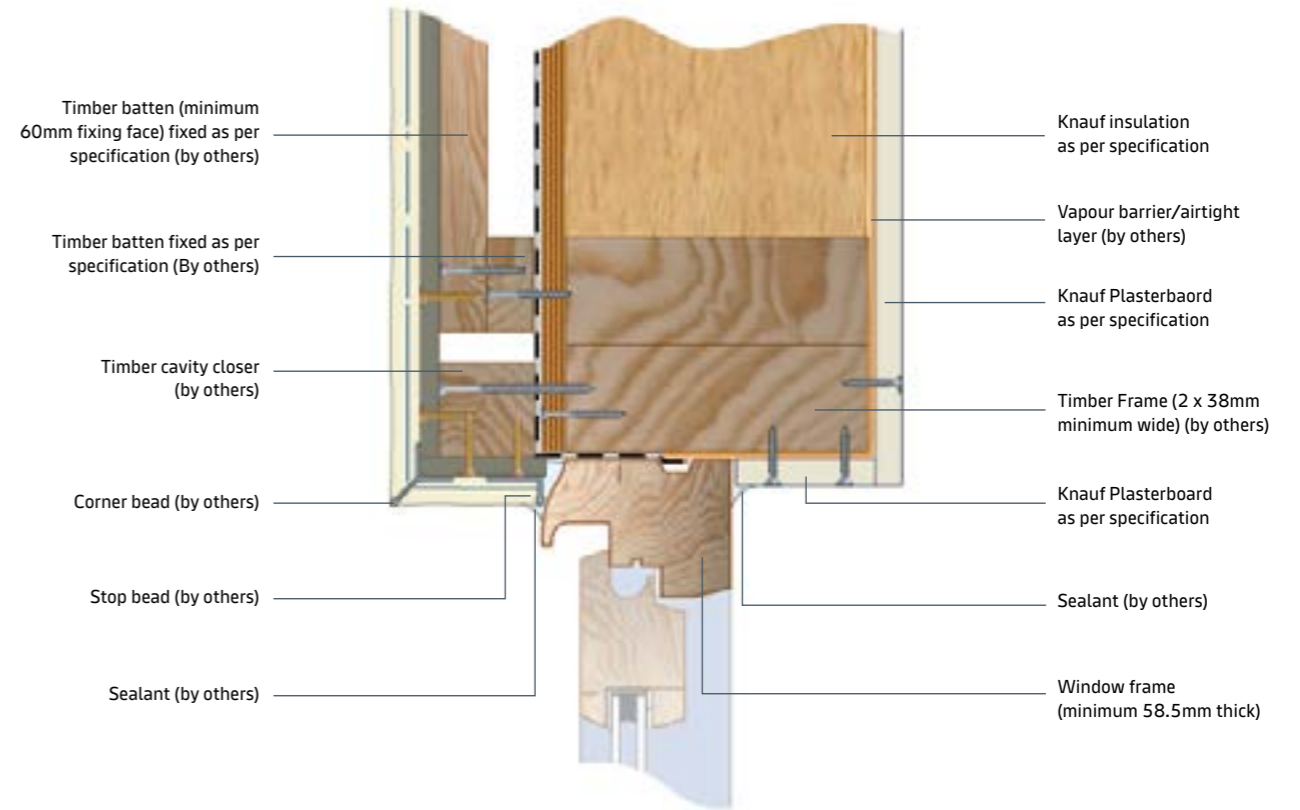

## Window Reveal (Lower) – Ventilated Wooden Frame

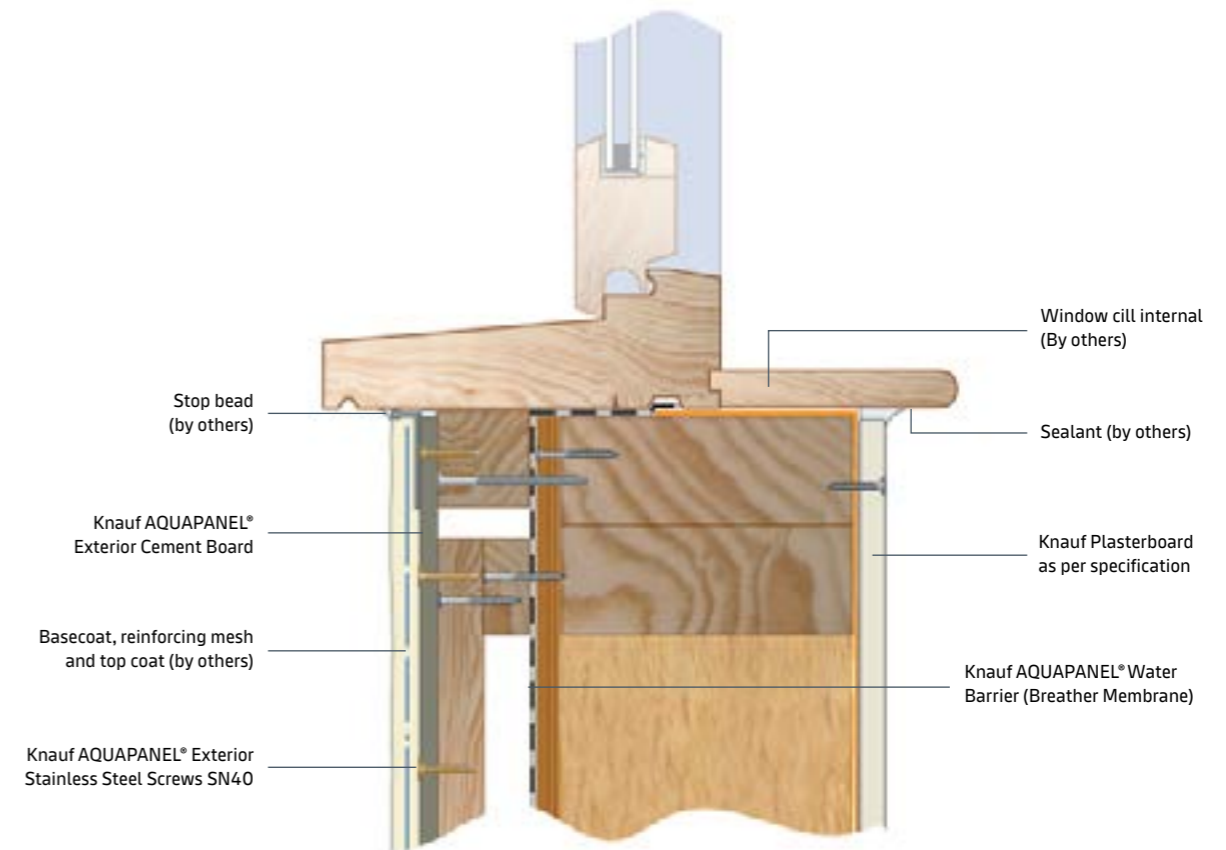

## Application details

### Base Formation

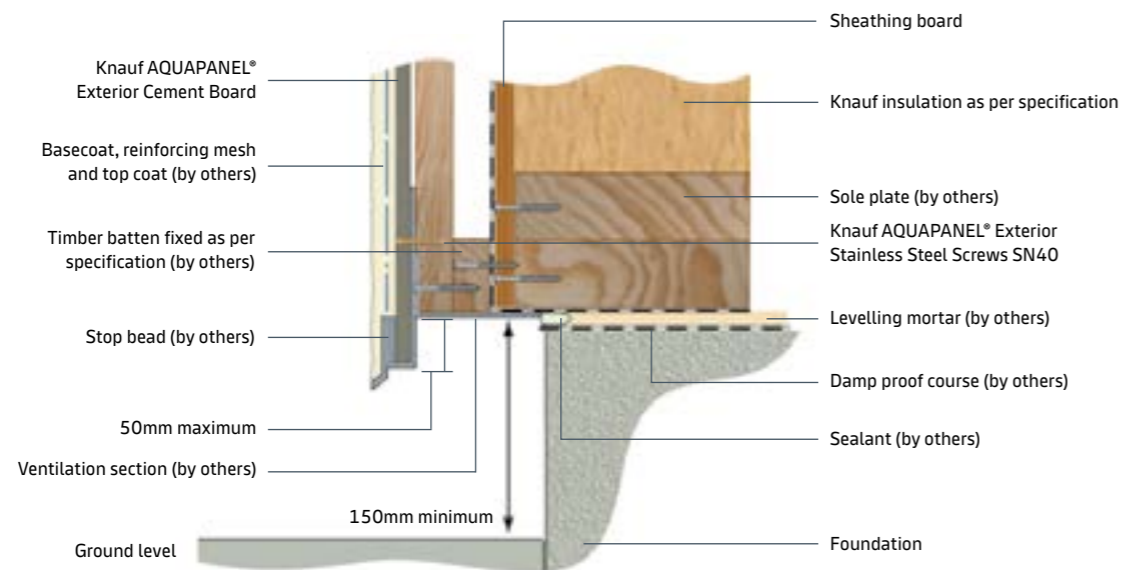

### Eave Formation

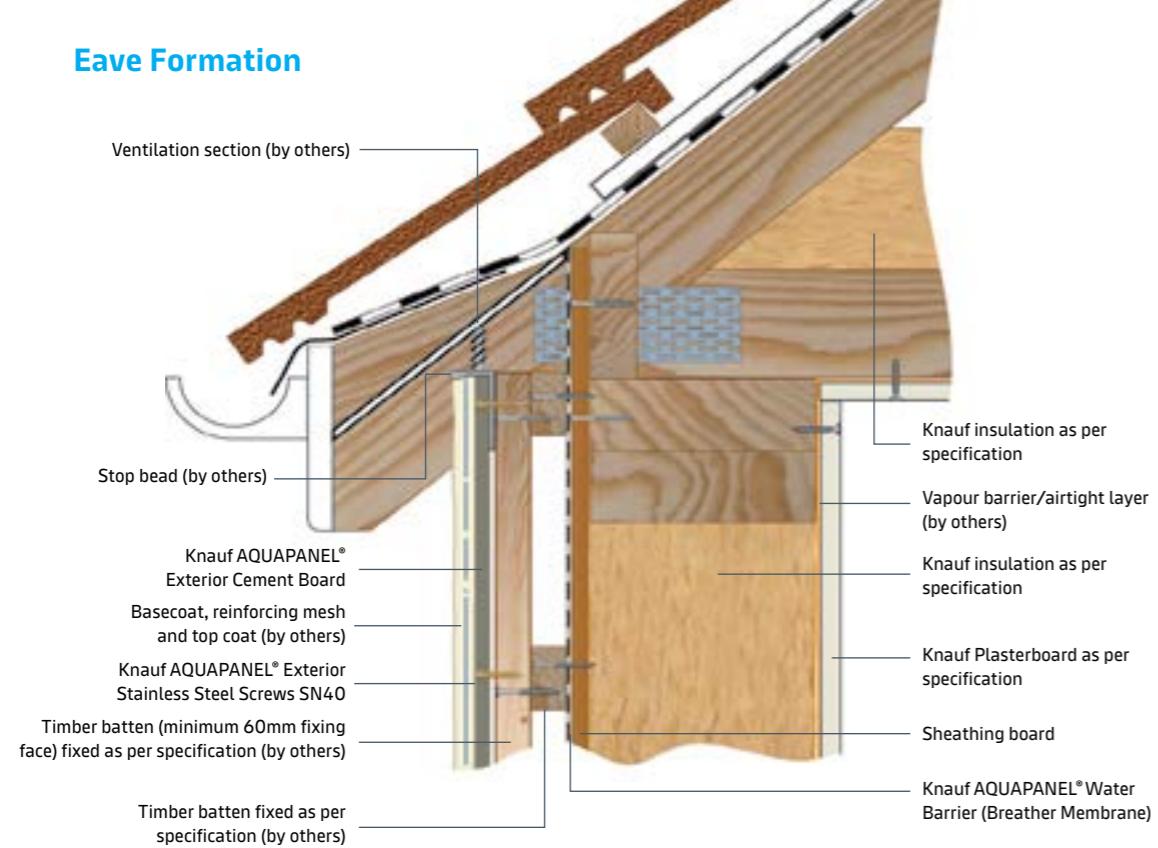

## Vertical Fixing Joint

### Window Reveal (Upper) – Ventilated Wooden Frame

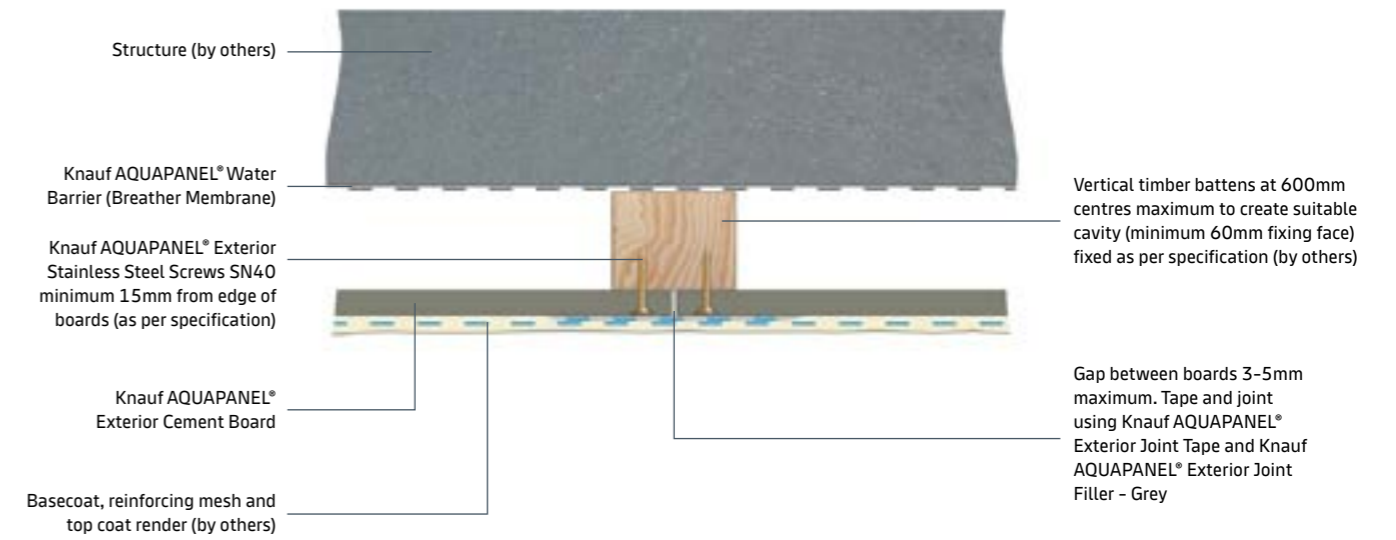

### Horizontal Fixing Joint

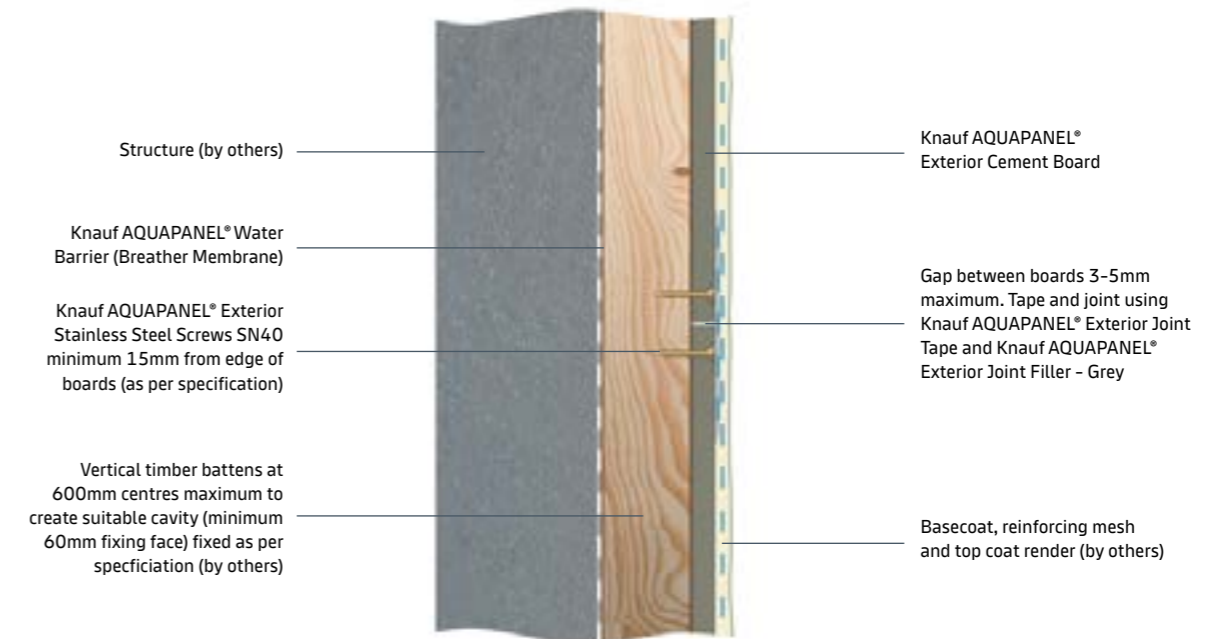

## Fixing Details

### Intermediate fixing detail

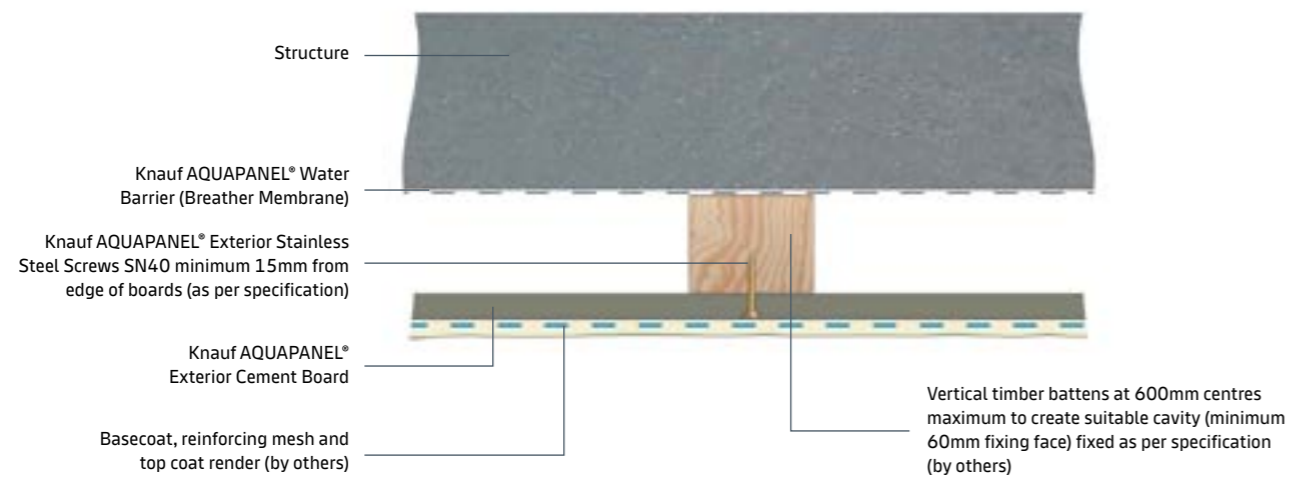

### Fixing spacing detail

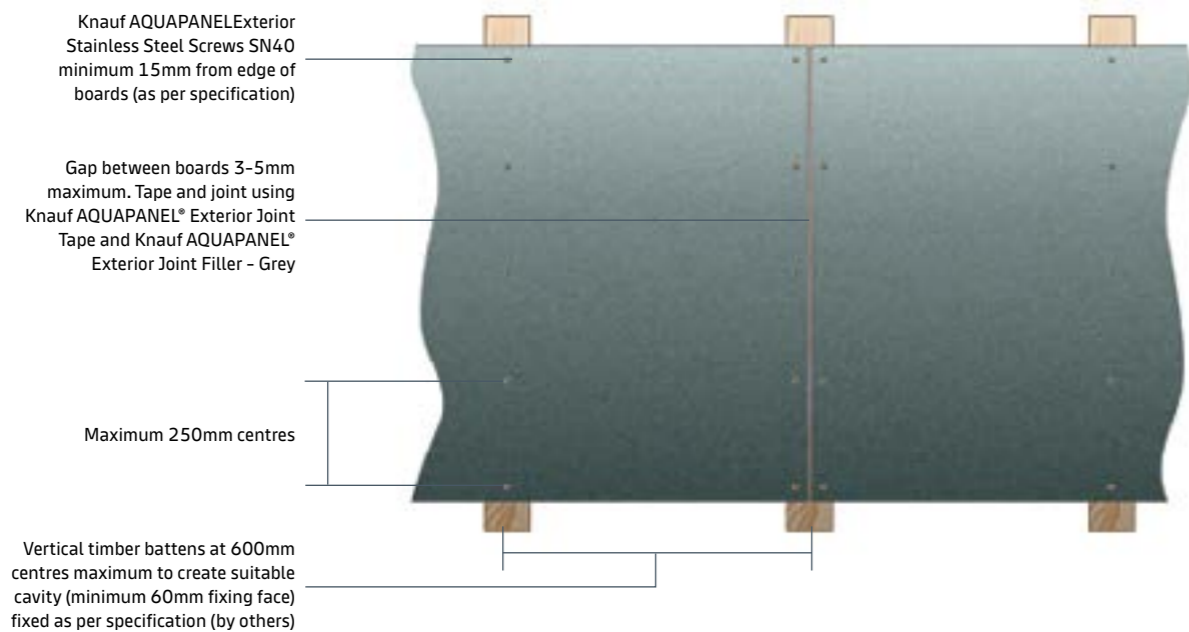

### Window Reveal (Upper) – Ventilated Wooden Frame

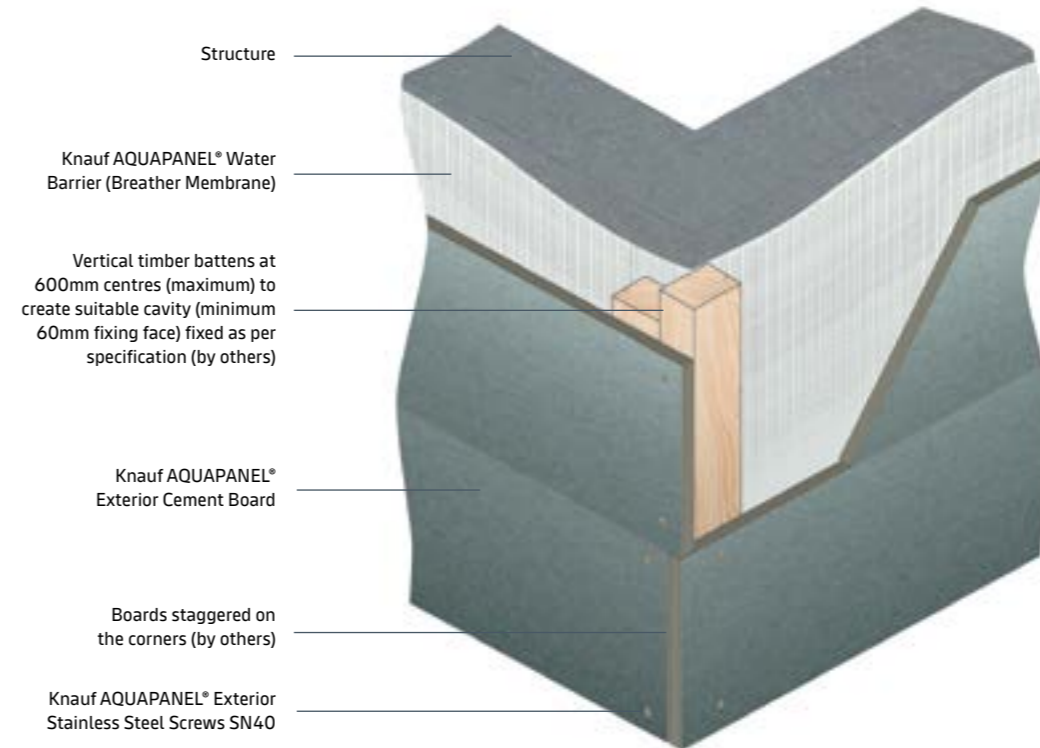

**Note:** Gap between boards 3-5mm maximum. Tape and joint using Knauf AQUAPANEL® Exterior Joint Tape and Knauf AQUAPANEL® Joint Filler - Grey.

### Window ventilation and reinforcing detail

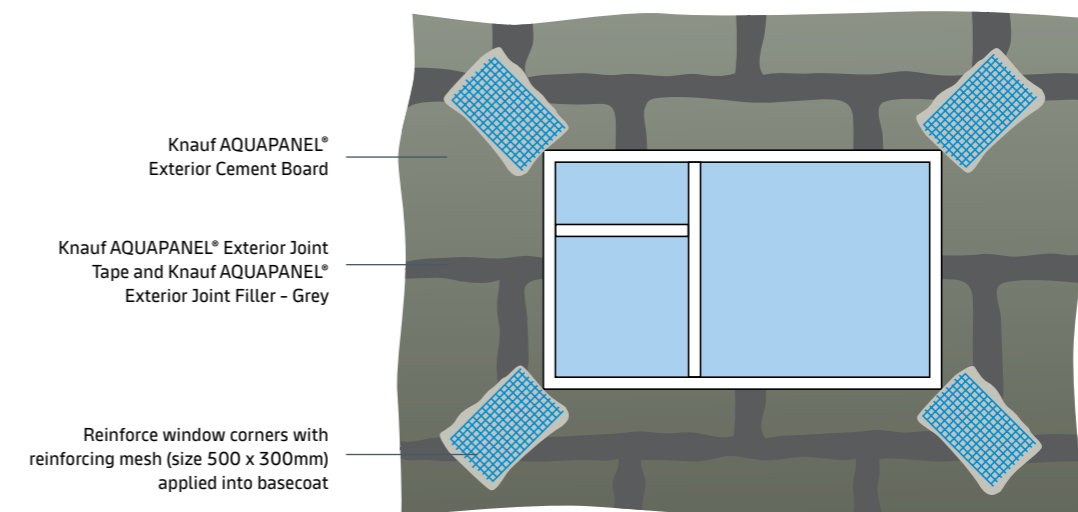

## Fixing Details

### Battening around windows detail

To allow clear drained and ventilated cavity flow

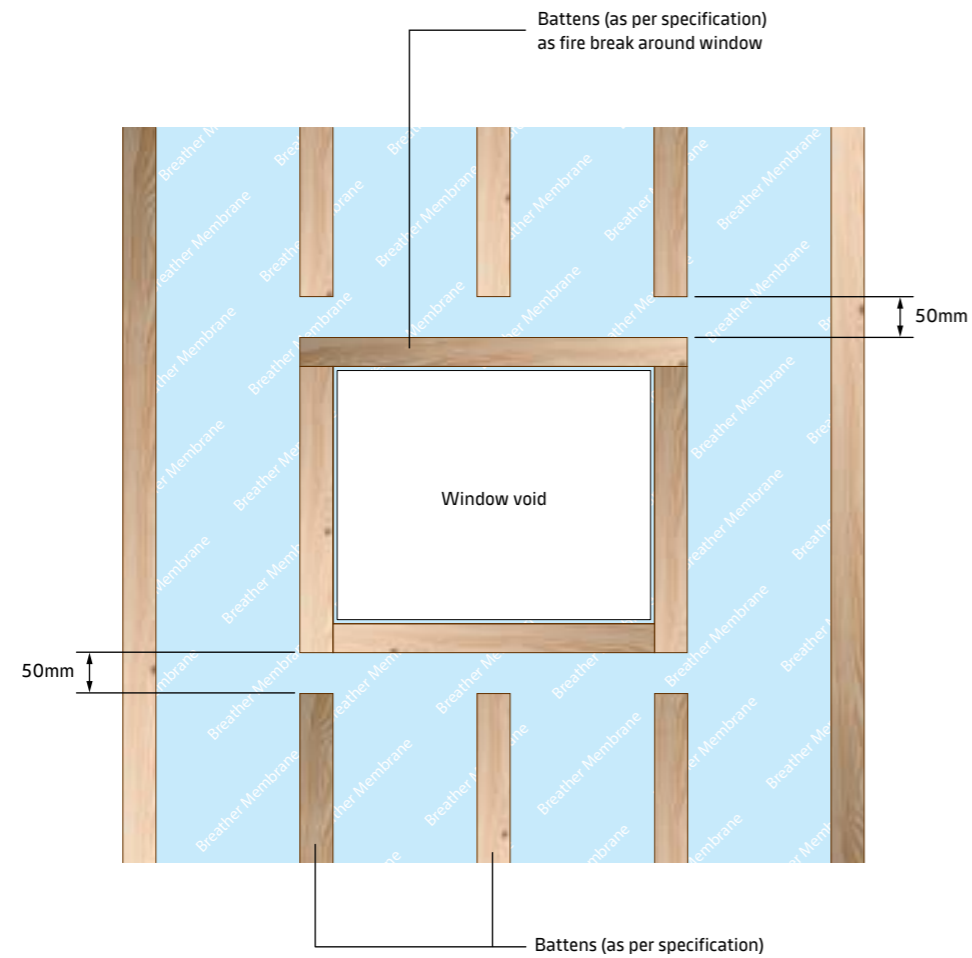

### Down onto roofline detail

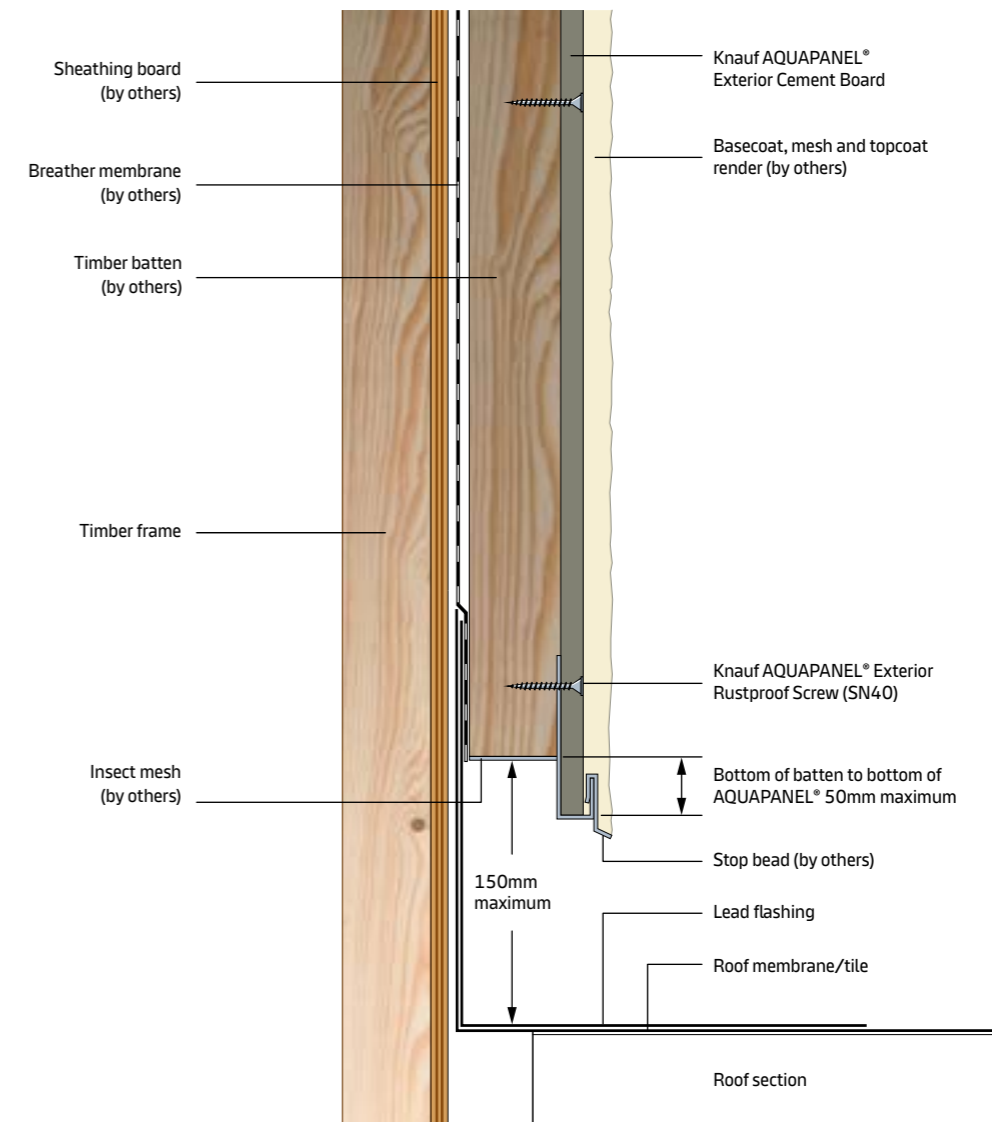

## Fixing Details

### Base formation detail

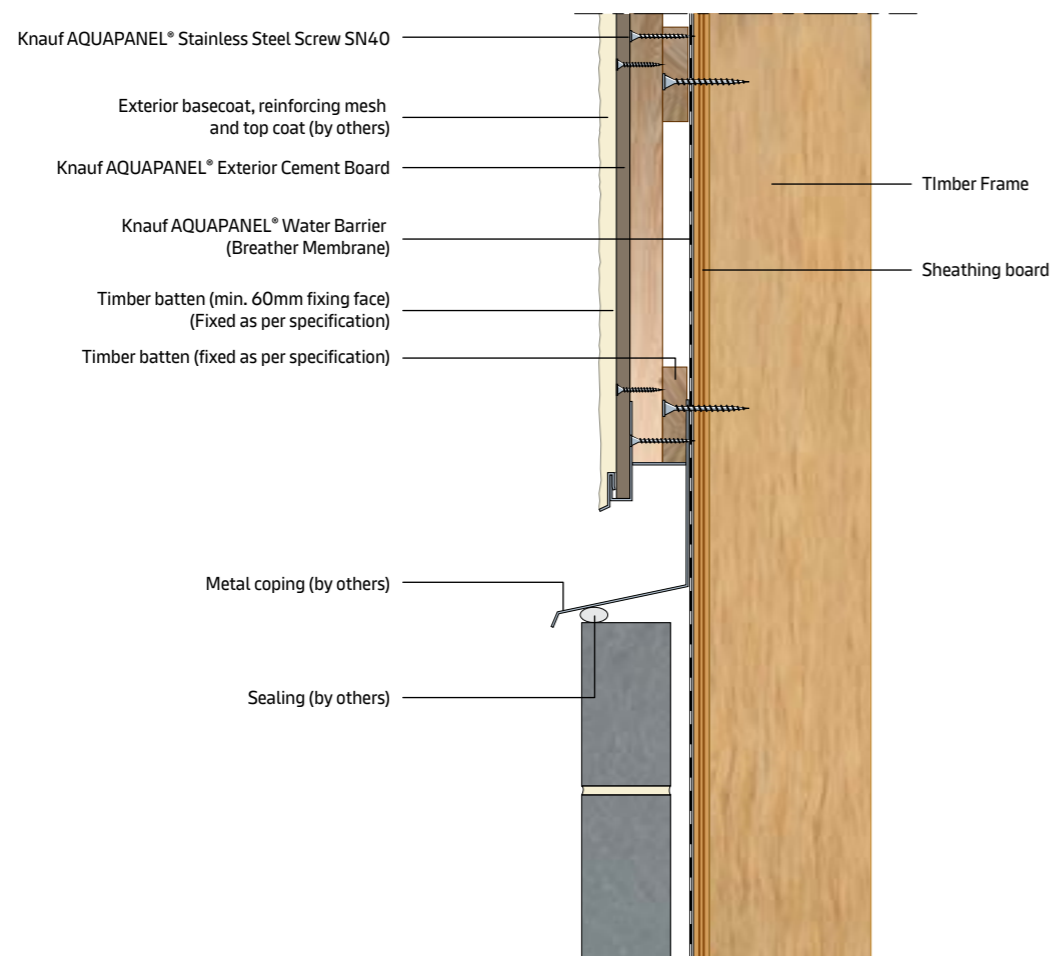

\*minimum gap between cladding and coping = 15mm + expected shrinkage

For additional detailing onto different substructures please contact Knauf Technical Services: [technical-uk@knauf.com](mailto:technical-uk@knauf.com)

## Drained and vented cavity

When building with Knauf AQUAPANEL® Cement Board Outdoor, new build insurance providers insist on an open drained and ventilated cavity from the top to the bottom of the clad wall. It is therefore important to use fire protection products and systems that do not block or fill this drained and ventilated cavity horizontally, other than when needed (in the event of a fire).

Creating a vertical fire break can be achieved with a normal full fill cavity barrier, it is recommend that it is also fixed back to the frame to stop slumping.

Horizontal fire breaks are created using an Intumescent fire strip, a thin strip that expands at a certain temperature to fill the cavity and stop flames and smoke travelling up beyond.

All fire stopping systems by others.



# Knauf AQUAPANEL® Exterior Ceiling System

**Knauf AQUAPANEL® Exterior Ceiling System is a high-performance, economical and sustainable solution for dry lining style construction of exteriors.**

From external soffits, underpasses or open and underground car parks to exterior ceilings, our solutions are engineered to withstand the most challenging wet conditions.

Perfect protection against high humidity and environmental conditions, Knauf AQUAPANEL® Exterior Ceiling System is the perfect solution for ceilings exposed to moisture, wind loading and coastal environments. All components are designed and tested to achieve the highest performance of construction.

Knauf AQUAPANEL® Cement Boards are water-resistant and made of inorganic materials, which prevents mildew from forming and spreading.

Our range of coated suspended ceiling structures is available in both a C3 or C5 class of corrosion resistance. This ensures the system is suitable for outdoor areas from urban and industrial atmospheres, with moderate sulphur dioxide pollution to coastal areas with associated salinity.

And finally, the complete system can be specified to withstand any UK based wind load.

## Options for external finishes

External Renders can be specified as a finish coat, offering options for texture and colours.

## Simple installation

Knauf Coated Metal Suspended Frame layout to be created to suit project needs. Contact Knauf Technical for assistance via [technical-uk@knauf.com](mailto:technical-uk@knauf.com)

## Complete Knauf engineered and specified system with one single point of contact

Our team of Project Specification Managers and Area Sales Managers will provide you with support throughout the project; from reviewing the architect's drawings and wind load calculations at the very early stage so that the initial specification can be created, to regular visits on site to ensure optimum system performance.

Working with our team of specialists will guarantee you the highest standards in design, construction, cost-effectiveness and durability.

## Benefits

- Simple installation
- Resistant to moisture and driving rain
- Mildew-resistant
- Stable, robust and durable
- Creative design opportunities
  - Options for the creation of curved ceilings
  - Spectacular ceilings thanks to expansion joints that are only needed every 15m and enable a 225m<sup>2</sup> closed area without a visible joint\*
  - Large choice of colours, textures and finishes using modern thin coat render systems

With Knauf AQUAPANEL® Exterior Ceiling Systems, exterior ceilings are optimally protected against all types of weather effects, regardless of their location.

\*A movement joint must be installed if there is a movement joint in the structure above



For more information see our **Exterior Ceiling System Brochure**

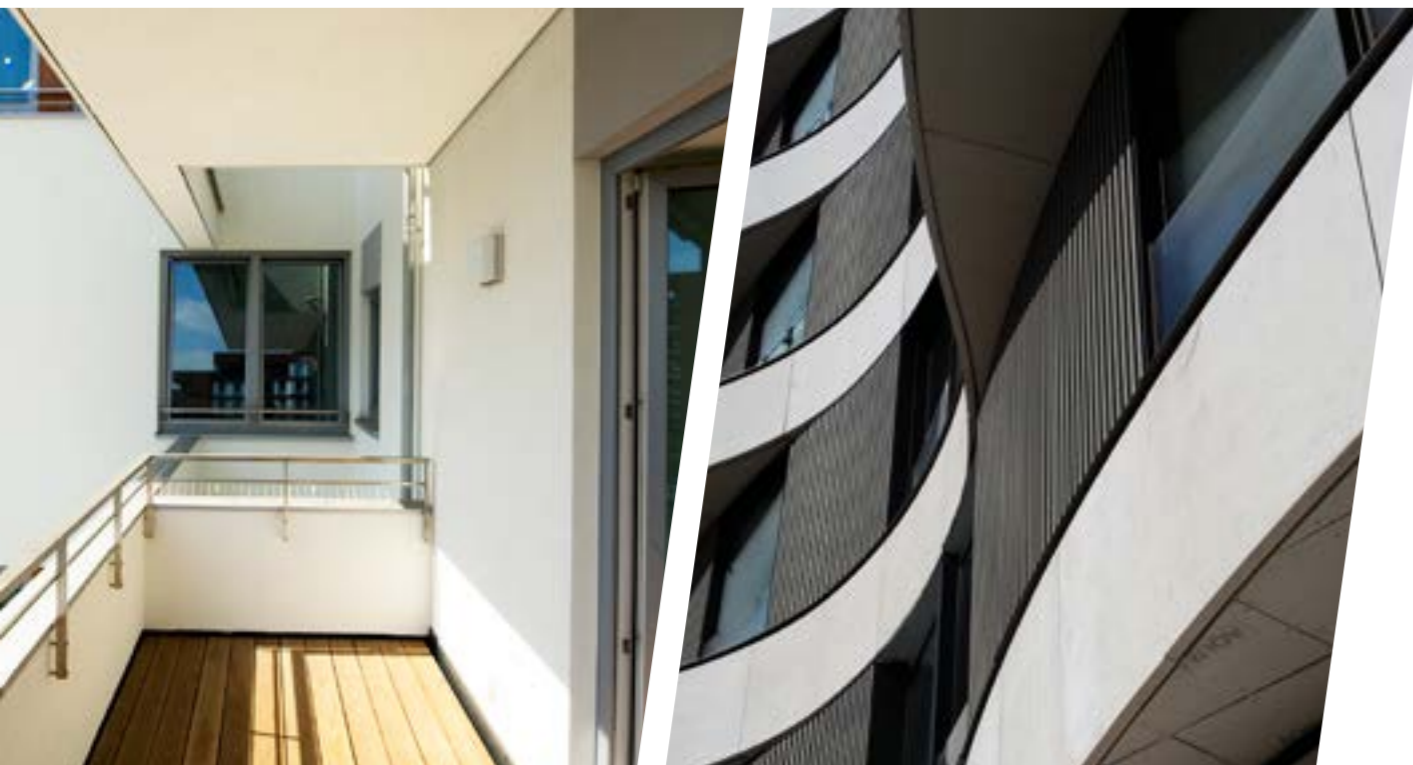

# Knauf Aquapanel® Exterior Ceiling System detail

## Typical Knauf Exterior Soffit Design Detail

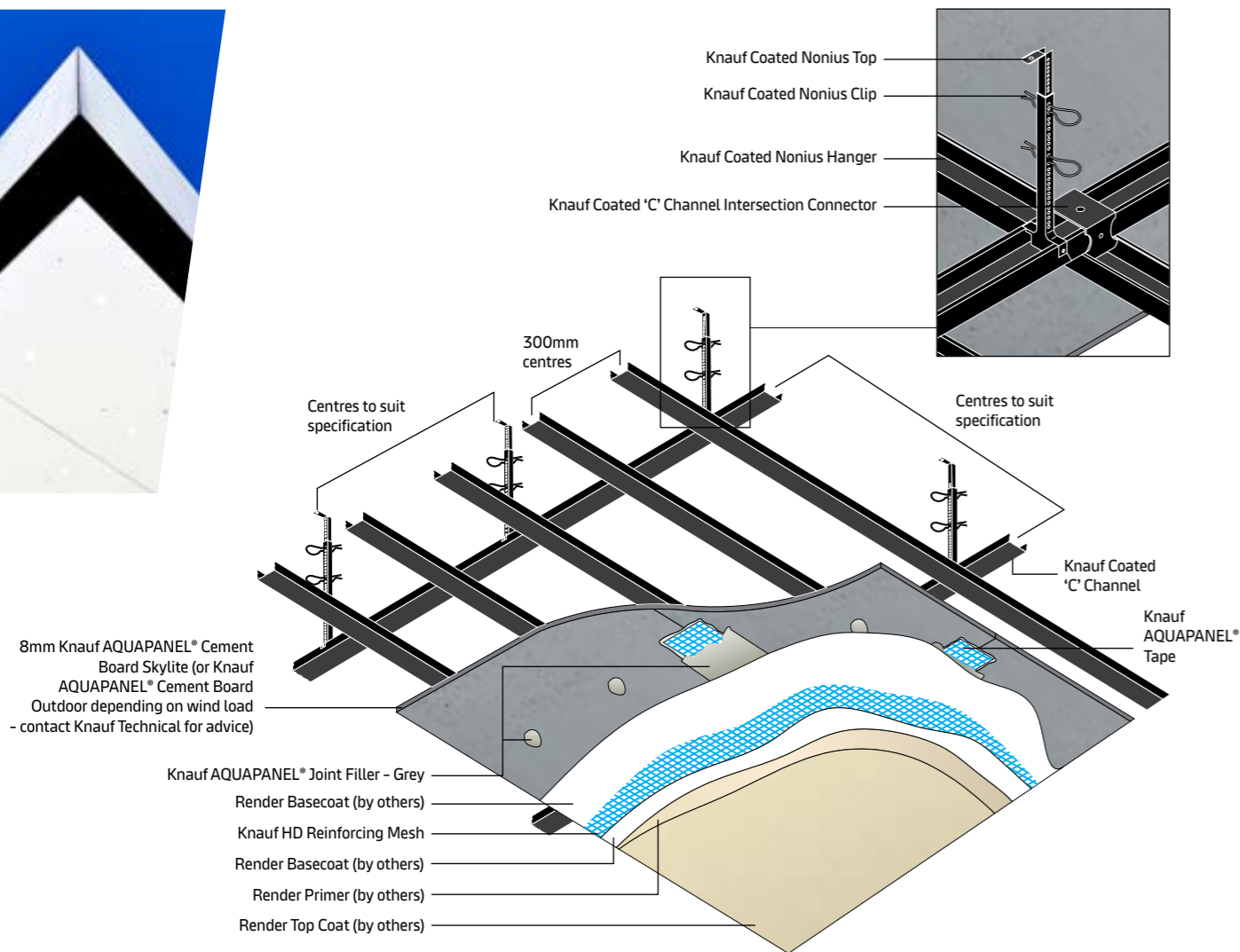

**Note:** Movement joints are required at 15m spans (maximum.) Or to match movement joints in the substrate behind.  
**Further information:** Timber framework can also be used. Contact Knauf for full project specification support.

# AQUAPANEL® Cement Board Outdoor

## Exceptional weatherproofing, outstanding benefits.

Knauf AQUAPANEL® Outdoor is the premium product offering with unrivalled performance in wet and humid conditions, helping to protect buildings quickly, effectively and permanently. Manufactured from aggregated Portland cement, AQUAPANEL® Cement Board Outdoor features coated glass fibre mesh in the back and front surfaces for added strength. The ends are square cut, and the edges reinforced.

### Performance

- 100% water-resistant – dimensional stability
- 100% Non Organic Content
- Mould and mildew resistant
- Freeze and Thaw Tested
- Non-combustible board meeting fire classification of A1 in accordance with EN 13501 Suitable product for use in exterior wall systems
- CE & UKCA approved
- BBA APPROVED
- Jointly BBA certified with other partners
- Fully Compatible and Tested Systems

### Installation

- Lightweight cement board – less effort in handling
- Easy to cut using a simple score and snap technique
- No pre-drilling required
- Bending radius of 3m at full board size, and 1m with 300mm wide strips

### Finishing

The AQUAPANEL® portfolio has the following finishing options: mineral finish, dispersion plaster, and silicon synthetic resin plaster.

However AQUAPANEL® Cement Board Outdoor is also compatible with...

- Thin Coat Render Options
- Brick slips
- Tiles
- Claddings (e.g. natural stone, slip bricks, exterior tiles and many more)

# AQUAPANEL®

## More than just a render carrier

Knauf AQUAPANEL® Cement Board Outdoor, rather than simply being just a render carrier, it provides the basis for a wide range of decorative claddings, such as natural stone, slip bricks and exterior tiles.



### Knauf AQUAPANEL® Cement Board Outdoor Physical properties

Length (mm)	1200 / 2400
Width (mm)	900
Depth (mm)	12.5
Min. bending radius for 900mm wide board	3
Min. bending radius for 300mm wide strip	1
Weight (kg/m <sup>2</sup> )	approx. 16
Dry bulk density (kg/m <sup>3</sup> ) according to EN 12467	approx. 1,150
Bending strength (N/mm <sup>2</sup> ) according to EN 12467	> 7
pH-value	12
Thermal conductivity (W/mK) according to EN ISO 10456	0.35
Thermal expansion (10 <sup>-6</sup> K <sup>-1</sup> )	7
Water vapour diffusion coefficient (-) according to EN ISO 12572	66
Building material class according to EN 13501	A1 non-combustible

ETA Assessed - Certificate number 07-0173  
BBA Assessed - 09/4633

# AQUAPANEL® outdoor Boards and Accessories

## Knauf AQUAPANEL® Cement Board Outdoor

Offers a high quality and economical alternative to traditional methods of construction, such as brick and block. This is a tough cement board for exterior use with a Portland cement and aggregate core and coated glass fibre mesh embedded in the back and front surfaces. Ends are square cut and edges are reinforced and finished smoothly.



Dimensions (mm)			Material No.	Ex Stock	Pallet Details	
Thickness	Width	Length			Boards	Weight (Tonnes)
12.5	900	1200	63117	✓	50	0.87
12.5	900	2400	457318	✓	30	1.01

Compliance: EN 12467. Material Pricing Group: Q1

## Knauf AQUAPANEL® Maxi Screws (SN)

Corrosion protected screws for fixing Knauf AQUAPANEL® to light gauge steel profiles up to 0.7mm. They have a needle point and countersunk heads.



Dimensions (mm)		Material No.	Ex Stock	Pack Details	
Length	Diameter			Items per Carton	kg (Approx.)
25	4.2	87319	✓	1000	1.8
39	4.2	87283	✗	100	0.39
39	4.2	53500	✓	500	2.0
55	4.2	95644	✓	250	2.0

Compliance: EN 14566. Material Pricing Group: Q1

## Knauf AQUAPANEL® Exterior Maxi Screws (SB)

These have been specially developed for fixing Knauf AQUAPANEL® Cement Board Outdoor and Knauf AQUAPANEL® SkyLite onto heavy gauge steel profiles (0.8mm – 2.0mm). They have a drill point and countersunk heads.



Dimensions (mm)		Material No.	Ex Stock	Pack size
Length	Diameter			
25	4.2	94730	✗	250
39	4.2	58549	✗	250

Compliance: EN 14566:2008 + A1:2009. Material Pricing Group: Q1

## Knauf AQUAPANEL® Exterior Stainless Steel Screws (SN)

40mm stainless steel screws specially developed for fixing Knauf AQUAPANEL® Cement Board Outdoor to timber substructures.



Dimensions (mm)		Material No.	Ex Stock	Pack size
Length	Diameter			
40	4	87197	✗	250

Compliance: EN 14566:2008 + A1:2009. Material Pricing Group: Q1

## Knauf AQUAPANEL® Maxi Screws (SN) Collated

Collated 39mm screws. Each pack has 10 belts with 100 screws per belt. Corrosion-protected screws for fixing Knauf AQUAPANEL® to timber frames and light gauge steel profiles (up to 0.7mm) as part of Knauf AQUAPANEL® Interior and Exterior systems. They have a needle point and countersunk heads.



Dimensions (mm)		Material No.	Ex Stock	Pack Details	
Length	Diameter			Items per Carton	kg (Approx.)
39	4.2	87317	✗	1000	3.0

Compliance: EN 14566. Material Pricing Group: Q1

## Knauf AQUAPANEL® Exterior Stainless Steel Screws (SB) Jackpoint

40mm self-drilling stainless steel screws for fixing Knauf AQUAPANEL® Cement Board Outdoor to aluminium substructures.



Dimensions (mm)		Material No.	Ex Stock	Pack size	Inc. Carriage
Length	Diameter				
40	4	424110	✗	250	✓

Compliance: EN 14566:2008 + A1:2009. Material Pricing Group: Q1

## Knauf AQUAPANEL® Joint Filler – Grey

This is a cement-based material for filling joints and embedding Knauf AQUAPANEL® Tape and Knauf AQUAPANEL® Reinforcing Mesh as part of the Knauf AQUAPANEL® Exterior and Interior Ceiling systems.



Bag Size	Material No.	Ex Stock	Pallet Qty
Length			
20	131094	✓	48

Compliance: EN 998. Shelf Life: 12 Months. Estimated Coverage: 28m²/bag. Material Pricing Group: Q1. Available in part pallet quantities.

## Knauf AQUAPANEL® Tape

Knauf AQUAPANEL® Tape is a 100mm wide, glass fibre tape with an alkaline-resistant coating. It is embedded into Knauf AQUAPANEL® Joint Filler – Grey, AQUAPANEL® Joint Filler and Skim Coat – White, or tile adhesive, to reinforce joints as part of a Knauf AQUAPANEL® Exterior or Interior system.

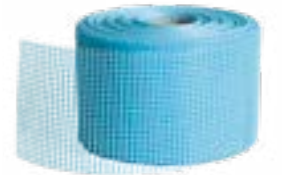

Dimensions		Material No.	Ex Stock	Pack size
Length (m)	Width (mm)			
50	100	429471	✓	12
20	100	465546	✓	18

Estimated Coverage: 2.1m²/m². Material Pricing Group: Q1

## Knauf AQUAPANEL® Exterior Reinforcing Tape

This tape is a 200mm wide meshed glass fabric. It is embedded in Knauf AQUAPANEL® Joint Filler – Grey to reinforce exterior joints where paint or alternative finishes are to be applied.



Dimensions		Material No.	Ex Stock	Carton Details	
Length (m)	Width (mm)			Rolls per Carton	kg (Approx.)
50	200	424086	✗	12	10

Estimated Coverage: 2.1m²/m². Material Pricing Group: Q1 Available in part pallet quantities.

## Knauf AQUAPANEL® Water Barrier

This is a water resistant and wind tight membrane which provides superior air and moisture management. It is used as a water conducting layer directly behind Knauf AQUAPANEL® Cement Board Outdoor where it prevents water, which finds a way behind the board, from ingressing into the wall.



Dimensions (m)		Material No.	Ex Stock	Pallet Qty
Length	Width			
50	1.5	544043	✗	50

Compliance: EN 13859-2:2014. Material Pricing Group: Q1

# Need more information on Knauf AQUAPANEL® range?

Discover a world of online resources and support available 24/7 to help you understand and communicate the full scope of the AQUAPANEL® family. Find and download in-depth technical documents, films and the latest materials, always up to date.

## See AQUAPANEL® in action

Our YouTube channel features product introductions and how-to videos on everything from installation to finishing options and curved wall constructions. It's all available any time – and we'll be regularly updating the channel with our latest videos, making it the first place to go for new AQUAPANEL® content.

### For more information visit:

- [knauf.co.uk/systems-and-products](https://knauf.co.uk/systems-and-products)
- [Knauf.co.uk](https://knauf.co.uk)
- Live Webchat 09:00 - 17:00 available at [knauf.co.uk](https://knauf.co.uk)
- Search for **Knauf AQUAPANEL®** channel on YouTube



## CITB Accredited Training Organisation



The Learning Zones at Immingham and Sittingbourne are CITB approved training facilities and offer various courses for the construction industry. We believe in future-proofing and protecting the workforce.

We provide the best possible training on the large variety of systems and products that we supply, and make our courses widely available to those who request them. Whether the trainees are already skilled tradespeople, wishing to add to their existing knowledge, or people with no previous experience, there is a course in our range to benefit all.

We are happy to advise on the suitability of different courses and the content can be adapted to suit the requirements of the delegates.

All work carried out on the Knauf courses will be in a simulated site environment, and to industry standards, using British Standard and European Codes of Practice for accuracy and finish.

Contact us to find out more about the latest courses available.

## Courses available

[Drylining – Direct bonding and metal lining systems](#)

[Fire protection – Encasement systems](#)

[General overview of interior products and systems](#)

[Metal stud partitions, shaft wall, wall linings](#)

[Metal suspended ceiling systems](#)

[Flooring – Brio and GIFA systems](#)

[Façades – Steel framing systems](#)

[Taping and jointing](#)

[AQUAPANEL® Indoor and Outdoor](#)

[Passive fire protection](#)

[Demountable ceiling systems](#)

[Drywall for site managers / Quality Control](#)

[Airless spray finishing](#)

Telephone: **01795 424499**  
 Email: [technical-uk@knauf.com](mailto:technical-uk@knauf.com)  
 Website: [knauf.co.uk](https://knauf.co.uk)



# Look to the future – Build on us

**We recognise the importance of the buildings in which we all live, work and relax.**

We spend 90% of our lives inside buildings, so it is of the utmost importance that the homes we live in, the hospitals where we care for our sick, the schools in which we educate our children and the offices in which business operates are world class, safe, comfortable, sustainable and enjoyable.

The extensive portfolio of products and systems from Knauf UK & Ireland is developed to support that vision.

As a business, we look to the future; building on the knowledge we have acquired with a planned programme of research and development to make sure we continue to keep ahead of current thinking.

Looking to the future also means that our business must be sustainable. We are always conscious of the wider consequences of our actions, both today and tomorrow.

In terms of our operation we work hard to minimise our impact on the environment and are proud of our recycling, waste reduction and energy efficiency initiatives.



Healthcare



Education



Residential

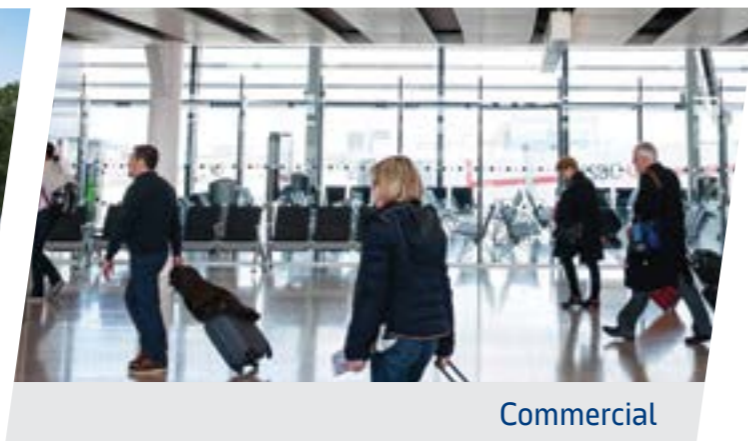

Commercial

## AQUAPANEL® Complete system solutions

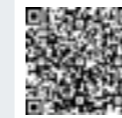

Knauf AQUAPANEL®  
Exterior Ceiling System  
Brochure

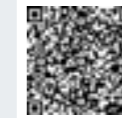

Knauf AQUAPANEL®  
Interior Ceiling System  
Brochure



Knauf AQUAPANEL®  
Cement Board Indoor  
Brochure



### Customer Service

UK Tel: 0800 521 050  
Eire Tel: 01 4620739  
Email: [cservice@knauf.co.uk](mailto:cservice@knauf.co.uk)

### Technical Service

Live Webchat 09:00 -17:00  
[technical-uk@knauf.com](mailto:technical-uk@knauf.com)  
(excluding Public Holidays)

### Literature

UK Tel: 03700 613 700  
Eire Tel: +44 3700 613 700

### Social Media

 KnaufUK  
 KnaufUK  
 Knauf UK & Ireland  
 @Knauf\_UK

### Addresses

Knauf  
Kemsley Fields Business Park  
Sittingbourne  
Kent ME9 8SR

Knauf  
87 Broomhill Road  
Tallaght  
Dublin 24  
D24 WR85

**Website**  
[knauf.co.uk](http://knauf.co.uk)  
[knauf.ie](http://knauf.ie)



This document is printed  
on 80% recycled paper



When you have finished with  
this document please recycle it