

KNAUF

كناوف



Technical Datasheet

05-2018

Knauf Furring Channel Clips

The Knauf furring channel clip is designed to secure the Knauf furring channels to the main 'C' carrying channel. The furring channel clip is placed over the main 'C' carrying channel then clipped to the underside flanges of the furring channel; this is done to both sides of the furring channel.

Knauf Furring Clips

Product Description

The Knauf furring channel clip is designed to secure the Knauf furring channels to the main 'C' carrying channel. The furring channel clip is placed over the main 'C' carrying channel then clipped to the underside flanges of the furring channel; this is done to both sides of the furring channel.

Technical Data

Knauf Furring Clip

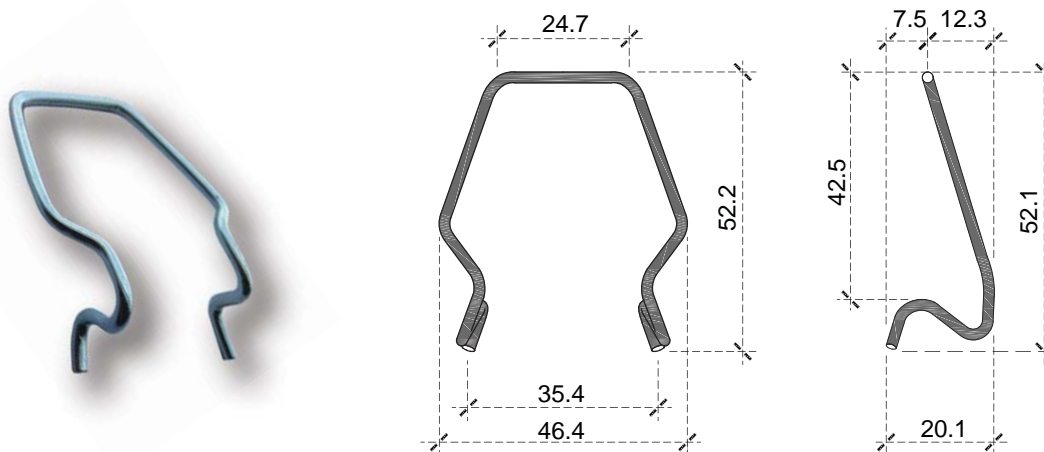

Note:

Please contact our sales department for inquiries about storage and packing.

Knauf Head Office

- ▶ Phone: +971 4 337 7170
- ▶ Fax: +971 4 334 9659
- ▶ P.O. Box: 112871, Dubai
- ▶ info@knauf.ae

Knauf Qatar Office

P.O.Box 27111
Doha, State of Qatar
Tel: +974 44528191
Fax: +974 44528181

Knauf Manufacturing Plant

P.O.Box 50006
Ras Al Khaimah, U.A.E.
Tel: +971 7 221 5300
Fax: +971 7 221 5301



The information provided in this leaflet is only intended to give guidance in selecting and using Knauf products. While we make every effort to ensure its accuracy, neither Knauf LLC and its branches nor any of this employees or affiliates warrant or assume any legal liability or responsibility for the completeness or usefulness of any failure in installation or constructing structure installation or building or caused by using this leaflet. Readers are advised to independently verify this information prior to reply on it. In particular, readers must obtain appropriate independent advice on the use of products in specific structures, installations or buildings to ensure compliance with all regulations, including health and safety regulations. Knauf reserves the right to amend technical specification without notice.