

KNAUF

PLASTERBOARD INSTALLATION MANUAL



Build on us.

Content

1 GENERAL INFORMATION

| | |
|------------------------------------|----|
| Introduction | 4 |
| References | 5 |
| Plasterboard Types | 6 |
| Plasterboard Features and Benefits | 7 |
| Plasterboard Properties | 8 |
| Sustainability | 10 |
| Safety | 10 |
| First Aid | 10 |

2 DESIGN CONSIDERATIONS

| | |
|-----------------------------|----|
| Condensation | 11 |
| Ventilation | 11 |
| Devices Generating Heat | 12 |
| Acoustics | 12 |
| Attachments | 13 |
| Walls on Boundary | 13 |
| Attached Dwellings Class 1A | 13 |
| Control Joints | 13 |
| Levels of Finish | 14 |
| Glancing Light | 16 |

3 WORKING WITH PLASTERBOARD

| | |
|--------------------------------|----|
| Plasterboard Sizes | 17 |
| Material Quantities | 18 |
| Delivery, Handling and Storage | 19 |
| Framing Check | 20 |
| Fixing Face Requirements | 20 |
| Timber Framing | 20 |
| Steel Framing | 21 |
| Linings Layout | 21 |
| Fastening Systems | 22 |
| General Screw and Nail Fixing | 22 |
| Plasterboard Fasteners | 22 |

4 INTERNAL CEILINGS

| | |
|------------------------------------|----|
| Ceiling Loads and Spans | 23 |
| Ceiling Support Options | 24 |
| Metal Furring Channels and Battens | 25 |
| Control Joints | 26 |
| Fixing to Ceilings | 26 |

All works undertaken to prescribe the use of or to install Knauf's products and systems must be performed by experienced and, where required by applicable laws, appropriately licensed personnel. Knauf's products and systems must be installed in accordance with Knauf's installation manual, Systems+, and any other product or system specific literature issued by Knauf. If installation works are not performed in compliance with such product literature, by experienced and licensed personnel, or are incorrectly performed by experienced or licensed personnel, there is a serious risk that the works, application and performance of the relevant system or products will be compromised, which could result in property damage, injury or death.

All personnel who undertake works to install Knauf's products and systems must comply with all applicable health and safety laws, including wearing appropriate personal protection equipment. If personnel do not comply with applicable health and safety laws, including by not wearing appropriate personal protection equipment, there is a serious risk of injury or death.

All of Knauf's products and systems must only be used for the uses identified in this document (and any other product or system specific literature issued by Knauf from time to time). Before prescribing or using any Knauf product or system for any other use, you must contact Knauf. All recommended component parts for Knauf's products and systems should be used and not substituted for other products. If component parts are substituted, there is a serious risk that the works, application and performance of the relevant system or products will be compromised, which could result in property damage, injury or death.

This product manual is intended to provide general information on plasterboard products and should not be used as a substitute for professional building advice. We recommend you use a qualified person to install Knauf plasterboard. To ensure the information you are using is current, Knauf recommends you review the latest building information available on the Knauf website Knauf.com. For further information contact TecASSIST or your Knauf representative.

5 GARAGE AND EXTERNAL CEILINGS

| | |
|-----------------------------------|----|
| General | 30 |
| Design Notes | 30 |
| Installation of Garage Ceilings | 31 |
| Installation of External Ceilings | 32 |

6 FRAMED WALLS

| | |
|---|----|
| Fixing with Combination of Adhesive and Fasteners | 34 |
| Fixing with Screws Only | 34 |
| Fixing with Nails Only | 35 |
| Butt Joints in Walls | 35 |
| Internal Corners | 36 |
| Control Joint Installation | 37 |
| Door Jambs | 38 |
| Shadowline Stopping Angle | 38 |
| Wall-Ceiling Junctions | 39 |

7 MASONRY WALLS

| | |
|--|----|
| General | 40 |
| Installation Using Masonry Adhesive Method | 40 |
| Installation Using Battens /Furring Channels | 42 |

8 WET AREAS

| | |
|-------------------------|----|
| Regulatory Requirements | 43 |
| Knauf Wet Area System | 45 |

9 CURVES AND ARCHES

| | |
|--|----|
| Constructing Curved Walls and Ceilings | 52 |
| Arches | 52 |

10 CORNICES

| | |
|-------------------------|----|
| Knauf Cornices | 54 |
| Handling and Layout | 55 |
| Cutting Cornice | 55 |
| Fixing Cornice | 56 |
| Mixing Cornice Adhesive | 56 |

11 JOINTING

| | |
|--------------------------------|----|
| General | 57 |
| Jointing Compounds | 57 |
| Jointing Tapes | 61 |
| Tools and Accessories | 61 |
| Jointing with Hand Tools | 61 |
| Jointing with Mechanical Tools | 66 |

12 DECORATING PLASTERBOARD LININGS

| | |
|---------------------------------|----|
| General Requirements | 68 |
| Surface Preparation | 68 |
| Painting | 68 |
| Avoiding Glancing Light Effects | 68 |



PLASTERBOARD

Introduction

This manual is intended for use by plastering contractors and builders. It outlines recommended methods for installation, jointing and finishing of Knauf plasterboard linings in non-fire rated residential construction including general areas, wet areas, garage ceilings and shielded external ceilings in non-cyclonic regions.

Refer to Knauf Systems+ and relevant system publications for fire-rated and acoustic construction details.

While this manual outlines plasterboard installation specifications for timber-framed construction, similar installation, jointing and finishing details apply to steel-framed buildings. Refer to relevant Knauf publications for steel-framed plasterboard construction details.

Installation specifications outlined in this manual apply to Level 4 finish, unless noted otherwise (see Levels of Finish).

GENERAL INFORMATION

References

The following Australian and other Standards are referenced in this publication:











- AS/NZS 2588 Gypsum plasterboard
- AS/NZS 2589 Gypsum linings – Application and finishing
- AS 3740 Waterproofing of domestic wet areas
- AS/NZS 4858 Wet area membranes
- AS 1684 Residential timber framed construction
- AS 4440 Installation of nail plated timber roof trusses
- AS/NZS 1170.2 Wind actions
- AS 2753 Adhesive – For bonding gypsum plaster linings to wood and metal framing
- AS 1397 Steel sheet and strip – hot dipped, zinc coated or aluminium/zinc coated
- AS 3700 Masonry structures
- AS/NZS 2918 Domestic solid-fuel burning appliances – Installation
- AS/NZS 5601.1 Gas installations
- National Association of steel-framed housing (NASH) standard for residential and low-rise steel framing
- AS 3566.1 Self-drilling screws for the building and construction industries
- AS 1145.3 Determination of tensile properties of plastic materials. Part 3: Test conditions for films and sheets
- AS/NZS 1716 Respiratory protective devices
- ISO 9002 Quality systems – Model for quality assurance in production, installation and servicing
- AS/NZS 2311 The painting of buildings
- AS/NZS 4600 Cold-formed steel structures.

GENERAL INFORMATION CONT.

Plasterboard Types

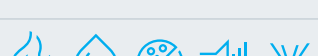
Knauf offers a wide range of plasterboard products to suit various applications:

Table 1: Knauf Plasterboard Types

| Plasterboard Type | Thickness (mm) | Mass (kg/m ²) | Attributes (refer key) | Application |
|----------------------|----------------|---------------------------|--|---|
| SHEETROCK ONE | 10 | 5.9 |  | Residential wall and ceiling linings |
| | 13 | 8.5 |  | Residential/Commercial wall and ceiling linings |
| SHEETROCK PLUS | 10 | 8.5 |  | Residential wet area, external and garage ceiling, acoustic wall and ceiling and impact resistant linings |
| WetStop | 13 | 9.2 |  | Wet area, external and garage ceiling linings |
| FireStop | 13 | 10.9 |  | Fire resistant wall and ceiling linings |
| | 16 | 13.4 | | |
| ImpactStop | 13 | 12.0 |  | High impact, sound and fire resistant linings |
| MultiStop ONE | 13 | 12.0 |  | High impact, fire, sound, water and mould resistant linings |
| | 16 | 14.6 | | |
| MultiStop ONE HI | 13 | 12.0 |  | Very high impact with mesh reinforcement, sound, fire, water and mould resistant linings |
| FIBEROCK Aqua-Tough | 13 | 11.7 |  | Ultimate impact, water, sound, fire and mould resistant linings |
| | 16 | 15.1 | | |
| Shaftliner MouldStop | 25 | 20.5 |  | Shaft enclosure and separating wall linings |
| Flexiboard | 6.5 | 4.1 |  | Curved walls and ceiling linings |
| Gib X-Block* | 13 | 17.2 |  | X-ray radiation protection linings |
| EchoStop | 12.5 | 10.0 |  | Sound absorption within a room linings |
| Stratopanel | 12.5 | 7.4 - 8.6 |  | Sound absorption within a room linings |

* Gib X-Block is not manufactured by Knauf Group.

Key



Fire Resistant



Lightweight



Impact Resistant



Mesh Reinforced



Water Resistant



Acoustic Performance



High Impact Resistant



Flexible



Mould Resistant



Echo Reduction



Very High Impact Resistant



Block Basic Radiation



Ultimate Impact Resistant

Notes

Product availability should be checked with Knauf as some products may only be available on order and/or in minimum order quantities.

GENERAL INFORMATION CONT.

Figure 1: Knauf Plasterboard Types

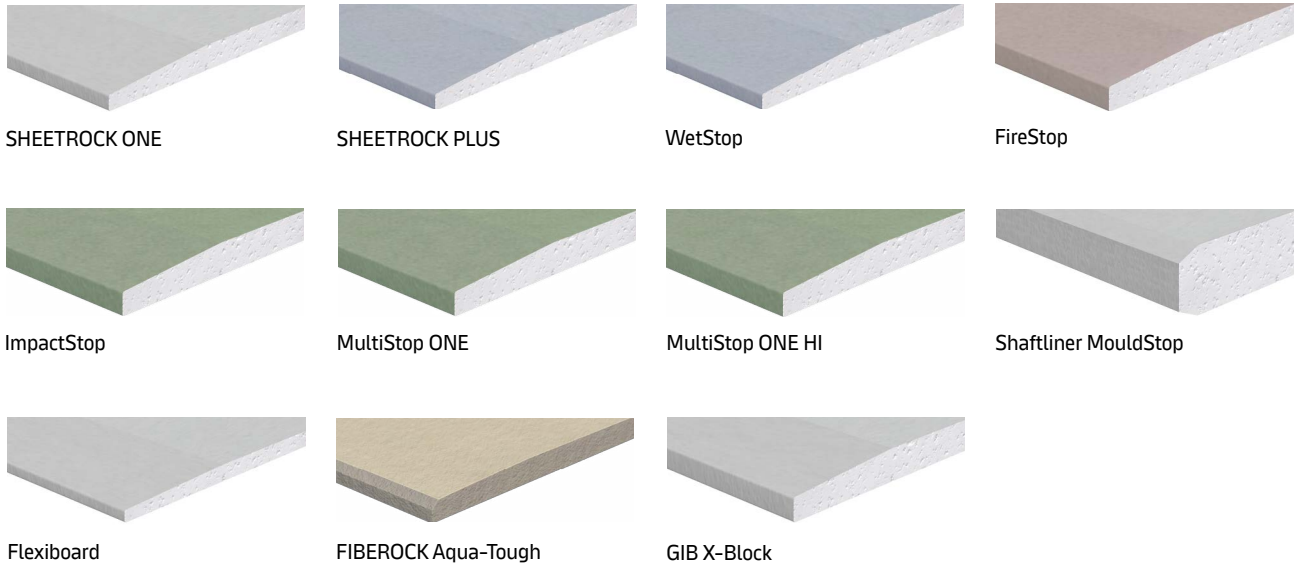

Plasterboard Features and Benefits

Developed by USG (now part of the Knauf Group) more than 100 years ago, gypsum board is commonly used by building professionals as a dry lining material for internal walls and ceilings in modern commercial and residential construction.

SHEETROCK Technology developed by USG has resulted in a lighter and more robust product than standard plasterboard.

Plasterboard benefits include:

- Lightweight
- Cost effective
- Versatile
- Easy to install to timber, steel and masonry substrates
- Provides smooth, stable base for paint and other decorative finishes
- Contains recycled materials.

Plasterboard sheets are commonly available in 1200 mm and 1350 mm widths and have recessed longitudinal edges facilitating a smooth, seamless joint finish.

Knauf Plasterboard products meet the requirements of AS/NZS 2588 Gypsum plasterboard.

Plasterboard Properties

Dimensional Stability

Under normal ambient temperature and humidity conditions, plasterboard has the following expansion properties:

Thermal Coefficient of Linear Expansion:

$16.2 \times 10^{-6} \text{ mm} / (\text{mm}^\circ\text{C})$ at temperature range 4 to 38°C.

Hygrometric Coefficient of Linear Expansion:

$7.2 \times 10^{-6} \text{ mm} / (\text{mm}\% \text{ RH})$ over the range of 5% to 90% relative humidity.

Thermal Resistance

The R-values of some Knauf products are provided in the following table:

Table 2: Thermal Resistance

| Plasterboard Type | R-value |
|---------------------------|-------------------------------|
| 10 mm SHEETROCK ONE | 0.056 m ² K/W ±10% |
| 13 mm SHEETROCK ONE | 0.073 m ² K/W ±10% |
| 13 mm FIBEROCK Aqua-Tough | 0.049 m ² K/W ±10% |

GENERAL INFORMATION CONT.

Plasterboard Properties Continued

Fire Resistance

Plasterboard is deemed to be a non-combustible material for the purposes of the National Construction Code (NCC) in accordance with Deemed-to-Satisfy Provision C2D10 of NCC 2022 Volume, and Section 9 of ABCB Housing Provision NCC 2022.

While plasterboard inherently possesses a certain degree of fire resistance due to the chemical composition of the gypsum core, the following Knauf products have enhanced fire resistance properties and are specifically formulated for use in fire-rated construction:

- FireStop
- ImpactStop
- MultiStop ONE
- MultiStop ONE HI
- FIBEROCK Aqua-Tough
- Shaftliner MouldStop.

Notes

FIBEROCK Aqua-Tough is deemed non-combustible when tested in accordance with AS 1530.1-2024.

Fire Hazard Properties

Wall and ceiling lining materials in certain types of buildings must comply with the Fire Hazard Properties requirements of the NCC.

All Knauf plasterboard lining products are classified as Group 1 (least hazardous) materials and have a smoke growth rate index less than 100 and/or an average specific extinction area less than 250 m²/kg when tested in accordance with the NCC.

Impact Resistance

Knauf offers a number of lining products specifically developed for applications requiring enhanced impact resistance:

Table 3: Impact Resistant Lining Products

| Product | Impact Resistance Levels |
|---------------------------|--------------------------|
| SHEETROCK PLUS | Impact |
| ImpactStop, MultiStop ONE | High Impact |
| MultiStop ONE HI | Very High Impact |
| FIBEROCK Aqua-Tough | Ultimate Impact |

Water Resistance

Although plasterboard is not a waterproof material, Knauf offers a number of lining products classified as water resistant under the NCC requirements for domestic wet areas. These products include:

- SHEETROCK PLUS
- WetStop
- MultiStop ONE
- MultiStop ONE HI
- Shaftliner MouldStop
- FIBEROCK Aqua-Tough.

GENERAL INFORMATION CONT.

Sustainability

Knauf plasterboards are manufactured from a combination of natural gypsum, and paper liner made from 100% reclaimed and recycled paper waste. Plasterboard waste can be reclaimed and recycled into new plasterboard or reused as soil conditioner.

Knauf Australian manufactured plasterboards are listed with Product Aware and have GECA, Climate Opt-In certification and independently verified EPD that may contribute to Green Star credit points. For more information refer to Green Building Council of Australia.

Raw Materials

Gypsum used in locally manufactured Knauf plasterboard products is mined from abundant resources at Kevin in South Australia. The mine has in place a rehabilitation and revegetation strategy aimed at creating a landscape with natural appearance and native local vegetation.

Plasterboard paper liner is manufactured from reclaimed and recycled paper waste. FIBEROCK Aqua-Tough contains 95% recycled content.

Quality Assurance

All Knauf Australia plasterboard production facilities are certified under ISO 9002 Quality systems – Model for quality assurance in production, installation and servicing.

Plasterboard Manufacture

Apart from natural gypsum and recycled paper, the key inputs in the plasterboard manufacturing process are natural gas and potable water.

Knauf aims at exceeding the local Environment Protection requirements and at maximising the use of recycled water at its manufacturing facilities

Embodied Energy

As shown in the following table, embodied energy per kg of plasterboard compares favourably with other lining materials:

Table 5: Embodied Energy of Lining Materials

| Material | PER* Embodied Energy (MJ/kg) |
|---------------|------------------------------|
| Plasterboard | 4.4 |
| Fibre cement | 4.8 |
| Particleboard | 8.0 |
| Plywood | 10.4 |
| MDF | 11.3 |
| Hardboard | 24.2 |

* PER – Process Energy Requirements.
Source: Building Materials Energy and the Environment, Bill Lawson, The Royal Australian Institute of Architects, 1996.

Table 4: Knauf Plasterboards and FIBEROCK Aqua-Tough Sustainability Certifications Overview

| Plasterboards | Sustainability Certifications |
|---|---|
| SHEETROCK ONE, SHEETROCK PLUS, WetStop, FireStop, ImpactStop, MultiStop ONE, MultiStop ONE HI, Shaftliner MouldStop |     |
| FIBEROCK Aqua-Tough |   |

GENERAL INFORMATION *CONT.*

Safety

The following precautions are recommended when installing and finishing plasterboard:

- Avoid creating dust when handling plasterboard or mixing jointing compounds
- When sanding, minimise the effects of dust by:
 - Providing adequate ventilation
 - Wearing eye protection
 - Wearing a respiratory mask conforming to AS/NZS 1716 Respiratory protective devices
 - Using mechanical sanding tools fitted with dust extractor and storage bag.
- Keep tools and materials out of reach of children.

In addition, the users should observe Occupational Health and Safety tips contained on the packaging labels for Knauf products as well as safe manual handling practices.

First Aid

- If plaster compound or dust comes into contact with the eyes, wash eyes thoroughly with clean potable water
- If plaster compound or dust comes into contact with skin, wash skin thoroughly with soap and water
- If dust is inhaled, move to a fresh air environment
- If plastering compound or dust is ingested, drink plenty of water

Material Safety Data Sheets for Knauf products can be downloaded from **knauf.com**.

In emergencies call 1800 033 111.
For poison assistance call 13 11 26.

DESIGN CONSIDERATIONS

When designing a house, a number of factors need to be considered to ensure satisfactory internal environment and long term performance of plasterboard linings:

Condensation

Condensation occurs when warm and humid air comes into contact with cold surfaces.

Condensation on internal building surfaces is more likely to occur where there are large temperature fluctuations and the moisture content inside a house (often generated in a bathroom, laundry or kitchen) is high.

Repeat or prolonged condensation may lead to: nail-popping, sagging ceiling linings, rotting, mould growth, joint and corner cracking, and deterioration of internal air quality. If left untreated, condensation may result in structural damage to the building and health concerns for the building occupants.

The following precautions can help minimise internal condensation:

- Keep air spaces well ventilated to promote moisture dissipation, especially in the roof and sub-floor spaces
- In rooms such as bathrooms, kitchens and laundries, exhaust moisture-laden air to the outside of the building and not into the roof or ceiling space
- Use vapour barriers in conjunction with insulation around the building envelope. Place vapour barrier on the warm side of insulation
- Use thermal breaks on steel framing members (refer NCC).

Roof Sarking

Roof sarking can reduce the risk of condensation and also provides protection from the elements such as wind, dust and rain.

Sarking is strongly recommended, even where not required by the NCC, under tiled roofs in order to prevent ceiling damage due to rain blowback.

Ventilation

Roof spaces and building sub-floors should be well ventilated in order to prevent condensation and heat build up (especially in metal framed buildings and dark coloured roofs without sarking).

Refer NCC for minimum ventilation and clearance requirements for sub-floor spaces.

Ample air space is necessary for good ventilation in ceiling areas, particularly below metal decks and tiled roofs with aluminium foil sarking.

Knauf recommends ventilating unheated roof spaces above ceilings in cold or moderate climates by:

- Using louvres or other ventilation devices (i.e. Whirlybirds) to cross-ventilate roof spaces

- Ensuring any attic space suitable for use as a habitable room, or walled-off storage area has at least 50% of the required ventilating area located in the upper part of the ventilated space
- Restricting the unheated space to as near the high point of the roof as possible and above the anticipated level of any future ceilings
- Ensuring that the ratio of the total net free ventilating area to ceiling area is not less than 1:150.

Figure 2: House Ventilation Paths

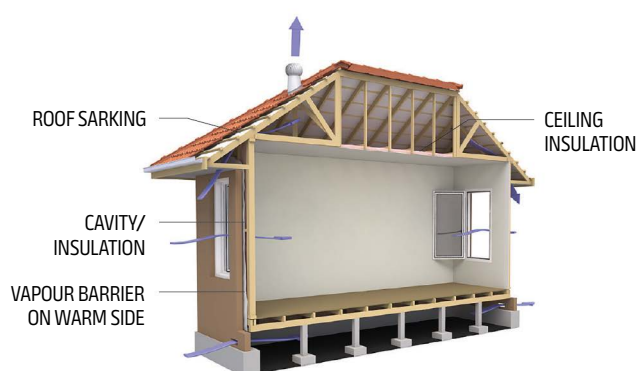

Devices Generating Heat

Knauf plasterboard does not recommend the use of radiant heating systems continuously subjecting plasterboard walls and ceilings to temperatures in excess of 52°C.

Prolonged exposure to temperatures higher than 52°C may cause changes in the chemical composition of the gypsum core and a loss of plasterboard integrity over time.

The following regulatory and normative requirements must be followed in order to prevent plasterboard deterioration due to excessive temperatures from heat generating devices:

- NCC provisions for installation of heating appliances, fireplaces, chimneys and flues
- AS/NZS 2918 Domestic solid-fuel burning appliances – Installation
- AS/NZS 5601.1 Gas installations.

In accordance with AS/NZS 5601.1, gypsum based wall boards within 200 mm of the edge of the nearest burner must be protected to a height of not less than 150 mm above the periphery of that burner and for the full length of the cooking surface area.

DESIGN CONSIDERATIONS CONT.

Based on the requirements of AS/NZS 5601.1, the following backing materials can be used behind various types of splashbacks in domestic and commercial applications:

Domestic Applications

Allowable backing materials in domestic applications are outlined in Table 5:

Table 6: Allowable Splashback Backing Materials in Domestic Applications

| Splashback Type | Minimum Backing Material |
|--|---|
| Min 5 mm ceramic tile | Single layer of minimum 10 mm non-fire resistant plasterboard |
| Min 5 mm toughened safety glass (to AS/NZS 2208) | Single layer of minimum 10 mm non-fire resistant plasterboard |
| Min 0.4 mm sheet metal | Single layer of minimum 10 mm non-fire resistant plasterboard + single layer of minimum 6 mm fibre cement |
| | Single layer of 13 mm or 16 mm FIBEROCK Aqua-Tough |

Notes Non-fire resistant plasterboards include SHEETROCK ONE, SHEETROCK HD, SoundStop and WetStop.

FIBEROCK Aqua-Tough in Domestic and Commercial Applications

In accordance with AS/NZS 5601.1, 13 mm and 16 mm FIBEROCK Aqua-Tough are non-combustible, paperless products suitable for use behind splashbacks or at a minimum distance of 150 mm from gas burners in domestic cooking appliances. A single layer of 13 mm or 16 mm FIBEROCK Aqua-Tough can also be used in commercial kitchens adjacent to non-commercial catering appliances. However, FIBEROCK Aqua-Tough is not suitable for use adjacent to commercial catering appliances.

Notes

- Paper-faced plasterboard ie FireStop or MultiStop ONE cannot be used behind splashbacks in commercial kitchens.
- Knauf does not advise the use of plasterboard as a wall lining behind and around fireplaces unless protected in accordance with the NCC.

Acoustics

Effective sound isolation is an essential element of functional house design.

Unwanted noise may emanate from external sources such as traffic or neighbouring properties, or from internal sources such as home entertainment systems or plumbing.

Common design factors that can influence the level of noise within a house include:

- House orientation
- Internal layout
- Location of doors and windows
- Placement of power points, downlights and other services penetrations
- Placement of plumbing and heating/air conditioning services
- Location of appliances and audio visual equipment.

The NCC stipulates minimum acoustic insulation requirements for separating walls and floors in multi-residential buildings. These include minimum acoustic ratings (R_w and $R_w + C_{tr}$) and acoustic impact insulation requirements. Refer to Knauf Systems+ for a summary of NCC acoustic requirements and systems that satisfy these.

Figure 3: Noise Levels

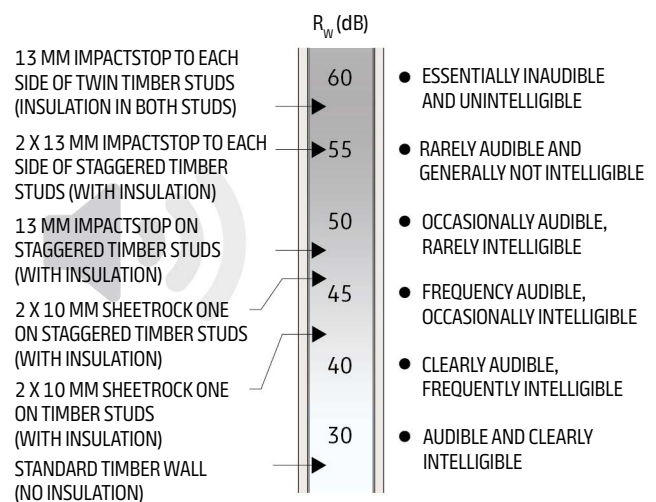

Notes Acoustic performance of timber or steel framed wall systems can be improved by adding cavity insulation.

DESIGN CONSIDERATIONS CONT.

Attachments

A wide range of proprietary fixings are available for attaching light fixtures directly to plasterboard linings. Such fixings should be used in accordance with manufacturers' instructions and should not support loads in excess of maximum allowed.

Heavy loads must be fixed directly into the studs or noggings with appropriate fasteners.

The following point loads can be supported directly by Fiberock linings:

Table 7: Maximum Loads on Fiberock

| FIBEROCK Aqua-Tough Thickness | Maximum Point Load Parallel to the Board* |
|-------------------------------|---|
| 13 | 13 kg |
| 16 | 16 kg |

* Loads applied at the head of a single 8 gauge high thread screw inserted sufficiently to allow the parallel thread section of the screw to be in contact with the full depth of the FIBEROCK lining.

Notes

Wall framing must be checked for its capacity to carry attached loads. Refer to Knauf for attachments to fire-rated systems.

Walls on Boundary

According to NCC, external walls on or in close proximity to the boundary are required to be fire-rated (refer NCC for fire rating requirements). Knauf OutRwall lightweight external wall systems have been specifically designed for this application and are available in fire ratings up to FRL 90/90/90.

Figure 4: OutRwall System OWT60.1 (FRL 60/60/60 from outside only)

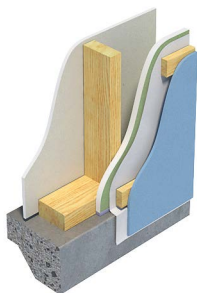

Attached Dwellings Class 1A

Separating walls between attached dwellings must satisfy NCC fire rating and acoustic requirements.

Knauf Partiwall lightweight separating wall systems (timber or steel) have been specifically designed to suit Australian construction methods and are available in fire ratings up to FRL 90/90/90 from both sides and acoustic ratings up to R_w 70 and $R_w + C_{tr}$ 61.

Figure 5: Partiwall System PWT60.1 (FRL 60/60/60)

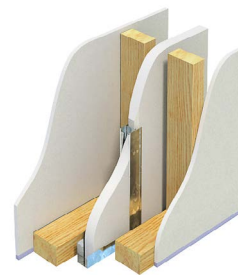

Control Joints

Plasterboard linings are not designed to withstand stresses due to structural movements or excessive changes in temperature or humidity.

Potential stress build up and cracking can be minimised by incorporating control joints as follows:

- Provide control joints in walls and ceilings at maximum 12 m intervals in both directions (max 6 m intervals in external ceilings) and at every change of lining material type (i.e. gypsum board to fibre cement)
- In tiled areas, control joints in walls to be 3.0-4.5 m max centres in accordance with AS 3958.1 or to tile manufacturer's specification
- Provide horizontal control joints at mid-floors in stairwells in multi-storey buildings
- Place plasterboard control joints over movement joints in the substrate or structural elements and at every change of substrate material
- Utilise floor to ceiling openings as control joints
- Fit double studs or joists, spaced slightly apart, in the frame at control joint locations
- Control joints should extend through cornice.

Notes

Proprietary control joint sections are designed to accommodate normal expansion/contraction movements in plasterboard linings and substrates, and not significant structural movements. Other solutions may be required in such situations.

DESIGN CONSIDERATIONS CONT.

Levels of Finish

The term 'Level of Finish' applies to plasterboard linings prior to decoration.

AS/NZS 2589 Gypsum linings – Application and finishing defines three levels of finish: 3, 4 and 5. Level 4 is the default level of finish for plasterboard linings, unless specified otherwise.

It is essential that the level of finish is determined at the design stage since each level has specific requirements for substrate tolerances and plasterboard installation, jointing and finishing. The desired level of finish may not be achieved unless all of these requirements are met through various stages of construction.

Levels of finish recommended for various lighting conditions and surface decorations are shown in Figure 6.

For the full description of levels of finish and guidelines on assessment of finished surfaces refer AS/NZS 2589.

A summary of various levels of finish is provided below:

Level 3

This level of finish is used in areas that do not require decoration or where finish is not important (for example, above ceiling level or inside service shafts and the like).

All joints and interior angles must have tape embedded in the joint compound and one separate coat of joint compound applied over all joints and fastener heads.

Butt joints and recessed joints in walls and ceilings can be on framing members.

Level 4

This is the default and generally accepted level of plasterboard finish. All joints and interior angles must have tape embedded in the jointing compound and a minimum of two separate coats of joint compound applied over all joints, angles, fastener heads and accessories.

Wall butt joints can be on framing members. If wall butt joints are between framing members, any butt joints longer than 400 mm and less than 2 m above the floor must be back-blocked.

Ceiling butt joints must be between framing members. All ceiling butt joints must be back-blocked. Ceiling recessed joints must be back-blocked in any area containing three or more recessed joints.

If Level 4 surface is to be exposed to critical light (see Glancing Light section), it should be covered with textured finishes or wall coverings. Smooth textured finishes and flat/matt or low sheen paints can be used when Level 4 finish is illuminated by non-critical lighting. Flat paints in this situation tend to conceal joints better.

Weight, texture and sheen level of wall coverings and finishes should be carefully evaluated and joints should be adequately concealed if wall-covering material is lightweight, glossy or lightly patterned.

Level 5

Level 5 finish should be used where gloss or semi-gloss paints are specified or where lining surfaces will be exposed to critical lighting conditions.

Level 5 finish is characterised by a parity of surface texture and porosity. All joints and interior angles must have tape embedded in the jointing compound and a minimum of two separate coats of jointing compound applied over all joints, angles, fastener heads and accessories.

Butt joints in walls and ceilings must be between framing members and back-blocked. Recessed joints in the ceilings must be back-blocked.

The work is finished with proprietary surface preparations or skim coating to remove differential surface textures and porosity. A suitable paint or plaster material is sprayed, rolled or trowelled over the defined area. The surface texture must be random and monolithic, concealing joints and fixing points.

Notes

- If Level 5 finish is desired for a decorated plasterboard surface, this must be specified at the design stage.
- Level 5 finish is difficult to achieve and always requires the cooperation of the framer, plasterer and painter in establishing suitable work practices that deliver the agreed painted finish for the given project.
- Some minor surface variations may still be visible in Level 5 finish, however, these will be minimised.
- The surface of the defined area may require sanding to be suitable for decoration. Roller painting is recommended for Level 5 finish.

DESIGN CONSIDERATIONS CONT.

Table 8: Levels of Finish Requirements Summary

| Level of Finish | Allowed Butt Joints Location | | Ceiling Butt Joints Back-blocking | Ceiling Recessed Joints Back-blocking | | Framing Tolerances* (mm) | | Joining System |
|-----------------|-------------------------------|-------------------------------|-----------------------------------|---------------------------------------|-------------------------------------|--------------------------|----------------|--|
| | Walls | Ceilings | | Less than 3 Recessed Joints in a Room | 3 or more Recessed Joints in a Room | 90% of Area | Remaining Area | |
| 3 | On or between framing members | On or between framing members | Optional | Optional | Optional | 4 | 5 | Tape Coat + Second Coat |
| 4 | On or between framing members | Between framing members only | Must | Optional | Must** | 4 | 5 | Tape Coat + Second Coat + Finishing Coat |
| 5 | Between framing members only | Between framing members only | Must | Must | Must | 3 | 4 | Tape Coat + Second Coat + Finishing Coat + Skim Coat over whole face |

* Maximum deviation at any point of the bearing surface of the finished framing prior to installation of plasterboard linings, when measured with 1.8 m straight edge (refer AS/NZS 2589).

** Level 4 ceilings supported by a ceiling suspension system in accordance with AS/NZS 2785 do not require back-blocking of recessed joints provided there is not rigid connection between ceiling and wall.

Figure 6: Levels of Finish

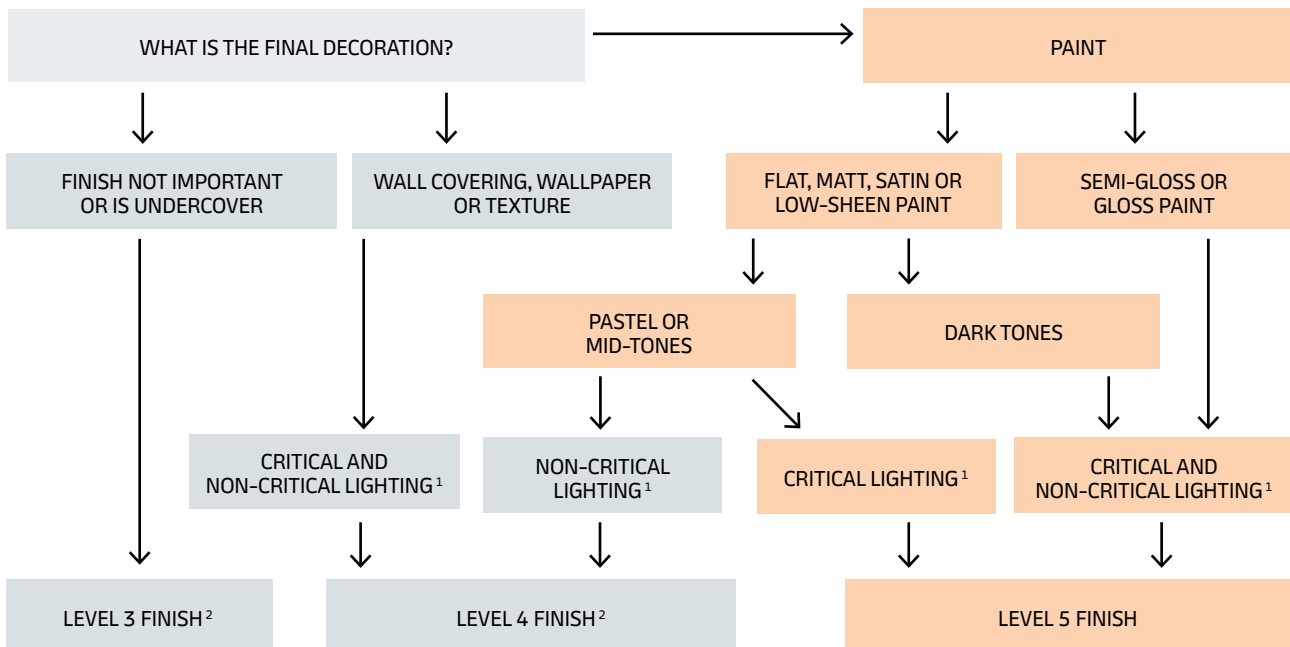

Notes

- ¹ Critical lighting: natural or artificial light projected across a surface at a low incidence angle. Non-critical lighting: when the light striking the surface is diffused or at right angles, or both.
- ² May not be suitable for subsequent decoration to high levels of quality in the future. See Level 4 or Level 5 for upgrading requirements.

DESIGN CONSIDERATIONS CONT.

Glancing Light

Glancing light is the light that shines across a surface rather than directly at it. Glancing light casts shadows from minute undulations that would not normally be visible in diffuse (non-directional) lighting.

While minor surface variations can always be expected (even with a Level 5 finish) the appearance of flatness will depend predominantly on the amount of glancing light the surface receives and to some degree its intensity and direction.

Some of the worst instances of glancing light occur with ceiling-mounted unshaded light globes and where windows are located close to ceilings or walls allowing sunlight to shine across adjacent surfaces.

In order to avoid the effects of glancing light, it is important to carefully plan selection and placement of windows and lighting during the design phase.

Where possible, plasterboard joints should be placed to coincide with the direction of the light. Ceiling battens can assist in altering substrate direction, if required.

Artificial Light

It is recommended that artificial lighting should either be hung below the ceiling surface and fitted with shades, or recessed into the ceiling (i.e. downlights).

Positioning of feature lighting, such as spot and flood lights needs to be planned so that light shining across wall or ceiling surfaces is minimised. Wall mounted lights, shining up on the ceiling, tend to accentuate wall surface variations.

High output lights are more severe in their effect because they create deeper shadows. Similarly, the whiter the light, the stronger the contrast and the greater the perceived surface variations.

Soft, low wattage, diffused lighting provides the most favourable lighting conditions for wall and ceiling surfaces.

Natural Light

The effects of natural glancing light can be exaggerated by late afternoon or early morning sunlight as well as reflections from adjacent walls, roofs and water features such as swimming pools, canals and waterways.

Wall surfaces abutting tall, narrow windows facing the sun (or a reflecting surface) are likely to be affected, as will raked ceilings abutting clerestory windows and flat ceilings abutting window heads.

Where a building design cannot be changed, the effects of glancing light can be minimised by using window shades, soft furnishings, curtains, blinds and pelmets.

Avoid using dark, high-gloss paint finishes as they highlight glancing light problems; instead, use light, matt finishes to minimise the effect.

Figure 7: Plasterboard Surface Under Normal Lighting Conditions

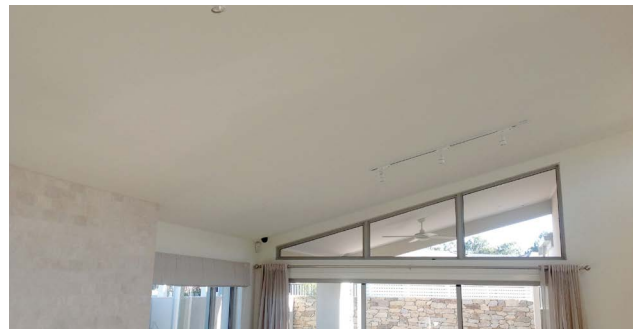

Figure 8: Same Plasterboard Surface Under Glancing Light



Notes

- Knauf publication *Guide to Lighting and Decoration of Plasterboard* provides further guidance to good lighting and decoration practice.
- High intensity halogen floodlights or fluorescent lights should not be used for visual inspection of interior surfaces as they create unfavourable glancing light conditions.

WORKING WITH PLASTERBOARD

Plasterboard Sizes

Standard sizes of select Knauf plasterboard products are shown in the following table:

Table 9: Plasterboard Sizes

| Plasterboard Type | Edge Profile | Thickness (mm) | Width (mm) | Length | | | | | | | |
|----------------------|--------------|----------------|------------|--------|------|------|------|------|------|------|---|
| | | | | 2400 | 2700 | 3000 | 3600 | 4200 | 4800 | 6000 | |
| SHEETROCK ONE | RE | 10 | 1200 | • | • | • | • | • | • | • | |
| | | | 1350 | | | • | • | • | • | • | |
| | RESE | | 1200 | | | | | | | • | |
| | | | 1350 | | | | | | | • | |
| | RE | | 13 | 1200 | • | • | • | • | • | • | • |
| | | | | 1350 | | | • | • | • | • | |
| RESE | 1400 | | | | • | • | | | | | |
| SHEETROCK PLUS | RE | 10 | | 1200 | • | | • | • | • | • | |
| | | | | 1350 | | | | • | | • | |
| WetStop | RE | 13 | | 1200 | • | • | • | • | | | |
| | | | 1350 | | | • | | | | | |
| FireStop | RE | 13 | 1200 | | • | • | • | | | | |
| | | | 1350 | | | | • | | | | |
| | | 16 | 1200 | • | | • | • | | | | |
| | | | 1350 | | | • | | | | | |
| ImpactStop | RE | 13 | 1200 | | | | • | | | | |
| | | | 1350 | | | | • | | | | |
| MultiStop ONE | RE | 13 | 1200 | | | | • | | | | |
| | | 16 | 1200 | | | | • | | | | |
| MultiStop ONE HI | RE | 13 | 1200 | | | | • | | | | |
| Flexiboard | RE | 6.5 | 1200 | | | | • | | | | |
| Shaftliner MouldStop | BE | 25 | 600 | | | • | • | | | | |
| FIBEROCK Aqua-Tough* | RE | 13 | 1200 | | | • | | | | | |
| | | 16 | 1200 | | | • | | | | | |
| GIB X-Block | RE | 13 | 1200 | | | • | | | | | |

Legend: RE – Recessed Edge, SE – Square Edge, RE/SE – Recessed Edge/Square Edge, BE – Bevelled Edge.

*The FIBEROCK Aqua-Tough board sizes supplied by Knauf are in imperial measurements: 15.88 mm x 1219 mm x 3050 mm (5/8" x 4' x 10' IMP) and 12.70 mm x 1219 mm x 3050 mm (1/2" x 4' x 10' IMP). For simplicity and alignment with Australian standards and measurements, we will refer to FIBEROCK Aqua-Tough as 16 mm (for 15.88 mm) and 13 mm (for 12.70 mm) throughout this document.

Notes

- Plasterboard sizes are correct at the time of publication and are subject to change.
- For availability of plasterboard sizes in various regions please contact local Knauf outlet or distributor.
- For the full range of Knauf plasterboard see Knauf.com.

WORKING WITH PLASTERBOARD CONT.

Material Quantities

Plasterboard coverage areas and approximate fixing and jointing requirements are given in the following tables:

Table 10: Fixing and Jointing Compounds per 100 m² of Plasterboard

| Frame Spacing | Walls | | Ceilings | |
|---|-----------------------------|-----------------------------|------------------------------|------------------------------|
| | 600 mm | 450 mm | 600 mm | 450 mm |
| Fixing Method | | | | |
| Nails only | 1250 | 1490 | N/A | N/A |
| Nails and Adhesives | 840 2.9 kg stud adhesive | 870 4.3 kg stud adhesive | N/A | N/A |
| Screws only | 910 | 1050 | 1010 | 1210 |
| Screws and Adhesives | 700 2.9 kg stud adhesive | 750 4.3 kg stud adhesive | 800* 2.9 kg stud adhesive | 900* 4.3 kg stud adhesive |
| Jointing Materials** | | | | |
| Tape | 75 m | | | |
| Base Compounds (First and second coats including angles) | 16 kg to 22 kg | | | |
| Finishing Compounds (Finishing coat only) | 8 kg to 10 kg | | | |

* Conventional fixing method.

** Based on horizontal sheeting. The coverage rates are approximate and should be used as a guide only. The figures may vary significantly due to onsite practices and environmental factors.

Table 11: Board Coverage Area m²

| Width mm | Length mm | Number of Sheets | | | | | | | | | | | | | | |
|-------------|--------------|------------------|-------|-------|-------|-------|-------|-------|-------|-------|-------|--------|--------|--------|--------|--------|
| | | 1 | 2 | 3 | 4 | 5 | 6 | 7 | 8 | 9 | 10 | 20 | 30 | 40 | 50 | 60 |
| 1200 | 2400 | 2.88 | 5.76 | 8.64 | 11.52 | 14.40 | 17.28 | 20.16 | 23.04 | 25.92 | 28.80 | 57.60 | 86.40 | 115.20 | 144.00 | 172.80 |
| | 2700 | 3.24 | 6.48 | 9.72 | 12.96 | 16.20 | 19.44 | 22.68 | 25.92 | 29.16 | 32.40 | 64.80 | 97.20 | 129.60 | 162.00 | 194.40 |
| | 3000 | 3.60 | 7.20 | 10.80 | 14.40 | 18.00 | 21.60 | 25.20 | 28.80 | 32.40 | 36.00 | 72.00 | 108.00 | 144.00 | 180.00 | 216.00 |
| | 3600 | 4.32 | 8.64 | 12.96 | 17.28 | 21.60 | 25.92 | 30.24 | 34.56 | 38.88 | 43.20 | 86.40 | 129.60 | 172.80 | 216.00 | 259.20 |
| | 4200 | 5.04 | 10.08 | 15.12 | 20.16 | 25.20 | 30.24 | 35.28 | 40.32 | 45.36 | 50.40 | 100.80 | 151.20 | 201.60 | 252.00 | 302.40 |
| | 4800 | 5.76 | 11.52 | 17.28 | 23.04 | 28.80 | 34.56 | 40.32 | 46.08 | 51.84 | 57.60 | 115.20 | 172.80 | 230.40 | 288.00 | 345.60 |
| | 5400 | 6.48 | 12.96 | 19.44 | 25.92 | 32.40 | 38.88 | 45.36 | 51.84 | 58.32 | 64.80 | 129.60 | 194.40 | 259.20 | 324.00 | 388.80 |
| | 6000 | 7.20 | 14.40 | 21.60 | 28.80 | 36.00 | 43.20 | 50.40 | 57.60 | 64.80 | 72.00 | 144.00 | 216.00 | 288.00 | 360.00 | 432.00 |
| 1350 | 2400 | 3.24 | 6.48 | 9.72 | 12.96 | 16.20 | 19.44 | 22.68 | 25.92 | 29.16 | 32.40 | 64.80 | 97.20 | 129.60 | 162.00 | 194.40 |
| | 2700 | 3.65 | 7.29 | 10.94 | 14.58 | 18.23 | 21.87 | 25.52 | 29.16 | 32.81 | 36.45 | 72.90 | 109.35 | 145.80 | 182.25 | 218.70 |
| | 3000 | 4.05 | 8.10 | 12.15 | 16.20 | 20.25 | 24.30 | 28.35 | 32.40 | 36.45 | 40.50 | 81.00 | 121.50 | 162.00 | 202.50 | 243.00 |
| | 3600 | 4.86 | 9.72 | 14.58 | 19.44 | 24.30 | 29.16 | 34.02 | 38.88 | 43.74 | 48.60 | 97.20 | 145.80 | 194.40 | 243.00 | 291.60 |
| | 4200 | 5.67 | 11.34 | 17.01 | 22.68 | 28.35 | 34.02 | 39.69 | 45.36 | 51.03 | 56.70 | 113.40 | 170.10 | 226.80 | 283.50 | 340.20 |
| | 4800 | 6.48 | 12.96 | 19.44 | 25.92 | 32.40 | 38.88 | 45.36 | 51.84 | 58.32 | 64.80 | 129.60 | 194.40 | 259.20 | 324.00 | 388.80 |
| | 5400 | 7.29 | 14.58 | 21.87 | 29.16 | 36.45 | 43.74 | 51.03 | 58.32 | 65.61 | 72.90 | 145.80 | 218.70 | 291.60 | 364.50 | 437.40 |
| | 6000 | 8.10 | 16.20 | 24.30 | 32.40 | 40.50 | 48.60 | 56.70 | 64.80 | 72.90 | 81.00 | 162.00 | 243.00 | 324.00 | 405.00 | 486.00 |

WORKING WITH PLASTERBOARD CONT.

Delivery, Handling and Storage

To reduce the risk of damage, plasterboard should be delivered to site just prior to installation.

During handling, sheets should be carried in an 'upright' position with particular care taken to protect the edges.

Plasterboard should be stored in neat, flat stacks off the ground/floor in a dry covered area. This will prevent sagging and minimise damage to board edges and surfaces.

If storing outdoors, stack sheets on a level, moisture-free platform, and keep fully protected from the weather. Ensure the platform can support a load up to 800 kg/m³ density.

Plasterboard stacking supports should be spaced at no more than 600 mm centres (400 mm centres for 6.5 mm Flexiboard).

Refer also to *GBMA Guide to Safe Site Delivery of Plasterboard and Associated Products*.

How to Position a Load

- Billet width and height should be uniform
- Billet length should correspond to plasterboard width, e.g.
 - 1200 mm long billets for 1200 mm wide plasterboard
 - 1350 mm long billets for 1350 mm wide plasterboard

Placing Billets

All billets are to be placed in proper vertical alignment so each tier is evenly supported. If billets are not spaced evenly or in vertical alignment, cumulative pressure on unsupported lower units may cause plasterboard to sag.

Figure 9: Correct Placement of Billets

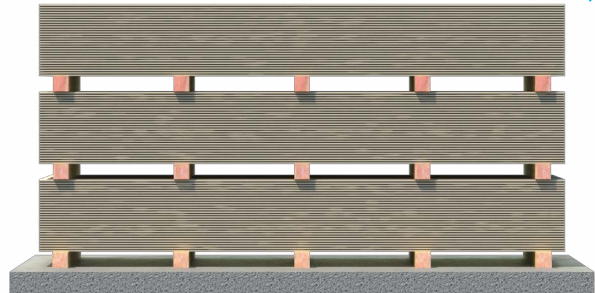

Figure 10: Incorrect Placement of Billets

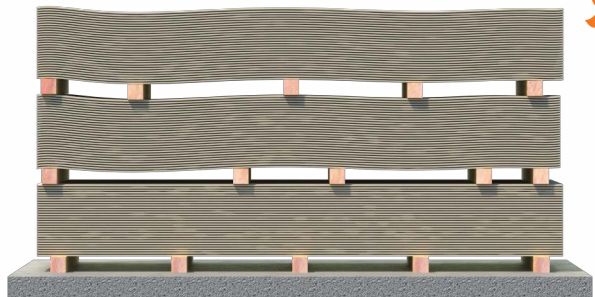
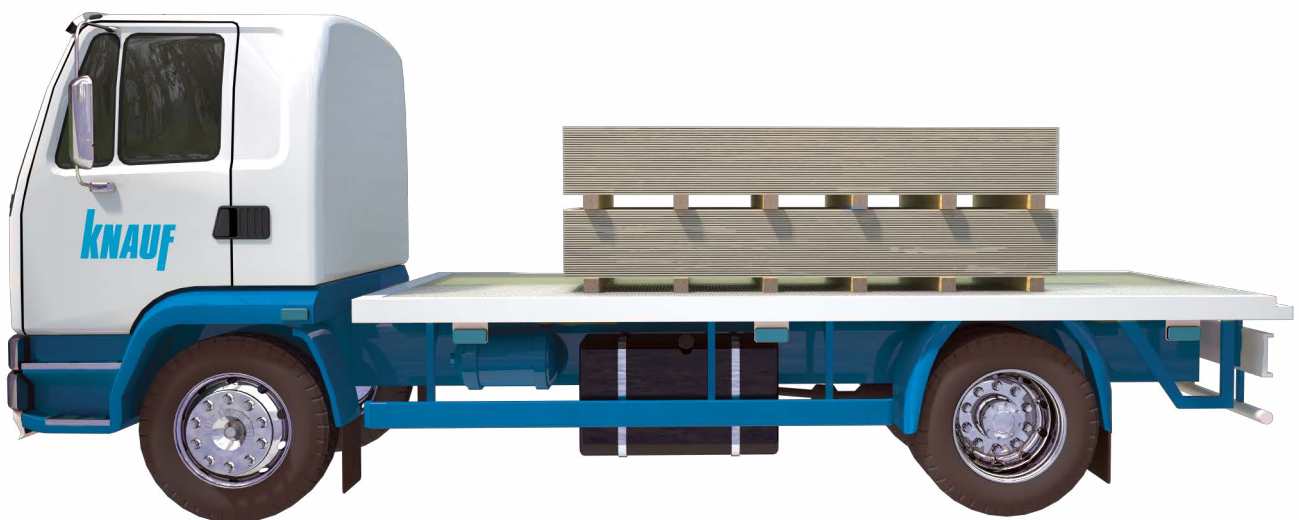

Figure 11: How to Position a Load



Notes

Load restraints of plasterboard have not been shown for clarity, refer to Australian Standards and legislation for requirements.

WORKING WITH PLASTERBOARD CONT.

Framing Check

Prior to installation of plasterboard, framing should be thoroughly checked by builder to ensure that:

- It is plumb, level and square
- Spacing of studs, joists and battens does not exceed the limits specified in the relevant sections of this Manual
- Maximum deviations in the bearing surface of the finished framing do not exceed the maximum tolerances allowed for the required Level of Finish (refer Table 7 Framing Tolerances). Where these tolerances are exceeded, a suitable levelling system should be used
- Noggings supporting services such as taps and cisterns do not protrude beyond the face of the framing
- All openings are framed and ceiling perimeter battens are installed where required
- Trimmers are installed where primary ceiling support members such as girders, trusses and joists, change direction within a room or where required to support ceiling loads
- All contact surfaces are dry, clean and free from foreign materials such as oil, grease and dirt
- Plumbing and electrical services have been installed and do not protrude beyond the face of the framing
- The area is weatherproof.

Fixing Face Requirements

Minimum widths of framing member fixing faces are as follows:

Table 12: Minimum Widths of Fixing Faces (mm)

| Fixing Face Type | Timber Framing | Steel Framing |
|--------------------|----------------|---------------|
| Supporting a joint | 35 | 32 |
| Elsewhere | 30 | 30 |

Plasterboard can be installed directly over existing linings if they are firm, sound and sufficiently flat for the required level of finish (ensure fasteners are of sufficient length by allowing for the thickness of existing linings).

Timber Framing

Timber framing substrates for plasterboard linings must comply with AS 1684 Residential Timber Framed Construction or AS 1720.1 Timber structures; Part 1: Design methods. Roof trusses must comply with AS 4440 Installation of Nailplated Timber Roof Trusses.

For the purposes of determining a suitable plasterboard fixing method, timber falls into the following categories:

Low Shrinkage Timber

Timber with a moisture content under 16% at the time of lining. Generally includes seasoned or kiln dried timbers such as F5/F7 Radiata Pine.

Timber with moisture content at or above 16% but a tangential shrinkage below 8%. Generally includes green timbers such as Radiata Pine, Hoop Pine, Douglas Fir, Cypress Pine, Western Hemlock, Jarrah, Red Narrow-leaved Ironbark, Rose/Flooded Gum and Spotted Gum.

Both mechanical fastener only or combination adhesive/fastener fixing methods can be used for low shrinkage timbers.

High Shrinkage Timber

Timber with moisture content at or above 16% at the time of lining and a tangential shrinkage of more than 8% is categorised as high shrinkage timber. This generally includes timbers such as Mountain Ash, Messmate, River Red Gum, Alpine Ash, Karri and Blackbutt (commonly referred to as Builder's, or OB, Hardwood).

When fixing plasterboard to high shrinkage timbers, a combination adhesive/fastener system must be used.

Treated Timber

Knauf Premium Bond stud adhesive can be used with anti-termite treated or untreated internal timber. H2F treated timber should be aired for a minimum of 14 days prior to application of stud adhesive.

WORKING WITH PLASTERBOARD CONT.

Steel Framing

Steel framed plasterboard substrates must comply with AS/NZS 4600 Cold-formed steel structures, National Association of Steel-framed Housing (NASH) Standard for Residential and low-rise steel framing and AS 1397 Steel Sheet and Strip – hot dipped, zinc coated or aluminium/zinc coated. Steel framing manufacturer to ensure their products satisfy requirements of AS 2753 Adhesive – for bonding gypsum plaster linings to wood and metal framing.

The framing must be assembled and installed in accordance with the manufacturer's instructions.

Notes

Ceiling battens or furring channels are recommended with steel framing due to contraction/expansion movement.

Linings Layout

- Carefully plan installation. Sheets should be set out to ensure best coverage and to minimise butt joints and waste
- Wall sheets should be applied horizontally if a level of finish of 4 or 5 is required. Sheeting may be vertical if it covers the whole wall
- Where possible, sheets should run across doors and windows and be cut out after fixing. The cut-outs can be used to cover small areas
- Full length sheets should be used where possible to eliminate the need for sheet-end butt joints
- Stagger butt joints on adjoining sheets and with those on opposite sides of the wall
- Vertical joints should be kept a minimum of 200 mm from the edge of openings
- Ceiling sheets should be installed with the long edge at right angles to the direction of the support members
- Provide control joints in walls and ceilings

Notes

- Horizontal fixing is the preferred wall sheet orientation or a Level 4 finish as it minimises the effects of glancing light, reduces jointing and places joints at a convenient height for stopping.
- Noggings should not be positioned behind recessed joints in horizontal applications.
- The use of panel lifters will assist in placement and fixing of ceiling sheets.
- Room layout options applies to both timber and steel framing.

Figure 12: Room Layout Option 1

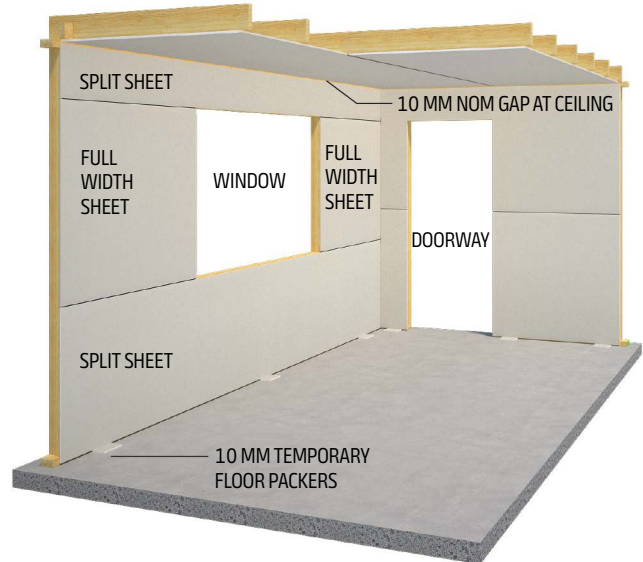
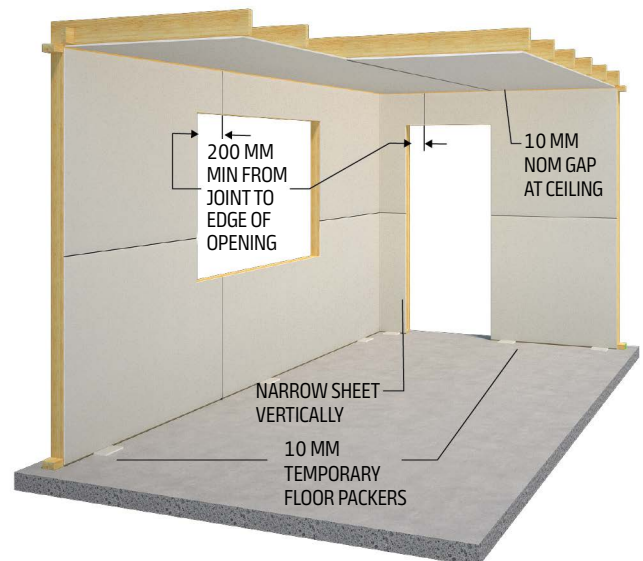

Figure 13: Room Layout Option 2



WORKING WITH PLASTERBOARD CONT.

Plasterboard should preferably be applied to ceilings first and then to walls. This will minimise sheet handling and damage.

Fastening Systems

Plasterboard should be fixed to framing using one of the following fastening systems:

- Combination of adhesive and fasteners
- Screw fixed only
- Nail fixed only.

Notes

- The combination adhesive and fastener system is the preferred option for general applications.
- Combination adhesive and fastener system must be used on High Shrinkage timbers.
- Use a fastener-only system on walls that are to be tiled or that may carry surface-mounted items such as mirrors – do not use adhesive.
- Fastener-only system must be used for fixing of FIBEROCK Aqua-Tough linings.
- Stud adhesive does not constitute a fixing system on its own and must be used in conjunction with screws or nails.
- Avoid fixing plasterboard linings before the installation of ridge capping and the enclosure of gable ends.

Figure 14: Premium Bond Stud Adhesive



General Screw and Nail Fixing

- Plasterboard sheets must be held firm against framing while driving fasteners
- Fixing of the board to commence from centre out
- Screws and nails should be slightly overdriven to allow for stopping but should not break the face paper
- Screws and nails should be positioned 10–16 mm from sheet edges and ends
- Screws should be selected from Tables 12 and 13
- Nails should be selected from Tables 14 and 15
- Screws to be Class 3 or Class 4 as appropriate for the corrosion conditions for wet areas and protected external applications

Plasterboard Fasteners

Screws

Table 13: Plasterboard Screws

| Screw Type | | Application |
|------------|--|---------------------------|
| W |  | Wood/timber only |
| S |  | Steel BMT* up to 0.75 mm |
| D |  | Steel BMT* 0.80 - 2.00 mm |
| L |  | Plasterboard laminating |

* BMT – Base Metal Thickness.





Table 14: Minimum Screw Lengths (mm)

| Plasterboard Lining | Timber | | Steel | |
|---------------------|--------|----------|-------|----------|
| | Walls | Ceilings | Walls | Ceilings |
| 1 x 10 mm | 25 | 30* | 25# | 25# |
| 1 x 13 mm | 30 | 30 | 25# | 25# |
| 2 x 10 mm | 40 | 40 | 30 | 30 |
| 2 x 13 mm | 50 | 50 | 40 | 40 |

* Min 30 mm W screws must be used for ceilings direct fixed to timber framing. Substitution for shorter length screws may increase the risk of screw popping.
 # For ease of construction with framing steel gauges of less than 0.8 mm BMT use 30 mm minimum screw length.

Nails

Table 15: Plasterboard Nails

| Nail Type | | Application* |
|---------------------------------|---|-----------------------|
| Gold Passivated LH Smooth Shank |  | Softwood Wall framing |
| Gold Passivated LH Ring Shank |  | Softwood Wall framing |
| Galvanised LH Smooth Shank |  | Hardwood Wall framing |
| Galvanised LH Ring Shank |  | Softwood Wall framing |

* Knauf does not recommend nail fixing of ceiling linings.

Table 16: Minimum Nail Lengths (mm)

| Plasterboard Lining | Smooth Shank Nails | | Annular Ring Shank Nails | |
|---------------------|--------------------|----------|--------------------------|----------|
| | Softwood | Hardwood | Softwood | Hardwood |
| 1 x 10 mm | 40 | 30 | 30 | 25 |
| 1 x 13 mm | 40 | 30 | 30 | 25 |
| 2 x 10 mm | 50 | 50 | – | – |
| 2 x 13 mm | 65 | 50 | – | – |

INTERNAL CEILINGS

Ceiling Loads and Spans

Plasterboard spans and loads directly supported on ceiling linings must not exceed the maximum values indicated in the following table.

Table 17: Maximum Loads and Spans for Internal Ceilings

| Plasterboard Type | Span (mm) | Maximum Total Load* for Given Wind Class (kg/m ²) | | | |
|----------------------|-----------|---|-------|-------|-------|
| | | N1 | N2 | N3 | N4 |
| 10 mm SHEETROCK ONE | 600 (max) | 2.6** | 2.6** | 2.0 | 2.0 |
| 13 mm SHEETROCK ONE | | | | | |
| 10 mm SHEETROCK ONE | 450 | N/A | | 2.6** | 2.6** |
| 13 mm WetStop | 600 (max) | | | 2.0 | |
| 13 mm ImpactStop | 600 (max) | | | 2.0 | |
| 10 mm SHEETROCK PLUS | 450 (max) | | | 2.0 | |

* Total Load includes weight of insulation and any fixtures directly supported on ceiling linings.
 ** ½ Fixing method must be used if directly supported load exceeds 2.0 kg/m² (maximum load 2.6 kg/m²).

Notes

- Loads in excess of the above must be supported independently from a roof or ceiling structure.
- Roof/ceiling framing must be checked for its capacity to carry supported loads.

Figure 15: Independent Light Fixture Support

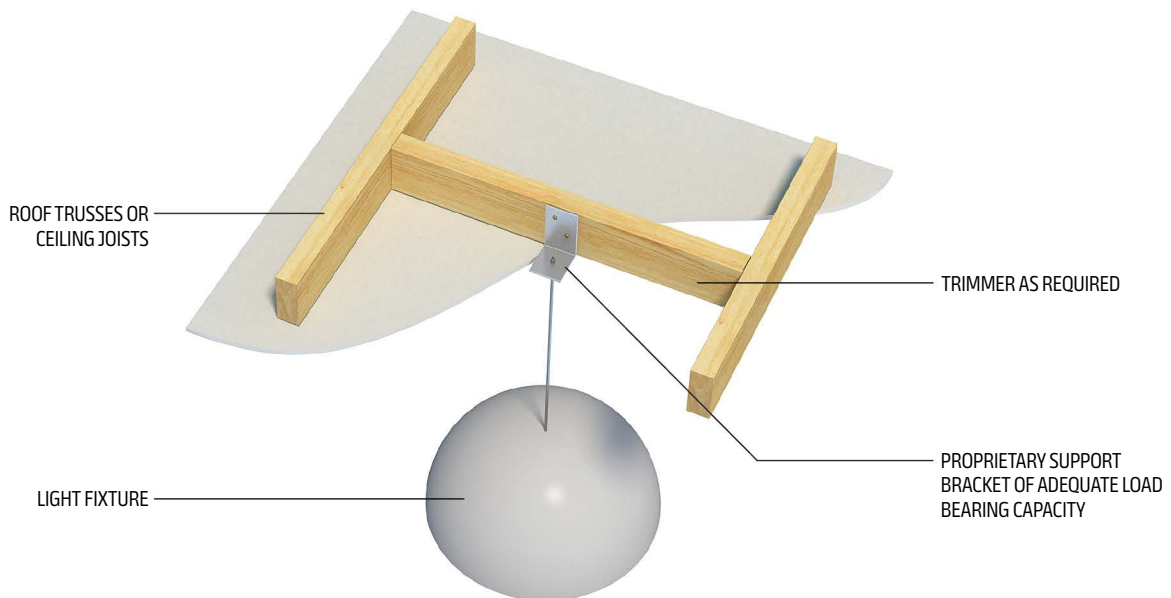

INTERNAL CEILINGS CONT.

Ceiling Support Options

There are two general support options for ceiling linings:

1. Direct fixed, where sheets are fixed directly to structural ceiling members. If plasterboard is direct fixed to structural ceiling members, trimmers are to be installed by the builder where primary ceiling support members such as girder trusses and joists change direction within a room. Trimmer spacing is not to exceed plasterboard spans shown in Table 16.
2. Furred or battened fixing, where sheets are fixed to secondary framing members, such as metal or timber battens or metal furring channels installed in the opposite direction to structural members.

Notes

- Experience has shown that metal battens or furring channels will generally produce a superior ceiling and it is the recommended method for use under trussed roofs and for ceilings with square set finish.
- Ceiling battens and furring channels should stop at least 10 mm clear of non-load bearing internal walls as not to impede truss or floor joist deflection.
- End-to-end joints in Rondo furring channels and 301 batten should be made using appropriate Rondo joiners. Leave 5–10 mm gap between joined sections. Stagger adjacent end-to-end joints between different framing members.

Figure 16: Direct Fixed Ceiling

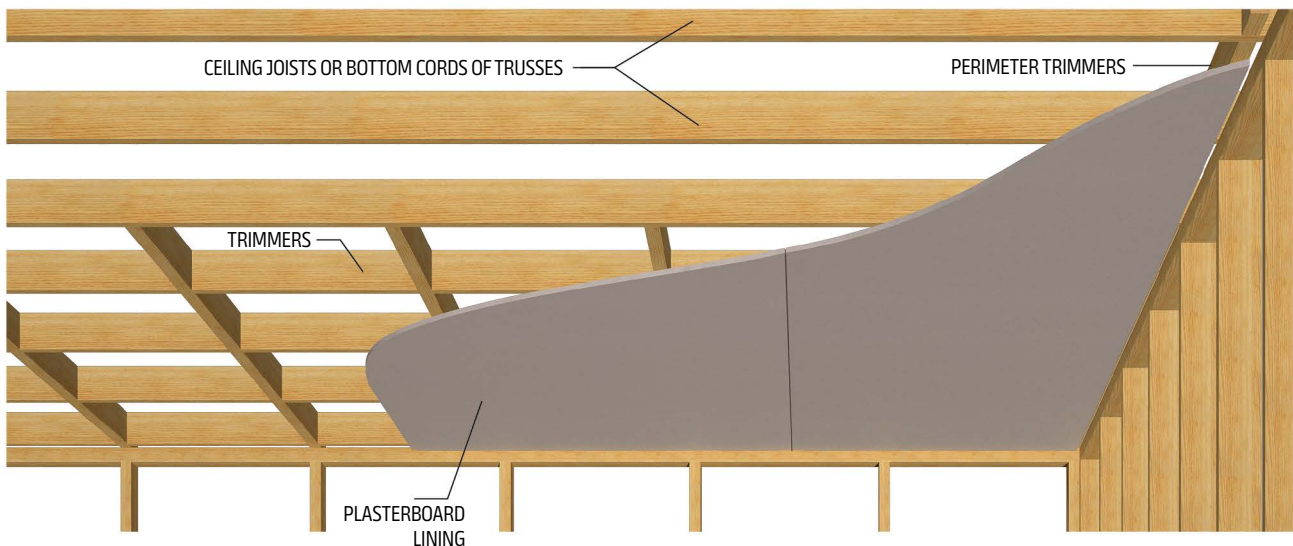
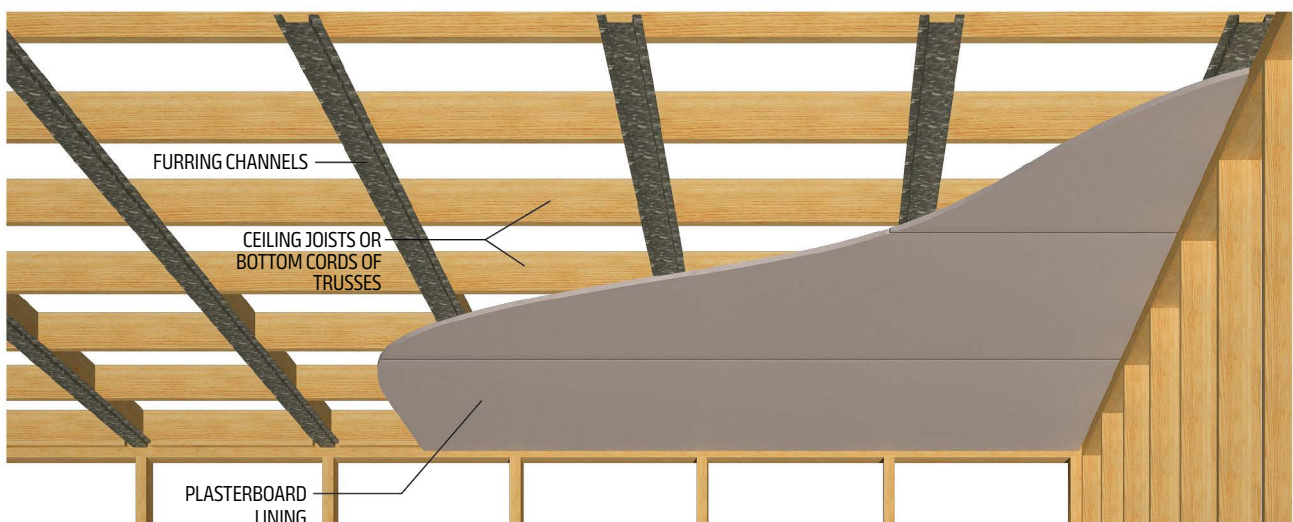

Figure 17: Furred Ceiling



INTERNAL CEILINGS CONT.

Metal Furring Channels and Battens

Knauf recommends the following Rondo metal components for furred plasterboard ceilings:

Figure 18: Rondo Ceiling Components



129 Furring Channel



308 Furring Channel



303 Cyclonic Batten



301 Batten



226 Fixing Clip
(for fixing of 129 and 308 Furring Channels)



394 Fixing Clip
(for fixing of 129 and 308 Furring Channels)



304 Fixing Clip
(for fixing of 301 Batten)



314 Fixing Clip
(for fixing of 301 Battens)



138 Joiner
(for 129 and 308 Furring Channels)



315 Joiner
(for 301 Battens)

Maximum spans of direct fixed, continuous (three or more supports) Rondo furring channels and battens are as follows:

Table 18: Maximum Spans of Continuous 129 Furring Channel (mm)

| Plasterboard Ceiling Lining | Wind Class N2 | | Wind Class N3 | |
|-----------------------------|---------------|--------|---------------|--------|
| | 450 mm | 600 mm | 450 mm | 600 mm |
| 1 x 10 mm | 1713 | 1580 | 1547 | 1428 |
| 1 x 13 mm | 1670 | 1540 | 1519 | 1401 |
| 2 x 13 mm | 1552 | 1432 | 1440 | 1328 |

Source: Rondo Building Services.

Table 19: Maximum Spans of Continuous 308 Furring Channel (mm)

| Plasterboard Ceiling Lining | Wind Class N2 | | Wind Class N3 | |
|-----------------------------|---------------|--------|---------------|--------|
| | 450 mm | 600 mm | 450 mm | 600 mm |
| 1 x 10 mm | 1384 | 1269 | 1253 | 1149 |
| 1 x 13 mm | 1359 | 1245 | 1228 | 1126 |
| 2 x 13 mm | 1170 | 1095 | 1160 | 1064 |

Source: Rondo Building Services.

Table 20: Maximum Spans of Continuous 303 Cyclonic Batten (mm)

| Plasterboard Ceiling Lining | Wind Class N2 | | Wind Class N3 | |
|-----------------------------|---------------|--------|---------------|--------|
| | 450 mm | 600 mm | 450 mm | 600 mm |
| 1 x 10 mm | 1300 | 1200 | 1175 | 1084 |
| 1 x 13 mm | 1267 | 1168 | 1154 | 1064 |
| 2 x 13 mm | 1179 | 1087 | 1093 | 1009 |

Source: Rondo Building Services.

Table 21: Maximum Spans of Continuous 301 Batten (mm)

| Plasterboard Ceiling Lining | Wind Class N2 | | Wind Class N3 | |
|-----------------------------|---------------|--------|---------------|--------|
| | 450 mm | 600 mm | 450 mm | 600 mm |
| 1 x 10 mm | 1200 | 1200 | 1200 | 1120 |
| 1 x 13 mm | 1200 | 1200 | 1200 | 1100 |

Source: Rondo Building Services.

INTERNAL CEILINGS CONT.

Control Joints

Refer to Control Joints section for guidance on control joint locations and construction.

Fixing to Ceilings

Fixing with Combination of Adhesive and Screw Fasteners

General Fixing Notes

- Framing members should be clean and free from dust, dirt, grease and surface moisture
- Refer to General Screw and Nail Fixing
- Stud adhesive daubs should be approx 25 mm diameter x 15 mm high
- Do not use adhesive at sheet ends
- Keep daubs 200 mm (nom) from sheet edges
- Keep daubs 200 mm (nom) from screw points
- At perimeter sheet ends space screws at 300 mm maximum centres for cornices and 150 mm maximum centres for square set finish
- Full perimeter support framing should be provided in each room to fix plasterboard edges
- Take care not to slide plasterboard sheet once in contact with adhesive, to prevent thinly spread of adhesive

Figure 19: Adhesives and Screw Fasteners at Sheet Edges

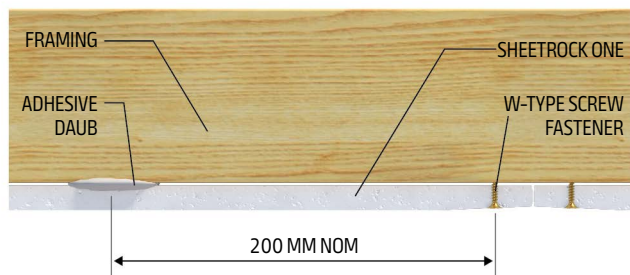

Adhesive and Fastener Layout

1/3 Fixing Method (Preferred)

Space fasteners at 1/3 points across the width of the sheet and daubs half way between fasteners.

Conventional Method

Use double fasteners 50-75 mm apart along the sheet centreline and space daubs between the fasteners at 230 mm maximum centres.

Ceiling fastener and adhesive layouts for both methods are shown in the table below.

Table 22: Adhesive and Fastener Layout for Ceilings

| Sheet Width | Conventional Fixing | 1/3 Fixing |
|-------------|---------------------|------------|
| 900 mm | FAF/FAF | FAFAF |
| 1200 mm | FAAF/FAAF | FAFAFAF |
| 1350 mm | FAAF/FAAF | FAFAFAF |

Legend: F = screw F/F = double screws A = adhesive.

Notes

- 1/3 fixing must be used for ceiling linings applied to H2F treated timber or to painted metal battens.
- Knauf plasterboard has lines printed on the face of the sheet to guide fixing.
- When using conventional method, temporary fasteners (nails or screws driven through plasterboard blocks to hold sheets in place while adhesive cures) should be installed at every second framing member and remain for at least 24 hours.

Fixing With Screws Only

- Space screws at maximum 300 mm centres across the width of the sheet
- At perimeter sheet ends space screws at 300 mm maximum centres for cornices and 150 mm maximum centres for square set finish
- Refer to General Screw and Nail Fixing
- Refer Table 22 and Figure 22 for the number of screwing points across the sheet width
- Full perimeter support should be provided in each room

Table 23: Screw Fixing (only) Layout for Ceilings

| Sheet Width | Screw Points |
|-------------|--------------|
| 900 mm | 4 |
| 1200 mm | 5 |
| 1350 mm | 6 |

Notes

Screw points should be equally spaced.

INTERNAL CEILINGS *CONT.*

Figure 20: Combination Adhesive and Screw Fixing to Ceilings – 1/3 Fixing Method

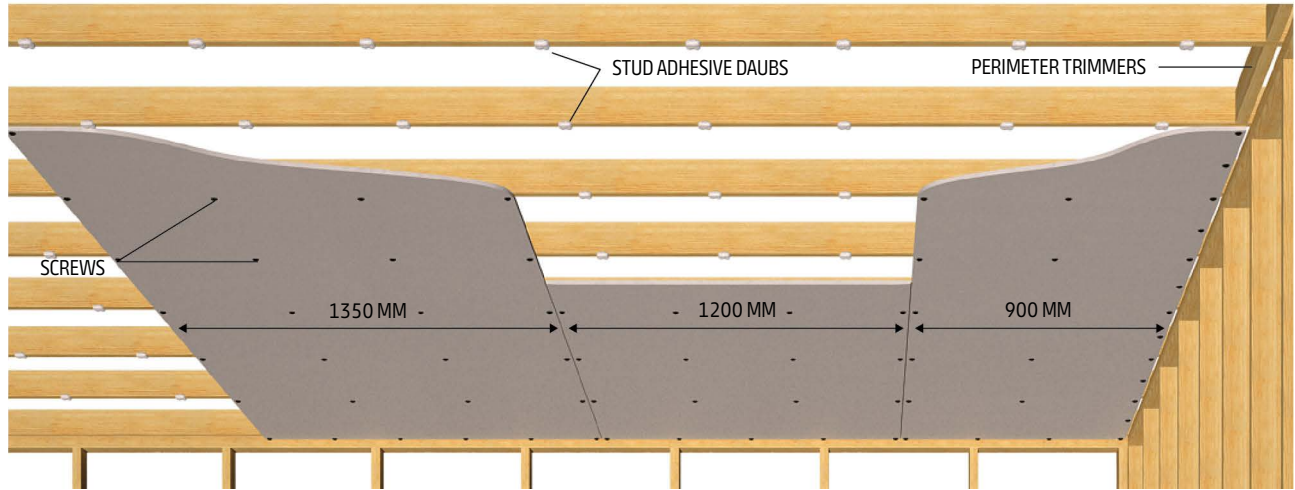

Figure 21: Combination Adhesive and Screw Fixing to Ceilings – Conventional Method

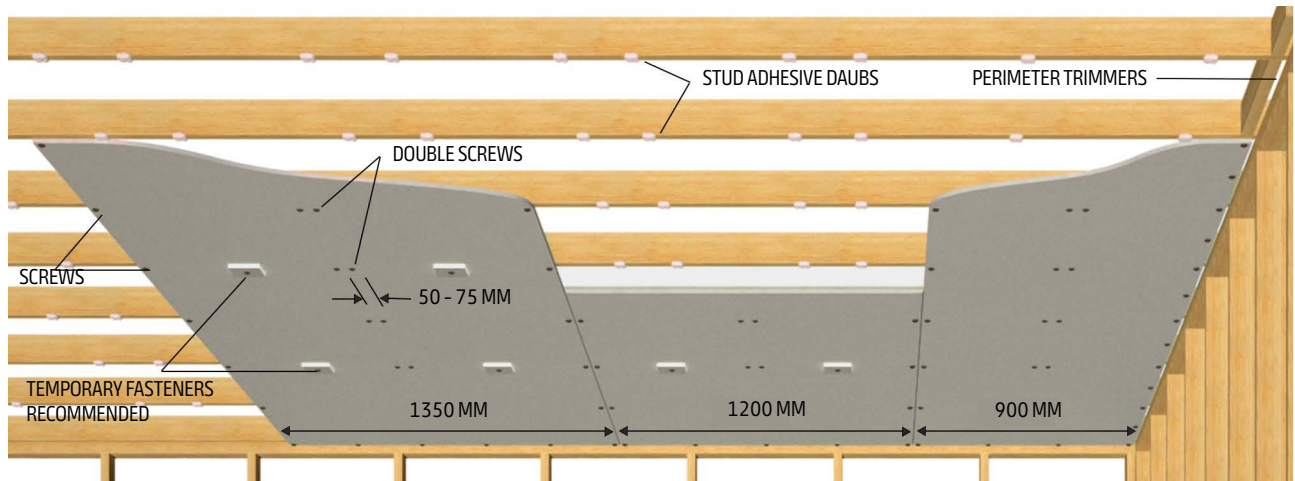
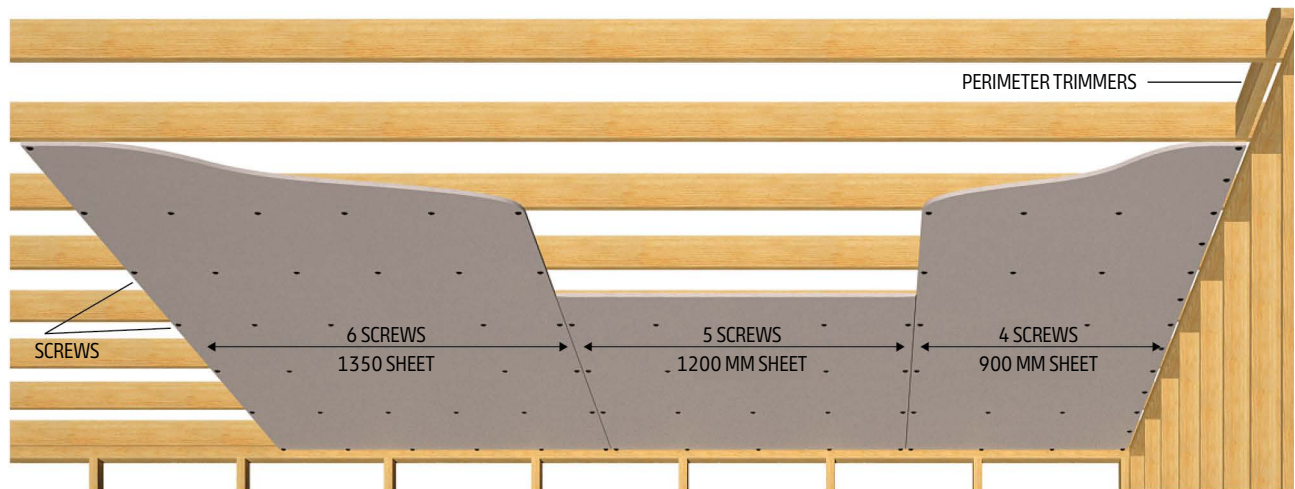

Figure 22: Screw Fixing (only) Layout for Ceilings



INTERNAL CEILINGS CONT.

Back-Blocking

Back-blocking is a reinforcing system designed to minimise cracking and deformation along recessed edge and butt joints.

Back-blocking consists of plasterboard panels adhered to the back of sheet joints. Knauf recommends the use of Knauf Back-Blocking Adhesive or Cornice Adhesive – do not use stud adhesive.

Adhesive should be applied over the full face of the plasterboard pieces, using a 6 mm notched trowel spreader, to form beads of adhesive paste at right angles to the joint.

For best results, back-blocking should occur during plasterboard fixing or immediately after fixing and before the joints are stopped. Australian Standard AS/NZS 2589 Gypsum Lining – Application and finishing requires back-blocking of:

- All butt joints in ceilings
- Recessed joints in Level 4 finish ceilings in any room containing three or more recessed joints
- All recessed joints in Level 5 finish ceilings.

Notes

Knauf recommends that all ceiling joints should be back-blocked.

Butt Joints in Ceilings

Wherever possible, avoid the need for butt joints by using full length sheets.

If sheets must be joined 'end-to-end' then the joints must fall mid-span between framing members and be supported by back-blocking panels (min 400 mm wide) for the length of the joint or between stitching battens (see below).

Back-Blocking Butt Joints

Butt joints can be back-blocked by forming a recess in the plasterboard face, where the sheet ends meet, using Rondo Stitching Batten or temporary wooden battens and packers. Allow back-blocking adhesive to set for a minimum of 24 hours before removing temporary battens.

Figure 23: Rondo Stitching Batten B005

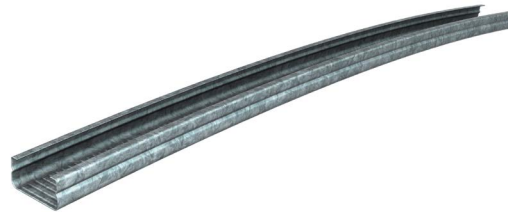

Figure 24: Back-Blocking using Rondo Stitching Batten

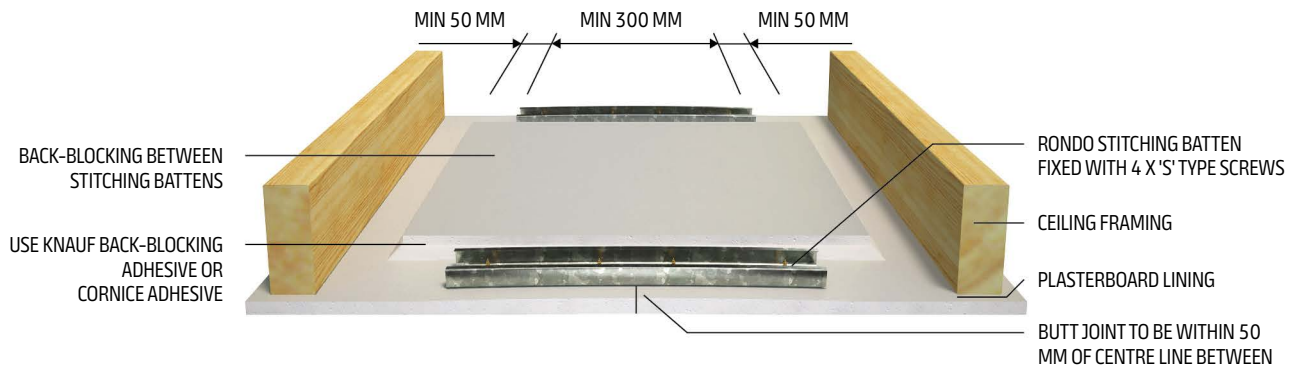
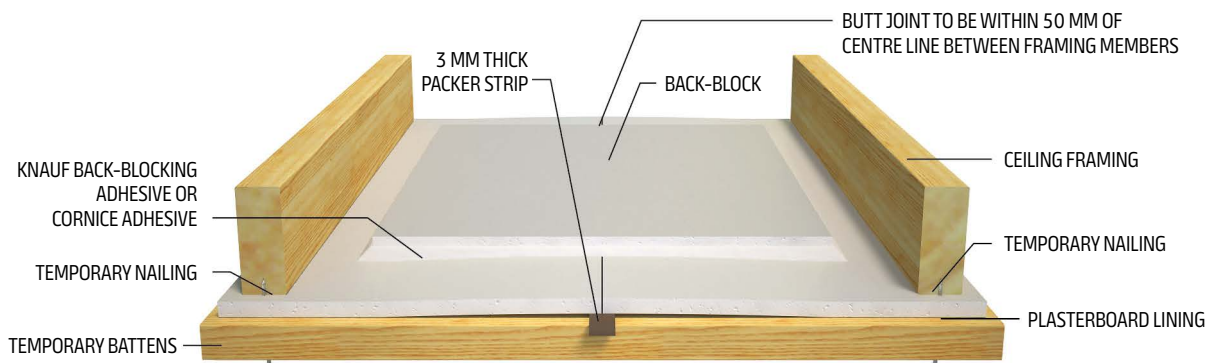
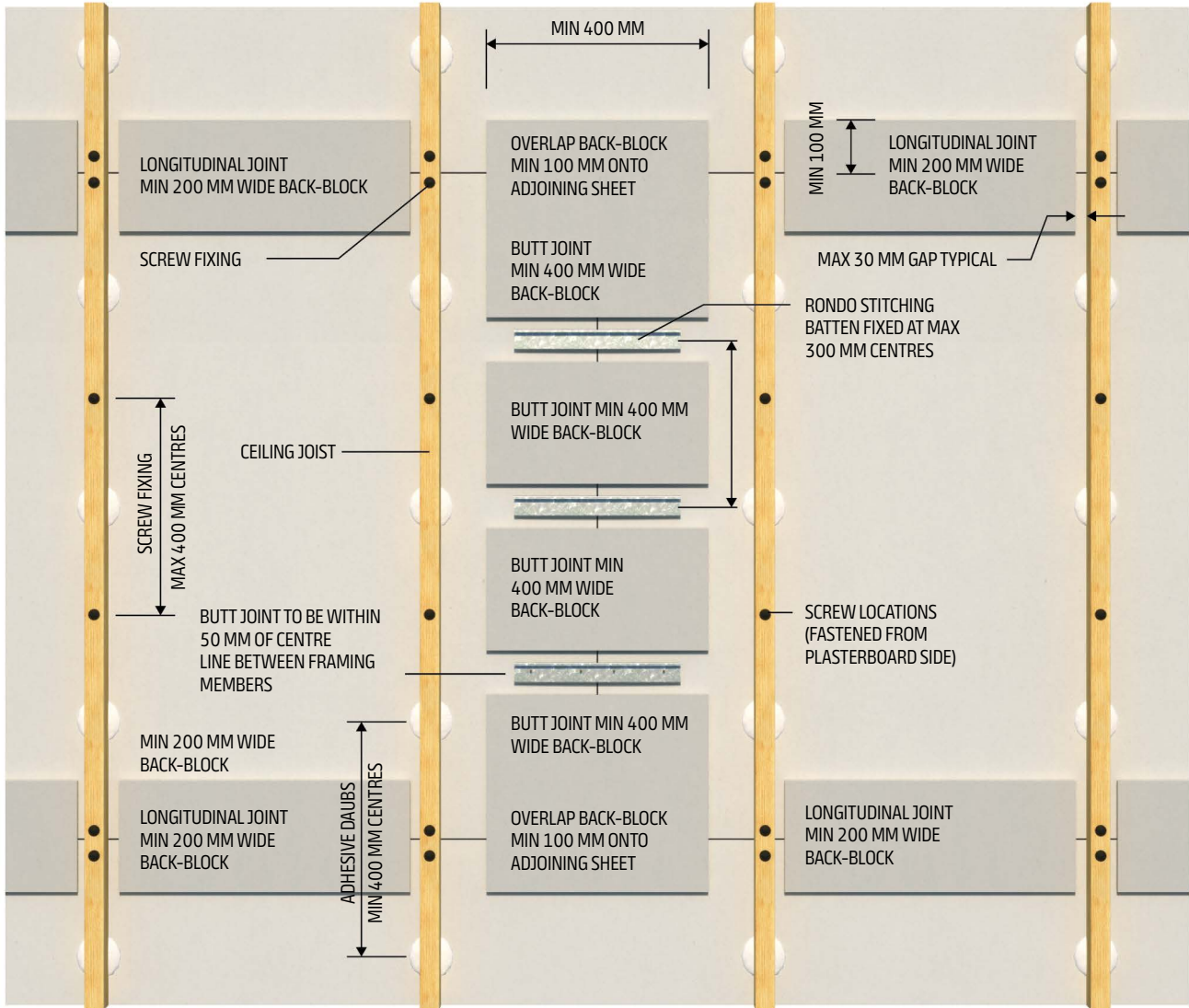

Figure 25: Back-Blocking using Temporary Batten and Packer



INTERNAL CEILINGS *CONT.*

Figure 26: Back-Blocking using Stitching Battens – Plan View



GARAGE AND EXTERNAL CEILINGS

General

Ceilings in garages, carports, verandahs and alfresco areas are subject to more extreme loads and conditions than normal internal ceilings and require special attention to their fixing and detailing.

Some factors contributing to these extra loads include:

- Wind loads
- Condensation
- Roller door vibrations
- Insufficient perimeter support
- Exposure to atmospheric variations (i.e. humidity, temperature, etc).

Notes

- *External ceilings left unpainted for prolonged periods of time should be covered with a sealer coat to reduce the risk of board and compound deterioration.*
- *All Purpose compounds are not recommended for external applications.*
- *Consideration should be given to the use of plastic external angles in highly corrosive environments.*

Design Notes

The following Knauf products are recommended for lining of garage ceilings, alfresco areas and other external protected ceilings in non cyclonic regions:

- 10 mm SHEETROCK ONE
- 13 mm SHEETROCK ONE
- 10 mm SHEETROCK PLUS
- 13 mm WetStop
- 13 mm FIBEROCK Aqua-Tough.

Notes

- *Refer to Figure 27 for maximum frame and screw spacings for garage ceilings.*
- *Refer to Table 23 for maximum frame and screw spacings for external ceilings.*
- *Recommend foil sarking and good ventilation to prevent heat build up and condensation pooling on the top of plasterboard.*
- *Provide a min 6 mm wide gap between the edges of ceiling linings and adjacent walls, beams, columns and fascias.*
- *Fascia boards and perimeter beams should extend min 25 mm below plasterboard to provide a drip edge.*
- *Screws used for fixing of external ceiling linings must be Class 3 or Class 4 as appropriate for the corrosion conditions.*
- *Contact Knauf for applications in cyclonic regions.*

GARAGE AND EXTERNAL CEILINGS CONT.

Installation of Garage Ceilings

- Ensure there are adequate perimeter noggings
- Use the 1/8 Fixing Method as illustrated in Figure 20
- Fasten along the perimeter sheet ends at 300 mm max centres for cornices and at 150 mm max centres for square set finish
- It is recommended that the lower portion of the cornice is mechanically fastened to perimeter timber beams
- Thicken cornice adhesive to avoid dribble on brick wall face
- When adhering cornice to masonry wall, apply Cornice Adhesive to the back of cornice so that it does not squeeze out under the bottom edge
- For maximum loads and spans on garage ceilings refer to Table 16

Figure 27: Garage Ceiling Fixing Layout (1200 mm wide plasterboard sheets shown)

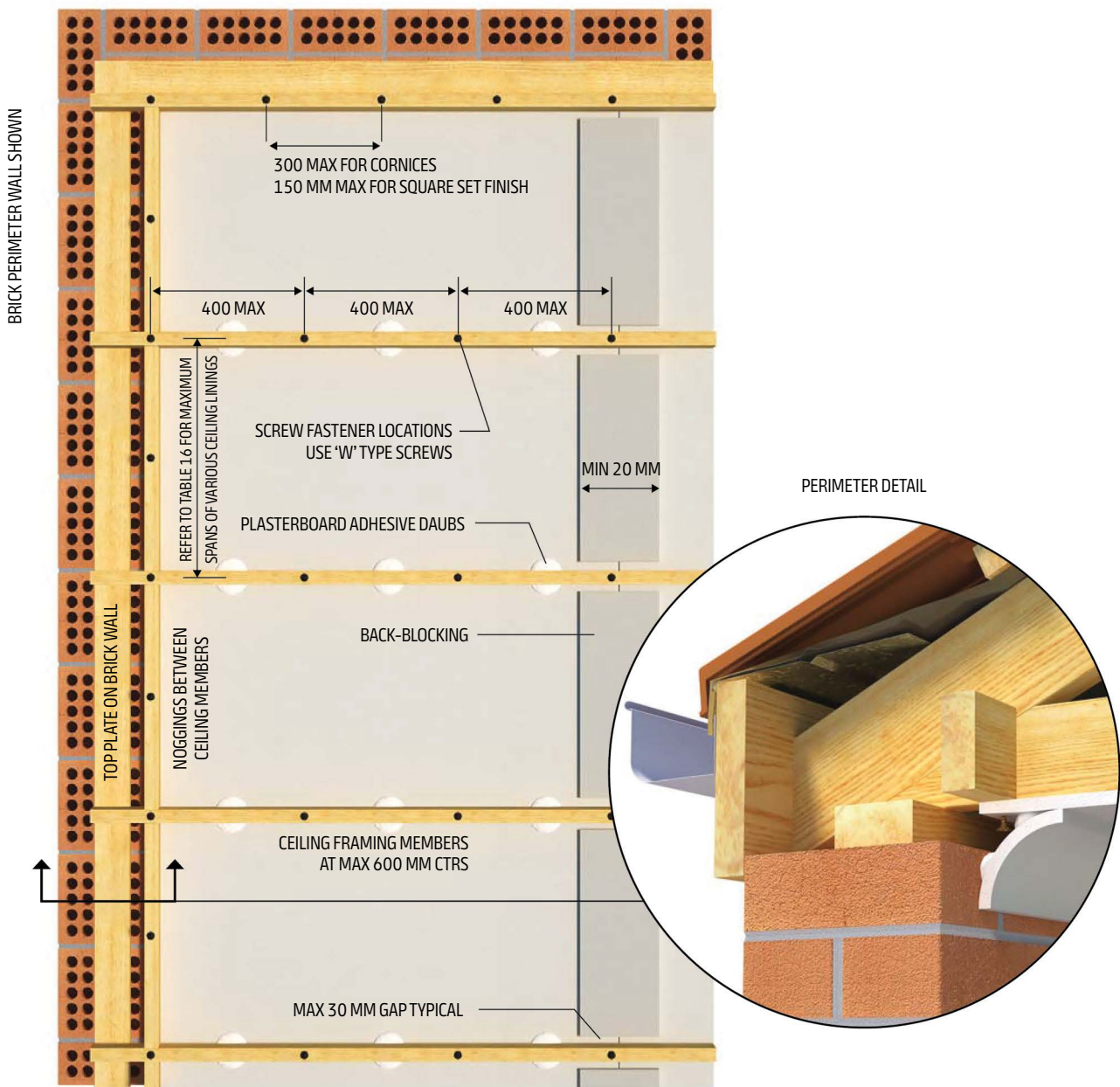

GARAGE AND EXTERNAL CEILINGS CONT.

Installation of External Ceilings

- Spacing between framing members should not exceed the maximum values indicated in Table 23. In areas where these values are exceeded, suitable ceiling battens or furring channels should be provided at required spacings. Metal ceiling battens and furring channels should be installed in accordance with Rondo specifications
- Ceiling linings should be fully screw fixed at maximum spacings indicated in Table 23. Refer Table 12 and 13 for screw type and length
- At perimeter sheet ends/perimeter space screws at 300 mm maximum centres for cornices and 150 mm maximum centres for square set finish
- Run plasterboard sheets at right angles to framing members
- Back-block all joints in ceiling linings as per Knaf back-blocking specifications
- Control joints must be provided in external ceilings at max 6 m centres in both directions
- External ceilings should be painted with a three coat exterior paint system (impervious to moisture and/or include a mould inhibitor) including a sealer undercoat and applied in accordance with the manufacturer's recommendations.
- All plasterboard joints to be set with a base or bedding compound and paper tape. For finishing compound refer to selection chart in this manual

Notes

Air-drying compounds are not recommended to be used as first and taping coat in external ceiling applications.

Table 24: Maximum Framing and Fixing Spacings for External Ceilings

| Ceiling Lining | | Wind Class | | | |
|--|--------------------------|------------|-----|-----|-----|
| | | N1 | N2 | N3 | N4 |
| 10 mm SHEETROCK ONE 13 mm SHEETROCK ONE 10 mm SHEETROCK PLUS 13 mm WetStop 13 mm FIBEROCK Aqua-Tough | Max Framing Spacing (mm) | 450 | 450 | 300 | 300 |
| | Max Screw Spacing (mm) | 300 | 300 | 250 | 200 |

Figure 28: Alfresco Area



GARAGE AND EXTERNAL CEILINGS CONT.

Figure 29: External Ceiling Fixing Layout (1200 mm wide plasterboard sheets)

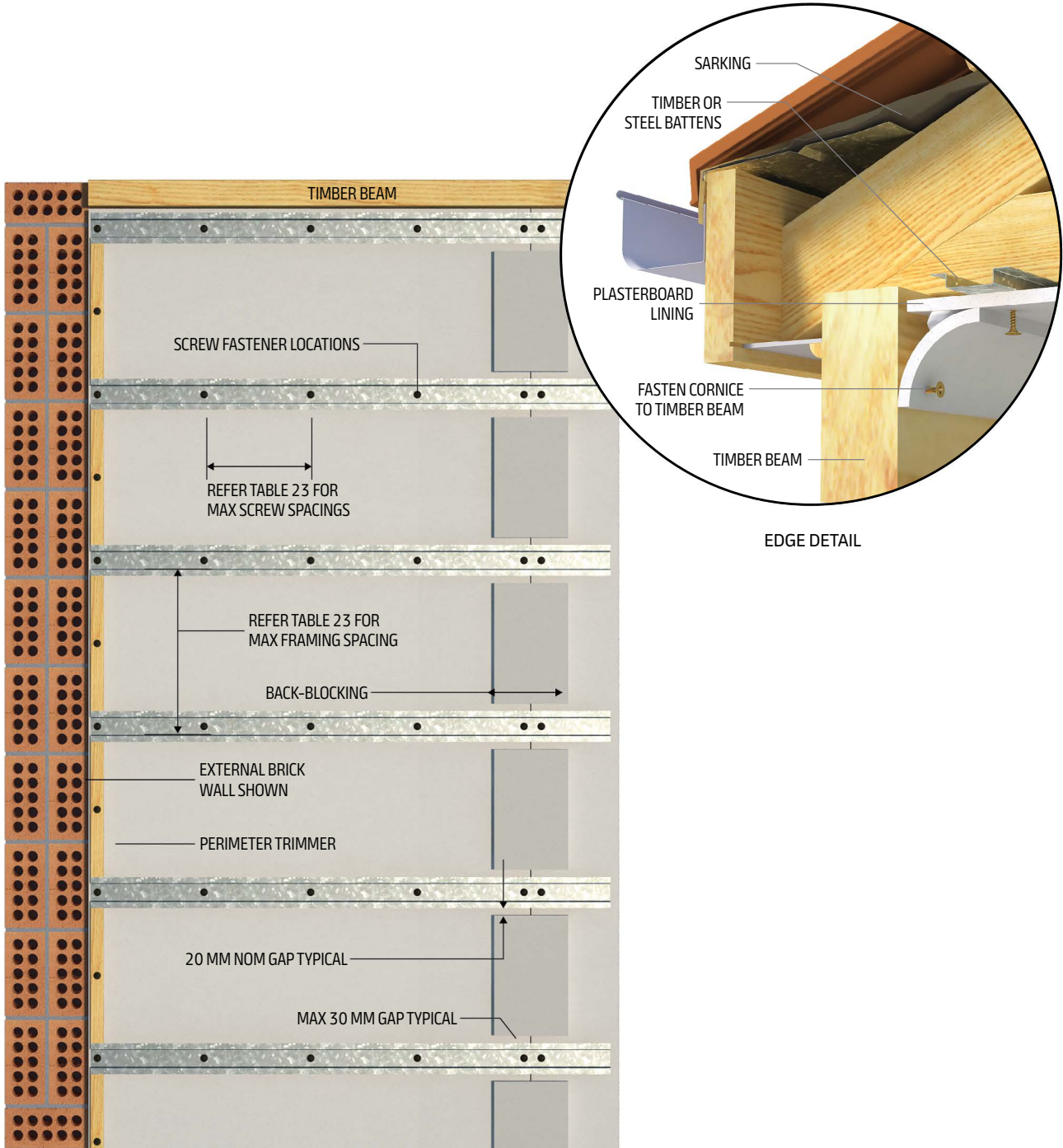

FRAMED WALLS

Fixing with Combination of Adhesive and Fasteners

- Space daubs at 300 mm max centres along the studs
- Space screws or nails at 300 mm max centres at sheet ends (corners)
- Space nails at 150 mm max centres or screws at 200 mm max centres where butt joints are allowed on a framing member (Level 3 and 4 finish only)
- Refer to General Screw and Nail Fixing

Temporary Fasteners

Under normal drying conditions, temporary fasteners (nails or screws driven through plasterboard blocks to hold sheets in place while adhesive cures) must be installed at every second stud and remain for at least 24 hours and must be removed thereafter. In slow drying conditions (e.g. low temperature) refer to adhesive manufacturer for specifications and advice.

Fixing with Screws Only

- Space screws at 300 mm max centres at internal and external corners and around door and window openings
- Space screws at 200 mm max centres where butt joints fall on a framing member (Level 3 and 4 finish only)
- Refer Table 24 and Figure 31 for wall fastener layout
- Refer to General Screw and Nail Fixing

Figure 30: Combination Adhesive and Screw Fixing on Walls

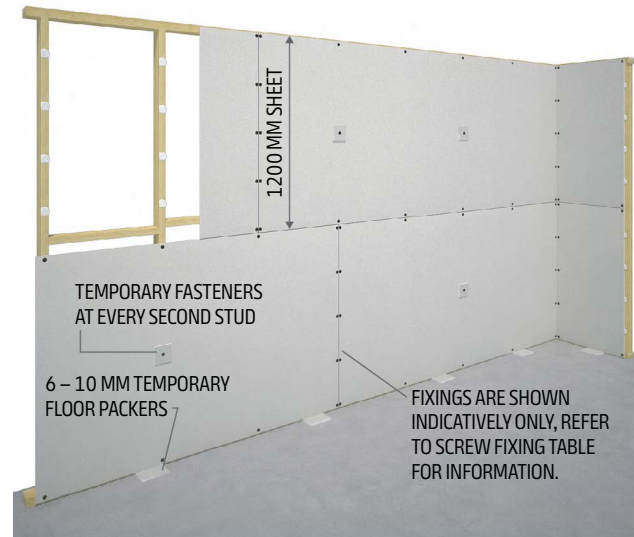

Figure 31: Screw Fixing to Walls

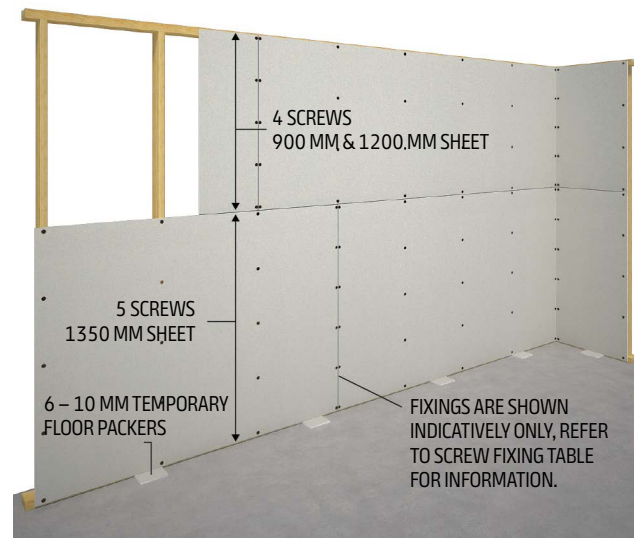

Table 25: Screw Fixing (only) Layout for Walls

| Sheet Width | Screw Points – Field | Screw Points – Sheet End |
|-------------|----------------------|--------------------------|
| 900 mm | 4 | 4 |
| 1200 mm | 4 | 5 |
| 1350 mm | 5 | 6 |

Notes

Screw points should be equally spaced.

FRAMED WALLS CONT.

Fixing With Nails Only (Level 3 finish only)

- Space single nails at 240 mm max centres in the field and at sheet ends (corners)
- Space double nails at 400 mm max centres in the field and at 300 mm max centres at sheet ends (corners)
- Space nails at 150 mm max centres where butt joints are allowed on a framing member (Level 3 finish only)
- Double nails should be 50–75 mm apart
- Refer Table 25 and Figure 32 for min number of nailing points per framing member
- Refer to General Screw and Nail Fixing

Butt Joints in Walls

Wherever possible, avoid the need for butt joints by using full length plasterboard sheets. Butt joints are allowed on framing members for Levels 3 and 4 finish. For Level 5, finish butt joints must be between framing members and back-blocked.

If butt joints are between framing members, the joints should fall within 50 mm of the mid-span between framing members.

Butt joints greater than 400 mm in length and less than 2 m above floor must be back-blocked with min 400 mm wide back-blocking panels for the length of the joint. Butt joints on opposite sides of the wall should fall between different framing members.

Figure 32: Nail Fixing to Walls (single nails)

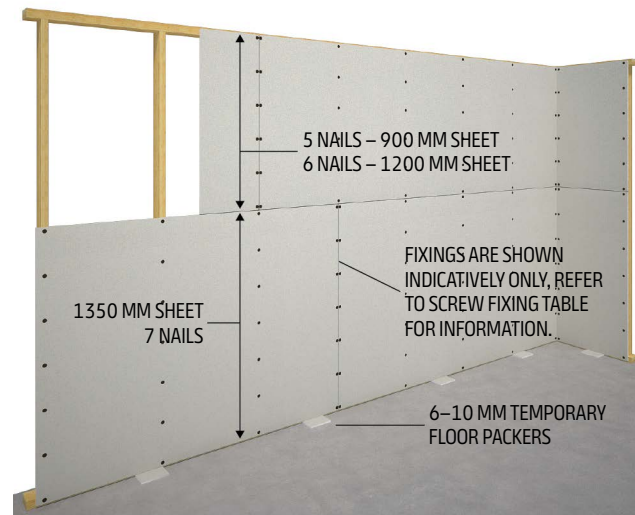

Table 26: Nail Fixing (only) Layout for Walls

| Single Nails | | |
|--------------|----------------------|--------------------------|
| Sheet Width | Nail Points In Field | Nail Points At Sheet End |
| 900 mm | 5 | 5 |
| 1200 mm | 6 | 6 |
| 1350 mm | 7 | 7 |
| Double Nails | | |
| Sheet Width | Nail Points In Field | Nail Points At Sheet End |
| 900 mm | 4 | 4 |
| 1200 mm | 4 | 5 |
| 1350 mm | 5 | 6 |

Notes

Nail points should be equally spaced.

FRAMED WALLS CONT.

Internal Corners

The ends of plasterboard sheets at internal corners may be supported by one of two methods described below.

Where High Shrinkage timber is used the sheets must not be nailed/screwed on either side of the corner and only Method 2 (both sheets floating) may be used. Use a metal angle (Rondo 553) to support sheet ends at internal angles with only one stud.

Method 1 – Both Sheets Fixed

(Internal Corner with 2 studs illustrated).

Figure 33: Internal Corner – Both Sheets Fixed

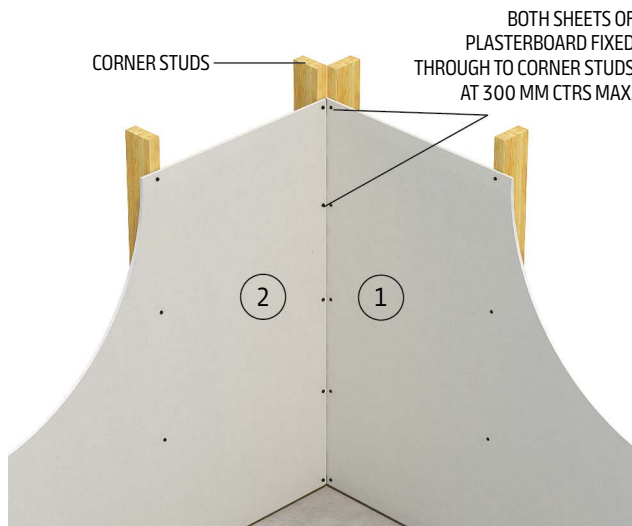

- Fit the underlying sheet (1) firmly into corner and fasten along the edge at 300 mm max centres
- Fit the overlapping sheet (2) with the edge firmly against the first sheet and fasten at 300 mm max centres

Method 2 – Both Sheets Floating

(Internal Corner with 1 stud and metal angle illustrated).

Figure 34: Internal Corner – Both Sheets Floating

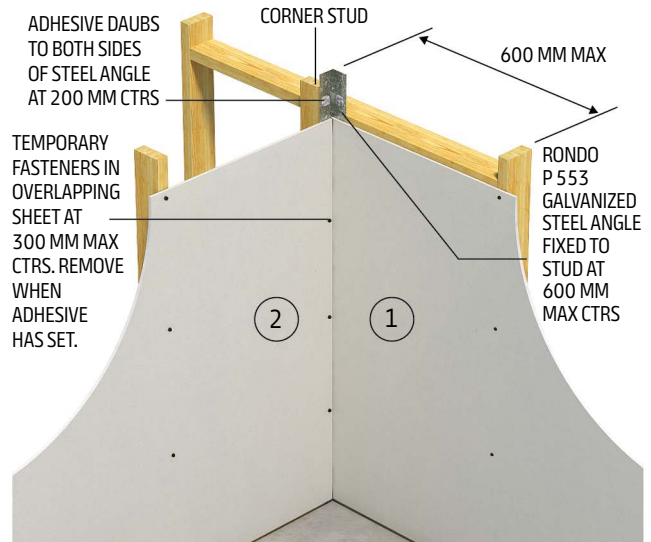

- Cut the metal angle 10 mm shorter than the wall height and fix the angle to the stud at 600 mm centres
- Apply stud adhesive daubs at 200 mm max centres to both sides of the angle
- Fit the underlying sheet (1) fully into the steel angle
- Fit the overlapping sheet (2) hard up against the underlying sheet

Apply temporary fasteners or surface blocks for 24 hours until adhesive has cured. In slow drying conditions (e.g. low temperature, refer to adhesive manufacturer for specification and advice).

Figure 35: Rondo 553 Angle



FRAMED WALLS CONT.

Control Joint Installation

Refer to Control Joint section for guidance on control joint locations and construction.

Installation Procedure (P35 Control Joint):

- Leave gap of 20 mm (nominal) between the ends of plasterboard sheets
- Insert the surface mounted P35 Control Joint in the gap and fix by stapling or nailing on to the board at 300 mm centres
- Stop and finish the joint
- When dry, remove the filament tape, protecting the centre of the P35, to leave a clean, neat joint.

Figure 36: Control Joint in Timber Stud Wall

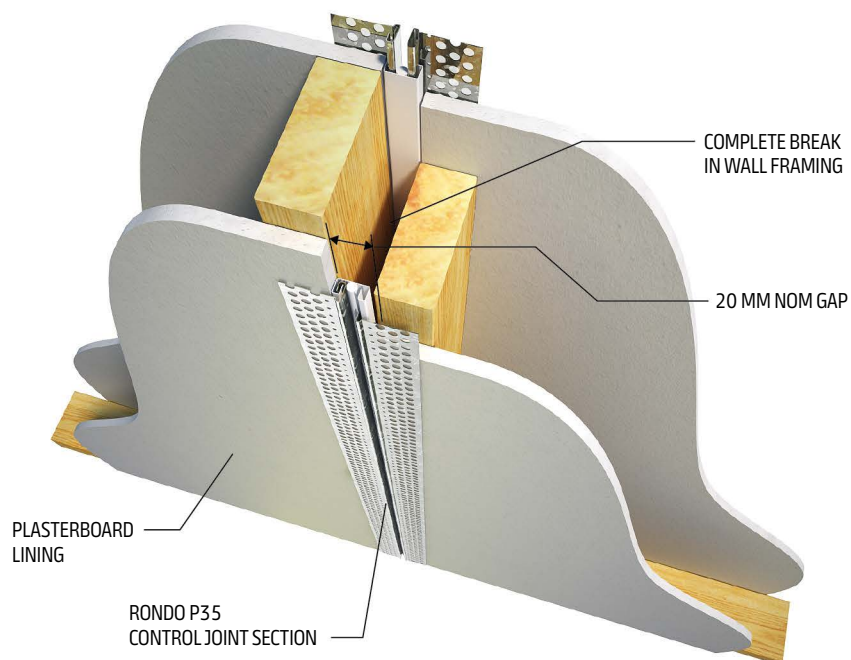

Figure 37: Rondo Control Joint Section P35



FRAMED WALLS CONT.

Door Jamb

Figure 38: Door Jamb with Architraves

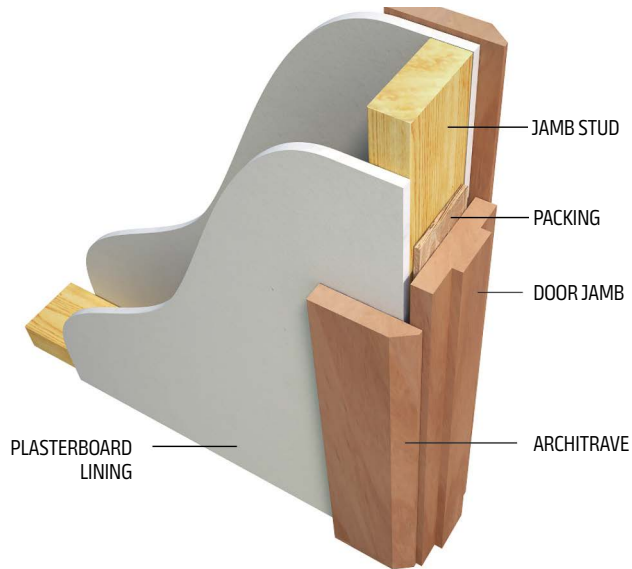
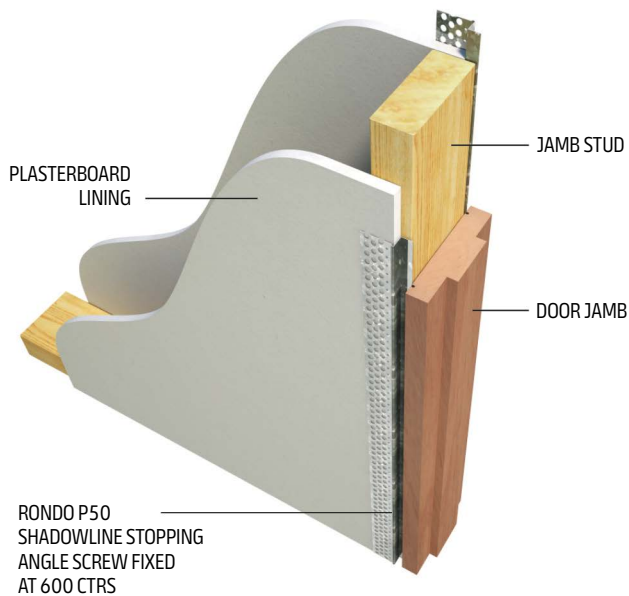

Figure 39: Door Jamb with Shadowline Stopping Angle



Shadowline Stopping Angle

The Rondo P50 Shadowline Stopping Angle can be used to neatly finish plasterboard where:

- A set joint or internal corner is not possible
- Cracking may occur
- A shadowline effect is required such as:
 - Plasterboard and masonry wall junctions
 - Ceiling and wall junctions
 - Door and window jambs.

Figure 40: Rondo Shadowline Stopping Angle P50

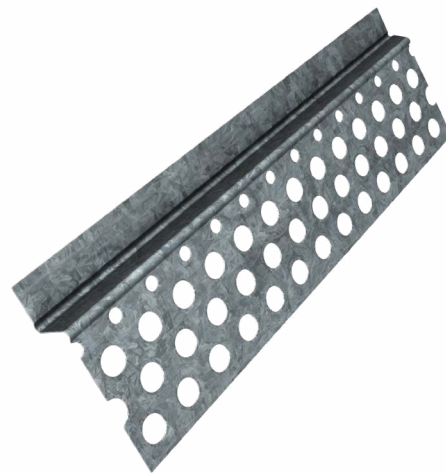

FRAMED WALLS CONT.

Wall-Ceiling Junctions

Common treatments of timber framed plasterboard wall-ceiling junctions include the following:

Figure 41: Cornice Detail

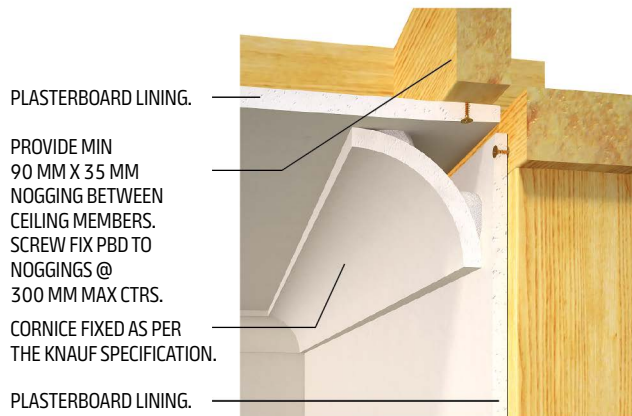

Figure 42: Square Set

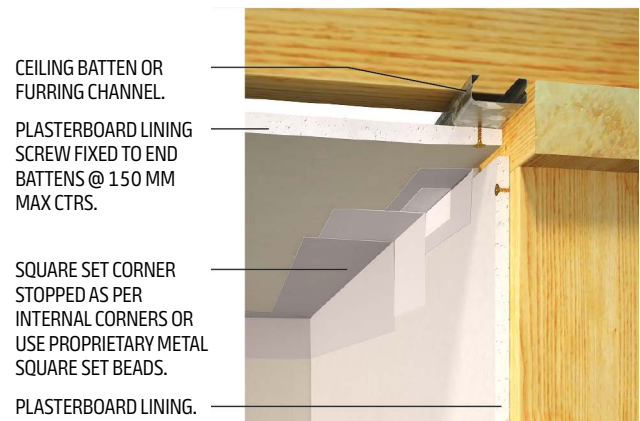

Figure 43: Shadowline Angle 1

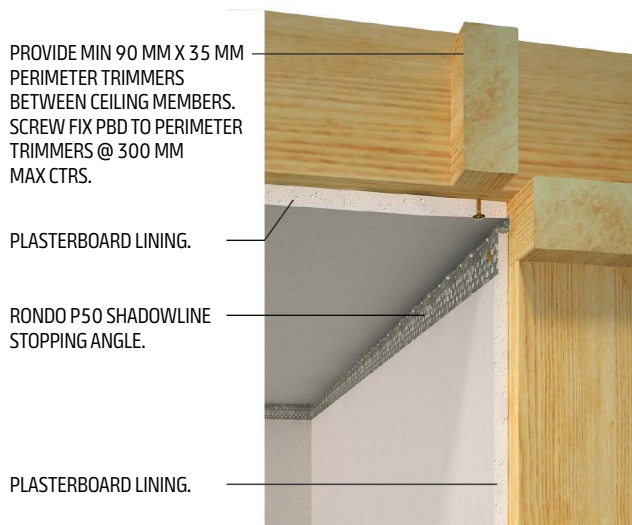
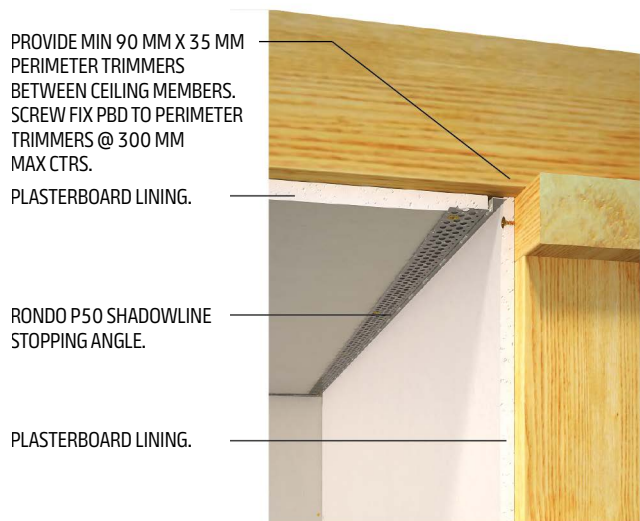

Figure 44: Shadowline Angle 2



Notes

- Ceiling battens or furring channels are recommended for square set finish to minimise the risk of localised cracking.
- The plasterboard details above are applicable for steel framing.
- Ensure steel trimmers are provided to fix plasterboard at the perimeter (similar to timber framing).

MASONRY WALLS

General

Knauf plasterboard provides a dry alternative to cement render and solid plaster finishes over masonry walls.

Two common installation methods are:

1. Fixing sheets directly to masonry using Knauf Masonry Adhesive
2. Fixing sheets over timber battens or metal furring channels fastened to masonry.

The batten/furring channel method will allow a cavity space for services to run between the masonry wall and plasterboard as well as providing a true fixing surface and air flow ventilation.

It is essential that all new masonry surfaces be allowed to dry to in-service levels before installing Knauf plasterboards.

Masonry walls in wet areas, such as bathrooms and laundries must be lined with WetStop or FIBEROCK Aqua-Tough and must be screw fixed to furring channels to manufacturer's design and details.

Notes

Linings in tiled and wet areas must be mechanically fastened to furring channels or timber battens. The use of adhesive is not permitted.

Masonry walls should be checked for flatness and level using a straight edge or string line before determining the fixing method.

Masonry adhesive method should not be used for walls over 3 m high or where the wall surface requires more than 25 mm of packing to bring it back to a true line.

All services should be in place prior to plasterboard installation. Butt joints, control joints, jointing and finishing should be as per standard practice.

Installation Using Masonry Adhesive Method

Masonry walls must be dry and free from dust, oil, flaking paint, efflorescence, release agents, or any other material or treatment that could adversely affect bond strength of masonry adhesive.

Adhesion can also be affected by the porosity, excessive moisture and/or previous surface treatment of a wall. Surface dampening or the use of bonding agent may be required to ensure satisfactory bonding to dry, or porous, walls.

Notes

It is important that plasterboard sheets for masonry applications are stacked flat as misaligned boards can hinder bonding process.

Masonry adhesive may be applied either to a wall or to the back of a sheet. (If gluing plasterboard to Autoclaved Aerated Concrete – AAC – then masonry adhesive should only be applied to the back of the sheet).

It is important to:

- Mix only enough masonry adhesive for stated working time when using setting compounds
- Once setting has commenced the material cannot be remixed and must be discarded
- Hold sheets in position with props or masonry nails until the adhesive has set.

Figure 45: Fixing to a True Wall Surface

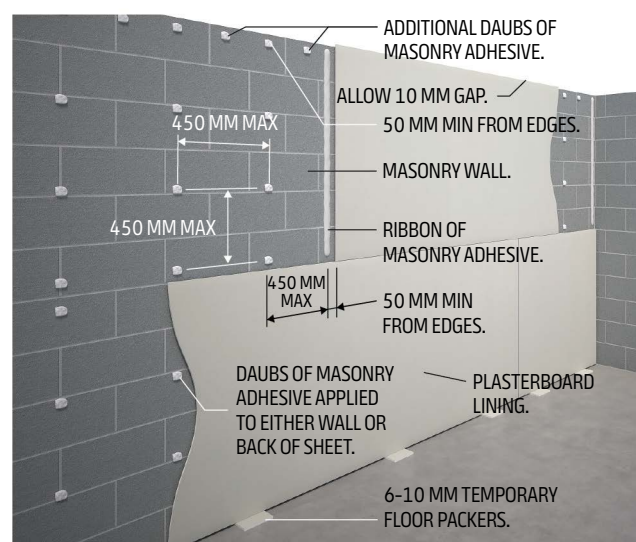

MASONRY WALLS CONT.

Masonry Adhesive Method Installation Notes

- Strike chalk lines on the floor and ceiling as a guide for positioning sheets. Allow for board and daub thicknesses
- Mark lines on the wall to assist in positioning the Masonry Adhesive daubs
- Masonry adhesive daubs should be about 50 mm diameter by 15 mm thickness
- Space adhesive daubs at maximum 450 mm centres vertically and horizontally and 50 mm from free edges and ends of sheets
- Ribbons or additional daubs of masonry adhesive must be applied at sheet ends and at cornice and skirting lines. Additional daubs of masonry adhesive are also required at external angles, fixtures and around services penetrations, doors and windows
- Alternatively, a 'solid wall' effect can be achieved by applying cornice or masonry adhesive to the entire back face of the sheets, using a 15 mm x 15 mm notched trowel
- Keep sheets 6–10 mm off the floor using temporary floor packers
- Place plasterboard and press firmly into position using a long straight edge to level the sheets vertically and horizontally
- Hold sheets in position with props or masonry nails until the adhesive has set
- Once initial contact has been made, boards should not be pulled back from the wall as this will reduce adhesive bond strength
- Once installed, boards should not be disturbed for 48 hours (i.e. no drumming or rattling of walls, cutting of light switches or power points)
- Avoid skinning of masonry adhesive in windy weather or hot conditions
- Avoid early removal of bottom packers

Notes

- Linings in tiled and wet areas must be mechanically fastened to furring channels or timber battens.
- The use of adhesive is not permitted.

Fixing to Irregular Wall Surfaces

Wall surfaces with high/low spots over 15 mm or out of plumb by more than 15 mm will need to be straightened with a series of levelling pads.

Where the cavity between the wall surface and the back of the plasterboard sheet consistently exceeds 17 mm, Knauf Plasterboard's wall furring system, utilising steel furring on steel/timber battens fastened to the base wall, must be used.

Figure 46: Levelling Pads

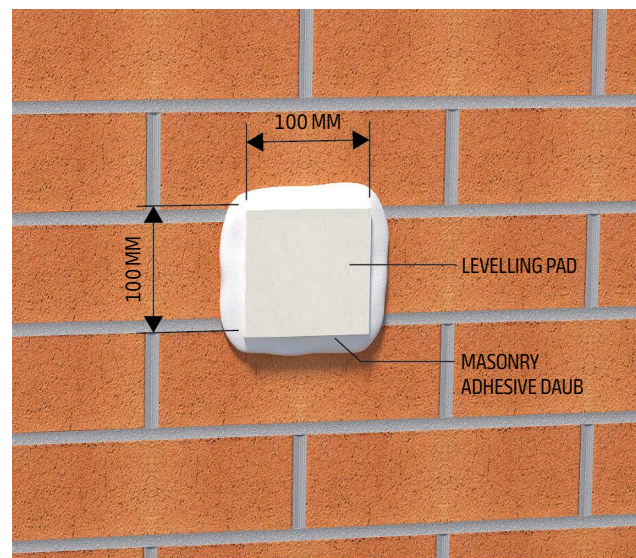

MASONRY WALLS CONT.

Installation Using Battens/ Furring Channels

This installation method is particularly recommended for fixing to precast concrete panels and external masonry walls.

Metal furring channels can either be direct fixed or clipped:

Direct Fixed Battens/Furring Channels

Use one of the following:

- Rondo Recessed Furring Channel 333
- 42 mm x 19 mm (min) timber battens
- Pack where required to achieve a true surface
- Fix to masonry with suitable fasteners.

Clipped Furring Channels

Use one of the following furring channels and fixing clips:

- Rondo 129 or 308 Furring Channel
- Rondo 237 or 239 Fixing Clips
- Rondo Betagrip BG01 or BG02 Fixing Clips
- Set out fixing clips for vertical channels spaced at maximum 600 mm centres and for top and bottom horizontal channels
- Pack clips where required to achieve a true surface
- Fix clips to masonry with suitable fasteners
- Fix plasterboard to furring channels using an appropriate method (adhesive and fasteners or fasteners only) then joint and finish in the normal manner.

Figure 47: Masonry Fixing Clips

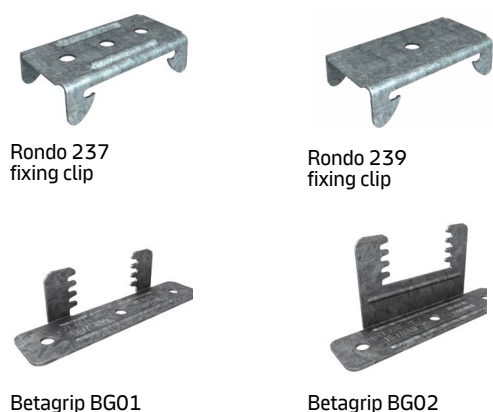

Figure 48: Fixing to Furring Channels Fastened Direct to Wall

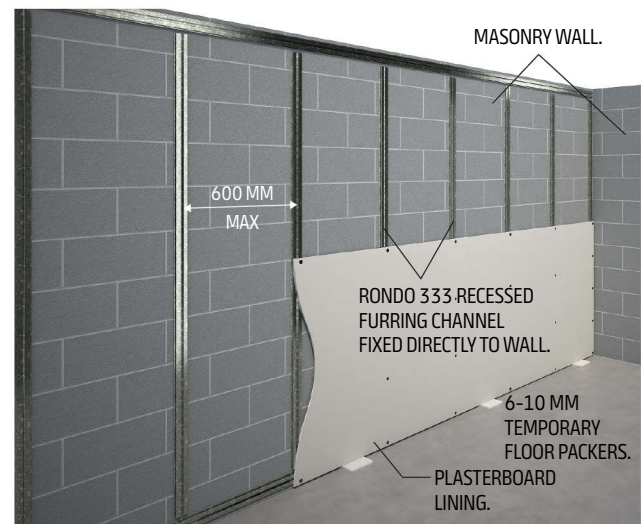

Figure 49: Fixing to Furring Channels Clipped to Wall

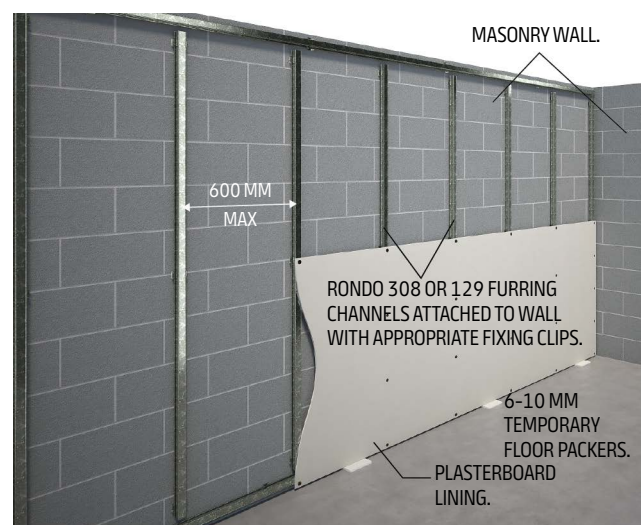

Figure 50: Rondo Recessed Face Furring Channel 333



WET AREAS

Regulatory Requirements

National Construction Code (NCC)

Wet area is defined in NCC as an area within a building supplied with water from a water supply system and includes bathrooms, showers, laundries and sanitary compartments.

According to NCC, wet area walls must be water resistant or waterproof to the extent specified and must comply with AS 3740 Waterproofing of domestic wet areas.

Notes

Knauf Wet Area System requires waterproofing (where indicated in the details) of wet area walls with a waterproofing membrane complying with AS/NZS 4858 Wet area membranes and applied by a specialist contractor in accordance with membrane manufacturer's recommendations.

NCC requires waterproofing of the following junctions and penetrations:

Shower Areas (enclosed and unenclosed)

- Wall junctions within shower areas
- Wall/floor junctions within and outside of shower areas
- Penetrations in shower areas

Areas Adjacent to Baths and Spas

- Wall junctions above inserted baths and spas
- Shelf areas around inserted baths and spas
- Tap and spout penetrations where they occur in horizontal surfaces around inserted baths and spas
- Where a shower is above bath or spa, use requirements for shower.



WET AREAS CONT.

Walls Adjoining Other Vessels (ie. sink, basin or laundry tub)

- Wall junctions where a vessel is fixed to a wall
- Tap and spout penetrations where they occur in surfaces required to be waterproof or water resistant

Laundries and WCs

- Wall/floor junctions within laundries and WCs
- Tap and spout penetrations where they occur in surfaces required to be waterproof

Bathrooms and Laundries Required to Provide a Floor Waste

- Wall/floor junctions

Notes

See also NCC State & Territory Appendices for additional waterproofing requirements in South Australia.

AS 3740 Waterproofing of Domestic Wet Areas

AS 3740 sets out minimum material, design and installation requirements for waterproofing of wet areas within residential building and other buildings with similar usage intensity. It also outlines acceptable wet area materials and construction methods.

AS 3740 requirements include waterproofing of:

- All cut edges in water resistant plasterboard that have potential to be affected by moisture (including the bottom edge over a preformed shower base)
- Penetrations for taps, shower nozzles, recessed soap holders and similar fixtures by sealing with proprietary flange systems or a sealant
- Any penetrations of mechanical fixings or fastening through surface materials
- Membranes meeting the requirements of AS/NZS 4858.

For the purposes of AS 3740:

- Water-resistant plasterboard manufactured to AS/NZS 2588 *Gypsum Plasterboard* constitutes a water resistant substrate for tiles or other nominated water resistant surface materials
- Membranes meeting the requirements of AS/NZS 4858 are deemed to be waterproof materials when used in waterproofing systems.

AS/NZS 4858 Wet Area Membranes

AS/NZS 4858 sets out the performance and general test requirements for waterproof membranes as defined in AS 3740.

AS/NZS 4858 classifies membranes by their extensibility and requires the use of appropriate bond breakers for various classes of membranes.

Table 27: Waterproofing Membranes

| Membrane Class | Extensibility | Elongation at break | Min bond breaker width to bridge joints opening up to 5 mm |
|----------------|---------------|---------------------|--|
| I | Low | 10-59% | 100 mm |
| II | Medium | 60-299% | 35 mm |
| III | High | ≥ 300% | 12 mm |

WET AREAS CONT.

Knauf Wet Area System

Knauf Wet Area System comprises materials and installation details outlined in this manual and must be installed in accordance with Knauf specification to achieve the required performance. Knauf Wet Area System complies with the requirements of AS 3740 and is thus suitable for use in residential buildings and other buildings with a similar usage pattern.

Knauf Wet Area System is not suitable for use in high exposure applications such as group shower rooms, steam rooms, etc. or in areas of high humidity (above 90% RH).

Wet Area Materials

WetStop and SHEETROCK PLUS

Knauf WetStop and SHEETROCK PLUS plasterboard complies with water resistant requirements of AS/NZS 2588.

Its water resistant core limits water wicking up the board causing damage to the board itself or to surface finish. WetStop and SHEETROCK PLUS can be identified by their blue-grey face liner and are manufactured with recessed edges, allowing for flush jointing both within and outside tiled areas.

WetStop and SHEETROCK PLUS complies with water resistant requirements of AS 3740.

WetStop is available in a 13 mm thickness, while SHEETROCK PLUS is available in a 10 mm thickness.

FIBEROCK Aqua-Tough

Fiberock Aqua-Tough is a water resistant paperless gypsum board offering additional benefits of mould resistance and high impact resistance. Fiberock Aqua-Tough contains 95% recycled materials.

Manufactured with recessed edges for flush jointing, Fiberock Aqua-Tough can be used as an alternative wall lining in Knauf Wet Area System and can be installed using the same fixing, jointing and waterproofing materials and details as specified for WetStop.

Recessed edge Fiberock Aqua-Tough is available in 13 mm and 16 mm thicknesses.

Waterproof Sealant

A suitable flexible waterproof sealant must be used to seal the sheet ends of water resistant plasterboard to other surfaces, including:

- Wall junctions and cutouts
- Bottom of sheets in shower bases or bath abutments
- Around plumbing fixtures and penetrations.

Waterproofing Membrane

Proprietary waterproofing membrane complying with the requirements of AS/NZS 4858 *Wet Area Membranes* and installed by a specialist contractor must be applied over the whole face of wet area walls in accordance with membrane manufacturer's recommendations.

Corner Support Angle

40 mm x 40 mm galvanised metal angle Rondo P40 is used to support waterproofed internal corners in wet areas. It is available in 1.8 m lengths.

Preparation of Wet Areas

Check framing for layout and fixing of additional noggings to support wet area fittings such as screens and taps and the continuous support for Knauf water resistant linings at the shower base and bath rims.

Provide adequate noggings 25 mm (nominal) above bath, shower bases, tubs and sinks for fixing the edges of Knauf water resistant linings.

Ensure that plumbing pipes and noggings do not protrude beyond the face of the studs.

Recess preformed shower bases and baths into studs so that Knauf water resistant linings can sit correctly in front of the shower base upstand. This will provide a natural flashing point.

Ceilings over Wet Areas

As the NCC does not require the use of water resistant ceiling linings over wet areas, SHEETROCK plasterboard provides an adequate solution for this application. SHEETROCK PLUS, WetStop or FIBEROCK Aqua-Tough can be used in wet area ceilings if water resistant linings are desirable.

Ceiling linings over wet areas in residential buildings can be fixed as per the standard internal ceiling installation specification.

FIBEROCK Aqua-Tough gypsum board must be fully mechanically fixed (screws only).

Notes

Knauf recommends that ceiling paint in wet areas should be impervious to moisture.

WET AREAS CONT.

Installation in Tiled Areas

- Knauf water resistant linings in tiled areas must be fixed using a full fastener (screws only) system. Adhesive is not permitted
- Space fasteners as per Table 27 and 28, and Figure 51
- Sheets can be fixed horizontally or vertically with the bottom edge 6–10 mm clear of the finished floor level or fixture
- Lining sheets are best run the full length of the wall to avoid butt joints
- Ensure sheets sit flat against framing
- Neatly cut out penetrations and holes using hole saw and allowing approx 6 mm gap for waterproof sealant
- Fix 40 mm x 40 mm corner support angles where required for waterproofed internal corners leaving a 6 mm gap at the bottom
- Use screws as indicated in Tables 12 and 13

Installation in Non-Tiled Areas

SHEETROCK PLUS and WetStop in non-tiled areas may be fixed as per standard installation specifications.

FIBEROCK Aqua-Tough in non-tiled areas must be fixed using screws only.

Table 28: Plasterboard Fastener Spacing in Tiled Areas

| Wall Tiles Weight (including tile adhesive) | Max Fastener Spacing | |
|--|----------------------|------------|
| | Intermediate Studs | Sheet Ends |
| No greater than 12 kg/m ² | 200 mm | 150 mm |
| Greater than 12 kg/m ² up to 32 kg/m ² max | 100 mm | 100 mm |

Table 29: FIBEROCK Aqua-Tough Fastener Spacing in Tiled Areas

| FIBEROCK Aqua-Tough Thickness mm | Wall Tiles Weight (including tile adhesive) | Max Fastener Spacing | |
|----------------------------------|--|----------------------|------------|
| | | Intermediate Studs | Sheet Ends |
| 13 mm or 16 mm | No greater than 12 kg/m ² | 300 | 200 |
| | Greater than 12 kg/m ² up to 32 kg/m ² max | 200 | 150 |
| | Greater than 32 kg/m ² up to 50 kg/m ² max | 150 | 100 |

Figure 51: Plasterboard Fixing in Tiled Areas

TILES UP TO 12 KG/M²

TILES GREATER THAN 12 KG/M² UP TO 32 KG/M² MAX

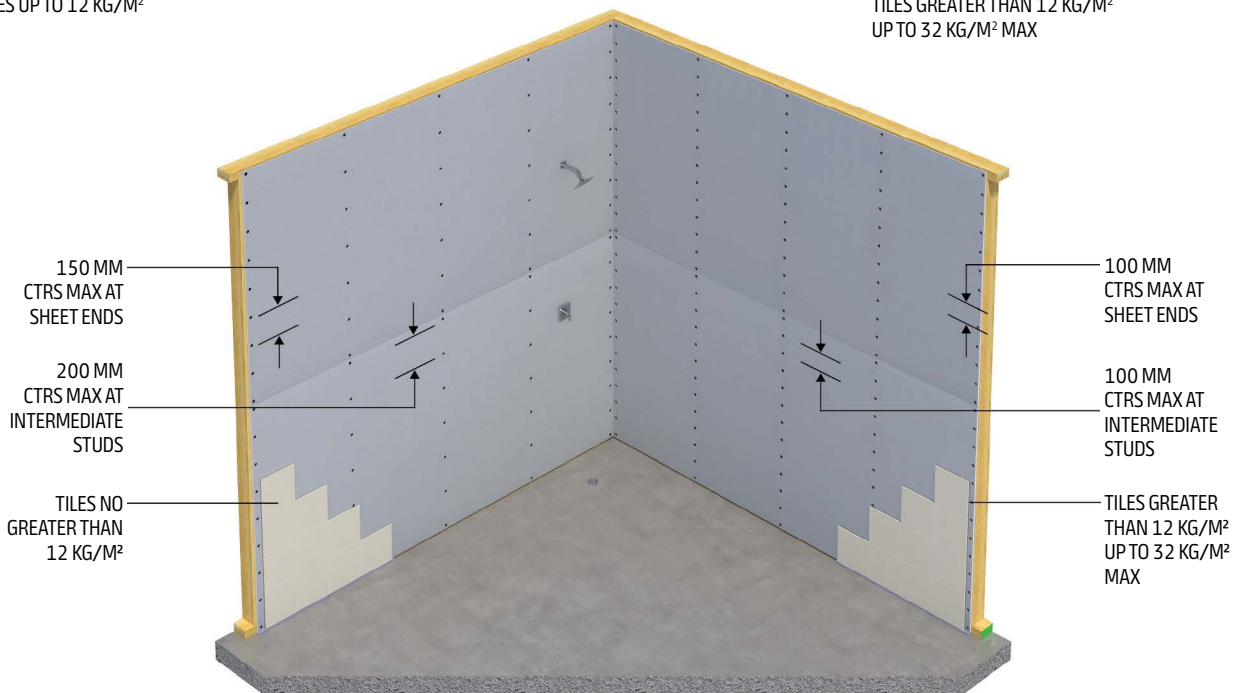

WET AREAS *CONT.*

Waterproofing of Wet Areas

Figure 52: Waterproofing of Enclosed Shower Over Bath

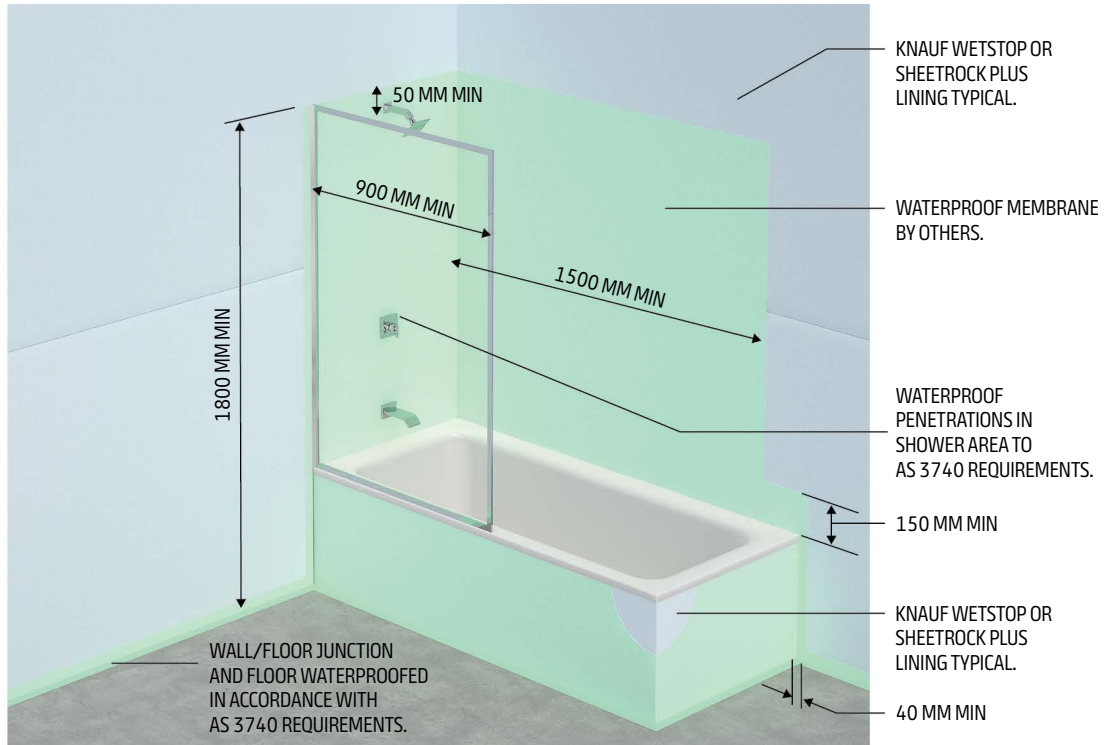
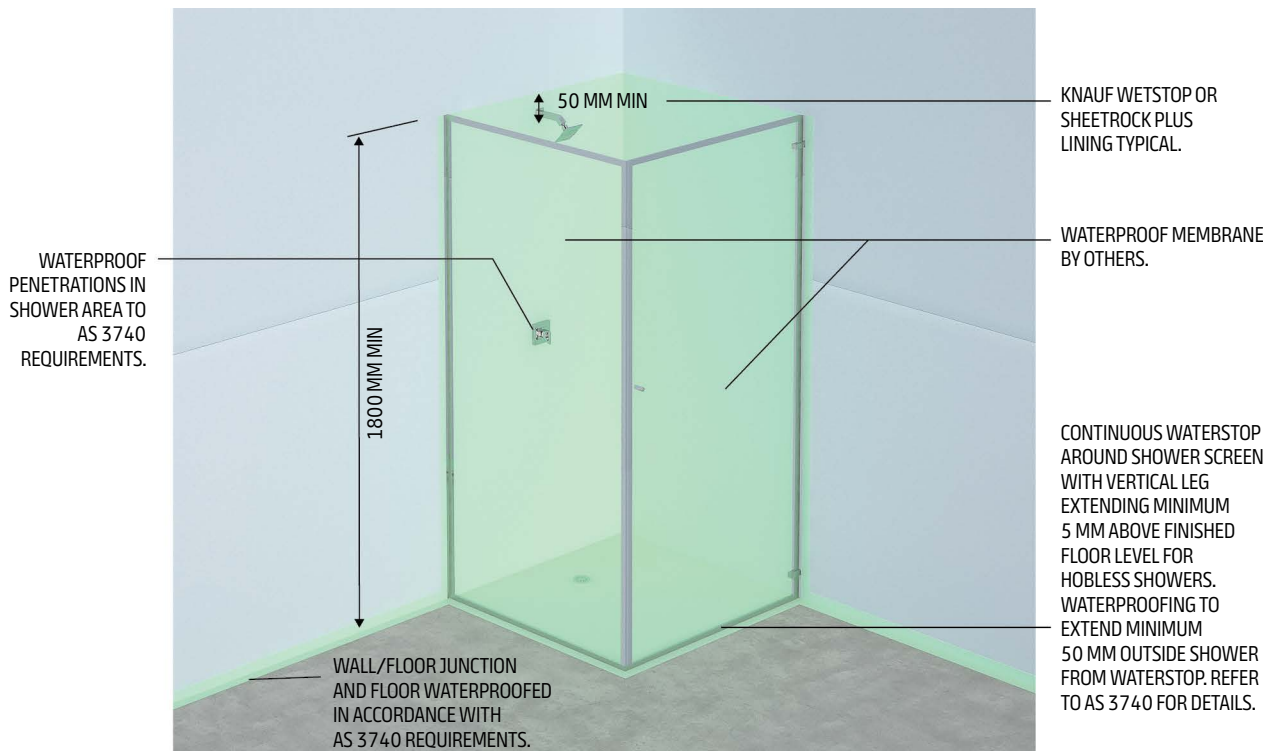

Figure 53: Waterproofing of Enclosed Shower Without Hob



WET AREAS *CONT.*

Figure 54: Waterproofing of Unenclosed Shower Over Bath

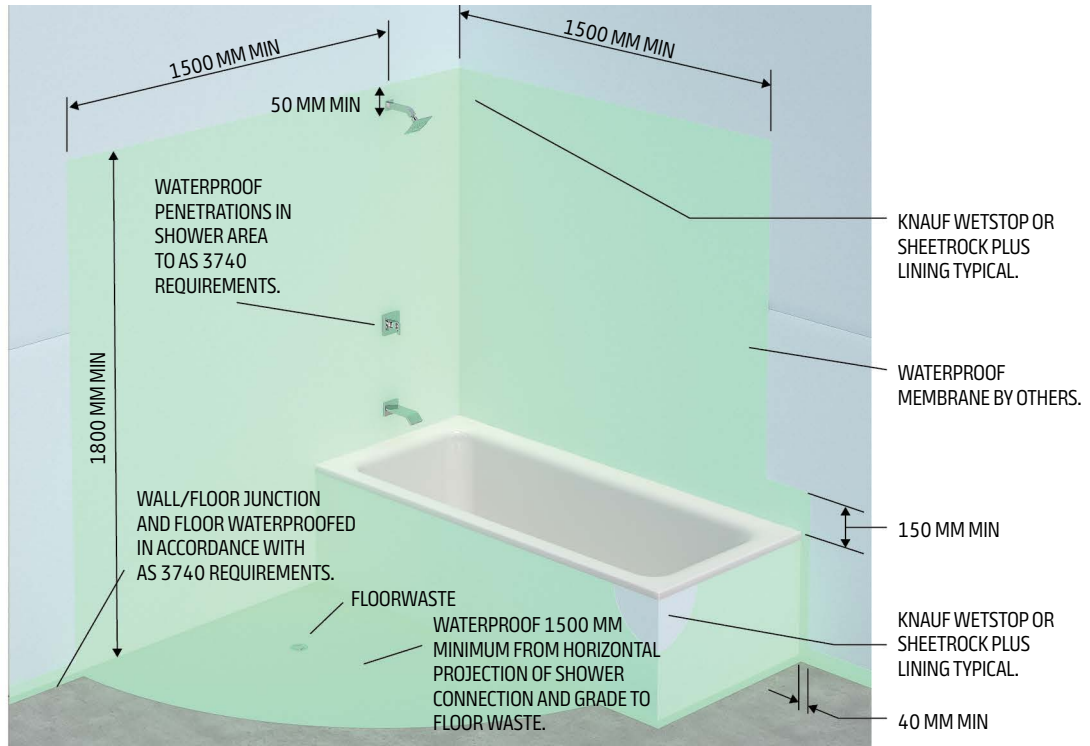
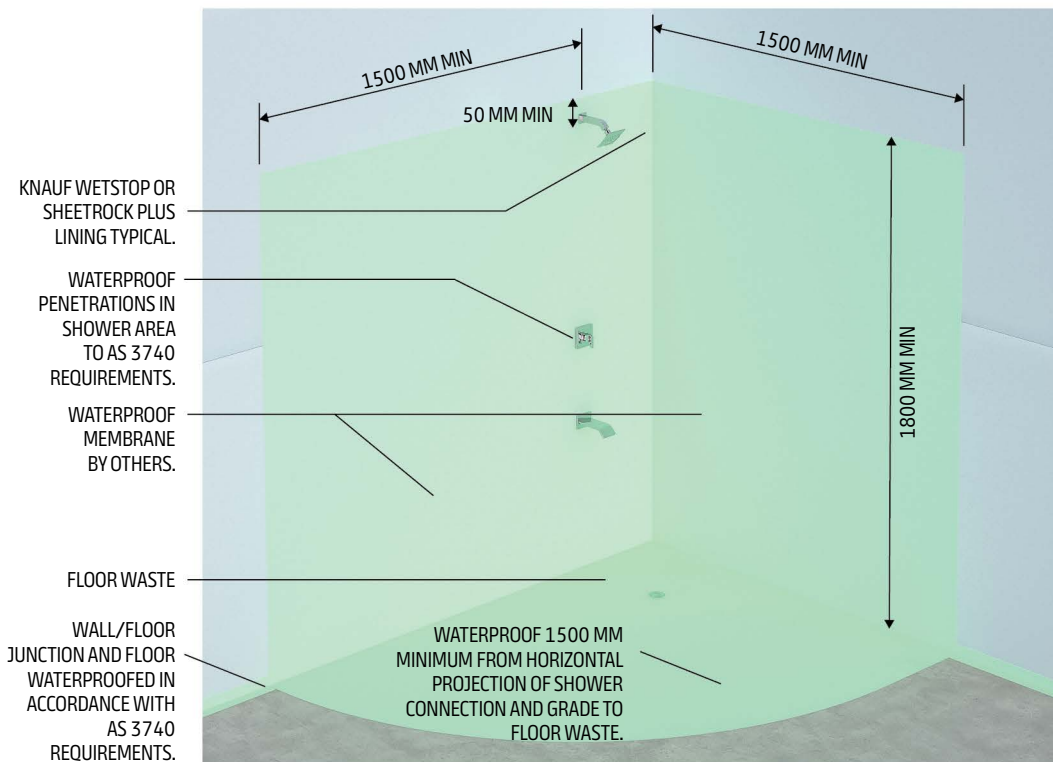

Figure 55: Waterproofing of Unenclosed Shower



WET AREAS *CONT.*

Figure 56: Waterproofing of Bath

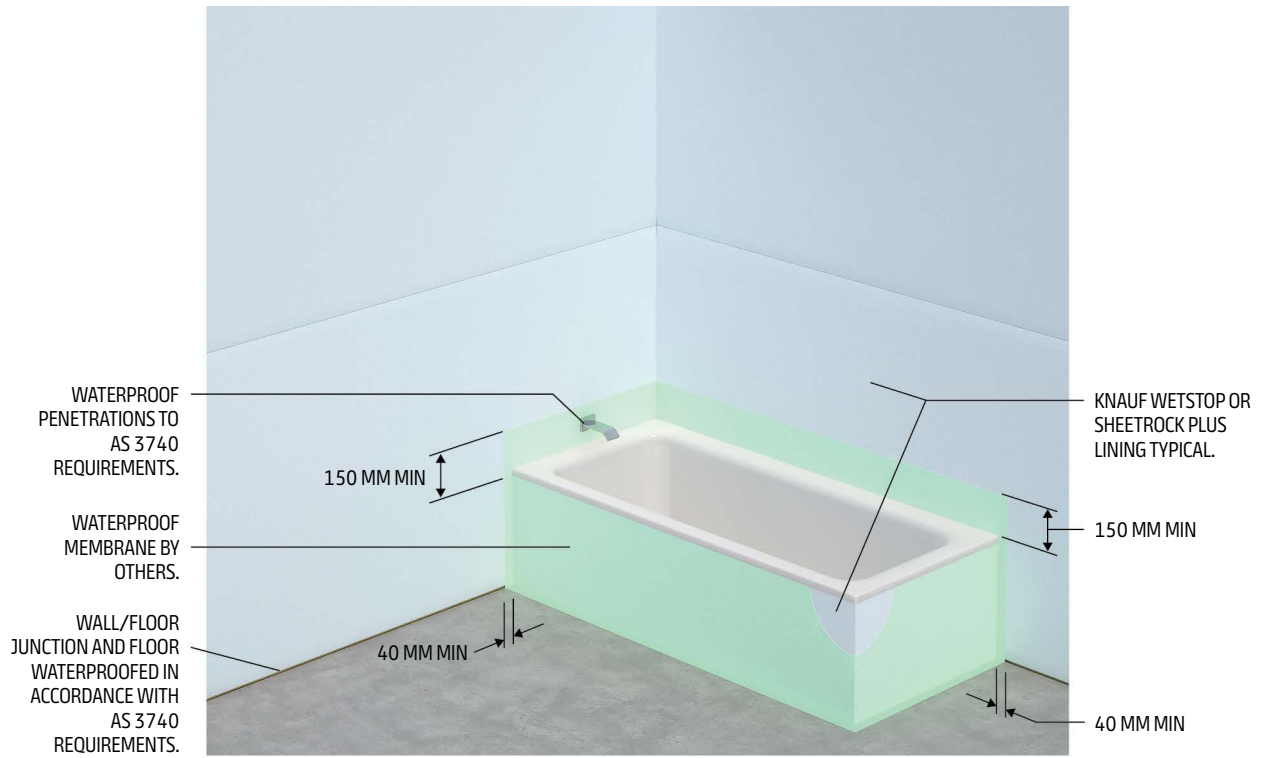
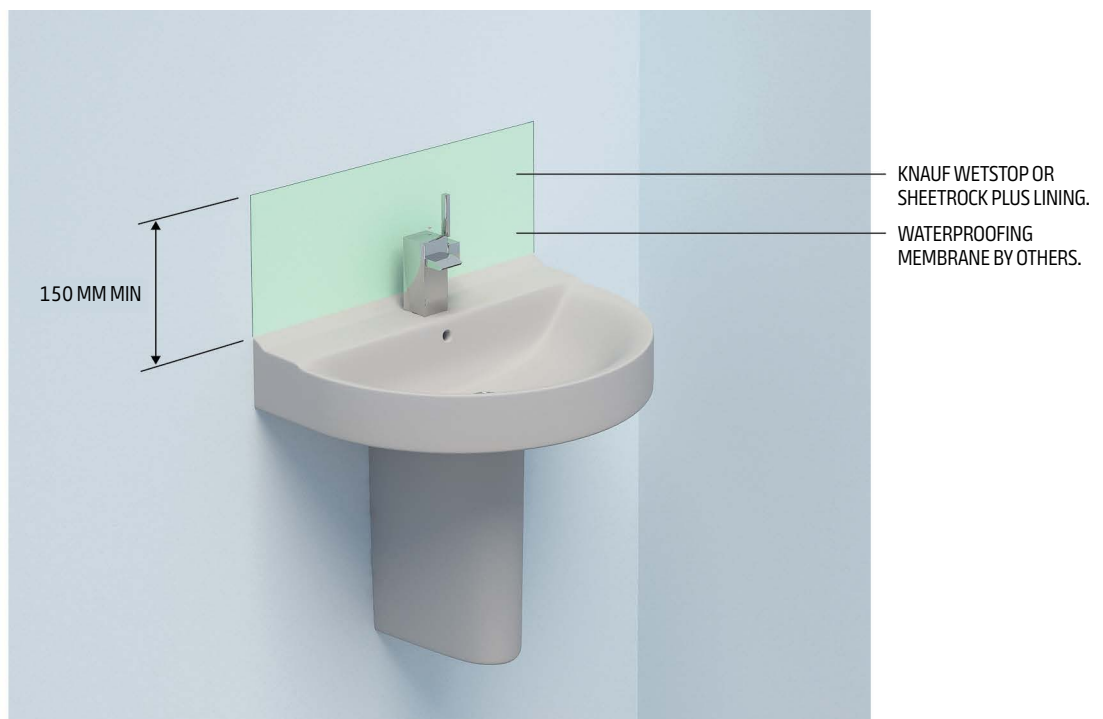

Figure 57: Waterproofing of Basin



WET AREAS CONT.

Waterproofing of Joints and Junctions

Joints and junctions within wet areas must be waterproofed prior to installation of tiling or other approved surface materials.

Cut edges of gypsum linings at wall-floor junctions, preformed shower bases and over bath lip must be protected by sealing with flexible waterproof sealant.

Waterproofing Wall Junctions

Waterproof sheet edges above baths, shower bases, laundry tubs, etc by sealing with flexible waterproof sealant for the full depth of the board.

Waterproof floor and wall junctions by sealing with flexible waterproof sealant for the full depth of the board.

Jointing in Wet Areas

Knauf water resistant gypsum linings in wet areas must be jointed using Knauf base compounds and paper tape (refer to Jointing section for application details).

Notes

No finishing compound is required where walls are to be tiled.

Waterproofing of Penetrations

Use hole saw to make penetrations for taps, shower nozzles and the like. Waterproof cut edges of gypsum linings at penetrations by sealing with flexible waterproof sealant for the full depth of the board (refer Figure 66). Alternatively, plumbing penetrations can be waterproofed with proprietary waterproofing components.

Cover fastener heads with a skim coat of Knauf base compound.

Installation Details

To view the full range of Wet Area installation details, scan QR code below or head to **knauf.com**.

- Preformed Shower Tray - Timber or Steel Studs
- Insitu/Vinyl Shower - Timber or Steel Studs
- Insitu Shower Step - Timber or Steel Studs
- Bath Installation - Timber or Steel Studs
- Bath Void Installation - Timber or Steel Studs
- Shower Over Bath - Timber or Steel Studs
- Corners - Timber or Steel Studs
- Shower Niches - Timber or Steel Studs
- Plasterboard Fixing Details
- FIBEROCK Fixing Details
- Jointing In Tiled Areas
- Non-Fire Rated Penetrations - Timber or Steel Studs



WET AREAS CONT.

Do

Knauf water resistant lining materials must:

- Be fixed to framing only with mechanical fasteners when used as a substrate in tiled and wet areas. Stud adhesives must not be used in tiled or wet areas
- Be faced with ceramic tiles or other approved water resistant materials when installed in wet areas
- Only be applied to timber or steel framing or to a base layer of Knauf water resistant lining material, never to other types of lining materials; Multiple layers of Knauf water resistant lining materials must be fastened to framing individually
- Be jointed with paper tape.

Don't

Knauf water resistant lining materials must not:

- Be installed over a waterproof membrane
- Be used in high exposure areas such as group shower rooms, steam rooms or enclosed pool areas, or in areas of high humidity (above 90% RH)
- Be used in unprotected external applications
- Be used if fractured or damaged.

Figure 58: Finished Bathroom



CURVES AND ARCHES

Curves and arches can be constructed using Knauf SHEETROCK, or for tight radii curves, 6.5 mm Flexiboard plasterboard.

Constructing Curved Walls and Ceilings

The minimum bending radii for some Knauf plasterboard products are as follows:

Table 30: Bending Radii

| Plasterboard Type and Thickness | Minimum bending radius for plasterboard fixed horizontally |
|---------------------------------|--|
| 6.5 mm Flexiboard | 650 mm – concave 450 mm – convex |
| 10 mm SHEETROCK ONE | 1700 mm |
| 13 mm SHEETROCK ONE | 2000 mm |

Shorter radii can be achieved by moistening the compressed face of plasterboard. When wetting the board, apply a small amount of clean water with a paint roller or sponge. Allow the water to soak for 15 minutes before attempting to bend the board. To prevent flat areas between the studs, space framing closer together than normal.

Notes

- Screw fasteners are preferable to nails to minimise possible impact damage.
- Avoid butt joints occurring in the curved section of the wall by using plasterboard sheets of suitable length.
- Make sure the sheet edge (or end) is correctly aligned to framing before driving fasteners.
- Ensure the board is in close contact with framing when fasteners are driven.
- To ensure a smooth curve, fasten in the field of board only where necessary.
- Fasten only to studs, not to top or bottom plates.

Refer to relevant Knauf publication for detailed instructions on fixing of Flexiboard plasterboard.

Arches

Interior wall arches, framed in timber or steel, can be lined with SHEETROCK plasterboard and the arch angles reinforced with Rondo Arch Bead P10.

Straight corners below the arch line should be finished with standard corner bead, (Rondo P32 or P01). Archway templates from min 12 mm thick particleboard or MDF cut to the required profile must be in place before the installation of plasterboard sheets.

Installation

- Fix plasterboard sheets, horizontally, to studs on one side of the wall as per standard installation instructions
- Screw/nail fix to templates and around the edge of the arch at maximum 300 mm centres or use stud adhesive
- Keep fasteners 10 mm min from the edge of the arch
- Do not place butt joints over or within 200 mm of the arch
- Allowing a 10 mm projection beyond the template, accurately mark the profile of the arch on the back of the sheet
- Cut out neatly with a keyhole saw
- Fix sheets on the other side of the wall
- From the cut side, square the line of cut across to the uncut sheet, mark the curve and cut out neatly as before
- Cut a strip of plasterboard to fit into the arch soffit, allowing enough length to reach 50 mm below the springing line on both sides of the arch
- Apply continuous beads of cornice adhesive to the back edges of the wall sheets around the arch
- If the arch has a tight radius, dampen the soffit strip to assist bending
- Fasten one end of the soffit strip 50 mm below the springing line and bed the strip into the cornice adhesive, progressively working around the arch
- Check that the soffit strip is installed neatly and tightly throughout the arch and fix the free end
- Cut plasterboard strips for the sides of the archway and fix using stud adhesive or fasteners
- Bend Rondo Arch Bead into position around the arch with the short leg on the face of the wall. Allow a minimum of 150 mm projection below the springing line at each end
- Fix one end of the arch bead at the springing line, then fix around the remaining arch at maximum 300 mm centres
- Fit standard external corner beads (Rondo P32 or P01) to the straight sides of the archway and fix at maximum 300 mm centres
- Joint and finish as per standard methods

CURVES AND ARCHES CONT.

Figure 59: Arch Construction

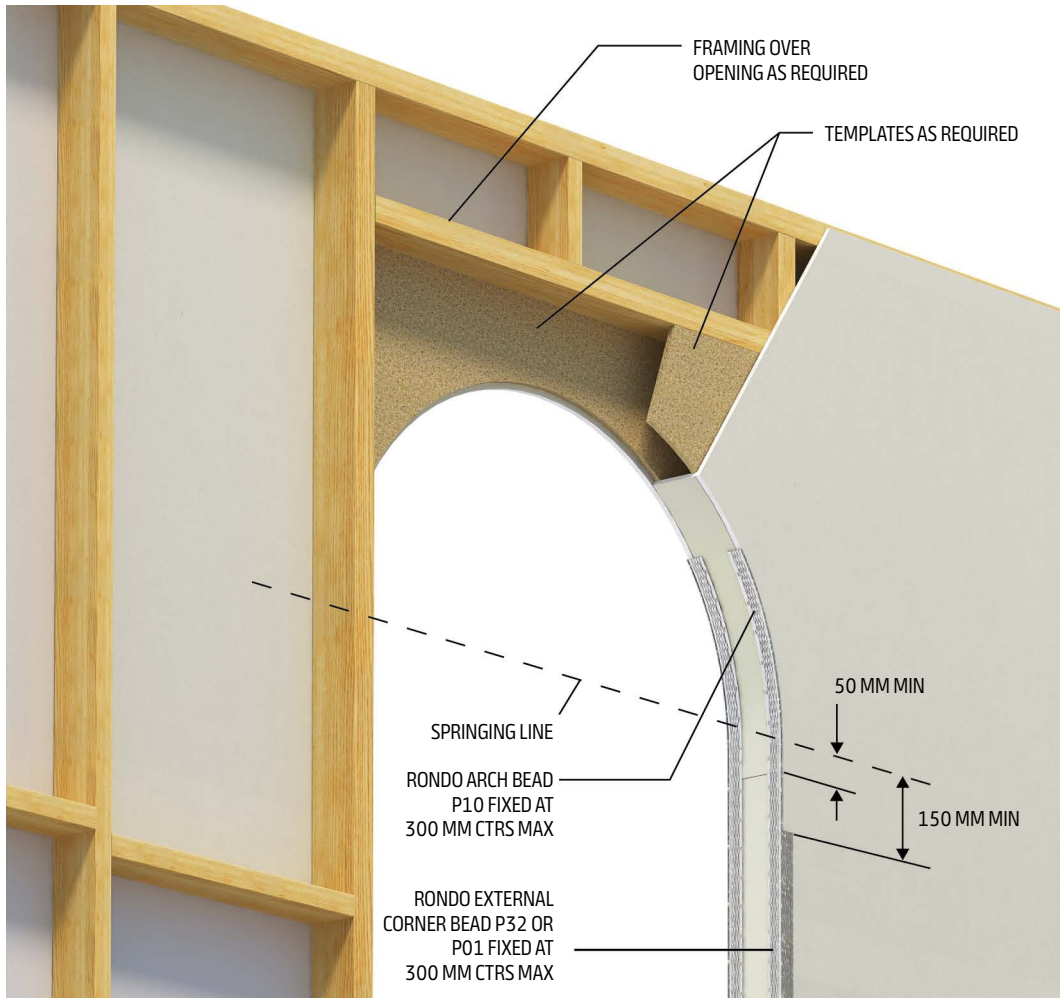

Figure 60: Rondo External Corner P01

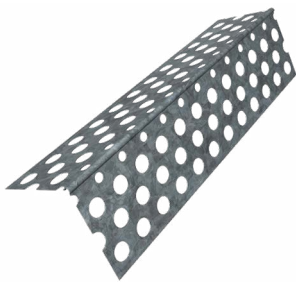

Figure 61: Rondo External Corner P32

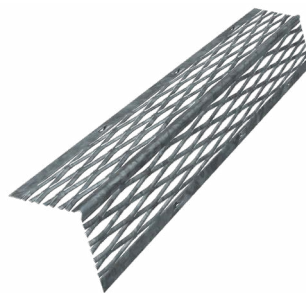
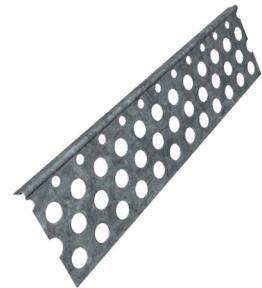

Figure 62: Rondo Arch Bead P10



CORNICES

Knauf SHEETROCK Cove & Decorative Cornices

Figure 63a: Knauf SHEETROCK Cove Range



Cove (90 mm)



Cove (55 mm)



Cove (75 mm)

Figure 63b: Knauf Decorative Cornice Range



Cairo 3 step (75 mm)



Manly (75 mm)



New York (90 mm)



Sydney (90 mm)

CORNICES CONT.

The installation specifications provided below are applicable to Knauf paper faced cornices.

Handling and Layout

- Ensure cornices are stacked neatly away from traffic areas to protect profile and prevent damage
- Cornice should be carried and handled 'on edge' to avoid cracking the core or wrinkling the paper liner
- Where possible use full lengths of cornice and mitre all corner and butt joints
- Ensure accurate and level placement by marking ceiling and walls with a line at the cornice edge
- Install shorter lengths of cornice first then fit longer lengths by bowing out to spring mitres into place

Cutting Cornice

- Measure, mark and cut cornice with a mitre cut each end, using a fine-tooth saw and a mitre box
- Cut internal angles from the long point, and external angles from the short point
- Check each cut piece of cornice for actual fit
- Measure and precut cornice to length before mixing the cornice adhesive

Figure 64: Cutting Cornices using a Mitre Box

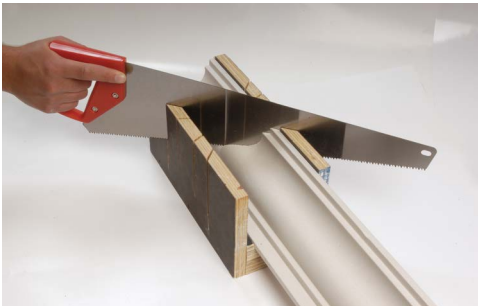

Position A



Position C



Position B



Position D

Figure 65: Finished Cornice

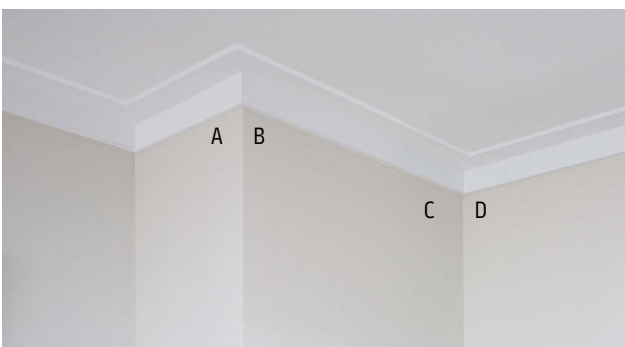
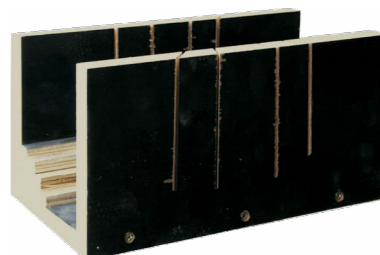

Figure 66: Cornice Mitre Box



CORNICES CONT.

Fixing Cornice

- Fix cornice to plasterboard walls and ceilings using Knauf Cornice Adhesive with nails as temporary support for at least 20 minutes
- If cornice is fixed to fibre cement linings, thoroughly wet the fibre cement at cornice line to prevent premature Cornice Adhesive dry-out and cracking at bottom edge
- Apply 10 mm minimum bead of Cornice Adhesive to top and bottom cornice edges
- All mitres and joints to be buttered with Cornice Adhesive
- Fibrous plaster cornice must be thoroughly dampened along mitres prior to the application of Cornice Adhesive
- Large cast cornices and ceiling roses may require mechanical or other supplementary fixing. Refer to manufacturers recommendations
- Painted surfaces require scoring or abrading, or both, to provide an adequate key prior to the application of Cornice Adhesive and cornice
- Cornice must be mechanically fixed around cupboards and onto timber beams
- Avoid use on hot, windy days where there is a high risk of early dry-out; to reduce early dry-out, wet sponging/dampening of the plasterboard surfaces and the use of Knauf Cornice Adhesive 45 is recommended
- Refer to Garage and External Ceilings for additional installation requirements in these areas
- When adhering cornice to masonry wall, apply Cornice Adhesive to the back of cornice so that it does not squeeze out under the bottom edge

Mixing Cornice Adhesive

- Always use clean, cold potable water and clean containers and tools for mixing. Using dirty containers/water/tools may affect the working time and set strength
- The inclusion of other materials to a mix will impair the performance (e.g. reduced strength and poor adhesion) and void the product warranty
- Mix only enough compound for stated working time when using setting compounds
- Always add Knauf Cornice Adhesive powder to water and mix to a usable paste
- Avoid overmixing as this may accelerate setting

Figure 67: Sydney Cornice

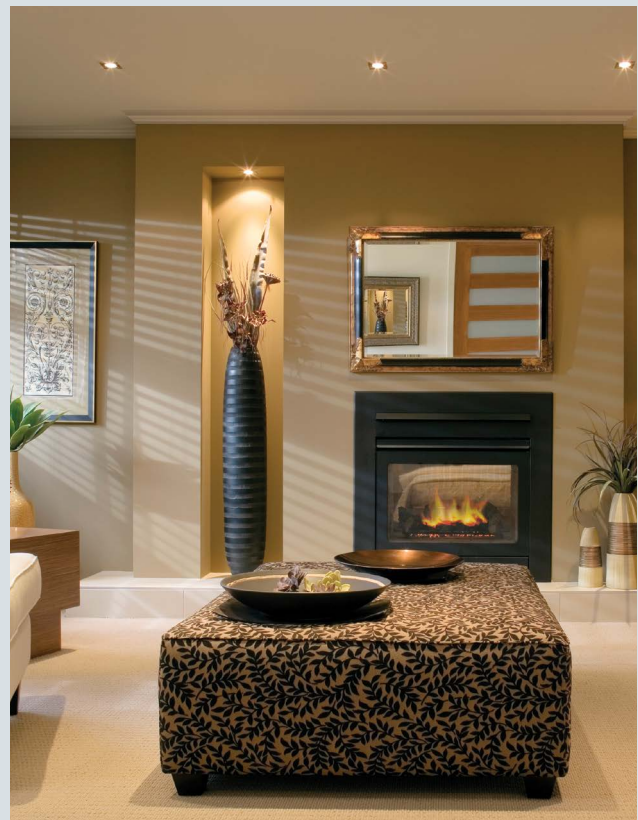

JOINTING

General

Jointing and finishing of plasterboard should be carried out according to the required level of finish.

If no level is specified then Level 4 is the default level of finish for domestic construction. It requires all joints and external angles to be taped and coated as follows:

- Apply a first coat and taping of compound. This step involves, the first coat of compound, bedding the tape and then a skim coat over the tape
- Apply a second coat of compound to fill and level joints
- Apply a finishing coat of compound.

The joint compound should be finished smooth and be free of tool marks and ridges.

Extreme care must be taken in jointing and finishing where walls or ceilings are subject to critical lighting (refer to Glancing Light sections and to Knauf publication Guide to Lighting and Decoration of Plasterboard).

Internal corners are to be completed with a two-coat system. A first coat and taping compound, followed by a finishing coat compound.

External corners are to be completed with a three-coat system but paper tape is not required. First a perforated metal angle is attached and then apply a first and second coat compound, followed by a finishing coat compound.

Notes

- *A finishing coat is not required in tiled areas, including tiled wet areas. Joints only require a bedding and second coat of Knauf base and bedding compound. Paper tape is required in wet area applications.*
- *External corners in tiled applications to have a 6 mm gap filled with flexible sealant in lieu of the standard jointing process. Refer to Knauf for details.*

Jointing Compounds

Types of Jointing Compounds

Jointing compounds broadly fall into two types: setting compounds and air-drying compounds. The jointing system may consist of one or both types of compounds and jointing tape. They can be applied with hand and mechanical tools.

Setting Compounds

Setting compounds are plaster-based and are used for first coat and taping. They are also usually used for the second coat. They can be applied with either hand or mechanical tools and generally provide a stronger joint than air-drying compounds. Knauf paper tape must be used when taping with setting compounds.

Air-Drying Compounds

Air-drying compounds are vinyl-based premixed compounds that can be used for first coat and taping, second coat and the finishing coat. They can be applied with either hand or mechanical tools. Knauf paper tape must be used when taping with a suitable air-drying compounds. Check which air-drying compound is suitable for taping in the table below.

On hot, windy days, where the risk of early dry out exists, the use of air-drying type compound, suitable for first coat and taping is recommended.

Air-drying compounds need at least 24 hours to dry thoroughly (longer in cold, wet weather conditions).

Air-drying compounds should not be applied when the interior temperature is less than 10°C.

Application of plaster-based setting compounds over premixed air-drying compounds is not recommended as this may affect joint performance.

Storage

Compounds should be stored under cover in a dry environment, out of direct sunlight, above ground and protected from the elements and temperature extremes.

Storage in an unsuitable environment, or once the pail or bag is opened, can shorten the life of this product.

It is recommended to be used before the best before date displayed on the pail or bag.

JOINTING CONT.

Mixing Compounds

To achieve the best results when working with jointing compounds, here are key recommendations to follow and common mistakes to avoid:

Recommendations

- Check the 'best before' date on packaging to ensure compounds are fit for use
- Always use clean, cold potable containers and tools for mixing
- Slowly add powder to water and allow powder to soak before mixing
- Mix only enough compounds for stated working time when using setting compounds
- Mix by hand or with a power mixer (max of 400 RPM – mixing at higher speeds may draw air into the mix, creating air bubbles). Mix until a smooth workable paste has been achieved
- If liquid has separated from the compound, stir carefully to restore consistency
- Product may appear thick in pail. Before adding water, lightly mix and test its application; if required, add water to achieve desired consistency
- On hot, windy days, where the risk of early dry out exists, the use of air-drying type compound, suitable for first coat and taping is recommended

Avoid

- Avoid using dirty containers/water/tools as this may affect the setting time and set strength
- Do not overmix product, as this may reduce working time
- Once setting has commenced the material cannot be remixed and must be discarded
- The inclusion of other materials to a mix will impair the performance (e.g. reduced strength and poor adhesion) and void the product warranty
- Avoid overmixing setting compounds as this may accelerate setting and shorten the working time of the compound
- Do not apply over joints that are not thoroughly dry; pinholes may result
- Avoid over-thinning when adding water as this may cause cracking and excessive shrinkage
- When diluting, do not vigorously over mix as this will introduce entrapped air which can result in surface imperfections
- Do not mix with residues of previously used compounds.

JOINTING CONT.

| | | BEDDING & BASE | | | ALL PURPOSE | |
|-----------------|---------------------------|--|---|---|--|--|
| | |  BaseCote™ 45 BaseCote™ 60 BaseCote™ 90 |  Uniflott™ (5) |  RediBase™ |  All Purpose Premix |  Total Joint Finish |
| JOINTING | 1st Coat | √ ⁽³⁾ | √ ⁽⁵⁾ | √ ⁽³⁾ | √ ⁽³⁾ | √ ⁽³⁾ |
| | 2nd coat | √ | - | √ | √ | √ |
| | Finishing Coat | - | - | - | √ | √ |
| | External Angles | √ | - | √ | √ ⁽⁴⁾ | √ ⁽⁴⁾ |
| | Mechanical Tools | √ | - | √ | √ | √ |
| SYSTEMS | Fire Rated ⁽¹⁾ | √ | - | √ | √ | √ |
| | Wet Area | √ ⁽²⁾ | - | - | √ ⁽⁷⁾ | √ ⁽⁷⁾ |
| | Curing Type | Setting | Setting | Air-Drying | Air-Drying | Air-Drying |
| | Working Times | 45, 60 or 90 mins | 45 mins | - | - | - |
| | Product Size | 20 kg bag 10 kg available for BC45 | 5 kg bag | 18 kg pail | 18 kg pail | 12 kg pail, 4.8 kg pail, 2 kg pail |
| | Packs /Pallet Quantity | 56 (20 kg) 91 (10 kg) | 200 | 48 | 48 | 64 (12 kg), 144 (4.8 kg), 245 (2 kg) |
| | Scrape Back | Easy to scrape | - | Very easy to scrape | Very easy to scrape | Very easy to scrape |
| | Sanding | - | - | - | Moderate | Moderate |
| | | | | | 150 - 180 grit | 150 - 180 grit |
| | Compound Type | Powder | Powder | Ready Mix | Ready Mix | Ready Mix |
| | Colour | Off-White | White | Off-White | White | White |

This technical information is intended to provide general information on plasterboard products and should not be used as a substitute for professional building advice. We recommend you use a qualified person to install Knauf plasterboard. To ensure the information you are using is current, Knauf recommends you review the latest building information available on the Knauf website knauf.com

Notes

- 1. Fire Rated** - Paper tape must be used in fire-rated applications.
- 2. Wet Area** - Knauf setting type bedding and base compounds can be used if a waterproofing membrane is installed by a specialist contractor and complying with the requirements of AS4858 Wet Area Membranes is applied over the whole face of Wet Area walls. Paper tape must be used in wet area applications.
- 3. Paper Tape** - Paper tape must be used with first coat compounds when jointing.
- 4. Air Drying/ Ready Mix Compounds** - Air Drying /Ready Mix Compounds are not recommended for embedding External Angles due to the extended drying time.
- 5. Stratopanel** - Uniflott is only for use in Stratopanel ceiling systems.
- 6. X Ray GIB X-Block** - Jointing Compound is specifically designed to give lead equivalent joints on walls and ceilings when using GIB X-Block Plasterboard. GIB X-Block Jointing Compound must be applied to all joints including inner layer joints of 2 or more layer systems. Paper tape must be used for jointing and at least 2 coats of GIB X-Block Jointing Compound should be applied to prevent penetration of X-Rays at joints. Joints can be finished with any of the Knauf premium finishing compounds. GIB X-Block Jointing Compound is an air-drying type compound so ensure each coat has thoroughly dried before applying the next coat.
- 7.** Only when used as a finishing coat.

JOINTING CONT.

| | | FINISHING COMPOUNDS | | | PATCHING | X-RAY |
|------------------------|---------------------------|---|---|---|---|---|
| | |  |  |  |  |  |
| | | SHEETROCK® Total LITE™ | LiteFinish™ | FinalCote™ | Patching Plaster | GIB X-Block® Jointing Compound⁽⁶⁾ |
| JOINTING | 1st Coat | - | - | - | - | √ ⁽⁶⁾ |
| | 2nd coat | √ | √ | - | - | √ |
| | Finishing Coat | √ | √ | √ | - | - |
| | External Angles | - | - | - | - | √ |
| | Mechanical Tools | √ | √ | √ | - | √ |
| SYSTEMS | Fire Rated ⁽¹⁾ | √ | √ | √ | - | √ |
| | Wet Area | √ ⁽⁷⁾ | √ ⁽⁷⁾ | √ | - | - |
| Curing Type | | Air-Drying | Air-Drying | Air-Drying | Setting | Air-Drying |
| Working Times | | - | - | - | 50 mins | - |
| Product Size | | 17.5 kg pail | 18 kg pail | 20 kg pail | 1.5 kg pail | 25 kg bag |
| Packs /Pallet Quantity | | 48 | 48 | 48 | 245 | 25 |
| Scrape Back | | - | - | - | Scrape while green | Easy to scrape |
| Sanding | | Very easy sanding | Very easy sanding | Easy sanding | Moderate | - |
| | | 180 - 220 grit | 180 - 220 grit | 180 grit | 150 - 180 grit | |
| Compound Type | | Ready Mix | Ready Mix | Ready Mix | Powder | Powder |
| Colour | | Yellow | Yellow | Off-White | Off-White | Brown |

This technical information is intended to provide general information on plasterboard products and should not be used as a substitute for professional building advice.

We recommend you use a qualified person to install Knauf plasterboard. To ensure the information you are using is current, Knauf recommends you review the latest building information available on the Knauf website knauf.com

Notes

- 1. Fire Rated** - Paper tape must be used in fire-rated applications.
- 2. Wet Area** - Knauf setting type bedding and base compounds can be used if a waterproofing membrane is installed by a specialist contractor and complying with the requirements of AS4858 Wet Area Membranes is applied over the whole face of Wet Area walls. Paper tape must be used in wet area applications.
- 3. Paper Tape** - Paper tape must be used with first coat compounds when jointing.
- 4. Air Drying/ Ready Mix Compounds** - Air Drying /Ready Mix Compounds are not recommended for embedding External Angles due to the extended drying time.
- 5. Stratopanel** - Uniflott is only for use in Stratopanel ceiling systems.
- 6. X Ray GIB X-Block** - Jointing Compound is specifically designed to give lead equivalent joints on walls and ceilings when using GIB X-Block Plasterboard. GIB X-Block Jointing Compound must be applied to all joints including inner layer joints of 2 or more layer systems. Paper tape must be used for jointing and at least 2 coats of GIB X-Block Jointing Compound should be applied to prevent penetration of X-Rays at joints. Joints can be finished with any of the Knauf premium finishing compounds. GIB X-Block Jointing Compound is an air-drying type compound so ensure each coat has thoroughly dried before applying the next coat.
- 7.** Only when used as a finishing coat.

JOINTING CONT.

Jointing Tapes

Jointing tapes are used to provide reinforcement to plasterboard joints and angles.

Knauf paper tape must be used for jointing of gypsum wall and ceiling linings due to its high strength and suitable for all setting and air-drying type jointing compounds and applications.

Knauf paper tape must be used in wet area and fire-rated applications.

Notes

As the two sides of paper tape are not identical, the outside of the roll should always be applied to the wet plaster compound to ensure the best adhesion.

Tools and Accessories

A wide range of plastering tools and accessories is available* through Knauf Fulfilment Centres or distributors, including:

- Power tools
- Fasteners
- Joint knives
- Sanding tools
- Trowels
- Mechanical jointing tools
- Plasterers trestles and scaffolding.

Notes

** Check product availability with your local Knauf Fulfilment Centre and Knauf stockist.*

Stainless steel jointing tools are recommended for the best possible finish and service longevity. Low-cost plastic tools are also available and may be suitable where low cost or disposable tools are required.

Tools should be cleaned in water before compounds have fully

set and stainless steel tools given a light rub with an oiled cloth to prevent rusting.

Plasterers trestles or scaffolding should be used to ensure correct working height.

Jointing with Hand Tools

Recessed Joints

Recessed Joints should be jointed and finished with a three-coat system using paper tape.

Before each coat, surfaces must be clean and free from dust. Thoroughly clean all tools and equipment after use.

First Coat and Taping

- Fill any gaps in joints with first coat compound prior to the taping process
- Fill recessed joint with a layer of first coat compound using a flexible 150 mm broad knife
- Centre and press the paper tape into the first coat compound using a 150 mm broad knife, drawing along the joint with sufficient pressure to remove excess compound
- Ensure all air bubbles have been expelled, taking care sufficient compound is left under the tape to provide a strong bond
- After bedding the tape, apply a skim coat of compound to fill the recess

Second Coat

- Allow sufficient time for each coat of compound to set thoroughly before applying the next coat. Air-drying compounds need at least 24 hours to dry thoroughly (longer in cold, wet weather conditions)
- Scrape to remove any rough spots or lumps
- Apply a second coat of compound approx. 200 mm wide, using a trowel or broad knife
- Use a straight or curved trowel on the finishing coat to produce a slight convex curve. Feather out the edges

Finishing Coat

- Ensure the second coat has dried thoroughly (24 hours)
- Scrape to remove any rough spots or lumps
- Using a trowel, apply a coat of finishing compound approx 250 mm wide, feathering out approx 25 mm beyond edges of the basecoat
- Use a straight or curved trowel on the finishing coat to produce a slight convex curve. Feather out the edges
- Air-drying compounds need at least 24 hours to dry thoroughly (longer in cold, wet weather conditions)
- When thoroughly dry, lightly sand to a smooth finish with sanding mesh or 150-220 grit paper, depending on sanding hardness of finishing compound used
- Do not use sandpaper lower than 150 grit. Take care to avoid scratching when sanding

JOINTING CONT.

Figure 68: Stopping Recessed Joints



1. First coat – Bedding compound



2. First coat – Bed tape

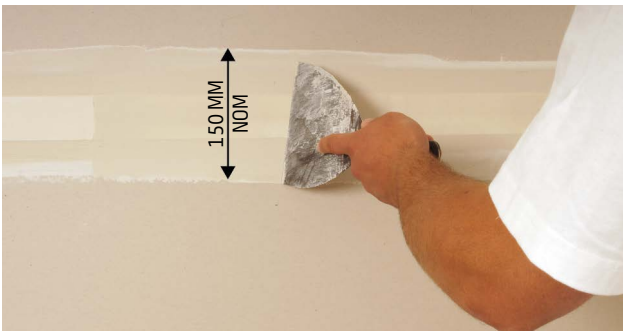

3. First coat – Skim coat

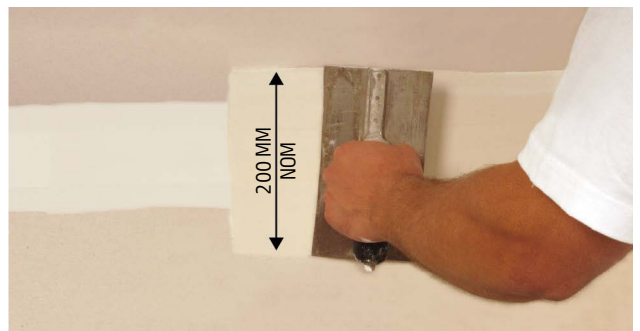

4. Second coat

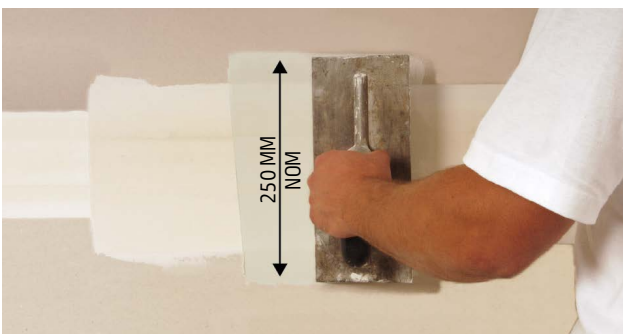

5. Finishing coat



6. Dry sanding

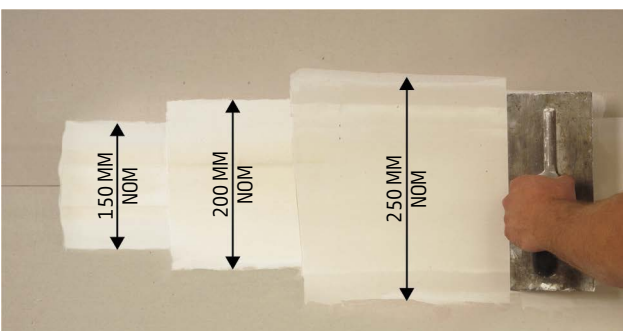

7. Total recessed joint system

JOINTING CONT.

Butt Joints

Butt, or end, joints should be jointed and finished with a three coat system using paper tape.

For a flatter finish, and to minimise surface build-up of compound, widen each jointing coat so that the final coat of the finished joint is about 500 mm wide.

Before each coat, surfaces must be clean and free from dust. Thoroughly clean all tools and equipment after use.

First Coat and Taping

- Fill in any gaps in joints with first coat compound prior to the taping process
- Using a trowel, apply a thin layer of first coat compound to each side of the joint (approx 300 mm total width) prefilling any recess gaps at the joints
- Centre and press the paper tape into the first coat compound using a 150 mm broad knife, drawing along the joint with sufficient pressure to remove excess compound
- Ensure all air bubbles have been expelled, taking care sufficient compound is left under the tape to provide a strong bond
- After bedding the tape, apply a skim coat of compound

Second Coat

- Allow sufficient time for each coat of compound to set thoroughly before applying the next coat. Air-drying compounds need at least 24 hours to dry thoroughly (longer in cold, wet weather conditions)
- Scrape to remove any rough spots or lumps
- Apply a second coat of compound to each side of the joint (approx 400 mm total width)
- Use a straight or curved trowel on the finishing coat to produce a slight convex curve. Feather out the edges

Finishing Coat

- Ensure the second coat has dried thoroughly (24 hours)
- Scrape to remove any rough spots or lumps
- Using a trowel, apply a coat of finishing compound approx 500 mm wide feathering out approx 75 mm beyond the edges of the second coat
- Use a straight or curved trowel on the finishing coat to produce a slight convex curve. Feather out the edges
- Air-drying compounds need at least 24 hours to dry thoroughly (longer in cold, wet weather conditions)
- When thoroughly dry, lightly sand to a smooth finish with sanding mesh or 150–220 grit paper, depending on sanding hardness of finishing compound used
- Do not use sandpaper lower than 150 grit. Take care to avoid scratching when sanding

Figure 69: Stopping Butt Joints

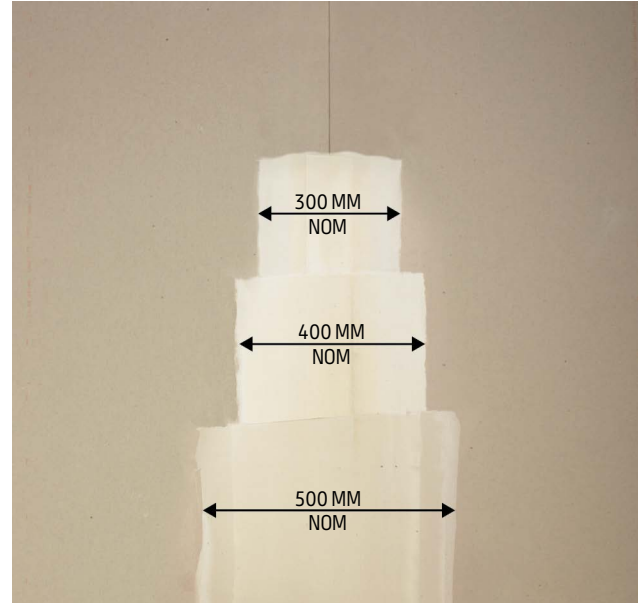

Fastener Heads

- Fastener heads should be spotted with each successive coat of jointing compound applied in different direction and extending 25 mm beyond the previous coat
- When the finishing coat is dry, lightly sand to a smooth finish using 150–220 grit sand paper, depending on sanding hardness of finishing compound

JOINTING CONT.

Internal Corners

Internal corners should be jointed and finished with a two coat system using paper tape. Gaps in excess of 3 mm should be pre-filled with a first coat compound.

Before each coat, surfaces must be clean and free from dust. Thoroughly clean all tools and equipment after use.

Installation

- Fill any gaps in joints with first coat compound prior to the taping process
- Apply first coat compound to both sides of internal corner using a 75 mm broad knife or glazing tool
- Measure and cut reinforcing tape, fold along centreline and bed into corner, using a 50 mm corner taping tool or 75 mm glazing tool
- After bedding the tape, apply a skim coat of compound to fill the recess

Second Coat

- Allow sufficient time for each coat of compound to set thoroughly before applying the next coat. Air-drying compounds need at least 24 hours to dry thoroughly (longer in cold, wet weather conditions)
- Scrape to remove any rough spots or lumps
- Apply a second coat of finishing compound, using a broad knife, then finish with a 100 mm corner finishing tool or 75 mm glazing tool, feathering beyond edges of first coat

Finishing Coat

- Air-drying compounds need at least 24 hours to dry thoroughly (longer in cold, wet weather conditions)
- When thoroughly dry, lightly sand to a smooth finish with sanding mesh or 150-220 grit paper, depending on sanding hardness of finishing compound used
- Do not use sandpaper lower than 150 grit. Take care to avoid scratching when sanding

Figure 70: Stopping Internal Corners



1. Apply base compound



2. Bed tape



3. Apply second coat

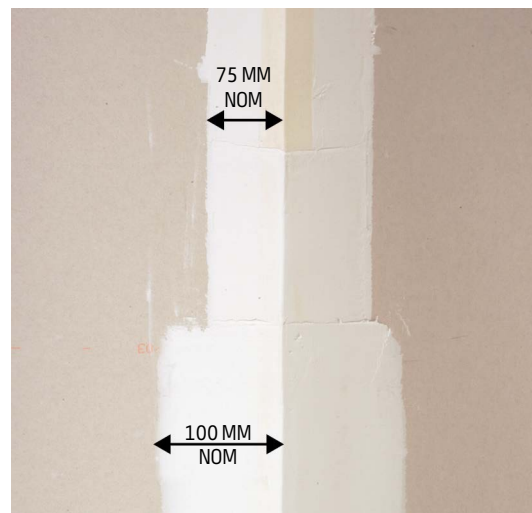

4. Internal corner jointing system

JOINTING CONT.

External Corners

External corners should be strengthened with perforated metal angles then jointed and finished with a three coat system.

No paper tape is required. Before each coat, surfaces must be clean and free from dust. Thoroughly clean all tools and equipment after use.

Suitable metal angles include Rondo Corner Beads P01 or P32.

Installation

- Cut metal angle to length and position so that the angle is both straight and in line with the wall surfaces. Ensure that there is a 10 mm gap left at the concrete floor to avoid rust
- Fix with nails or staples at maximum 300 mm centres along each face with nails opposite each other
- Ensure that the first coat of compound covers approx. 150 mm of angle faces and is forced through the perforations

Second Coat

- Allow sufficient time for each coat of compound to set thoroughly before applying the next coat. Air-drying compounds need at least 24 hours to dry thoroughly (longer in cold, wet weather conditions)
- Scrape to remove any rough spots or lumps
- The second coat should extend approx. 200 mm from the corner

Finishing Coat

- Ensure the second coat has dried thoroughly (24 hours)
- Scrape to remove any rough spots or lumps
- The finishing coat should extend approx. 280 mm from the corner with the edges feathered out approx. 50 mm beyond the edges of the second coat
- Ensure that the finished coat is built up to the corner
- Air-drying compounds need at least 24 hours to dry thoroughly (longer in cold, wet weather conditions)
- When thoroughly dry, lightly sand to a smooth finish with sanding mesh or 150-220 grit paper, depending on sanding hardness of finishing compound used
- Do not use sandpaper lower than 150 grit. Take care to avoid scratching when sanding.
- Other beads and angles (Shadowline, Stopping Angle, etc) should be finished in the same manner

Figure 71: Stopping External Corners



1. Cut angle and fix to sides of corner at 300 mm ctrs



2. Apply first coat to both corner faces

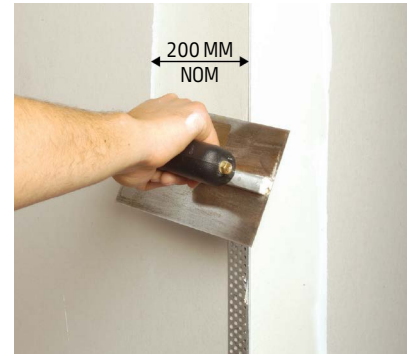

3. Apply second coat to corner faces



4. Apply third coat to corner faces

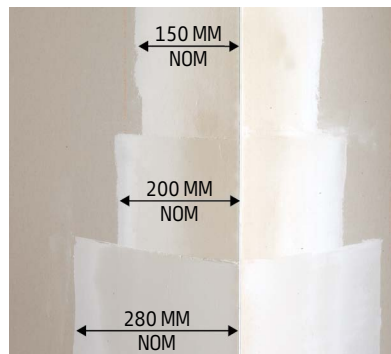

5. External corner jointing system

JOINTING CONT.

Jointing with Mechanical Tools

Mechanical jointing tools have been widely adopted in the plastering industry due to their versatility and speed of application.

The most common types of mechanical jointing tools are:

- Taping Machines (i.e. Banjo Box, Mud Box)
- Flat Finishing Boxes (200 mm, 250 mm, 300 mm)
- Corner boxes and heads.

All Knauf base and finishing compounds are suitable for use with mechanical tools.

Recessed Joints

Recessed Joints should be jointed and finished with a three-coat system using paper tape. Before each coat, surfaces must be clean and free from dust. Thoroughly clean all tools and equipment after use.

First Coat and Taping

- Load the jointing tape and first coat compound into the taping machine in accordance with manufacturer's instructions
- Adjust the taping machine to achieve minimum 1 mm compound thickness under the tape
- Apply the tape in accordance with manufacturer's instructions
- Immediately fill recessed joint using and appropriate mechanical tool (i.e. Wallboard Tools MudShark) or 150 mm broad knife. Ensure full width of recess is filled

Notes

- *Filling the recess after the application of tape is critical in order to achieve a good bond and avoid compound dry-out (especially in hot, dry conditions). It also reduces the possibility of tape edge curling or wrinkling which may lead to edge cracking.*
- *On hot, windy days, where the risk of early dry out exists, the use of air-drying type compound, suitable for first coat and taping is recommended.*

- Allow sufficient time for each coat of compound to set thoroughly before applying the next coat. Air-drying compounds need at least 24 hours to dry thoroughly (longer in cold, wet weather conditions)
- Scrape to remove any rough spots or lumps
- Apply a second coat of compound using a 200 mm flat box
- Load the box with first coat compound in accordance with manufacturer's instructions
- Set the crown to required height using adjustable setting
- Coat the joint in accordance with manufacturer's instructions

Notes

- *When applying the second coat with a 200 mm box, avoid too much take off; if following through with a broad knife, this will ensure that joint is flat.*
- *Beware of creating hollow joints when following through with a broad knife. All topping compounds will shrink back if second coat is hollow.*
- *Ensure box setting cam is set correctly to compensate for any out of plane frame undulations (i.e. Uneven trusses or centre row wall noggings).*
- *Regularly change box blades and skid plates to avoid uneven joint finish.*

Finishing Coat

- Ensure the second coat has dried thoroughly (24 hours)
- Scrape to remove any rough spots or lumps
- Apply a finishing coat of compound using a 300 mm flat box
- Load the box with finishing coat compound in accordance with manufacturer's instructions
- Set the crown to required height using adjustable setting
- Coat the joint in accordance with manufacturer's instructions
- Air-drying compounds need at least 24 hours to dry thoroughly (longer in cold, wet weather conditions)
- When thoroughly dry, lightly sand to a smooth finish with sanding mesh or 150-220 grit paper, depending on sanding hardness of finishing compound used
- Do not use sandpaper lower than 150 grit. Take care to avoid scratching when sanding

Figure 72: Banjo Box Application



Figure 73: Flat Box Application



JOINTING CONT.

Butt Joints

- Butt, or end, joints should be jointed and finished using a three-coat system using paper tape
- Before each coat, surfaces must be clean and free from dust
- Thoroughly clean all tools and equipment after use
- Refer to Jointing with Hand Tools for coat widths
- Refer to Recessed Joints above for guidance on jointing using mechanical tools
- After bedding the tape, apply a skim coat of compound to reduce the possibility of tape edge curling or wrinkling
- Use appropriate flat boxes and broad knives to achieve required coat widths and build-up
- Air-drying compounds need at least 24 hours to dry thoroughly (longer in cold, wet weather conditions)
- When thoroughly dry, lightly sand to a smooth finish with sanding mesh or 150-220 grit paper, depending on sanding hardness of finishing compound used
- Do not use sandpaper lower than 150 grit. Take care to avoid scratching when sanding

Fastener Heads

- Fastener heads should be spotted with each successive coat of jointing compound applied in different direction and extending 25 mm beyond the previous coat
- When the finishing coat is dry, lightly sand to a smooth finish using 150-220 grit sand paper, depending on sanding hardness of finishing compound

Internal Corners

- Before each coat, surfaces must be clean and free from dust
- Thoroughly clean all tools and equipment after use
- Apply first coat compound and tape using a taping machine with a creaser OR apply first coat compound with a corner box and crease and bed tape by hand
- Skim coat and glaze using appropriate corner heads or glazing tools

- When dry, apply and glaze a coat of finishing compound using appropriate corner box or head
- Air-drying compounds need at least 24 hours to dry thoroughly (longer in cold, wet weather conditions)
- When thoroughly dry, lightly sand to a smooth finish with sanding mesh or 150-220 grit paper, depending on sanding hardness of finishing compound used
- Do not use sandpaper lower than 150 grit. Take care to avoid scratching when sanding

External Corners

- External corners should be strengthened with perforated metal angles and jointed with a three coat system
- Before each coat, surfaces must be clean and free from dust
- Thoroughly clean all tools and equipment after use
- Refer to *Jointing with Hand Tools* for application of perforated metal angle and coat widths
- Apply first coat compounds for first and second coats using appropriate mechanical tools in accordance with manufacturer's instructions
- Allow sufficient time for each coat of compound to set thoroughly before applying the next coat. Air-drying compounds need at least 24 hours to dry thoroughly (longer in cold, wet weather conditions)
- Apply the finishing coat using appropriate mechanical tools in accordance with manufacturer's instructions
- Air-drying compounds need at least 24 hours to dry thoroughly (longer in cold, wet weather conditions)
- When thoroughly dry, lightly sand to a smooth finish with sanding mesh or 150-220 grit paper, depending on sanding hardness of finishing compound used
- Do not use sandpaper lower than 150 grit. Take care to avoid scratching when sanding

DECORATING PLASTERBOARD LININGS

General Requirements

Knauf plasterboard linings are an excellent base for:

- Painting
- Wallpapering
- Special finishes.

When preparing and decorating plasterboard surfaces, ensure that only high quality paints, wallpapers etc are used and applied in accordance with the manufacturer's instructions.

If using semi-gloss or gloss paint, it is recommended that plasterboard surface is finished to a Level 5 standard as these paints tend to highlight surface variations.

Take care, when sanding and finishing joints and fastener heads, to avoid scuffing the plasterboard surface adjacent to the jointed areas.

Surface Preparation

- Make sure Knauf plasterboard linings are dry and free of dust, oil, or greasy stains before decorating surfaces. Correct visible surface variations with an approved filler

Painting

When painting plasterboard walls and ceilings, follow the procedures set down by the Australian Standard AS/NZS 2311 The painting of buildings.

It is recommended that a coat of quality sealer undercoat be applied to the plasterboard surface prior to the application of subsequent coats of paint. Sealer undercoat should be allowed to dry, lightly sanded and dusted down prior to the application of subsequent finish coats.

The chosen proprietary brand sealer undercoat should be formulated to fulfil the following functions:

- Equalise variations in porosity over the entire surface
- Stop the migration or bleeding of chemicals from the substrate which could affect the appearance of the finishing coat
- Conceal the difference in texture between the paper and the joints.

Notes

- Plasterboard linings should be sealed as soon as practical to minimise the risk of paper discolouration.
- Solvent borne sealers are recommended for plasterboard surfaces that may have discoloured due to prolonged exposure to ultraviolet light.
- Roller application of sealer and first coat of paint is recommended for best results.
- If plasterboard linings are painted using airless spray, all paint coats should be back rolled while wet. The lack of back rolling when painting by airless spray may result in excessive paper nap raising.
- Overthinning paint may cause banding.

Avoiding Glancing Light effects

When finishing Knauf plasterboard linings consider the effects of glancing light. Walls and ceilings that seem perfectly flat in diffused light may appear rough when lit by light falling across the wall or ceiling surface.

Avoid glancing light problems through careful planning of lighting and paint application at the design stage.

For more information, refer to the following publications:

- CSIRO, *Illumination and Decoration of Flat Surfaces*
- AWCI ANZ, *Glancing Light*
- Knauf, *Guide to Lighting and Decoration of Plasterboard.*

Figure 74: Glancing Light Situation



BUILDING THE FUTURE TOGETHER.

The Knauf Group is one of the world's leading manufacturers of modern insulation materials, dry lining systems, plasters and accessories, thermal insulation composite systems, floor screed, floor systems, and construction equipment and tools. With more than 300 production facilities and sales organisations in over 90 countries, 42,000 employees worldwide, and sales of €12.6 billion, the Knauf Group is one of the largest players in the industry, with operations in Europe, the United States (US), South America, Asia, Africa, and Australia.

The Knauf Group believes that the best innovations start with a purpose; a focus on why the innovation is needed and who will benefit from it. The business's focus is to deliver innovations that help companies in the construction sector to work smarter, do more, and build better. This is achieved through investing in purposeful innovation, expanding into different markets and constantly searching for new ways to increase performance and productivity. This commitment to innovation and focus on customers is inspired by a desire to empower architects, contractors, and workers alike to improve the way societies live by changing the way buildings are designed and built. Knauf is committed to delivering only the best to its customers and partners.





Sales Enquiries

1800 003 377

To purchase Knauf plasterboard and other building materials including insulation, cornice, compounds, ceilings and accessories visit the Where To Buy page on our website for a list of Knauf Fulfilment Centres and distributors.

TecASSIST

1800 811 222

Our National TecASSIST helpline is available to answer technical questions and provide free advice to builders, contractors, architects, engineers and home owners throughout Australia.

Technical Resources

knauf.com/en-AU/tools/download-center

Find all of Knauf's technical literature in our comprehensive Download Centre. From CAD files to certifications, installation guides and data sheets - our most up to date product and system information is at your fingertips.



knauf.com

©2025 Knauf Gypsum Pty Ltd. All rights reserved. The trademarks Knauf, Build on us, TecASSIST, eSelector, BIM WIZARD, WetStop, FireStop, ImpactStop, MultiStop, Shaftliner, Flexiboard, Uniflott, BaseCote, Total Lite, FinalCote, LiteFinish and PatchCote are trademarks of Knauf Gypsum Pty Ltd or one or more of its affiliates including Knauf Gips KG. SHEETROCK, FIBEROCK and Aqua-Tough are registered trademarks of United States Gypsum Company and used under license. All other trademarks identified with ® or ™ are owned by third party manufacturers and not Knauf Gypsum. Knauf Gypsum Pty Ltd. ABN 84 004 231 976. 3 Thackeray Street, Camellia NSW 2142, Australia.
29.09.2025_GYAU250818/08