

PROCESSING INSTRUCTIONS



## CONTENTS

- 1 GENERAL
- 2 INSPECTION OF THE DELIVERY
- 3 STORAGE, PROTECTION, AND ACCLIMATISATION
- 4 APPLICATION RANGE
- 5 TOLERANCES
- 6 WEIGHT OF BOARDS
- 7 MOUNTING PRINCIPLES
  - 7.1 MOUNTING MATERIALS
  - 7.2 MOUNTING POINTS
    - 7.2.1 DIRECTLY ON CONCRETE
    - 7.2.2 WOODEN LATTICEWORK / METAL CD PROFILES
  - 7.3 MOUNTING PATTERNS
    - 7.3.1 DIRECTLY TO CONCRETE WITH SCREWS
    - 7.3.2 DIRECTLY TO CONCRETE WITH ANCHORS
    - 7.3.3 WOODEN LATTICEWORK / METAL CD PROFILES
  - 7.4 ADAPTIVE FITTINGS
    - 7.4.1 MOUNTING TO CONCRETE
    - 7.4.2 WOODEN LATTICEWORK / METAL CD PROFILES
  - 7.5 FIRE-RESISTANT MOUNTING
    - 7.5.1 A2 BOARD (25MM - REI 60)
    - 7.5.2 TEKTALAN A2 (50MM - REI 180)
    - 7.5.3 TEKTALAN A2 (85-225MM - REI 180)
- 8 MOUNTING
  - 8.1 GENERAL INSTRUCTIONS
  - 8.2 HANDLING BOARDS
  - 8.3 MOUNTING DIRECTION
  - 8.4 SAW ADVICE
  - 8.5 SOLID BOARDS TO CONCRETE
  - 8.6 SOLID BOARDS ON WOODEN LATTICEWORK
  - 8.7 SOLID BOARDS TO METAL CD PROFILES
  - 8.8 SOLID BOARDS IN A GRID CEILING SYSTEM
- 9 PENETRATIONS
- 10 PAINTED BOARDS
- 11 PREVENTING MOISTURE SPOTS
- 12 MAINTENANCE / CLEANING
- 13 SPECIFIC KNOWLEDGE
- 14 FURTHER INFORMATION



## 1 GENERAL

The following applies to all our wood wool bound boards:

- All Heraklith® wood wool products have national and international certificates of quality. For product information, please visit our website [www.heraklith.hu](http://www.heraklith.hu).
- On the basis of the applicable Knauf Insulation General Terms and Conditions for Sales and Delivery, warranty is only provided on the wood wool boards and mounting materials supplied by Knauf Insulation if all the instructions given in these Processing Instructions have been strictly observed. This is to be demonstrated by the processor.
- Heraklith® wood wool boards are packed on pallets with protective corners. The relevant product information is provided on the label attached to each pallet.

## 2 INSPECTION OF THE DELIVERY

After unloading, the delivery note must be signed. It states the time of delivery, the number of products delivered and the quality of the delivery (visual inspection for signs of damage). Visible damage or other irregularities must be stated on the consignment note. If this is not done, any liability on the part of Knauf Insulation for transport damage will become null and void.

## 3 STORAGE, PROTECTION, AND ACCLIMATISATION

- Prior to use, the wood wool boards must be allowed to acclimatise for at least 48 hours in the room in which they will be mounted, at a temperature similar to that of the expected final ambient conditions.
- During acclimatisation, the packaging must be removed.
- The room in which the boards acclimatise must be protected from the direct effects of moisture, such as rainwater and leakage, at all times.

- Before use, store the boards horizontally, preferably on the pallet on which they were delivered, or at right angles on three wooden beams.
- When being used indoors, the boards should be mounted in a well-ventilated space. Do not use room heaters while mounting wood wool boards.

## 4 APPLICATION RANGE

Heraklith® boards are cement bound and are suitable for indoor and semi-outdoor use in, for example, covered car parks, the undersides of balconies and overhanging sections of buildings. Heraklith® boards may not be directly exposed to rainwater without surface treatment (hydrofobic primer and suitable paint). If you have any doubts about your intended use of the boards, please contact our Customer Service department.

## 5 TOLERANCES

All wood wool boards are manufactured in accordance with European standard EN 13168 and the stipulated tolerances. The specific tolerances may vary from one board to another. Please see the product data sheets of the board types concerned for more information. The product data sheets are available on our website: [www.heraklith.hu](http://www.heraklith.hu).

## 6 BOARD WEIGHTS

The weight of wood wool boards depends on the product type and thickness. The weights per square metre are stated on the product data sheets.

## 7 MOUNTING PRINCIPLES

### 7.1 MOUNTING MATERIALS

The Heraklith® range contains various mounting materials. When mounting directly onto standard density concrete (2000-2600 kg/m<sup>3</sup>), use anchors or concrete screws. When mounting either Tektalan A2 or Heraklith® boards in a fire-resistant manner, you should always use concrete screws. When mounting on wooden latticework or metal CD profiles, use Heraklith® wood screws or metal screws, respectively.

All mounting materials should be positioned according to the pattern for mounting points (paragraph 7.2) and the mounting patterns (paragraph 7.3) that match the specific board type.

#### Tip:

Check which drill bit diameter and length you will need for mounting your wood wool boards correctly. More information is available on the product data sheets for our mounting materials at [www.heraklith.hu](http://www.heraklith.hu).

#### Anchor fixing

The anchors are suitable for standard concrete with a density of 2000-2600 kg/m<sup>3</sup>. An SDS drill bit in a matching diameter should be used for drilling.

1. Drill through the predrilled board into the concrete using a hammer drill in accordance with the corresponding mounting pattern.
2. Remove the drill and install the mounting accessory. Push the anchor into the drilled hole through the board and set the drill to 'hammer'. 'Drive' the anchor into the concrete with the drill.
3. Place a structured cap over the anchor.

#### Concrete screw

The concrete screws are suitable for standard concrete with a density of 2000-2600 kg/m<sup>3</sup>. We recommend you use a standard drill bit with a diameter of 6 mm. Softer and/or older concrete types may require a smaller drilling diameter. That is why you should always test whether the screw will actually stay there when you use the indicated drill diameter.

1. Drill through the predrilled board into the concrete using a hammer drill in accordance with the corresponding mounting pattern.
2. Push the screw into the drilled hole through the board and screw it in using a cordless drill.

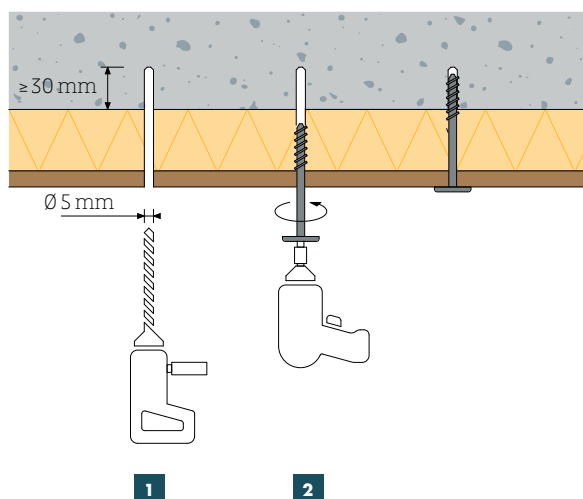
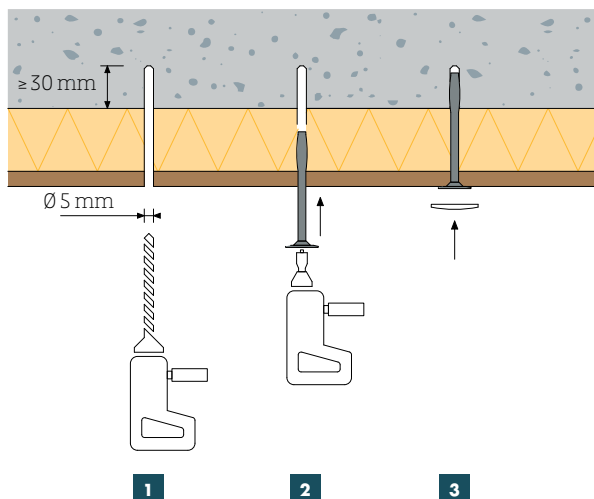

### Wood (compact) screw

Determine the centre-to-centre distance of the wooden latticework on top according to the mounting configuration recommended in paragraph 7.3.3. The minimum drilling depth should be the board thickness plus 25 mm.

We recommend using Heraklith® wood (compact) screws to mount boards onto wooden latticework. The flanged head will help stop the screws from overtightening when mounting the boards and prevent the boards from coming loose as a result of wind load. When using Heraklith® wood screws, the boards do not have to be predrilled.

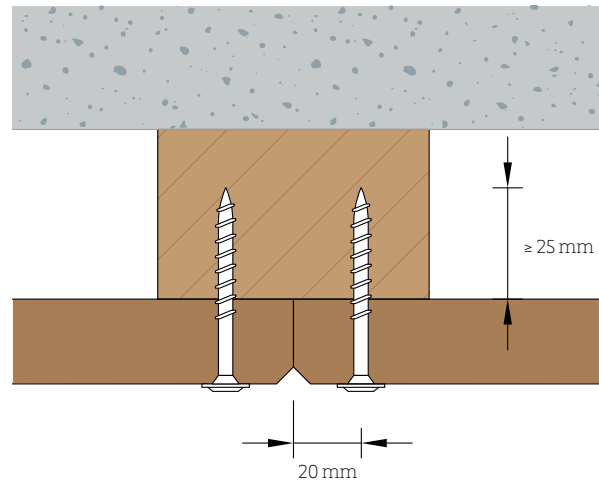

### Metal screw

Determine the centre-to-centre distance of the metal CD profiles on top according to the mounting configuration recommended in paragraph 7.3.3. The minimum drilling depth should be the board thickness plus 10 mm.

We recommend using Heraklith® metal screws to mount boards on metal CD profiles. The flanged head will help stop the screws from overtightening when mounting the boards and prevent the boards from coming loose as a result of wind load. When using Heraklith® metal screws, the boards do not have to be predrilled.

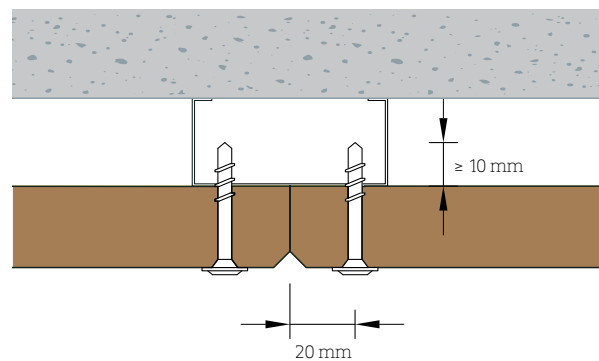

## 7.2 MOUNTING POINTS

The diagrams below show the mounting configurations recommended by Heraklith®. The different configurations are for mounting, subdivided by product type and, if applicable, different board sizes. All dimensions are given in millimetres.

### 7.2.1 DIRECTLY TO CONCRETE

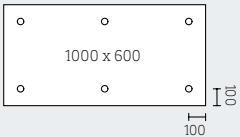
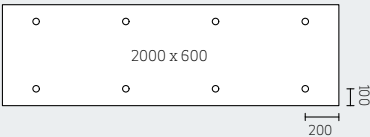
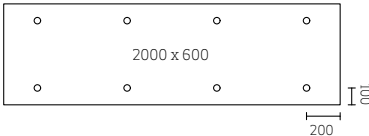
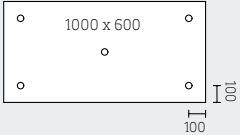
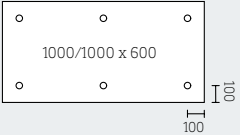
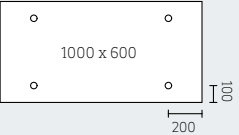
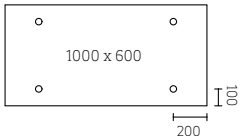
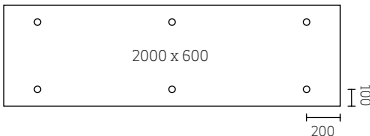
<p><b>A2 board</b></p>	<div style="display: flex; justify-content: space-around;"> <div style="text-align: center;"> <p>6 point mounting: <b>fire-resistant*</b></p>  <p>1000 x 600</p> </div> <div style="text-align: center;"> <p>8 point mounting</p>  <p>2000 x 600</p> </div> </div> <p>* Board thickness: 25 mm Underlying surface: Standard concrete (2000-2600 kg/m³) Mounting: Heraklith®   DDS plus concrete screw</p>
<p><b>Basic</b></p>	<div style="text-align: center;"> <p>8 point mounting</p>  <p>2000 x 600</p> </div> <p>Board thickness: 25 mm Underlying surface: Standard concrete (2000-2600 kg/m³) Mounting: Heraklith®   DDS plus concrete screw</p>
<p><b>Tektalan A2</b></p>	<div style="display: flex; justify-content: space-around;"> <div style="text-align: center;"> <p>5 point mounting: <b>fire-resistant*</b></p>  <p>1000 x 600</p> </div> <div style="text-align: center;"> <p>6 point mounting: <b>fire-resistant**</b></p>  <p>1000/1000 x 600</p> </div> <div style="text-align: center;"> <p>4 point mounting</p>  <p>1000 x 600</p> </div> </div> <p>* Board thickness: 50 mm Underlying surface: Standard concrete (2000-2600 kg/m³)</p> <p>** Board thickness: 75-150 mm Underlying surface: Standard concrete (2000-2600 kg/m³)</p>
<p><b>Heratekta</b></p>	<div style="display: flex; justify-content: space-around;"> <div style="text-align: center;"> <p>2 point*</p>  <p>1000 x 600</p> </div> <div style="text-align: center;"> <p>2 point**</p>  <p>2000 x 600</p> </div> </div> <p>* For indoor applications without wind load      ** For outdoor applications with wind load</p>

## 7.2.2. WOODEN LATTICEWORK / METAL CD PROFILES

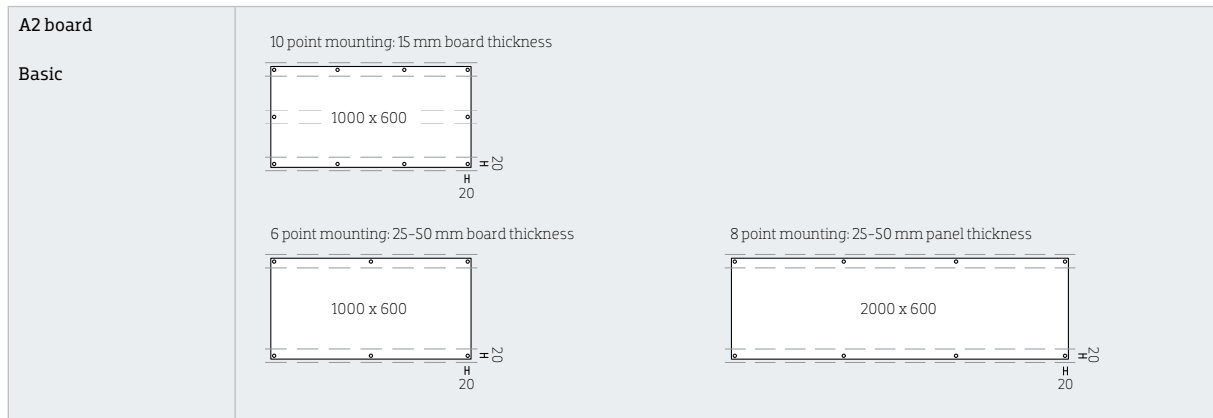

## 7.3 MOUNTING PATTERNS

The positioning and dimensioning of the different mounting patterns should be applied in combination with the mounting configurations given below. All dimensions are given in millimetres.

### 7.3.1 DIRECTLY TO CONCRETE WITH SCREWS

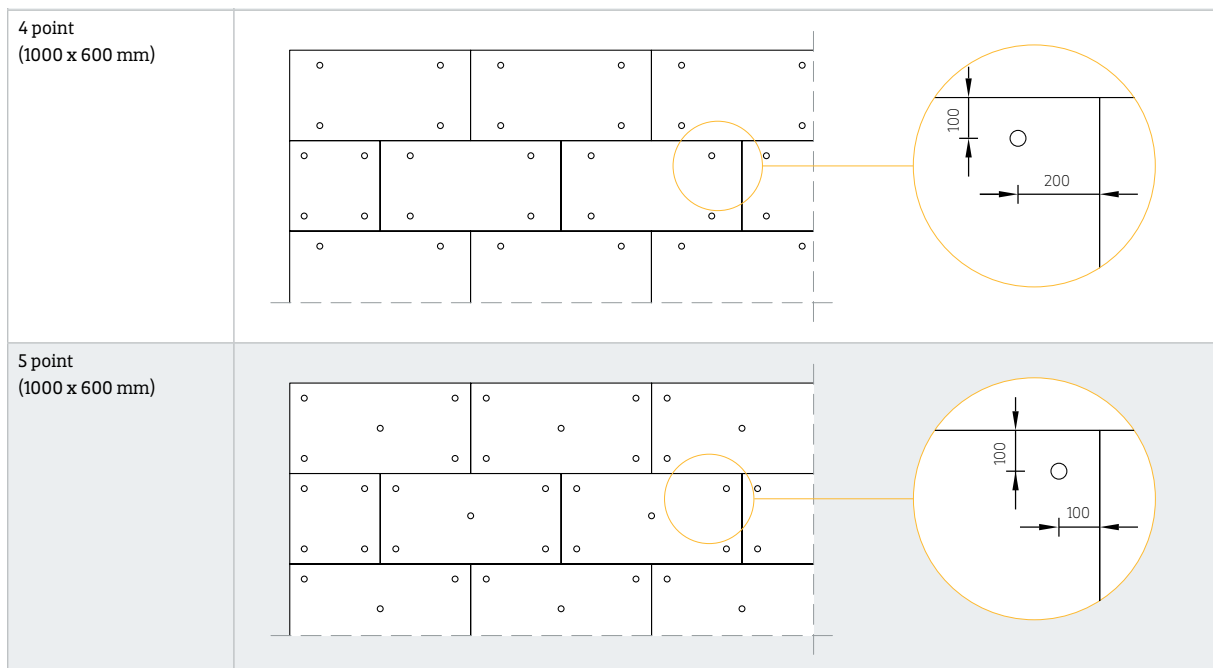

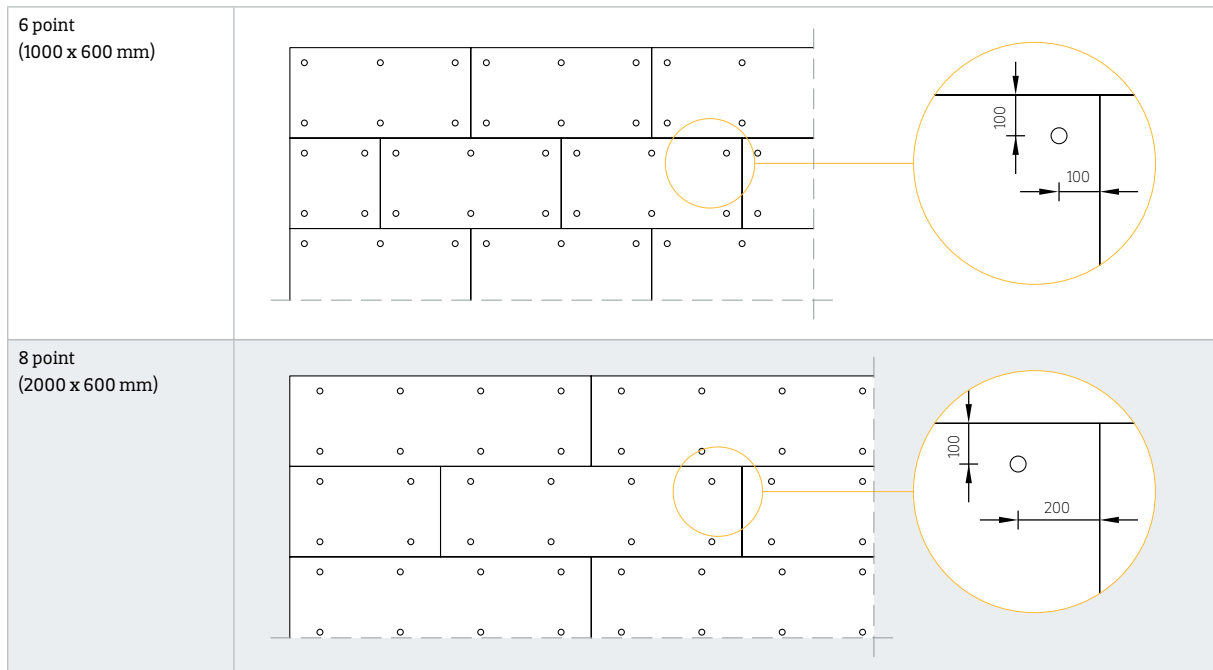

### 7.3.2 DIRECTLY TO CONCRETE WITH ANCHORS

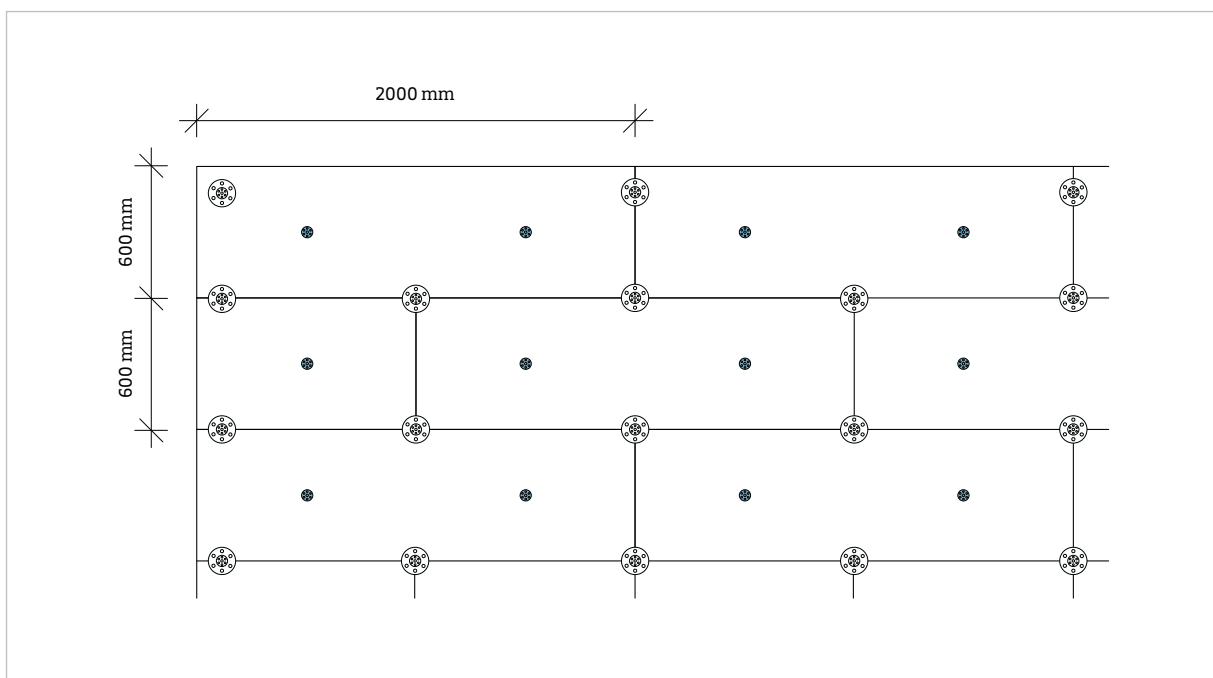

The anchors are placed at the corners of boards, i.e. one anchor can fix 3 boards.  
 Number of anchors in the middle of an area: 4 pc/board → 4 pc/m<sup>2</sup>, in average ca. 5 pc/m<sup>2</sup>. The Ø85 mm plates are not needed inside the boards (anchors marked with blue colour).

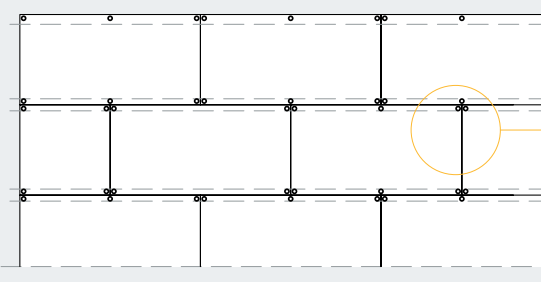
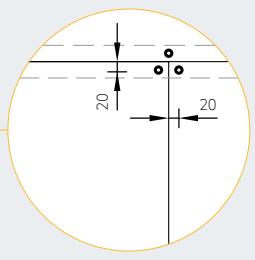
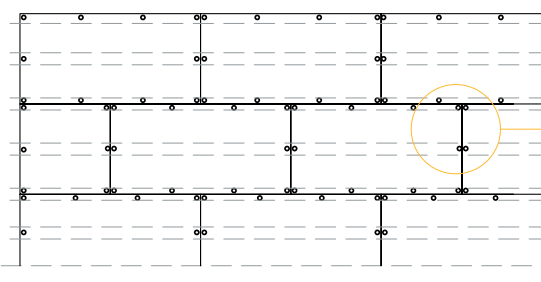
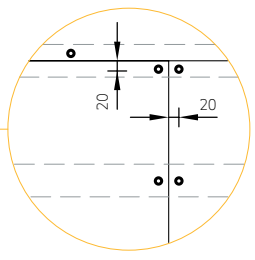
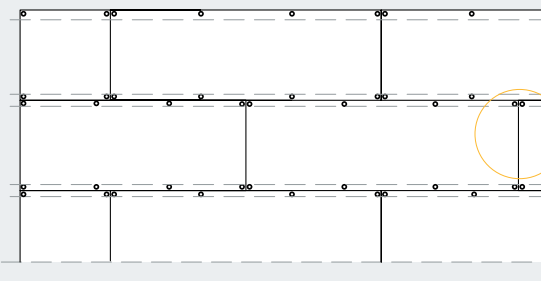
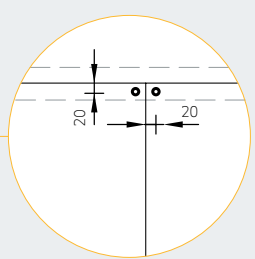

### 7.3.3 WOODEN LATTICEWORK / METAL CD PROFILES

<p>6 point (1000 x 600 mm)</p> <p>A2 board</p> <p>25-50 mm board thickness</p>		
<p>10 point (1200 x 600 mm)</p> <p>A2 board</p> <p>15 mm board thickness</p>		
<p>8 point (2000 x 600 mm)</p> <p>A2 board</p> <p>Basic</p> <p>25-50 mm board thickness</p>		

## 7.4 ADAPTIVE FITTINGS

### 7.4.1 MOUNTING TO CONCRETE

#### Attention!

Never use less than two fixings per adaptive fitting.

#### 8 point, 6 point and 5 point mounting

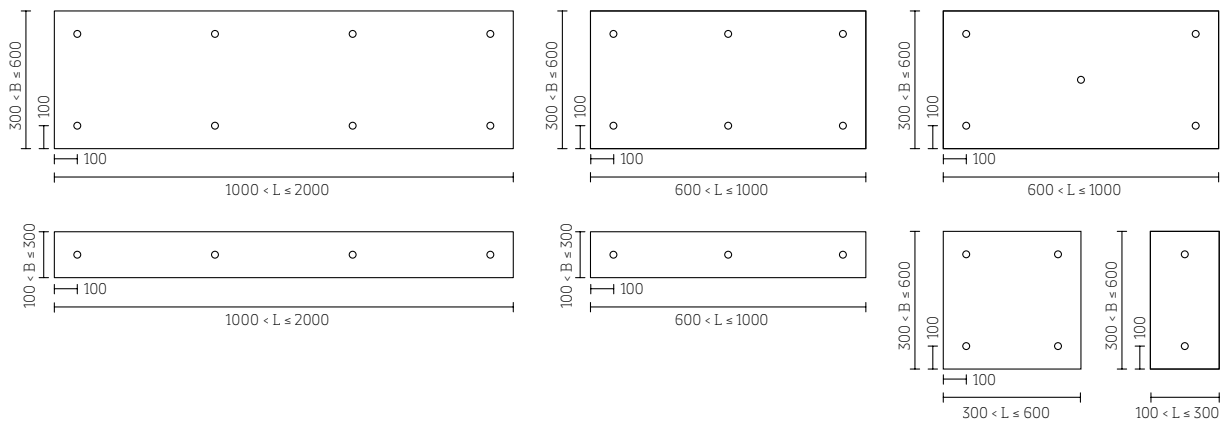

L = Length

B = Width

#### 6 point (600 x 2000 mm)

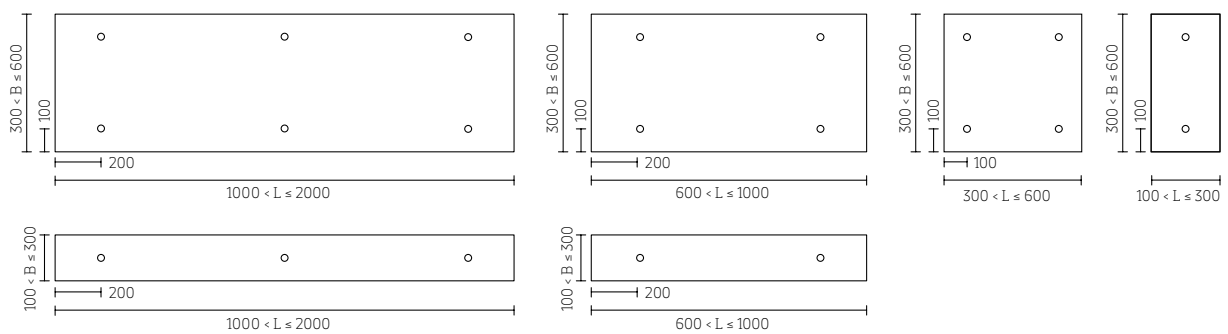

## 7.4.2 WOODEN LATTICEWORK / CD PROFILES

### 25-50 mm board thickness

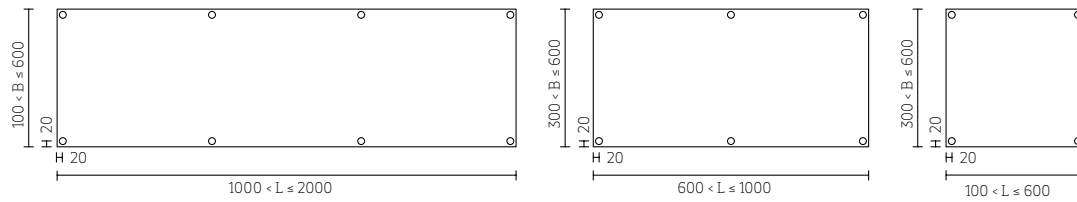

### 15 mm board thickness

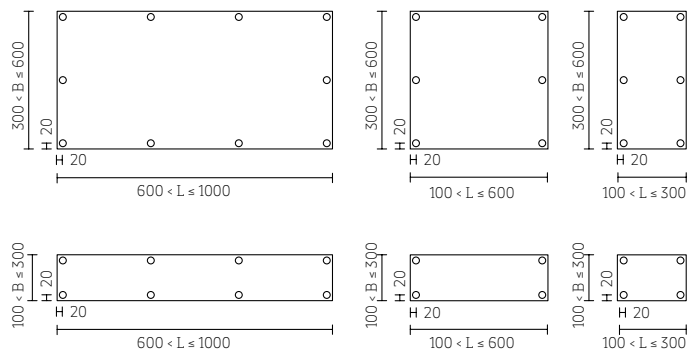

## 7.5 FIRE-RESISTANT MOUNTING

For fire-resistant applications, always use the mounting point positions and configurations given below. Also ensure that the respective mounting surface and materials are suitable for your requirements.

### 7.5.1 A2 BOARD (25 MM - REI 60)

#### Mounting surface

Solid concrete (2000-2600 kg/m<sup>3</sup>)

#### Suitable Heraklith® mounting materials

Heraklith® | Concrete screw

#### Applicable to

Heraklith® | A2 board

Board thickness: 25 mm

#### Fire-resistance

REI 60 [EN 1365-2 / EN 13501-2]

Report no.: 16211 [Warringtonfire, Gent]

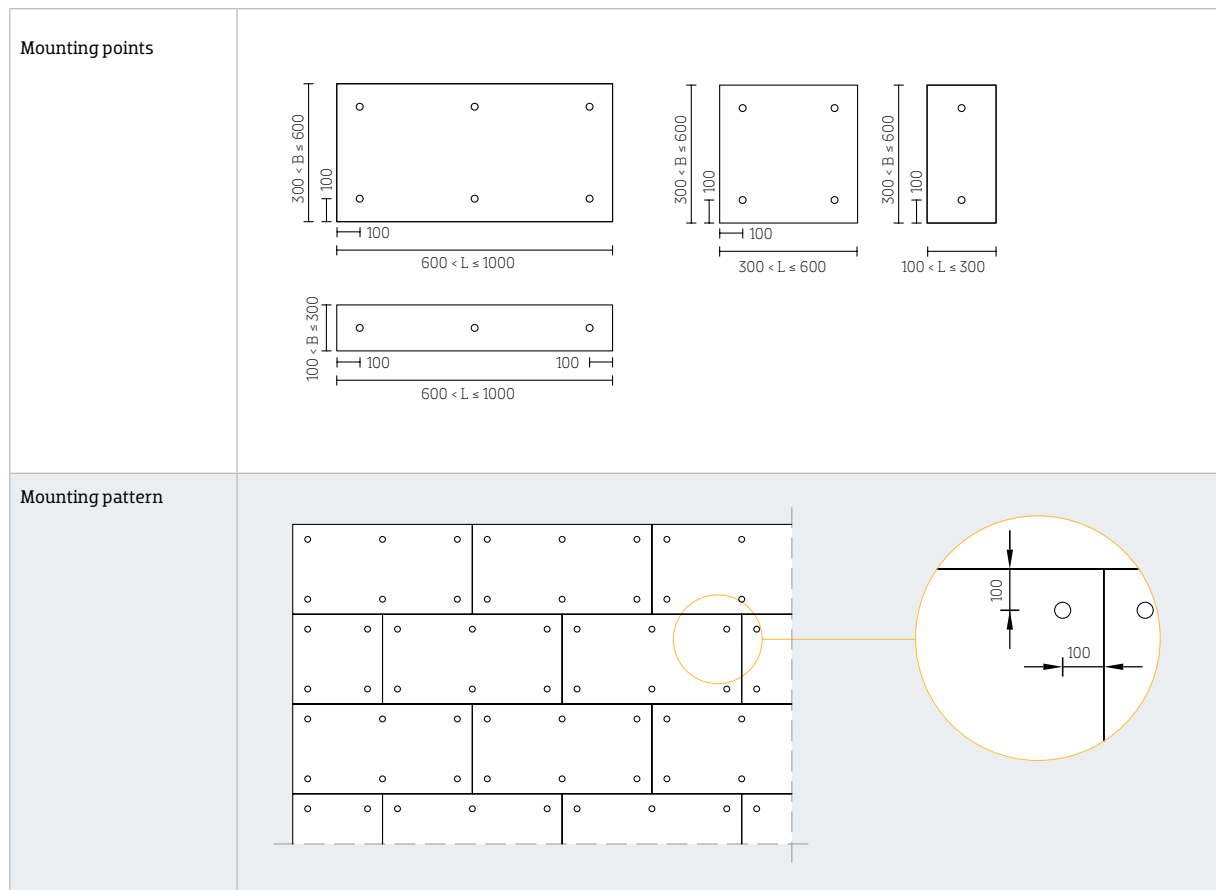

## 7.5.2 TEKTALAN A2 (50 MM - REI 180)

### Mounting surface

Solid concrete (2000-2600 kg/m<sup>3</sup>)

### Suitable Heraklith® mounting materials

Heraklith® | Concrete screw

### Applicable to

Heraklith® | Tektalan A2

Board thickness: 50 mm

### Fire-resistance

REI 180 [EN 1365-2 / EN 13501-2]

Report no.: 18203 [Warringtonfire, Gent]

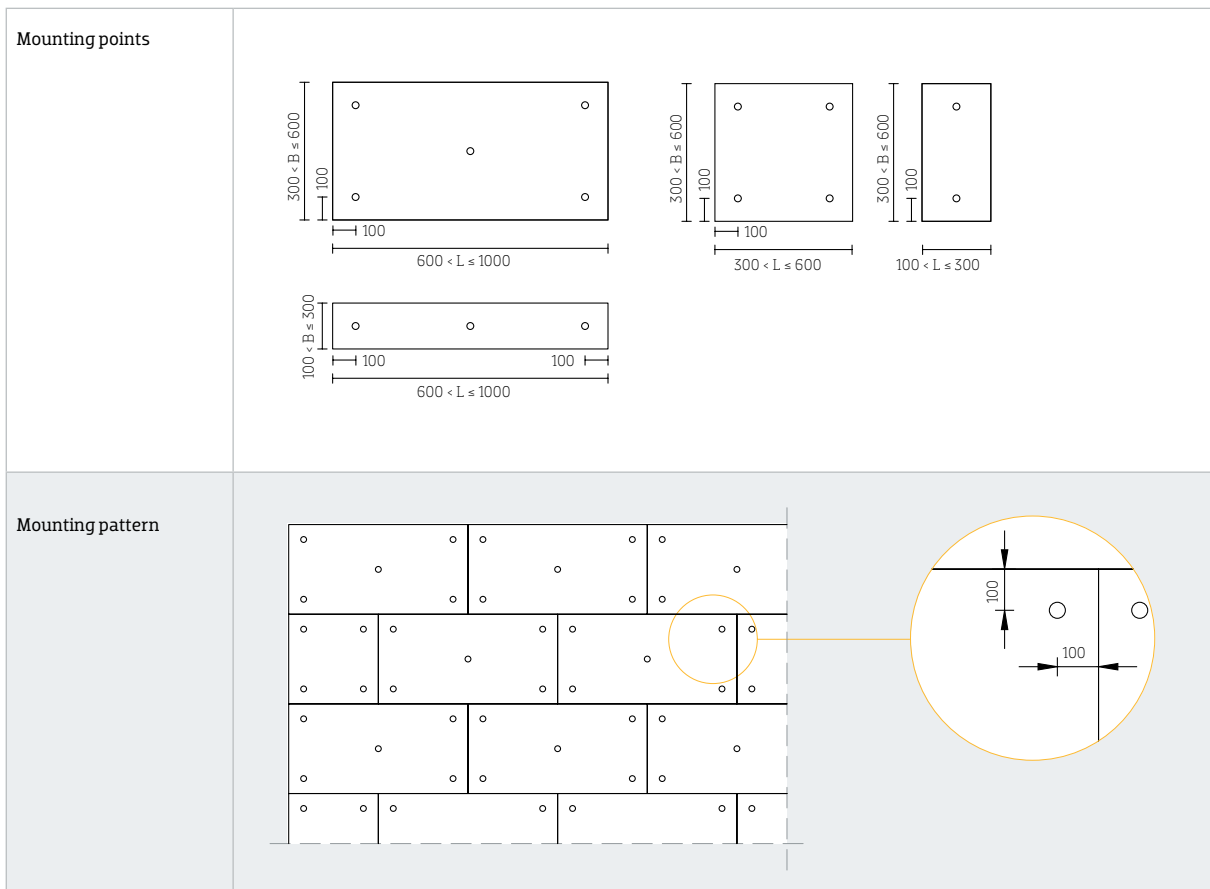

### 7.5.3 TEKTALAN A2 (75-150 MM - REI 180)

**Mounting surface**

Solid concrete (2000-2600 kg/m<sup>3</sup>)

**Suitable Heraklith® mounting materials**

Heraklith® | Concrete screw

**Applicable to**

Heraklith® | Tektalan A2

Board thickness: 75-150 mm

**Fire-resistance**

REI 180 [EN 1365-2 / EN 13501-2]

Report no.: 18204 [Warringtonfire, Gent]

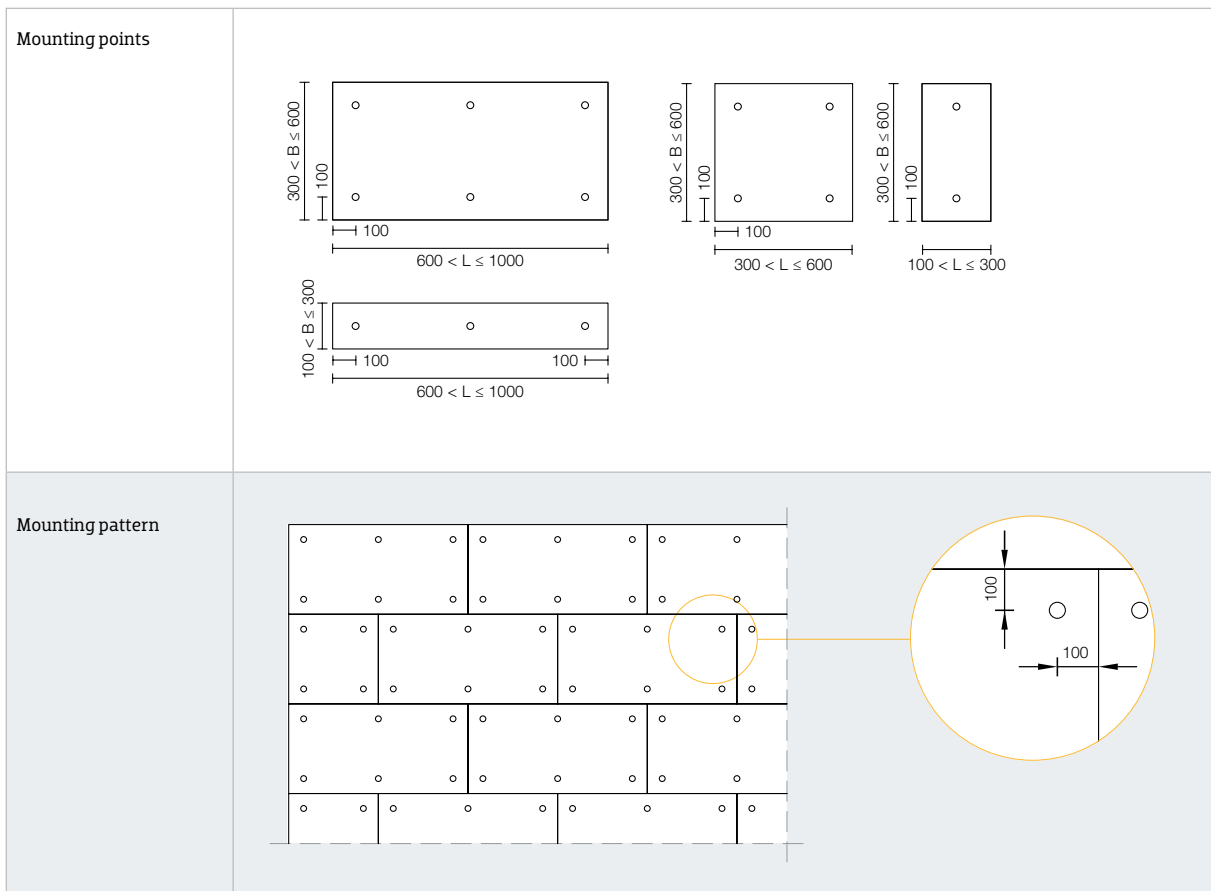

## 8 MOUNTING

### 8.1 GENERAL INSTRUCTIONS



Whenever possible use natural ventilation when mounting boards to keep dust levels to a minimum.



After contact with the product, skin should be rinsed in cold water to reduce the effects of mechanical irritation.



Minimise direct skin contact to avoid mechanical irritation. Wear suitable respiratory protection in dusty environments.



Whenever possible use extraction equipment.



Wear safety glasses when working above shoulder height or in dusty environments.



Dispose of excess product in accordance with local regulations.

- Never mount damaged boards. If you suspect that boards are damaged during production, you must report this immediately to the selling party where you ordered these boards. They can decide in consultation with you what the right next step is.

### 8.2 HANDLING BOARDS

- Tilt the boards up to take them off the pallet in order to avoid damaging them.
- Clean off any loose fibres and/or dust with a soft brush.
- Always work with clean hands and tools.

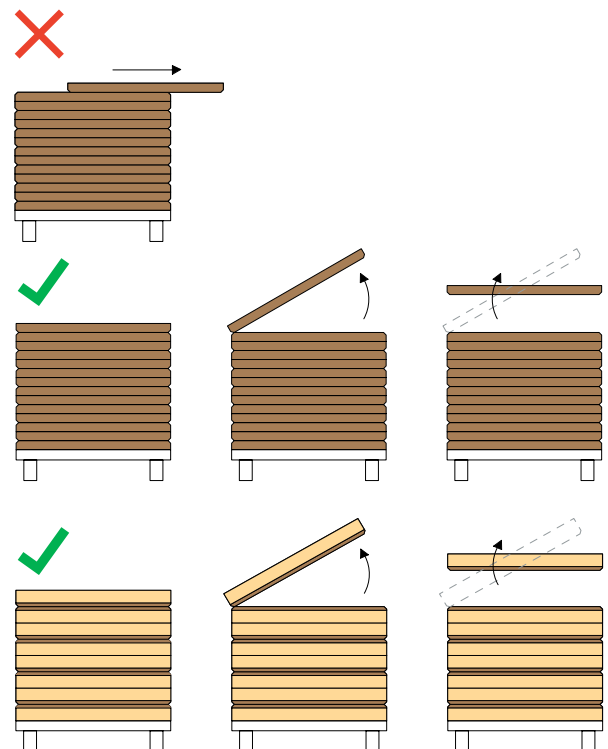

#### Attention!

See Section 10 for the method for handling painted boards.

### 8.3 MOUNTING DIRECTION

The boards stacked on the pallet have been placed in the same direction as they were manufactured and should be processed in this direction. Wood wool boards produced with faceted edges should preferably be mounted in a staggered pattern.

### 8.4 SAW ADVICE



#### Table saw

- Saw boards with the visible side up.
- Recommended sawblade: Carbide ("Widia") blade.



#### Handsaw

- Saw boards with the visible side up.
- The sawblade teeth must be suitable for wood.



#### Circular saw (clockwise rotation)

- Always use a guide rail.
- Depending on the rotation of blade, saw the boards with the visible side up.



#### Circular saw (anti-clockwise rotation)

- Always use a guide rail.
- Depending on the rotation of blade, saw the boards with the visible side down.



## 8.5 SOLID BOARDS TO CONCRETE

### Mounting surface

- Standard concrete (2000-2600 kg/m<sup>3</sup>)

### Suitable Heraklith® mounting materials

- Heraklith® | Anchor fixing [MSP]
- Heraklith® | Concrete screw

### Safety

Always take the recommended safety precautions given in paragraph 8.1.

### Tools

- Bench or circular saw<sup>A</sup> with a guide rail and a sawing depth greater than the board thickness.
- Recommended sawblade: Carbide ("Widia") blade
- Electric hammer drill<sup>B</sup> (the drill bit diameter depends on the choice of fastening screws (see paragraph 7.1 for details)
- Cordless drill<sup>C</sup> for predrilling the wood wool boards.
- For DDS plus concrete screws: Cordless drill with Torx 30.
- For Anchor Fixings [MSP]: Hammer drill with 'mounting accessory'. (Supplied as standard with Heraklith® Anchor Fixings).
- Telescopic prop<sup>D</sup>.
- Handsaw<sup>E</sup>.
- Other materials: tape measure/digital distance meter<sup>F</sup>, chalk line, trestles<sup>G</sup>.



### General

- Always work with clean hands and tools.
- Never place tools or other materials on the boards.  
Doing this can damage or break the boards.
- The number of fastening screws depends on the board type. Always refer to the recommended number of fastening screws for mounting boards given in paragraph 7.2 and for adaptor fittings given in paragraph 7.4.

### Fire resistance

For fire-resistant applications, always refer to the recommended number and type of fastening screws for different mounting surfaces given in paragraph 7.5.

### Any doubts about correctly mounting wood wool boards?

Always contact our customer service department before starting work.

#### 1 Cross-section A A

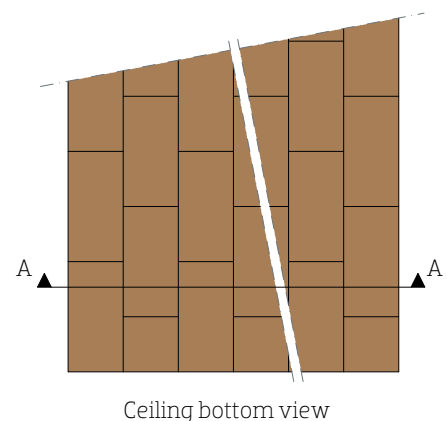
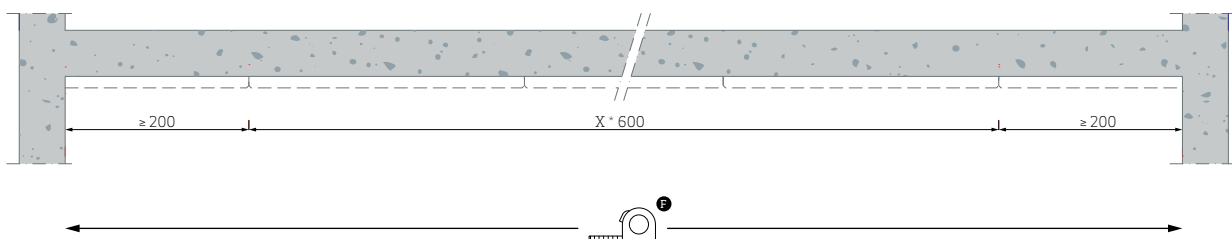

2

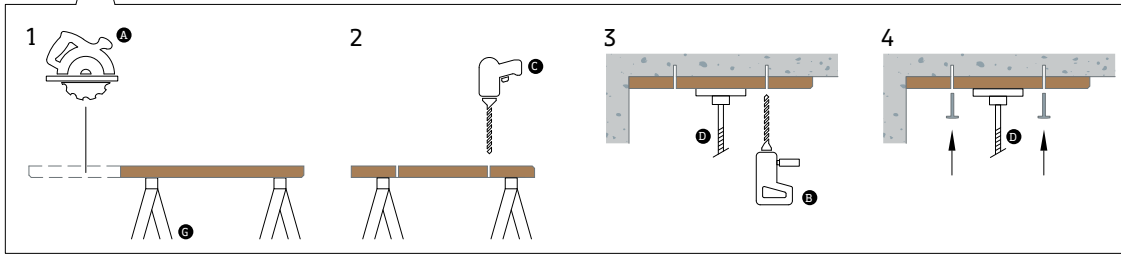
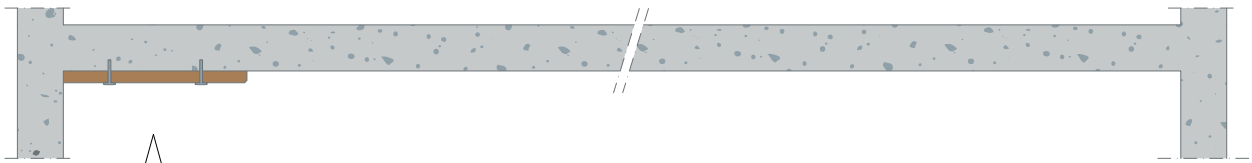

3

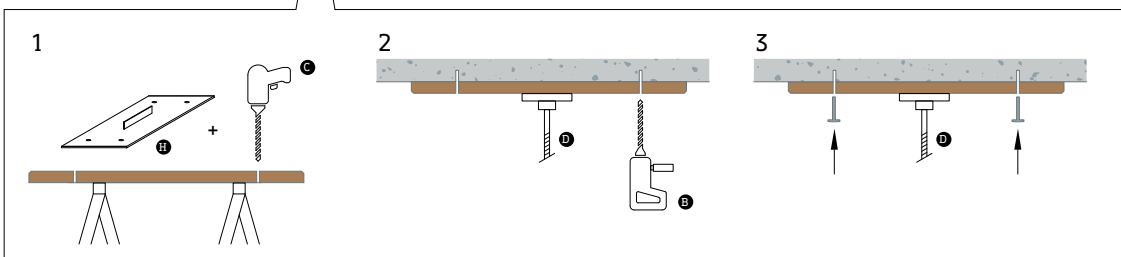
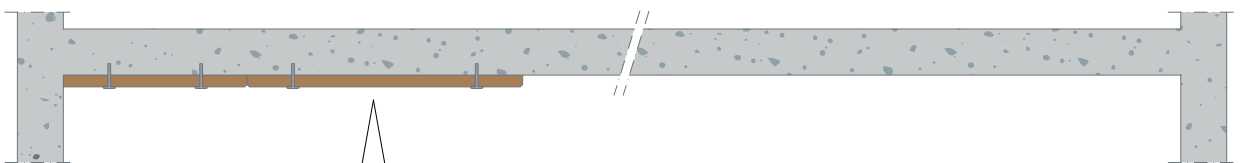

4

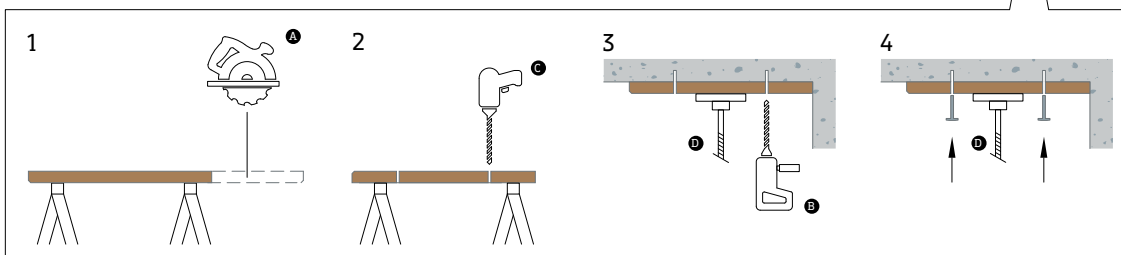
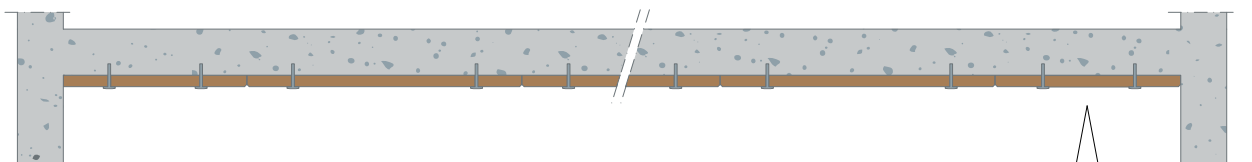

## 8.6 SOLID BOARDS ON WOODEN LATTICEWORK

### Applicable to

- Heraklith® | A2 board
- Heraklith® | Basic

### Suitable Heraklith® mounting materials

- Heraklith® | Wood screw

### Safety

Always take the recommended safety precautions given in paragraph 8.1.

### Tools

- Bench or circular saw<sup>A</sup> with a guide rail and a sawing depth greater than the board thickness.
- Recommended sawblade: Carbide ("Widia") blade.
- Cordless drill<sup>C</sup> for predrilling the wood wool boards.
- Telescopic prop<sup>D</sup>.
- Handsaw<sup>E</sup>.
- Other materials: tape measure/digital distance meter<sup>F</sup>, trestles<sup>G</sup>.



### General

- Always work with clean hands and tools.
- Never place tools or other materials on the boards. Doing this can damage or break the boards.
- The number of fastening screws depends on the board type. Always refer to the recommended number of fastening screws for mounting boards given in paragraph 7.2 and for adaptor fittings given in paragraph 7.4.

### Any doubts about correctly mounting wood wool boards?

Always contact our customer service department before starting work.

### Attention!

Take account of the tolerances in board dimensions when putting up lattice work.

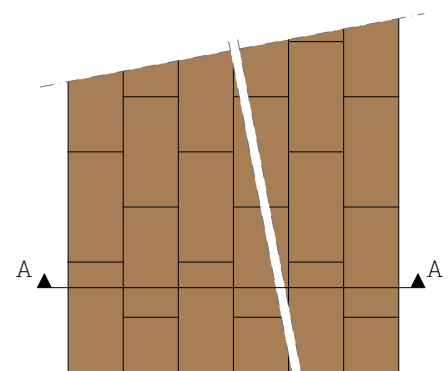

Ceiling bottom view

### 1 Cross-section A A

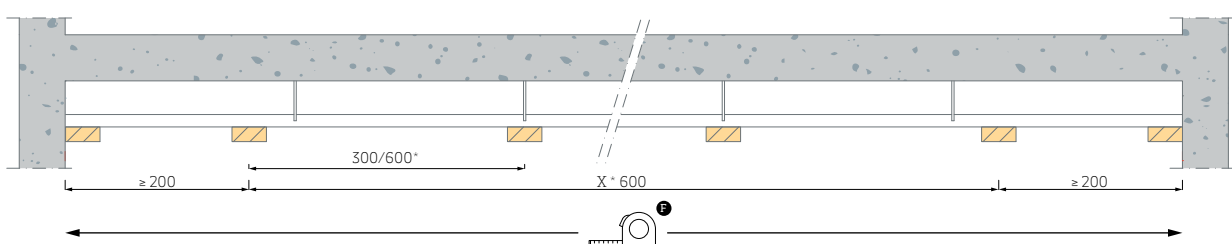

\* Board thickness 15 [mm]: centre-to-centre. 300mm  
Board thickness 25-50 [mm]: centre-to-centre. 600mm

2

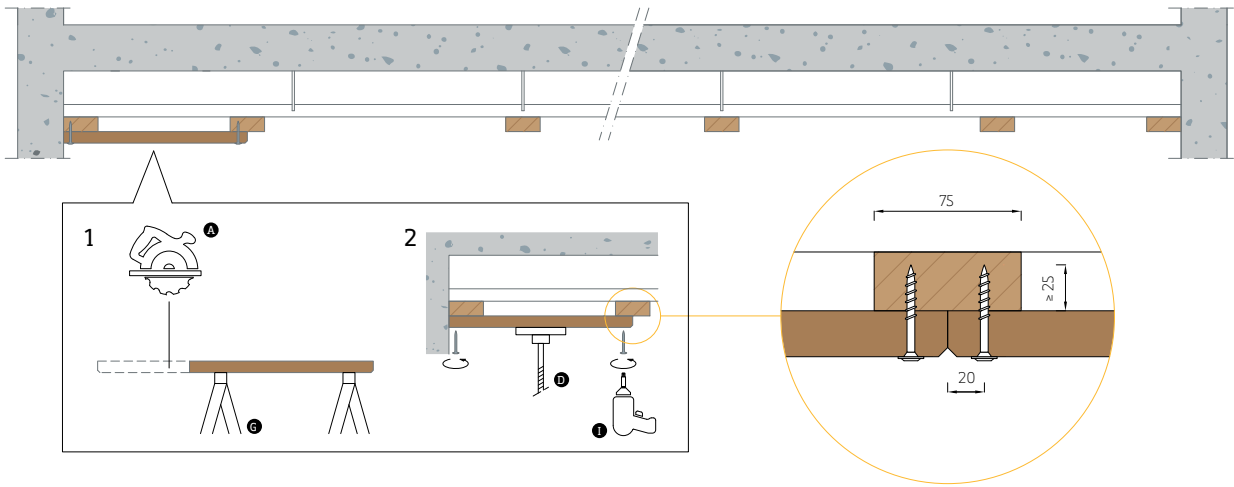

3

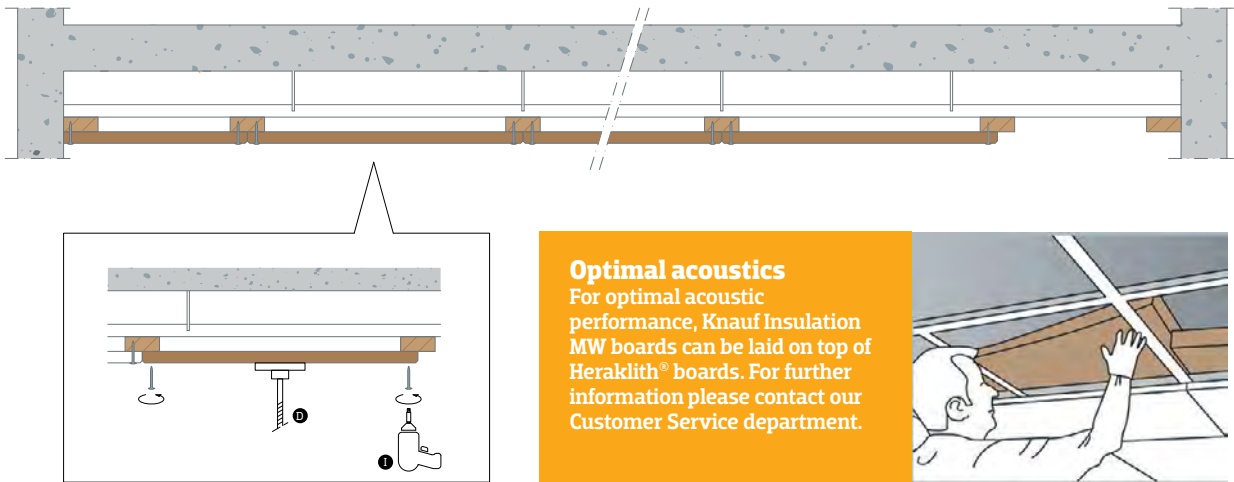

4

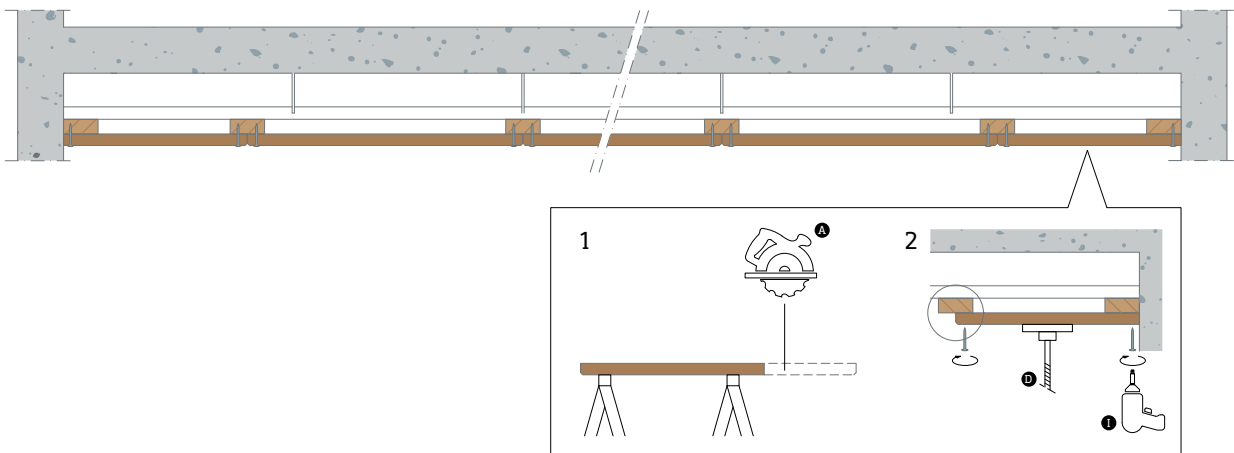

## 8.7 SOLID BOARDS TO METAL CD PROFILES

### Applicable to

- Heraklith® | A2 board
- Heraklith® | Basic

### Suitable Heraklith® mounting materials

- Heraklith® | Metal screw

### Safety

Always take the recommended safety precautions given in paragraph 8.1.

### Tools

- Bench or circular saw<sup>A</sup> with a guide rail and a sawing depth greater than the board thickness.
- Recommended sawblade: Carbide ("Widia") blade.
- Cordless drill<sup>C</sup> for predrilling the wood wool boards.
- Telescopic prop<sup>D</sup>.
- Handsaw<sup>E</sup>.
- Other materials: tape measure/digital distance meter<sup>F</sup>, trestles<sup>G</sup>.



### General

- Always work with clean hands and tools.
- Never place tools or other materials on the boards. Doing this can damage or break the boards.
- The number of fastening screws depends on the board type. Always refer to the recommended number of fastening screws for mounting boards given in paragraph 7.2 and for adaptor fittings given in paragraph 7.4.

### Any doubts about correctly mounting wood wool boards?

Always contact our customer service department before starting work.

### Attention!

Take account of the tolerances in board dimensions when putting up lattice work.

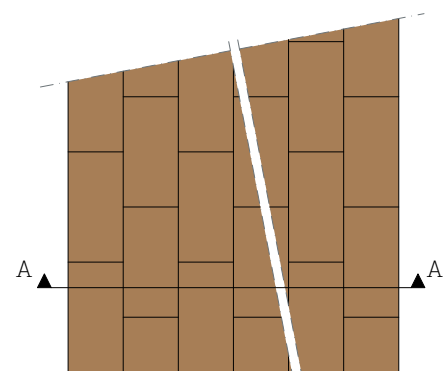

Ceiling bottom view

### 1 Cross-section A A

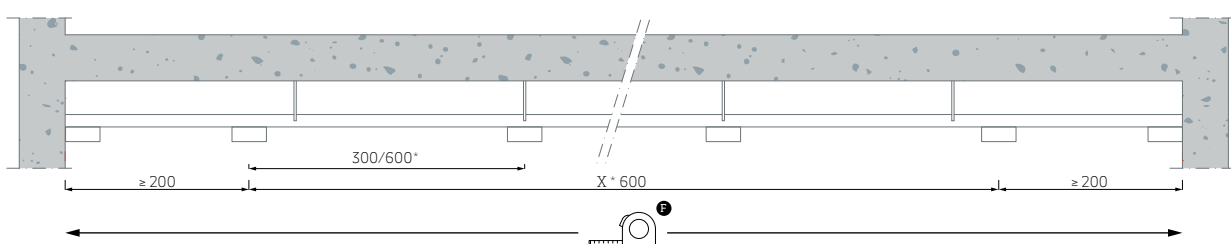

\* Board thickness 15 [mm]: centre-to-centre. 300mm  
Board thickness 25-50 [mm]: centre-to-centre. 600mm

2

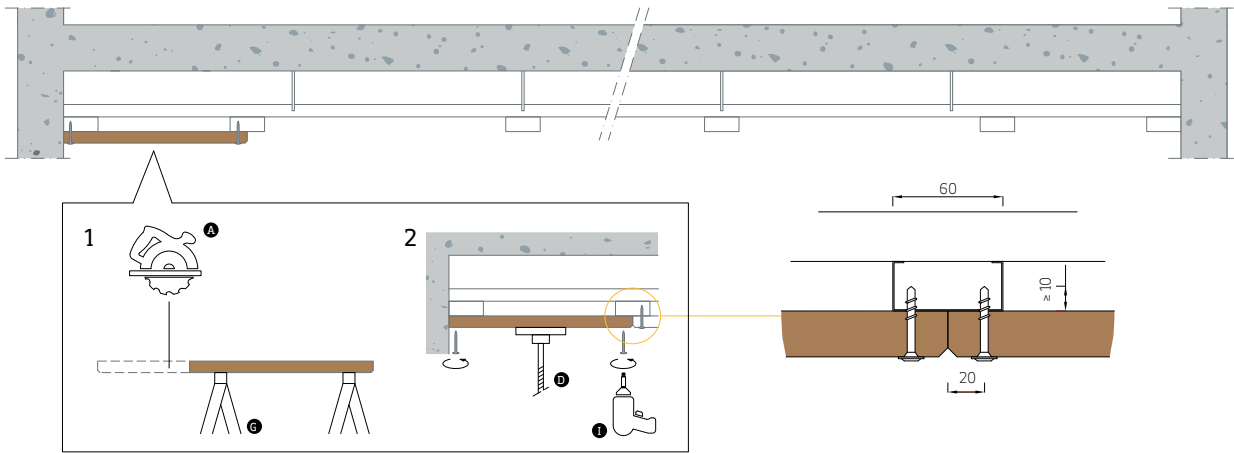

3

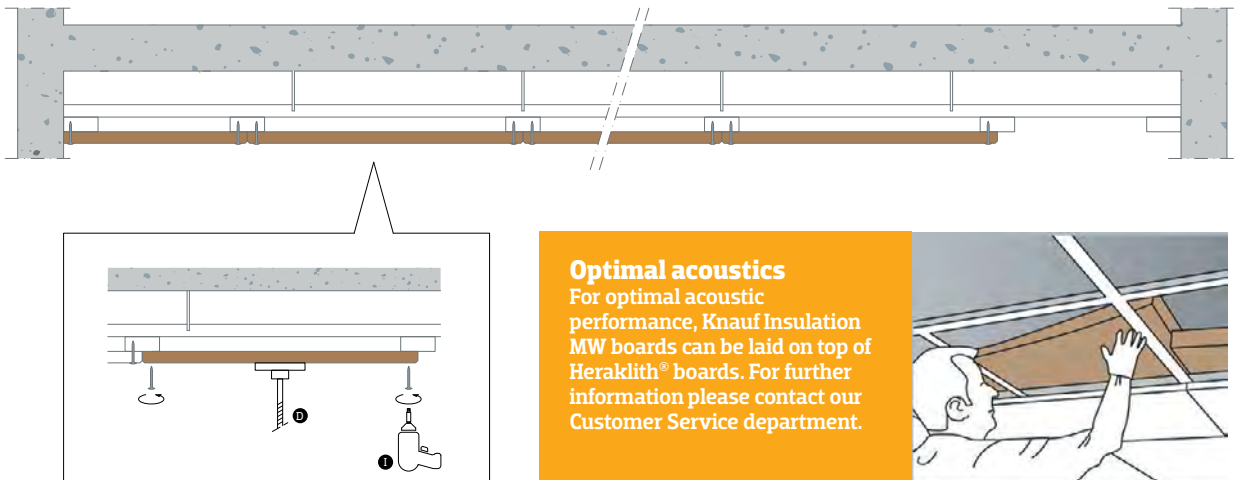

4

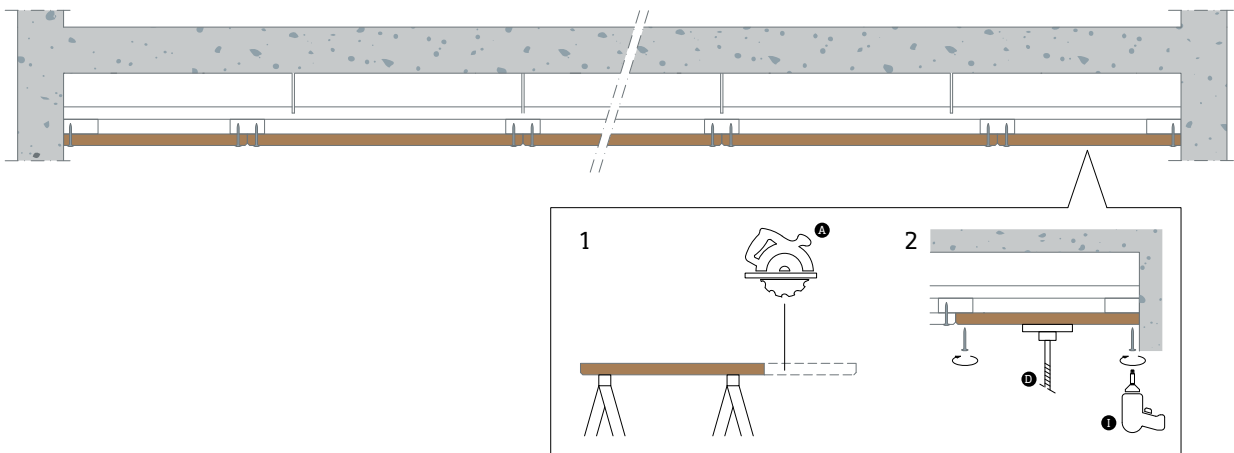

## 8.8 SOLID BOARDS IN A GRID CEILING SYSTEM

### System starting points

- This standard situation is based on a system with T24/38 main and T24/33 transverse profiles.

### Applicable to

- Heraklith® | A2 board, 15 and 25 mm inlay board

### Safety

Always take the recommended safety precautions given in paragraph 8.1.

### Tools

- Bench or circular saw<sup>A</sup> with a guide rail and a sawing depth greater than the board thickness.
- Recommended sawblade: Carbide ("Widia") blade.
- Cordless drill<sup>C</sup> for predrilling the wood wool boards.
- Telescopic prop<sup>D</sup>.
- Handsaw<sup>E</sup>.
- Other materials: tape measure/digital distance meter<sup>F</sup>, trestles<sup>G</sup>.

### General

- Always work with clean hands and tools.
- Never place tools or other materials on the boards. Doing this can damage or break the boards.



### Edge finishing inlay boards

- Inlay boards are made with straight edges. Boards of 25 mm and thicker have a bevelled top edge so they fit properly in a modular ceiling system.

Inlay boards are made with straight edges. Boards of 25 mm and thicker may have a bevelled top edge to fit properly in a modular ceiling system.

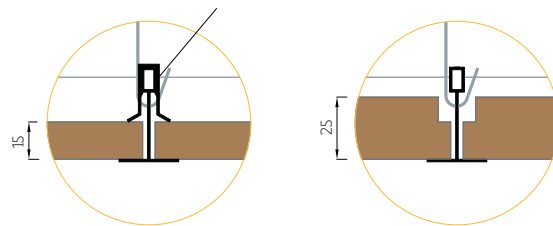

### Any doubts about correctly mounting wood wool boards?

Always contact our customer service department before starting work.

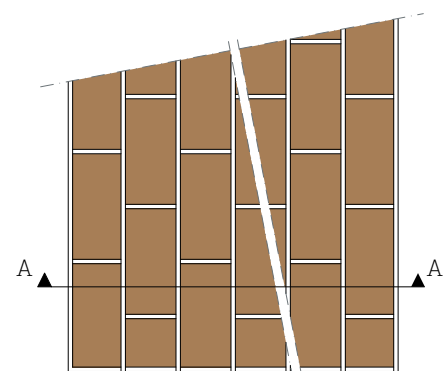

#### 1 Cross-section A A

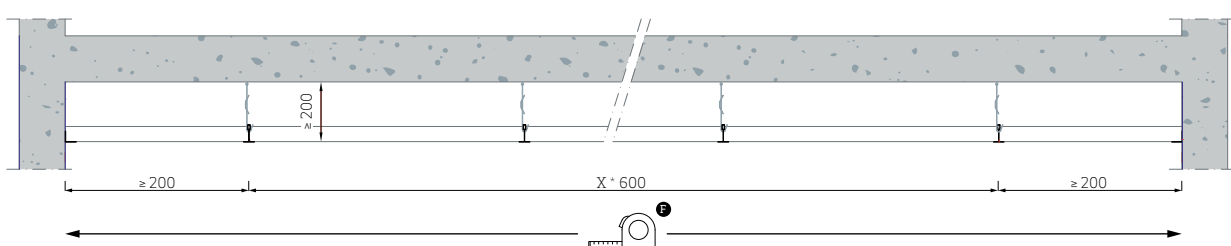

2

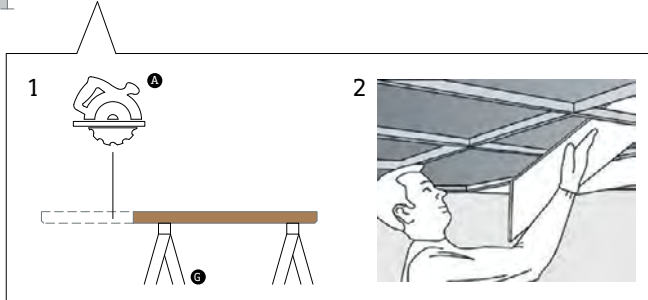
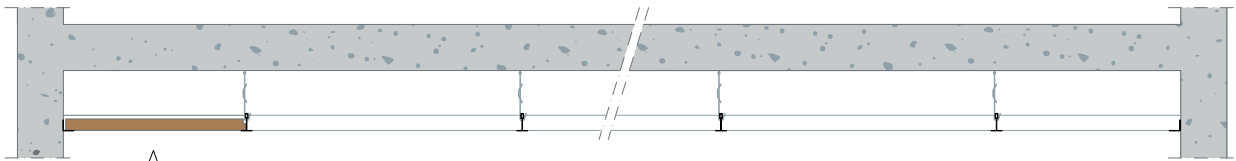

3

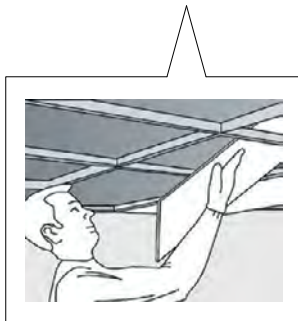
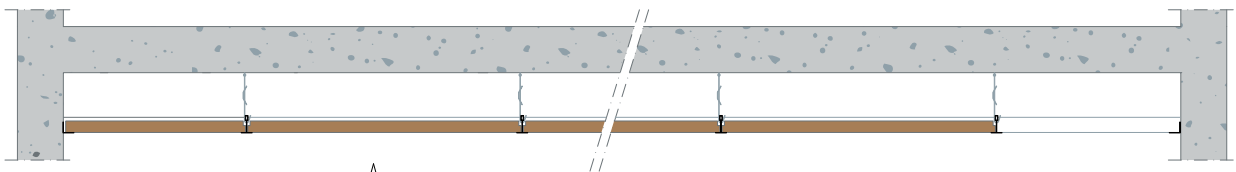

**Optimal acoustics**  
 For optimal acoustic performance, Knauf Insulation MW boards can be laid on top of Heraklith® boards. For further information please contact our Customer Service department.



4

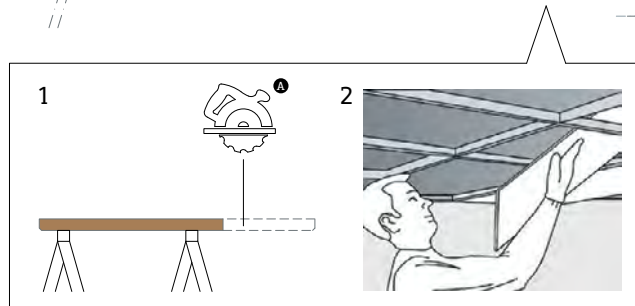
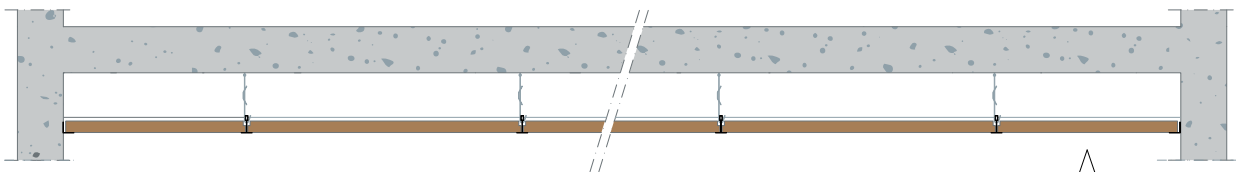



## 9 PENETRATIONS

To maintain the tested fire classification and fire resistance, it is essential that all transits are professionally sealed. Consider, for example, the following situations:

- Pipe penetrations of mechanical installations
- Cable and cable channel passages
- Gaps between the boards

Inquire with a recognized specialist about the solutions.

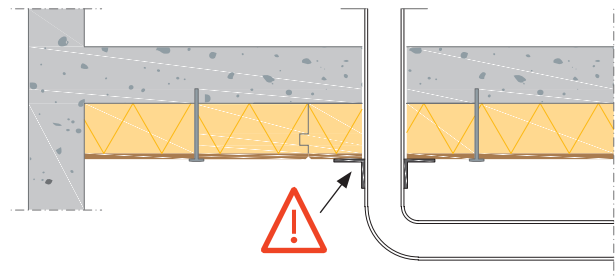

## 10 PAINTED BOARDS

Wood wool gives each Heraklith® board a unique characteristic open fibrous structure. The original colour of the wood wool will remain visible from some angles especially after painting during production in any colour that contrasts with the natural wood appearance. This is an inherent aspect of the manufacturing process of this natural product. This means that we cannot guarantee 100% coating.

In addition, it is practically impossible to mount boards with contrasting colours without dust or saw damage. We therefore always recommend touching up coloured boards or spraying them with a waterbased acrylic paint after mounting. The costs for refinishing boards are for your own account.

Heraklith® will, if necessary, place covering foil between the boards during packing to protect the wood fibres during transport and storage. Leave the foil in place as long as possible to minimise the risk of damage.

The following precautions should be taken when mounting Heraklith® coloured boards:

- Always handle boards in pairs with the visible sides pressed together with the covering foil from the factory inserted in between them to prevent damage.
- Tilt the boards off the pallet.
- When mounting wood wool boards, always wear clean dry gloves. Dirty and/or perspiring hands may stain the top coat.
- Mount the boards as quickly as possible after taking them off the pallet.

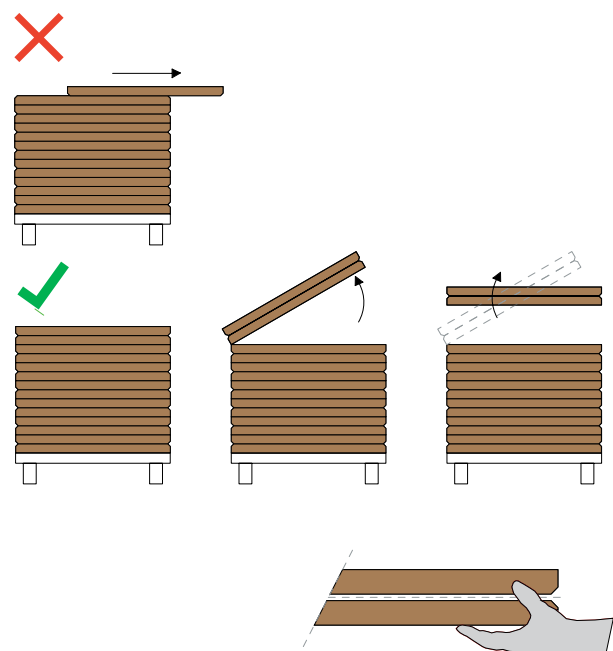

### Attention!

Leave the foil in place as long as possible to minimise the risk of damage to the surface.

## 11 PREVENTING MOISTURE SPOTS

Wood wool boards are insensitive to moisture. However, the coating provided in Knauf Insulation's factory may turn brown after contact with water. This is caused by the penetrating water dissolving pigments in the wood and transporting these pigments to the visible side of the board. The following solutions can be applied:

- Water in boards can be prevented with proper detailing, protecting and finishing in accordance with our guidelines.
- After drying, lightly scour the boards with fine sand paper (grit no. 80).
- Apply a light coat of Herapaint in the same RAL colour.

## 12 MAINTENANCE / CLEANING

Wood wool boards are easy to clean using a soft brush or compressed air. Do not use water to clean the boards.

## 13 SPECIFIC KNOWLEDGE

Although Heraklith® wood wool boards are delivered in combination with detailed processing instructions, the processing party must have sufficient specific knowledge of the way such products are processed in order to be able to apply the processing instructions correctly. The processing party is also entirely responsible for correctly processing the wood wool boards Knauf Insulation cannot be held liable in any way at all for any incorrect application. If in doubt, make sure to contact your supplier or visit our website **[www.heraklith.hu](http://www.heraklith.hu)** for additional information and product data.

## 14 FURTHER INFORMATION

For more information and terms & conditions, please contact your supplier:

If you are unable to get in touch with your supplier, please send an e-mail to: **[www.heraklith.hu/kapcsolat](http://www.heraklith.hu/kapcsolat)**.

Our general sales and delivery conditions apply to all our offers, communications and agreements, notwithstanding any provision to the contrary that can be found on our order forms or elsewhere. An overview of our general terms and conditions can be found on: [www.heraklith.hu/adatvedelmi-nyilatkozat](http://www.heraklith.hu/adatvedelmi-nyilatkozat). Extreme caution was observed when putting together and processing the information, texts and illustrations in this document. Nevertheless, errors cannot quite be ruled out. The publisher and editors cannot assume legal responsibility or any liability whatever for incorrect information and the consequences thereof.

KI-DS/Heraklith Processing instructions\_ENG\_05\_2022

Heraklith® is a registered  
trademark of  
**KNAUFINSULATION**