

# KNAUF

## D11.en

Drywall Systems

12/2024

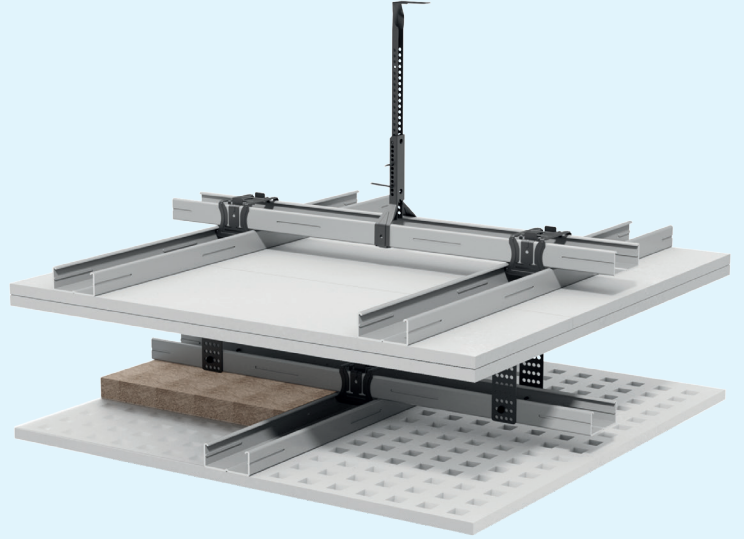

## Knauf Board Ceilings

D111.tr Knauf Board Ceiling with wood frame

D112.tr Knauf Board Ceiling with metal grid

D116.tr Knauf Board Ceiling with UA Profile

IMPORTANT

*This is a translation of the System Data Sheet valid in Turkey. This catalog contains system recommendations valid in Turkey and does not accept any responsibility for applications outside of Turkey. The current version of catalog should be checked from the [Document Center](#). The declared performance values must be supported by test reports and documents belonging to Knauf and It should be applied with the components recommended by Knauf, as recommended in the technical documentation and application manuals. Knauf does not carry any responsibility or liability in cases arising from outdated / expired documents, product modifications and changes, application phases and other such issues. We recommend that a non-significant divergence be coordinated and authorised in advance in consultation between the persons responsible for fire resistance and/or the relevant authorities. The stated constructional and structural properties, and characteristic building physics of Knauf systems can solely be ensured with the exclusive use of Knauf system components, or other products expressly recommended by Knauf. The validity and up-todatedness of the stated proofs have to be considered.*

**Build on us.**

# Contents

## Introduction

Usage instructions/General instructions .....	4
Dimensioning principles .....	5
Test reports .....	6
Systems .....	7

## Performance Recommendations

D111 Technical and physical building data .....	8
D112 Technical and physical building data .....	10
D116 Technical and physical building data .....	14
Airbone and impact sound insulation .....	18
Suspended ceiling systems construction details .....	20
Span widths / Perimeter spacing .....	22
Suspenders .....	23
Construction height .....	24
Anchoring of loads .....	25

## Construction details

D111 Knauf board ceiling with wood frame .....	26
D112 Knauf board ceiling with metal grid .....	28
D116 Knauf board ceiling with large-span metal grid .....	32
Special details .....	33

## Special versions

Connections to partitions .....	40
Fire resistance from above .....	43
Multi-level ceiling system .....	44



In addition to the application and detail information in this brochure;  
 One should take the information mentioned in the standard “TS 1475-3 GYPSUM PLASTERBOARD APPLICATIONS - PART 3: SUSPENDED CEILING APPLICATION RULES” published by TSE.

## Installation and application

Cladding .....	45
Grid .....	46
Board Fastening .....	48
Jointing .....	49
Coatings and linings .....	50
Delivery, storage and transportation .....	51

## Material consumption

Knauf board ceiling .....	52
---------------------------	----



In addition to the application and detail information in this brochure;

One should take the information mentioned in the standard “**TS 1475-3 GYPSUM PLASTERBOARD APPLICATIONS - PART 3: SUSPENDED CEILING APPLICATION RULES**” published by TSE.

### Usage instructions

#### Notes on the document

Knauf System Data Sheets are the planning and application basis in the application of Knauf systems. The contained information and specifications, constructions, details and stated products are based, unless otherwise stated, on the certificates and tests of usability. Additionally, fire resistance and sound insulation performance data are considered.

The contained construction details are examples and can be used in a similar way for various cladding variants of the respective system. At the same time, the demands made on fire resistance and/or sound insulation as well as any necessary additional measures and/or limitations must be observed.

#### Symbols

The following symbols are used in this document:

- G** Mineral wool is non-combustible in accordance with TS EN 13162. (e.g. Knauf Insulation)
- S** Mineral wool is non-combustible in accordance with TS EN 13162. melting point  $\geq 1000$  °C (e.g. Knauf Insulation)
- a** Spacing of suspenders/anchors
- b** Axial spacing of secondary / furring channels.
- c** Axial spacing of main channels.

### General instructions

#### Terms

Knauf board ceilings can be applied as ceiling linings or suspended ceilings. The following definition applied acc. to DIN 18168 and TS - 1475-3: Suspended ceilings consisting of sub-construction and Board coating can be applied in flat or curved forms and consist of perforated, smooth or shaped surfaces. the substructure is anchored directly to the load-bearing building components. (e.g. concrete slab)

All the performance values given in this catalogue is provided with minimum 0,6mm thick profiles.

#### Field of application

The data specified in this System Data Sheet only applies for ceiling linings/ suspended ceilings in interiors. For suspended ceiling systems to be applied on the exterior, it is recommended to use a cement-based Aquapanel® exterior board that is not affected by water. In suspended ceiling systems where Aquapanel® exterior board is applied, the sub-construction should be determined by considering the wind loads.

#### Fire resistance effect

If the fire resistance effect from the classification of Knauf board ceiling is achieved without involvement or consideration of the basic ceiling, the fire resistance is referred to as solely.

This is relevant in particular when the plenum is to be protected against the exposure to fire from the room (fire resistance solely from below) or a protective effect for the room against fire exposure in the plenum (fire resistance solely from above). A combination of both requirements may be necessary depending on the requirements and design.

With respect to the fire resistance solely, Knauf board ceilings can be

classified according to the interaction with the basic ceiling. If the type in quest in involves solid ceilings, they are categorized as types I to III acc. To DIN 4102-4.

Wood joist ceilings are categorized as type IV and are not dealt with in this System Data Sheet.

Fire resistance interacting with the basic ceiling is relevant from room to room with requirements on the fire resistance.

*Resrepresentation of the fire resistance effect:*

- Suspended ceilings allocated solely to a single fire resistance class
  - Room-enclosing

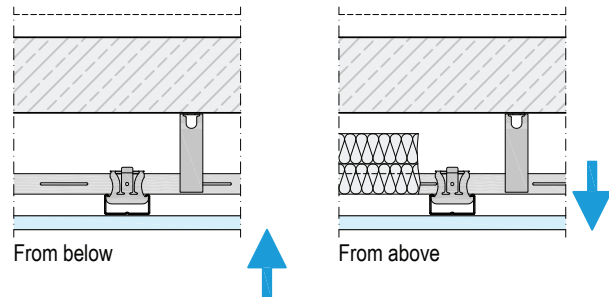

- Suspended ceilings in conjunction with basic ceilings
  - Room-enclosing
  - Structural stability in the event of a fire

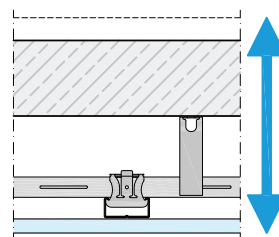

#### Dimensioning principles

To read off the required spacings for the grid, it is first of all necessary to determine the load class taking into consideration the self-weight of the selected system variant including any existing or planned additional loads.

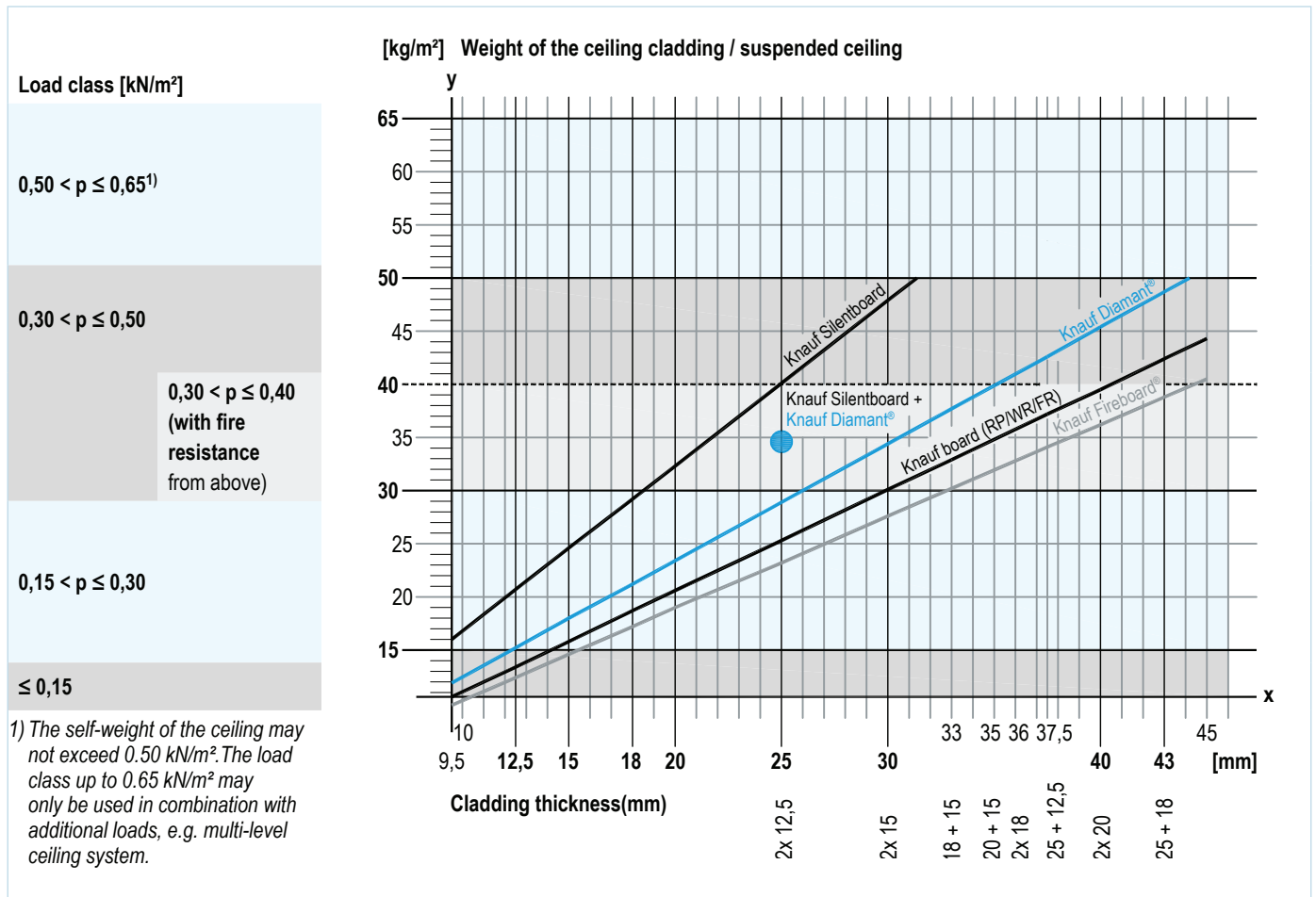

#### Step 1: Determination of the ceiling cladding / subceiling weight depending on the Knauf board thickness

The area weight of the ceiling lining / suspended ceiling including the substructure in kg/m<sup>2</sup> should be read off at the intersection point with the diagonals shown on the y-axis in dependence on the selected Board thickness in mm (x-axis).

#### Step 2: Consideration of additional loads

Additional loads consisting of fire resistance necessary and unnecessary insulation materials (max. 0.05 kN/m<sup>2</sup> = 5 kg/m<sup>2</sup>), as well as those from the system Multi-level Ceiling System (max. 0.15 kN/m<sup>2</sup> = 15 kg/m<sup>2</sup>) increase the total area weight of the ceiling cladding / suspended ceiling and must be considered with the dimensioning of the load class. The intersection point from the diagram determined with the diagonals must be offset by the level of the additional area load (kg/m<sup>2</sup>) in the direction of the y-axis (upwards).

#### Step 3: Determination of the load class

Based on the total area load of the ceiling lining / subceiling, the corresponding load class (kN/m<sup>2</sup>) is to be determined

#### Step 4: Dimensioning of the grid

Using the determined load class, the maximum permissible spacings of the suspenders **a** as well as the profiles/timber battens **b** and **c** can be read off from the tables on the technical and building physical data of the systems on the following pages.

\* All the performance values given in this catalogue is provided with minimum 0,6mm thick profiles.

### Documents and certificates

- This catalog contains system recommendations valid in Turkey and does not accept any responsibility for applications outside of Turkey. The current version of catalog should be checked from the Document Center. The declared performance values must be supported by test reports and documents belonging to Knauf and It should be applied with the components recommended by Knauf, as recommended in the technical documentation and application manuals.

For Knauf performance certificates and documents, please contact [teknik@knauf.com](mailto:teknik@knauf.com)

### Knauf Board Ceiling

Knauf ceiling systems consist of a suspended or directly anchored grid that is clad using gypsum boards. The numerous requirements from the applications are covered by a large and diverse range of options.

#### D111.tr Wood frame

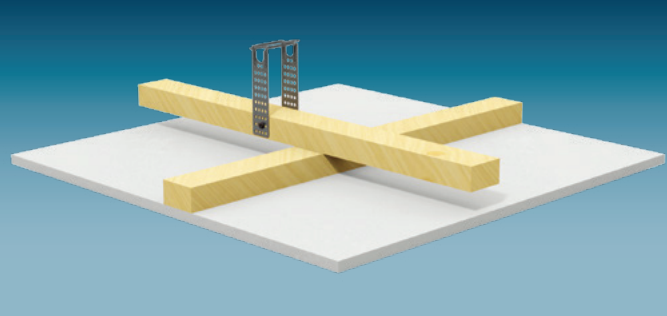

Knauf boards are fixed with screws to a wood frame made of carrying timber battens and furring timber battens (double batten frame) The grid is fastened using suspenders or is anchored directly to the basic ceiling using suitable fasteners

#### D112.tr Metal grid

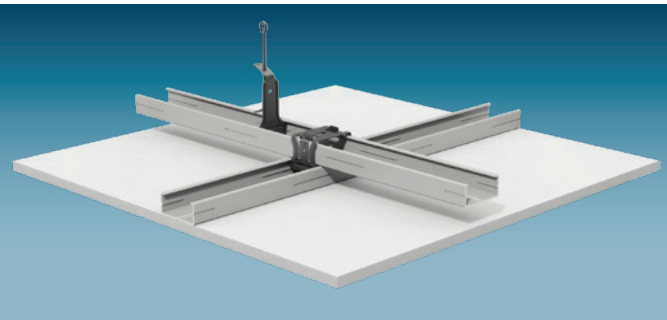

Knauf boards are fixed with screws to a metal grid made of carrying and furring channels (double layer profile) (TC 60/27 (0,6 mm) (0,6 mm)) Anchoring metal construction is undertaken with suspenders on the basic Ceiling by suitable dowel.

#### D116.tr Large-span metal gri -UA Profile

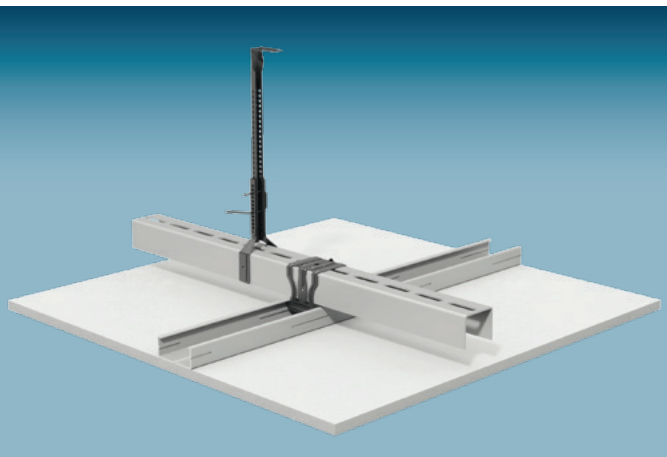

Knauf boards are fixed with screws to a metal grid of carrying channels UA 50 and furring channels TC 60/27 (0,6 mm) (0,6 mm) Anchoring of the grid is undertaken with suspenders on the basic ceiling by dowel. This system facilitates particularly large suspender spacings, e.g. for equipment installations in the plenum or with larger spacings between beams.

### Without fire resistance

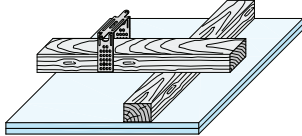
Requirements on the basic ceiling for fire exposure	Fire resistance		Cladding (lateral application)			Furring timber batten	Load class	Mineral Wool			
	For fire exposure		Regular Plus Gypsum Board	Knauf Diamant®	Knauf Silentboard			Minimum thickness	Max. axial spacings	Minimum thickness	Minimum density
	From below	From above									
<p><b>From below</b> No fire resistance requirements for basic ceiling/roof construction</p> <p><b>From above (Plenum)</b> Basic ceiling must have same fire resistance class as suspended ceiling</p>											
<b>D111.tr Knauf board ceiling with wood frame</b>											
 <p>e.g. carrying timber batten and furring timber batten</p>			■		2x12,5	500	0,30				
				■		2x12,5	500	0,30			
				■	■	12,5 + 12,5	400	0,50			

With combined cladding always use Diamant as a cover layer.

**Note** Observe the notes on page 4.

#### Maximum grid spacing

Dimensions in mm

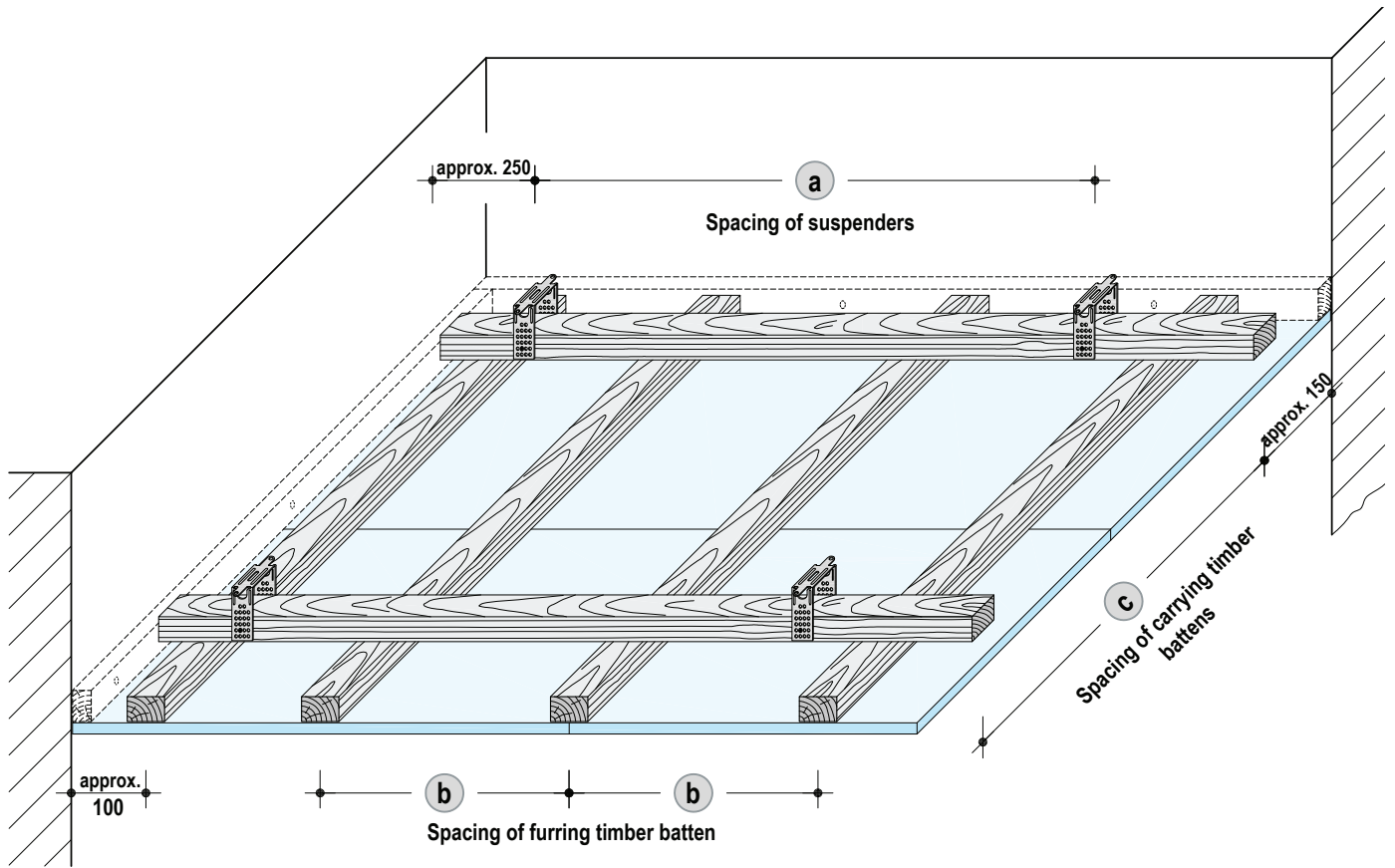

Without fire resistance – carrying timber batten and furring timber batten  $\geq 50 \times 30$  mm

Axial spacings Carrying timber batten c	Spacings of suspenders/anchor a		
	Load class in kN/m <sup>2</sup>		
	$\leq 0,15$	$\leq 0,30$	$\leq 0,50^{1)}$
500	1200	950	800
600	1150	900	750
700	1050	850	700 <sup>2)</sup>
800	1050	800	–
900	1000	800 <sup>2)</sup>	–
1000	950	–	–
1100	900	–	–
1200	900	–	–

Without fire resistance – furring timber batten only  $\geq 50 \times 30$  mm

Axial spacings furring timber batten b	Spacings of suspenders a		
	Load class in kN/m <sup>2</sup>		
	$\leq 0,15$	$\leq 0,30$	$\leq 0,50^{1)}$
$\leq 500$	1200	950	800
625	–	900	750
800	–	800	700

1) Use suspenders of load carrying capacity class 0.40 kN batten.

2) Not valid for furring batten spacing 800 mm b

For axial spacings of furring timber batten also refer to pages 8 and 24.

#### Note

Values given in system tables are Knauf recommendation. For more detailed information, please contact Knauf Technical department.

### Fire resistance solely from below and/or above (Vertical Board direction)<sup>1)</sup>

Requirements on the basic ceiling For fire exposure batten	Fire resistance		Cladding (lateral application)					Furring channel (0,6 mm)	Load class	Mineral Wool			
	For fire exposure		Regular Plus Gypsum Board	Knauf Diamant®	Knauf Silentboard	Knauf Fireboard®	Knauf Flameboard®			Minimum thickness mm	Max.axial spacings mm (b)	kN/m <sup>2</sup>	Required for fire resistance
	From below	From above											Minimum thickness mm
<b>From below</b> No fire resistance requirements for basic ceiling/roof construction  <b>From above (Plenum)</b> Basic ceiling must have same fire resistance class as suspended ceiling													
<b>D112.tr Knauf board ceiling with metal grid</b>			Fire test report origin										
			-	De	De	De	Tr*						
<p>e.g. carrying channel and furring channel</p>	-	-	■					12,5	500	0,15	-		
			■					2x12,5		0,30			
	F30	-	■					2x12,5	500	0,30	Without or with A class Mineral wool (G)		
				■				2x12,5	400	0,30			
	EI60	-				■		2x15	500	0,50	Without or with A class Mineral wool (G)		
	F90	-				■		2x20	500	0,30			
	EI90	-				■		15+25	500	0,50			
EI120	-				■		2x25	500	0,50				
	-	F30	■					15	500	0,30	Mineral wool class A 40 40 (S)		
			■					2x12,5	500	0,50	+ Mineral wool class A 40 40 (S)		
	F30	F30		■				2x12,5	400	0,50	150 mm wide on carrying channel		
						■		15	400	0,30	Mineral wool class A 2x40 40 (S)		
	F90	F90				■		2x20	500	0,30	Mineral wool class A 40 40 (S) + Mineral wool class A 40 40 (S) 150 mm wide on carrying channel		

<sup>1)</sup>Board direction should be applied vertically. For details, see P. 63. For other applications, TS 1475-3 should be taken into account.

■ Fire resistance;

Tr\* - Internal test data of Knauf Laboratories. It is not accredited.

De - Test report data with Knauf Germany system components.

#### Additional information for fire resistance

Divergences from the construction variants pages 12 and 13 Prior consultation in acc. to Page 6 is recommended.

#### Note

(G) (S) Observe the notes on page 4. For details of application of the carriers together with the main flooring, see P. 22.

#### Maximum grid spacings

Dimensions in mm

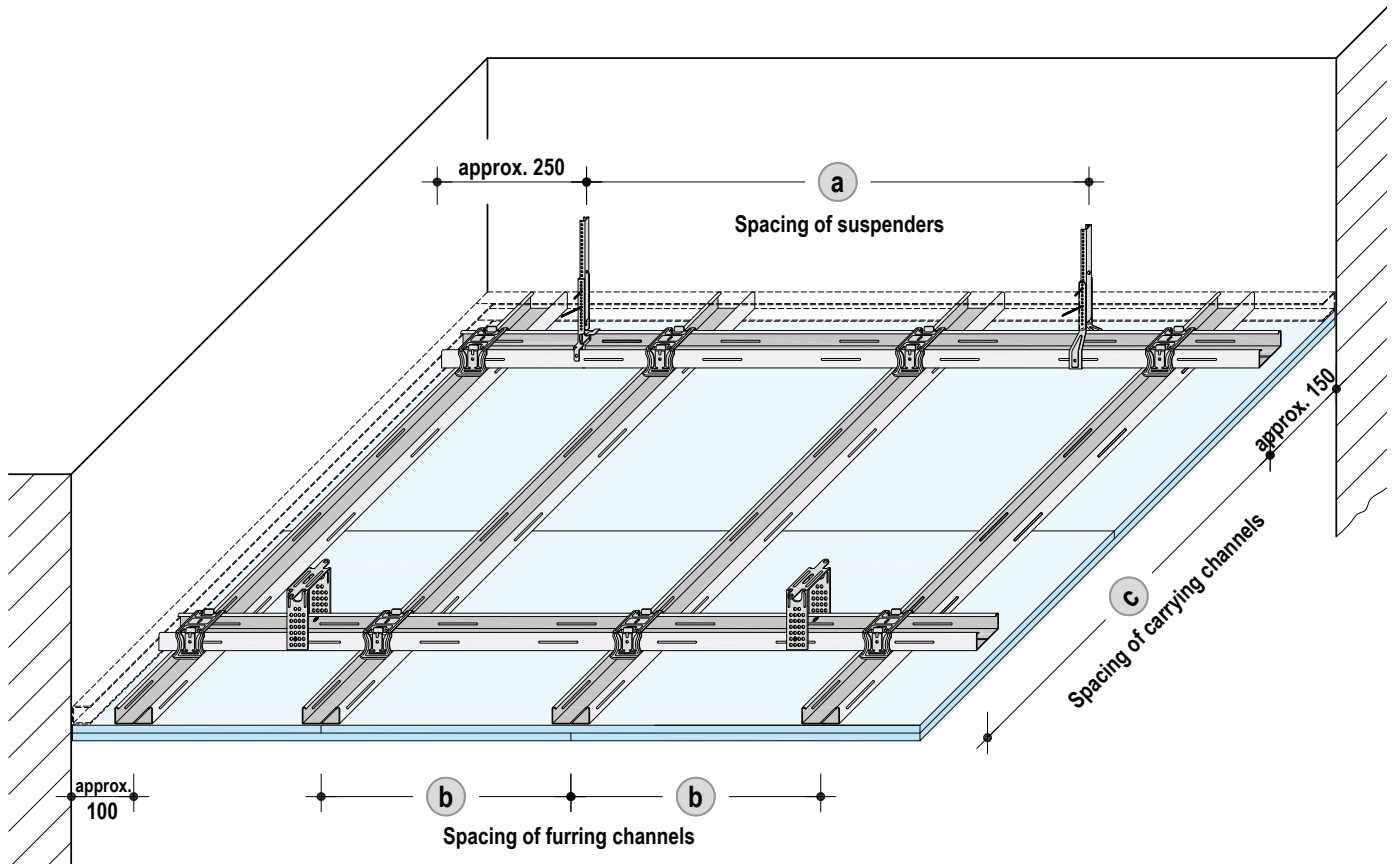

Without fire resistance/fire resistance solely from below – carrying and furring channel

Axial spacings carrying channel <b>c</b>	Suspender spacing <b>a</b> Load class in kN/m <sup>2</sup>			
	≤ 0,15	≤ 0,30	≤ 0,50 <sup>1)</sup>	≤ 0,65 <sup>1)</sup>
500	1200	950	800	750
600	1150	900	750	700
700	1100	850	700 <sup>2)</sup>	650
800	1050	800	700 <sup>2)</sup>	–
900	1000	800	–	–
1000	950	750	–	–
1100	900	750 <sup>2)</sup>	–	–
1200	900	–	–	–

Fire protection solely (from below and) from above – carrying and furring channel

Axial spacings carrying channel <b>c</b>	Suspender spacing <b>a</b> Load class in kN/m <sup>2</sup>			
	≤ 0,30	≤ 0,40 <sup>1)</sup>	≤ 0,50 <sup>1)</sup>	≤ 0,65 <sup>1)</sup>
500	950	850	800	700
600	900	800	700	700
700	850	750	700 <sup>3)</sup>	650 <sup>3)</sup>
800	800	–	–	–

1) Use suspenders of load carrying capacity class 0.40 kN.

2) Not valid for furring **b** channel spacing 800mm.

3) Permissible furring channel spacing **b** maks. 500 mm.

For axial spacings of furring channel also refer to pages 10 and 24.

\* All the performance values given in this catalogue is provided with minimum 0,6mm thick profiles.

#### Caution

Values given in system tables are Knauf recommendation. For more detailed information, please.

#### Note

Observe additional constructional measures with fire resistance solely from above in accordance with page 47. it is recommended that the substructure is designed to accommodate a possible additional ceiling (≤ 0.15 kN/m<sup>2</sup>).

### Fire protection solely from below and/or from above

**Note**

The system variants shown here generally show the exact system variants as in the Technical Tests. Divergences, e.g. use of other suspenders, other spacings of the grid as well as other cladding are possible in accordance with the specifications on pages 10 and 11. The notes acc. to page 6 apply accordingly.

#### Knauf board ceiling D112.tr with metal grid

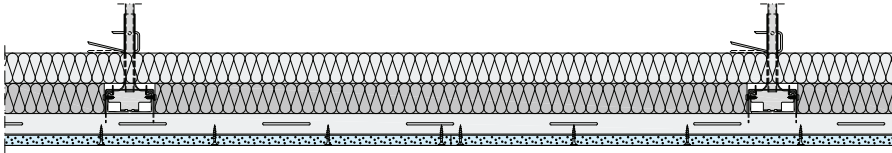

- Fire protection class F30 solely from below and above
- Double layer profile (carrying and furring "C" channel)
- With insulation layer

Design alternatives		
<b>Connection to solid walls</b>	Perimeter runner	TU 28/27 (0,6 mm), fastening spacing ≤ 300 mm
<b>Suspension</b>	Description	Nonius hanger, spacing a ≤ 750 mm (≤ 900 with fire resistance solely from above) (please screw TC profile )
	Suspension height	≤ 1500 mm (with fire resistance from above)
<b>Grid</b>	Carrying channel	TC 60/27 (0,6 mm), axial spacing c ≤ 850
	Furring channel	mm TC 60/27 (0,6 mm), axial spacing
	Connection of the profiles	b ≤ 400 mm clips
<b>Mineral wool EN 13162</b>	Thickness	2x40 mm
	Density	≥ 40 kg/m <sup>3</sup>
	Melting point acc. to DIN 4102-17	≥ 1000 °C
<b>Cladding</b>	Board thickness/type	≥ 15 mm Knauf Fireboard®, single layer
	Maximum board size	≤ 1200 mm x 2500 mm
	Fastening	SU Drywall screw 3,5x25
	Spacing of fasteners	≤ 150 mm

Test data achieved with Knauf Germany system components.

#### Fire protection solely from below and/or from above

**Note**

The system variants shown here generally show the exact system variants as in the Technical Tests. Divergences, e.g. use of other suspenders, other spacings of the grid as well as other cladding are possible in accordance with the specifications on pages 10 and 11. The notes acc. to page 6 apply accordingly.

#### Knauf board ceiling D112.tr with metal grid

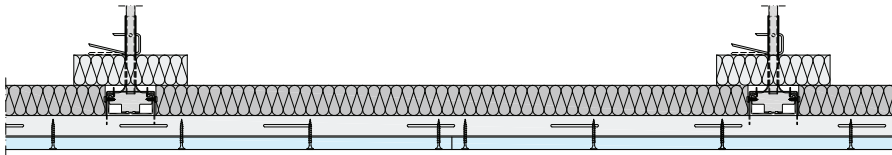

- Fire protection class F30 solely from below and above
- Double layer profile (carrying and furring "C" channel)
- With insulation layer

#### Design alternatives

<b>Connection to solid walls</b>	Perimeter runner	TU 28/27 (0,6 mm), fastening spacing ≤ 600 mm
<b>Suspension</b>	Description	Nonius hanger, spacing a ≤ 800 mm (please screw TC profile)
	Suspension height	≤ 1500 mm
<b>Grid</b>	Carrying channel	TC 60/27 (0,6 mm), axial spacing ≤ 800 mm
	Furring channel	TC 60/27 (0,6 mm), axial spacing
	Connection of the profiles	b ≤ 400 mm clips
<b>Mineral wool EN 13162</b>	Thickness	1x40 mm (additional 150 mm wide strip on carrying channels)
	Density	≥ 40 kg/m <sup>3</sup>
	Melting point acc. to DIN 4102-17	≥ 1000 °C
<b>Cladding</b>	Board thickness/type	≥ 15 mm Fireboard, single layer
	Maximum board size	≤ 1200 mm x 2500 mm
	Fastening	SU Drywall screw 3,5x35
	Spacing of fasteners	≤ 170 mm

Test data achieved with Knauf Germany system components.

#### Knauf board ceiling D112.tr with metal grid

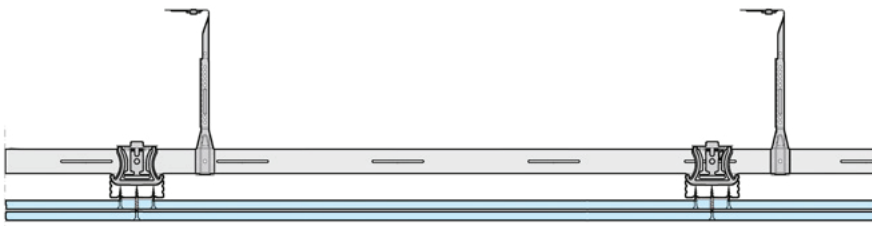

- Fire protection class EI120\* solely from below
- Double layer profile (carrying and furring "C" channel)
- Without insulation layer

#### Design alternatives

<b>Connection to solid walls</b>	Perimeter runner	TU 28/27 (0,6 mm), fastening spacing ≤ 400 mm
<b>Suspension</b>	Description	Nonius hanger, spacing a ≤ 700
<b>Grid</b>	Carrying channel	TC 60/27 (0,6 mm), axial spacing c ≤ 800
	Furring channel	TC 60/27 (0,6 mm), axial spacing b ≤ 500mm
	Connection of the profiles	clips
<b>Cladding</b>	Board thickness/type	2x25 mm Flameboard®
	Maximum board size	≤ 1200 mm x 2500 mm
	Fastening	SU Drywall screw 3,5x35 (first layer), SU Drywall screw 3,9x70 (second layer)
	Spacing of fasteners	≤ 510 mm (first layer), ≤ 170 mm (second layer)

\*Data given according to Knauf internal test report.

### Fire protection solely from below and/or from above (Board direction is vertical)<sup>1)</sup>

Requirements on the basic ceiling For fire exposure	Fire resistance class		Cladding (lateral application)					Furring channel (0,6 mm)	Load class	Mineral wool	
	For fire exposure		Regular Plus Gypsum Board	Knauf Diamant®	Knauf Silentboard	Knauf Fireboard®	Knauf Flameboard®			Minimum thickness	Max.axial spacings (b)
	From below	From above						mm	mm		
<b>From below</b> No fire resistance requirements for basic ceiling/roof construction  <b>From above (Plenum)</b> Basic ceiling must have same fire resistance class as suspended ceiling											
<b>D116.tr Knauf board ceiling with large-span metal grid (UA profile)</b>			Fire test report origin								
			-	De	De	De	Tr*				
	-	-	■					12,5	500	0,15	-
			■					2x12,5	500	0,30	-
	F30	-	■					2x12,5	500	0,30	Without or with A class Mineral wool (G)
				■				2x12,5	400	0,50	
	F90	-			■			2x20	500	0,30	
	EI90	-				■		15+25	500	0,50	
EI120	-					■	2x25	500	0,50		
		F30	■					15	500	0,30	Mineral wool class A (S) 60 50
				■				2x12,5	500	0,50	+ Mineral wool class A (S) 60 50 100 mm wide on carrying channel
	F30	F30		■				2x12,5	500	0,50	Mineral wool class A (S) 40 40
					■			2x12,5	400	0,50	+ Mineral wool class A (S) 40 40 150 mm wide on carrying channel
						■		15	400	0,30	Mineral wool class A (S) 2x40 40
	F90	F90				■		2x20	500	0,30	Mineral wool class A (S) 40 40 + Mineral wool class A (S) 40 40 150 mm wide on carrying channel

<sup>1)</sup>Board direction should be applied vertically. For details, see P. 63. For other applications, TS 1475-3 should be taken into account.

- Fire resistance;
- Tr\* - Internal test data of Knauf Laboratories. Given based on D112 system test.
- De - Accredited test report data with Knauf Germany system components

#### Additional information for fire resistance

- Divergences from the construction variants pages 16 and 17  
Prior consultation in acc. to Page 6 is recommended.

#### Note

(G) (S) Observe the notes on page 4. For details of application of the carriers together with the main flooring, see P. 18.

#### Maximum grid spacings

Dimensions in mm

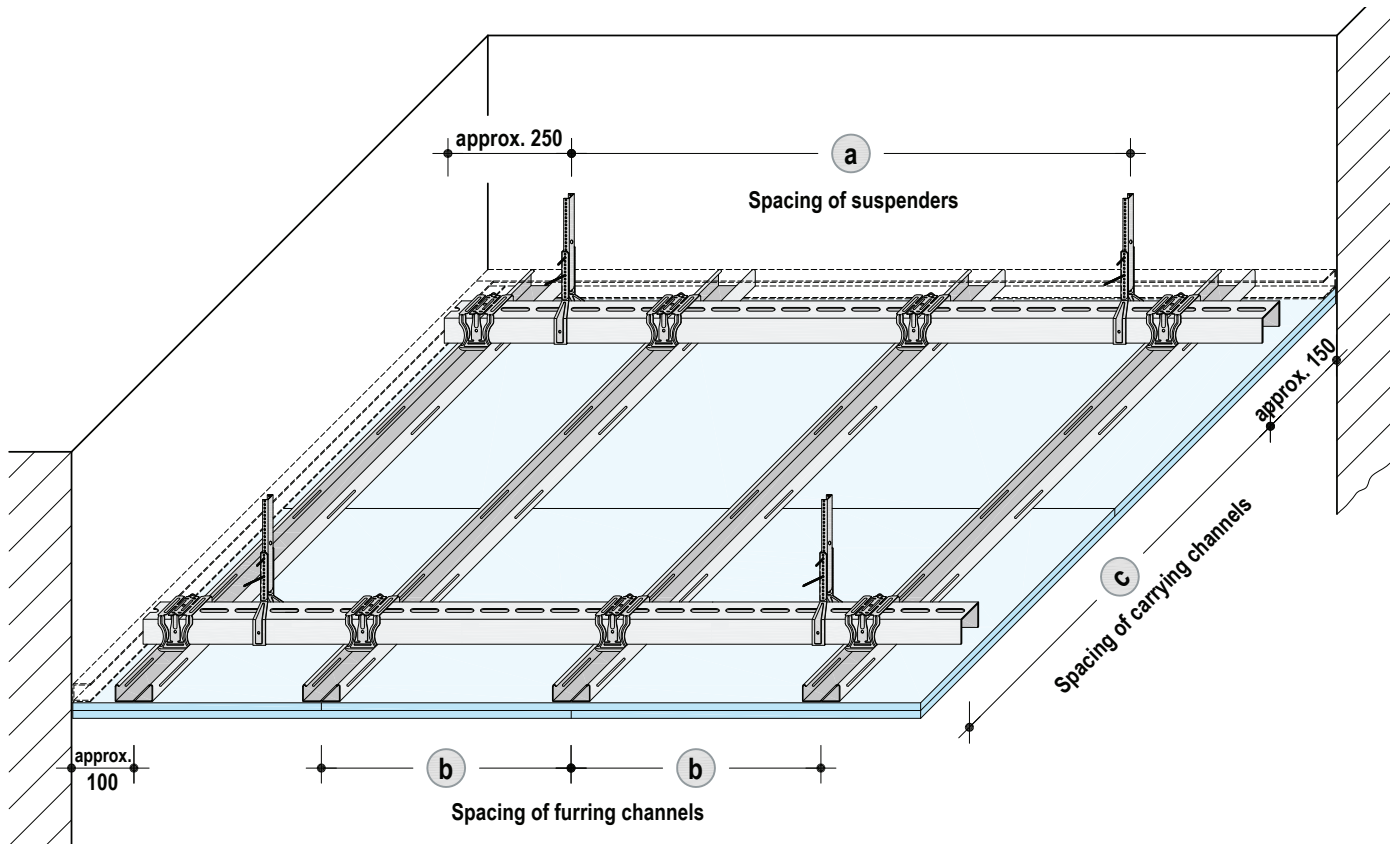

Without fire resistance/fire resistance solely from below – carrying and furring channel

Axial spacings carrying channel (c)	Suspender spacing (a)			
	Load class in kN/m <sup>2</sup>			
	≤ 0,15	≤ 0,30	≤ 0,50	≤ 0,65
Nonius stirrup 0,40 kN				
500	2600	2050 <sup>1)</sup>	1600	1200
600	2450	1950 <sup>1)</sup>	1300	1000
700	2300	1850 <sup>1)</sup>	1100 <sup>2)</sup>	850
800	2200	1650	1000 <sup>2)</sup>	–
900	2150	1450	–	–
1000	2050	1300	–	–
1100	2000	1200 <sup>2)</sup>	–	–
1200	1950	–	–	–
1300	1900	–	–	–
1400	1850	–	–	–
1500	1750	–	–	–

Without fire resistance/fire resistance solely from above and below – carrying and furring channel

Axial spacings carrying channel (c)	Suspender spacing (a)			
	Load class in kN/m <sup>2</sup>			
	≤ 0,30	≤ 0,40	≤ 0,50	≤ 0,65
Nonius stirrup 0,40 kN				
500	1150	1000	950	850
600	1050	950	900	800
700	1000	900	850	750
800	950	850	800	–
900	900	800	–	–
1000	900 <sup>3)</sup>	–	–	–
1000	1300 <sup>3)</sup>	1200 <sup>3)</sup>	–	–

1) With fire resistance solely from below: Spacing of suspen (a) maks. 1700 mm

2) Not valid for furring (b) channel spacing 800mm

3) Only permissible for furring channel (b) spacing maks. 500 mm

For axial spacings of furring channel also refer to pages 14 and 24.

\* All the performance values given in this catalogue is provided with minimum 0,6mm thick profiles.

#### Caution

Values given in system tables are Knauf recommendation. For more detailed information, please contact Knauf Technical department.

#### Note

Observe additional constructional measures with fire resistance solely from above in accordance with page 47. It is recommended that the grid is designed to accommodate a possible additional ceiling (≤ 0.15 kN/m<sup>2</sup>)

### Fire protection solely from below

**Note**

The system variants shown here generally show the exact variants as in the Technical Tests. Divergences, e.g. use of other suspenders, other spacings of the grid as well as other cladding are possible in accordance with the specifications on pages 18 and 19. The notes acc. to page 6 apply accordingly.

### Metal Knauf board ceiling D116.tr with large-span metal grid



- Fire protection class EI120 solely from above
- Double layer profile (carrying and furring channel)
- Without insulation layer

Design alternatives		
<b>Connection to solid walls</b>	Perimeter runner	TU 28/27 (0,6 mm), fastening spacing $\leq$ 300 mm
<b>Suspension</b>	Description	Nonius hanger, spacing $a \leq$ 2000 mm,
	Suspension height	$\leq$ 1500 mm
<b>Grid</b>	Carrying channel	UA 50, axial spacing $c \leq$ 500 mm
	Furring channel	TC 60/27 (0,6 mm), axial spacing $b \leq$ 500 mm
	Fastening	UA Clips
<b>Cladding</b>	Board thickness/type	2x25 mm Flameboard
	Maximum board size	$\leq$ 1200 mm x 2500 mm
	Fastening	SU Drywall screw 3,5x25
	Spacing of fasteners	$\leq$ 150 mm

\*Given based on internal test report with D112 system.

#### Fire protection solely from below and/or from above

**Note**

The system variants shown here generally show the exact variants as in the Technical Tests. Divergences, e.g. use of other suspenders, other spacings of the grid as well as other cladding are possible in accordance with the specifications on pages 18 and 19. The notes acc. to page 6 apply accordingly.

#### Insulation

##### D116.tr Knauf board ceiling (UA profile)

Single-layer insulation strips to protect profiles

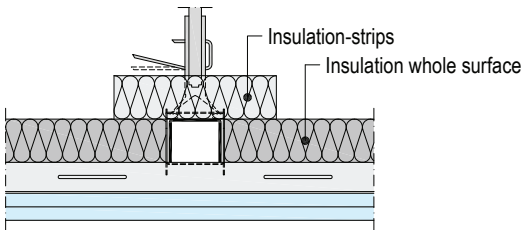

##### Double-layer insulation

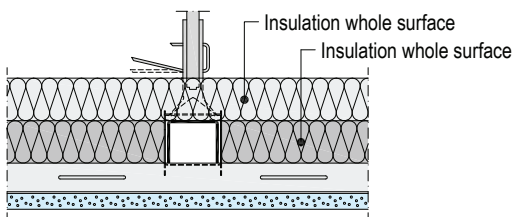

### Airborne and impact sound insulation

Dimensions in mm

Basic Ceiling Reinforced concrete ceiling 140 mm, approx. 320 kg/m <sup>2</sup>	Without floor		Basic ceiling + floor Knauf dry floor screed			
	$R_{w,R}$ dB	$L_{n,w,R}$ dB	$R_{w,R}$ dB	$L_{n,w,R}$ dB	$R_{w,R}$ dB	$L_{n,w,R}$ dB
			<ul style="list-style-type: none"> <li>1x18 mm Brio WF</li> </ul>		<ul style="list-style-type: none"> <li>2x23 mm Brio</li> <li>20 mm Knauf Insulation mineral wool</li> </ul>	
Without suspended ceiling	51	82	56	59	60	51
Basic ceiling + suspended ceiling D112		Basic ceiling + floor + suspended ceiling				
 ■ 12,5 mm Knauf Diamant®	68	57	67 <sup>1)</sup>	48	70 <sup>1)</sup>	43
 ■ 15 mm Knauf Diamant®	≥ 68 <sup>3)</sup>	≤ 57 <sup>3)</sup>	70	47	≥ 70 <sup>3)</sup>	≤ 43 <sup>3)</sup>
 ■ 2x12,5 mm Knauf Diamant®	72	54	72 <sup>1)</sup>	43	76 <sup>1)</sup>	37
 ■ 12,5 mm Knauf Silentboard	70	52	70 <sup>1)</sup>	45	74 <sup>1)</sup>	38
 ■ 12,5 mm Knauf Silentboard ■ 12,5 mm Knauf Diamant®	72	51	73 <sup>1)</sup>	42	77 <sup>1)</sup>	36
 ■ 2x12,5 mm Knauf Silentboard	73	50	74 <sup>1)</sup>	41	77 <sup>1)</sup>	34

1) Calculation based on the detailed procedure acc. To DIN EN 12354.

2) Measured values of basic ceiling and suspended ceiling without flooring.

3) Calculation values derived from cladding 12.5 mm.

Larger suspension heights / larger thicknesses of the basic ceiling improve sound insulation.

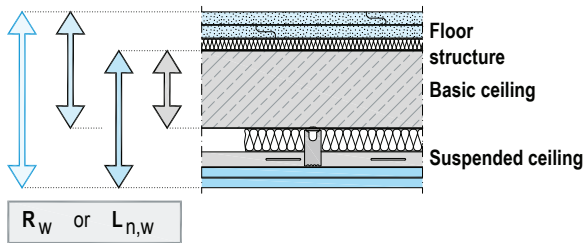

#### Suspended ceiling D112.tr

Furring channel TC 60/27 (0,6 mm)

Mineral wool 30 mm, acc. to EN 13162

length-related flow resistance acc. to DIN EN 29053  $r \geq 5 \text{ kPa}\cdot\text{s}/\text{m}^2$

(e.g. Knauf Insulation IPB 037 Mineral Plus, TP 115 or TI 140 T)

Universal bracket

Cladding

#### Terms

- $R_w$  = weighted sound reduction index in dB without sound transmission via flanking building components.
- $L_{n,w}$  = weighted normalized impact sound level in dB without sound transmission via flanking building component.
- Index R is used to differentiate between the calculation value and the test stand values

#### Verification acc. to (E DIN 4109:2013)

The verification of the DIN 4109:2013 currently in the draft phase is no longer according to calculation values, but rather with the values obtained on the test rig rounded off to a single position following the decimal point.

Only at the end of the forecast after consideration of all the perimeter surfaces (flanking surfaces) involved in the transmission of sound is an element of forecast uncertainty included in dependence on the type of separating constructional component.

Should test rig values not be available, the forecast can be performed on the safe side with the calculation values + margin.

If the margin has not been expressed separately and is thus not evident from these documents, a margin of 2 dB can be applied.

### Flanking normalized level difference of Knauf board ceiling under solid ceilings

Construction examples Knauf system D112.tr		Cladding	Weighted normalized level difference $D_{n,f,w}$		
			Without Mineral wool layer	With full surface Mineral wool layer	
Suspension height 400 mm		Min. Thickness mm	dB	$\geq 50$ mm dB	$\geq 80$ mm dB
<b>Connection of partition to suspended ceiling</b> Continuous cladding		Single-layer $\geq 12,5$	48	49	50
		Double-layer $\geq 2 \times 12,5$	55	56	56
<b>Connection of partition to suspended ceiling</b> Separated cladding		Single-layer $\geq 12,5$	50	54	56
		Double-layer $\geq 2 \times 12,5$	57	59	59

The values can be used up to a suspension height of 400 mm. Should the suspension height exceed 400 mm, the values should be reduced by 1 dB. By provision of a board bulkhead the normalized level difference can be raised by 20 dB, however only up to a maximum of 67 dB.

#### Flanking normalized level difference of Knauf board ceiling under solid ceilings

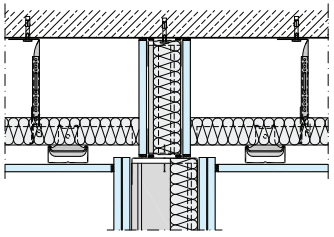
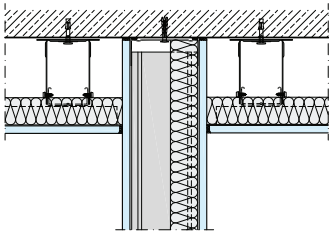
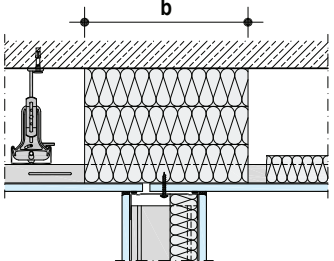
<b>Construction examples</b> Knauf system D112.tr  Suspension height 400 mm	<b>Cladding</b>  Min. Thickness mm	<b>Weighted normalized level difference <math>D_{n,f,w}</math></b> With mineral wool $\geq 40$ mm dB	
<b>Separation of the plenum</b> By a bulkhead made of boards		Single-layer $\geq 12,5$	67
<b>Connection of partition to solid ceiling</b> The cladding up to the solid ceiling acts effectively as a separating bulkhead for the plenum		Single-layer $\geq 12,5$	67
<b>Connection of partition to suspended ceiling</b> Cladding separated with absorbent bulkhead <sup>1)</sup> $\geq 400$ mm		Double-layer $\geq 12,5$	62

1) Absorbent bulkhead made of mineral wool acc. to TS EN 13162, length related flow resistance value  $r \geq 8 \text{ kPa}\cdot\text{s}/\text{m}^2$

Improvement factors of the weighted normalized level difference  $D_{n,f,w}$  of suspended ceilings for table on page 32 using an absorbent bulkhead with horizontal sound transmission in accordance with the table on page 32.

Minimum width of the absorbent bulkhead $b$ in mm	Improvement factor in dB
300	12
400	14
500	15
600	17
800	20
1000	22

- Absorbent bulkhead made of mineral wool acc. to TS EN 13162, length related flow resistance value  $r \geq 8 \text{ kPa}\cdot\text{s}/\text{m}^2$
- The highest value for the table on page 22 and the improvement factor can only be a maximum of 62 dB.

### Permissible cladding span widths (lateral cladding)

Dimensions in mm

Knauf board thickness	Maximum spacings furring timber batten/furring channel <sup>b</sup>		Ball impact safety D112 Universal Bracket/Nonius suspension
	Without fire resistance	With fire resistance	
12,5 Knauf Silentboard	400	Spacings of the furring channels acc. to pages 10, 14, 18, 23, 24, 25	400
12,5 / 2x12,5	500		500
15 / 2x15	550		
18 / 25+18	625		
20 / 2x20	625		
25	800		

When coating with a plaster of layer thickness  $\geq 6$  mm (e.g. cooling ceilings) furring channel axial spacing  $\leq 312.5$  mm. Observe the additional load due to the plaster layer when dimensioning the grid in accordance with page 5.

### Perimeter spacings of the grid (Scheme drawings - examples)

Dimensions in mm

#### Alternative 1: Non-load-bearing connection (connection is not used for load-bearing of the ceiling)

- Without perimeter joint backing
- Backing with TU runner as installation aid, in case of fire resistance and sound protection, spacing of anchors of TU runner **up to approx. 1 m**

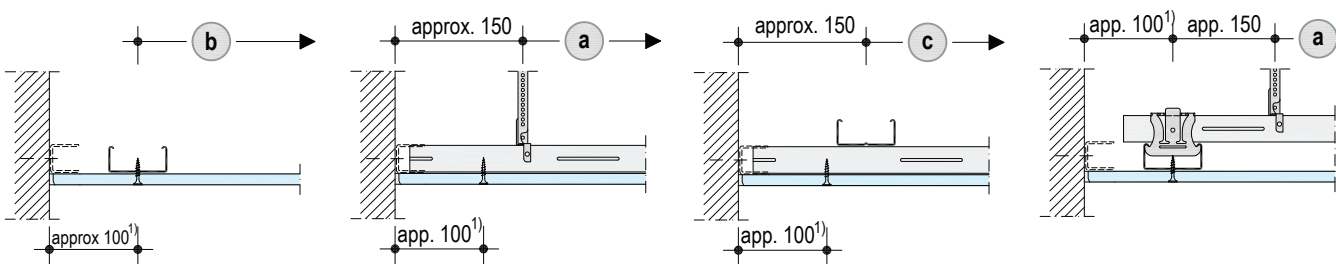

#### Alternative 2: Load-bearing connection

- The spacing of the TU runner anchors is reduced to  $\leq 600$  mm (for fire resistance too). Use fasteners and anchors suited to the substrate.
- In load-bearing TC runners, the carrying / furring channels should be inserted by at least 20 mm.
- The maximum permissible spacings for suspenders, carrying / furring channels are given in the tables for the respective systems.

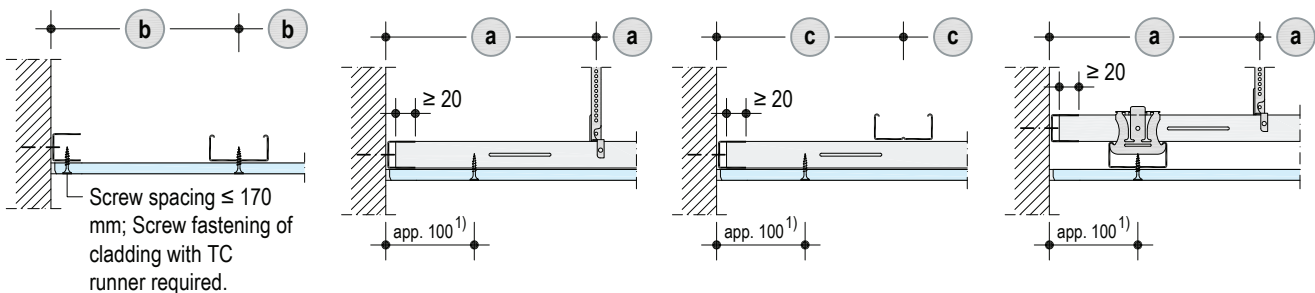



#### Legend

- a** Spacing of suspenders
- b** Axial spacing furring channel (cladding span width)
- c** Axial spacing carrying channel (spacing furring)

1) Maximum projection of the cladding

#### Suspenders

Dimensions in mm

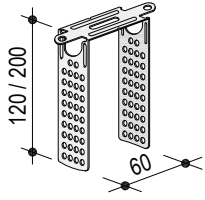
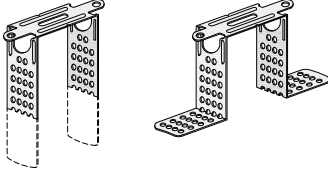
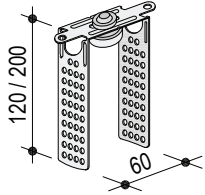
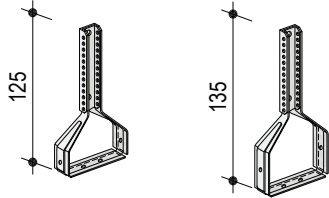
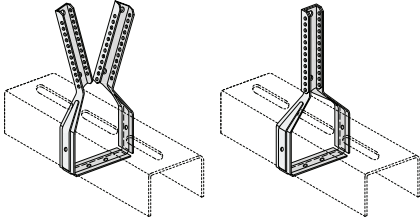
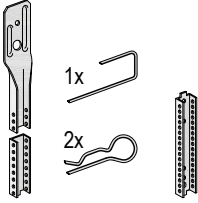
Suspension	Drawing	Comment
<b>0,25 kN (25 kg) load-bearing capacity class</b>		
<b>Ankerfix Basic</b> For TC 60/27 (0,6 mm)		 Anchoring to reinforced concrete ceiling with Knauf Ceiling Steel Dowels  Suspended with hanging wire
<b>0.40 kN (40 kg) load-bearing capacity class</b>		
<b>Universal brackets</b>		 Anchoring to reinforced concrete ceiling with suitable steel dowel at centre
<b>Damping universal bracket</b>		Bend or cut the universal bracket/ damping universal bracket according to the required suspension height, 2 x screw fix to CD 60/27  Anchoring to reinforced concrete ceiling with suitable steel dowel at centre
<b>Nonius stirrup</b> Height 125 mm: For TC 60/27 (0,6 mm)  Height 135 mm: For UA 50, For timber batten 50x30 (screw fix at side with SU 3.5x25)	    Bend Nonius stirrup around channel and fit together until it snaps in.	 Nonius hanger top and 1x Nonius pin or 2x Nonius bop pins  Anchoring to reinforced concrete ceiling with Knauf Ceiling Steel Dowels

**Note**

Anchoring to basic ceilings made of other building materials with specially approved or standardized anchoring elements.

### Construction heights

Dimensions in mm

The construction height of the ceiling results from the sum of suspenders, height of the grid and cladding thickness.

#### Calculation construction height

Construction height = suspenders height + grid height + cladding thickness

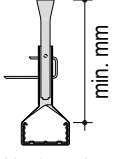
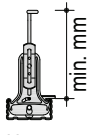
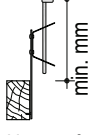
System	Suspenders with Nonius top			Grid	Total height mm
	Nonius strrup  Nonius stirrup	Rapid hanger  Hanger	Hanger for wood  Hanger for wood		
D111	-	-	110	15-180	50x30 + 50x30 50x30 + 40x60 60
D112	130	110	-	15-180	60x27 + 60x27 54
D116	130	-	-	-	UA 50x40 + TC 60x27 67

#### Calculation example

1	Height of the hanger D112 with Nonius suspender	130 mm
2	Carrying channel TC and furring channel TC	54 mm
3	Thickness of cladding	2x12,5 mm
4	Sum	209 mm

# D11.tr Knauf Board Ceilings

## Planning of joints recommendations

### Planning of joints

Observe the following criteria when planning movement and expansion joints:

- Use control joints in the case of ceiling areas exceeding approx. 10-15 m in length, e.g. for narrow ceiling spaces caused by a break of a wall.
- Should the free deformation be prevented, for example, by protruding solid components, the spacings must be reduced.
- Movement joints have to be transferred into the construction of the board ceilings.
- Separate connections of boards to components made of a different building material, especially columns, or thermally highly stressed built-ins such as lighting fixtures, for instance with shadow gaps.

### Examples with reduced free deformation

#### Expansion joints/movement joints

Hall ceiling with alcoves and protrusions – bay joints

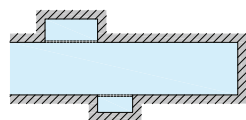

#### Protruding solid constructions

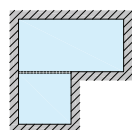

#### Protruding wall sections

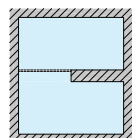

#### Deflection heads

Hall ceiling with alcoves and protrusions – circumferential deflection heads

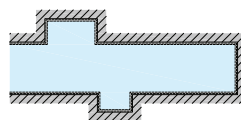

#### Suspended ceiling with recesses for columns

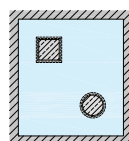

#### Anchoring of loads

Additional loads, e.g. lighting fixtures, curtain rails and similar can be fixed to board ceilings using proper dowel (expect when fire resistance is expected)

- Light loads:  
Point loads attached directly to the cladding may not exceed 6 kg per board and spacing between two furring channel can be max. 1 meter.
- Higher loads:  
Single loads attached to the frame may not exceed 10 kg per profile and metre. (for profile up to 1 meter long).

Existing demands on the fire resistance are subject to the following limitations: The attachment of additional loads (such as lighting fixtures) to the grid with a max. weight of 5 kg/m<sup>2</sup> and a maximum load of 10 kg per suspension point is permissible with suitable fasteners. Mounted elements with a weight up to 0.5 kg/m<sup>2</sup> (e.g. smoke detectors, motion sensors) may be attached to any position on the cladding

The following generally applies to the loads fastened to the cladding or the grid: These additional loads must be considered in the calculation of the self-weight of the board ceiling in acc. with the diagram on page 5.

Heavy loads must be anchored directly on load-bearing building elements (basic ceiling) or on auxiliary constructions

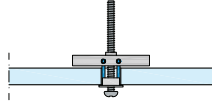
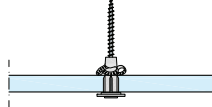
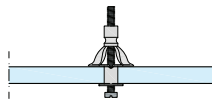
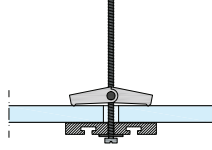
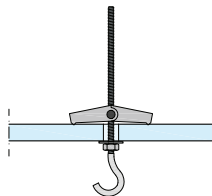
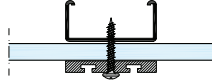
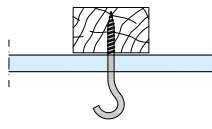
Fastening in the cladding	
Maximum of 6 kg per board span width and metre (with fire resistance maximum 0.5 kg per m <sup>2</sup> )	
	Knauf Hartmut Dowel Screw M5
	Plastic cavity dowel Ø 8 mm or Ø 10 mm
	Metal cavity Dowel Screw M5 or M6
	Spring toggle dowel e.g. curtain rail
	Spring toggle dowel e.g. roof suspension hooks
Fastening to the grid	
Maximum 10 kg per profile and meter (with fire resistance maximum 5 kg per m <sup>2</sup> )	
	Knauf Universal FN multi-purpose screw e.g. curtain rail
	Ceiling hook

### Details

1:5 ölçek (mm)

#### D111-A1 Connection to wall

Without fire resistance

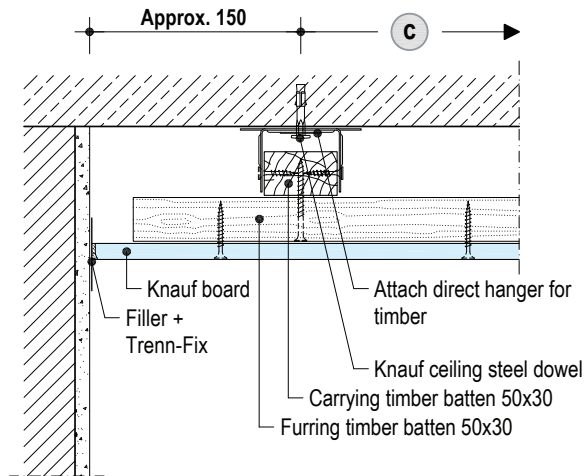

#### D111-D2 Connection to wall

Without fire resistance

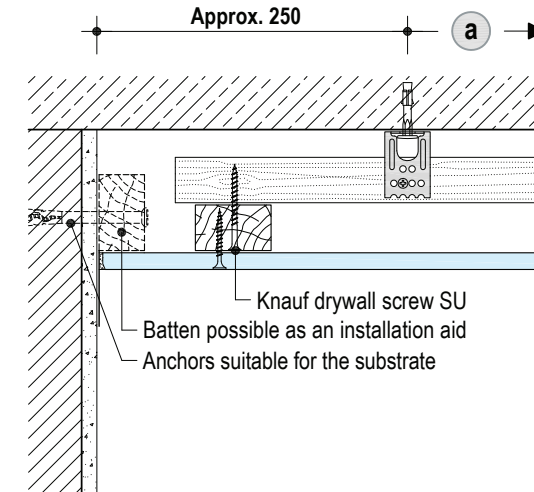

#### D111-B3 Longitudinal edge – Furring batten/Universal bracket

Without fire resistance

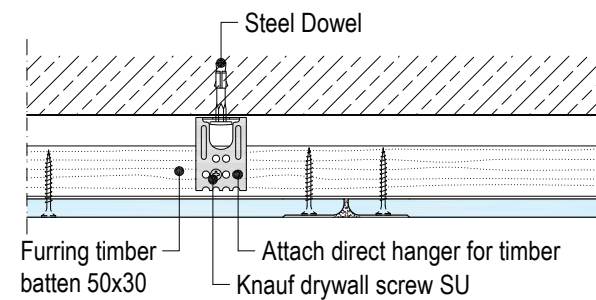

#### D111-C2 Front edge – Carrying channel/furring batten/ universal bracket

Without fire resistance

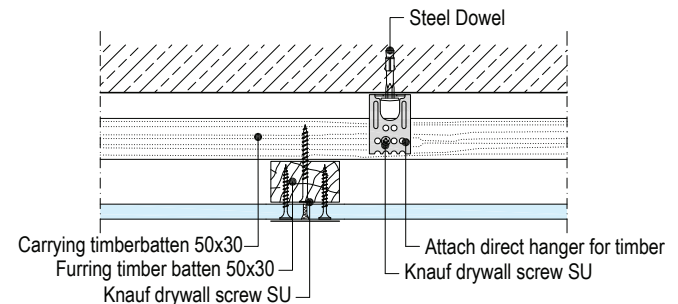

#### D111-B4 Longitudinal edge – Carrying channel/furring batten/ directly anchored

Without fire resistance

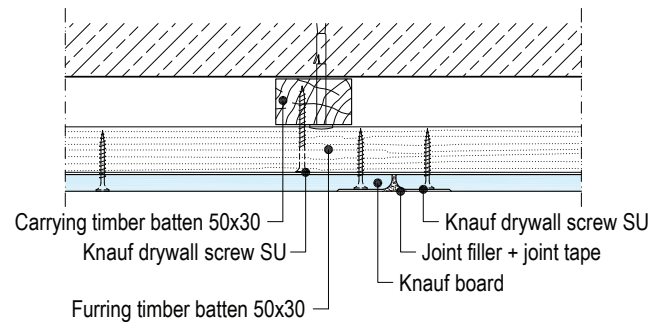

#### D111-C1 Front edge – Carrying channel/furring batten/directly anchored

Without fire resistance

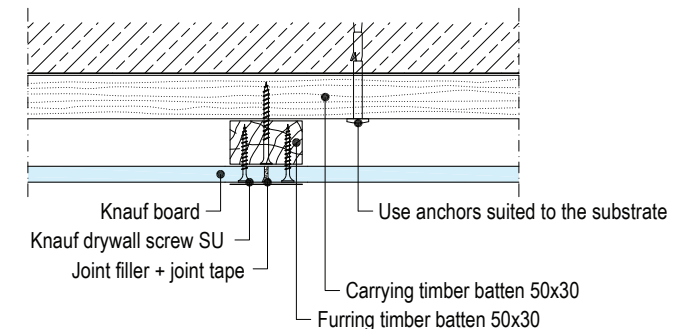

#### Details

Scale 1:5 in mm

#### D111-D1 Connection to wall gap

Without fire resistance

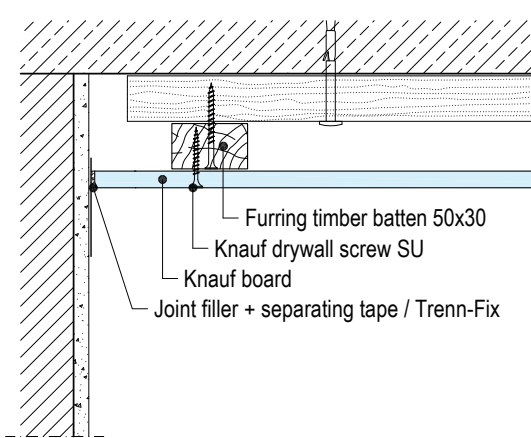

#### D111-D8 Connection to wall – shadow

Without fire resistance

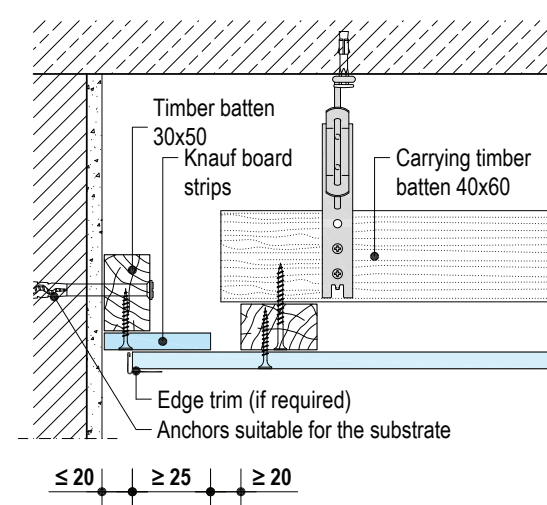

#### D111-B2 Longitudinal edge – Carrying channel/furring batten/rapid hanger

Without fire resistance

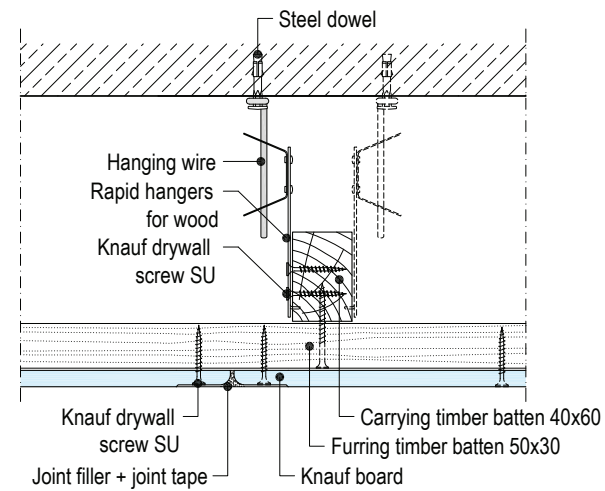

#### D111-C4 Front edge – Carrying channel/furring batten/rapid hanger

Without fire resistance

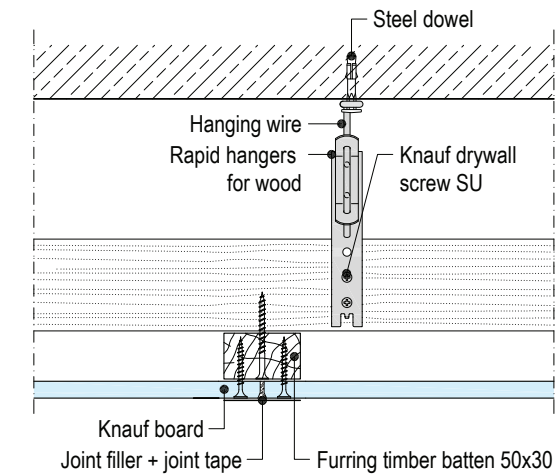

### Details

Scale 1:5 in mm

**D112-A2 Connection to wall**

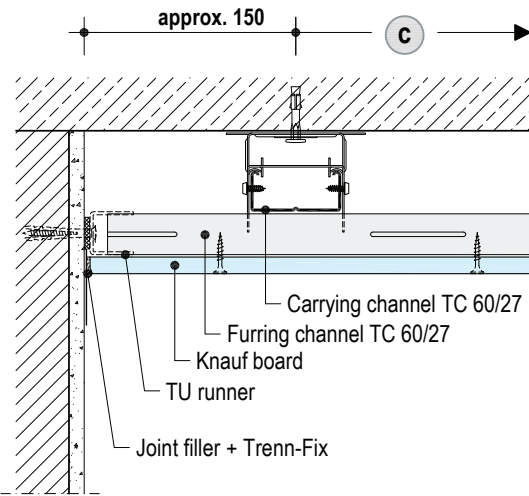

**D112-D2 Connection to wall**

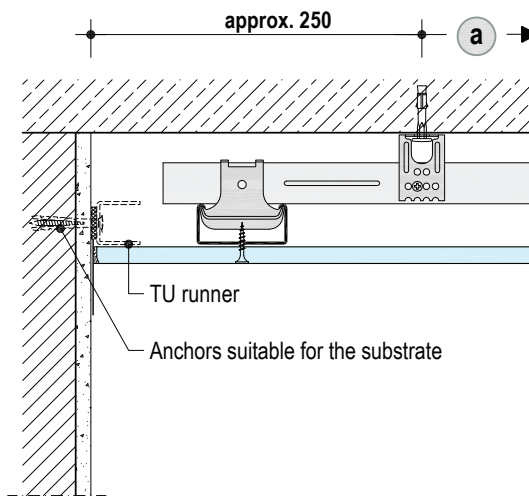

**D112-B2 Longitudinal edge – Carrying channel/furring channel/universal bracket**

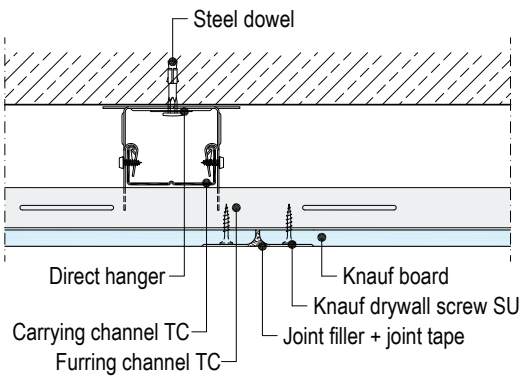

**D112-C2 Front edge – Carrying channel/furring channel/universal bracket**

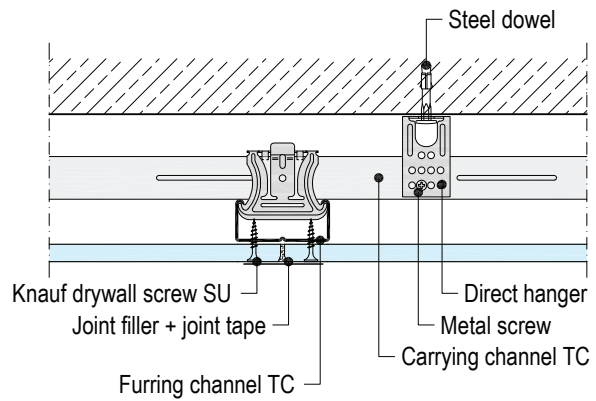

**D112-A1 Connection to wall**

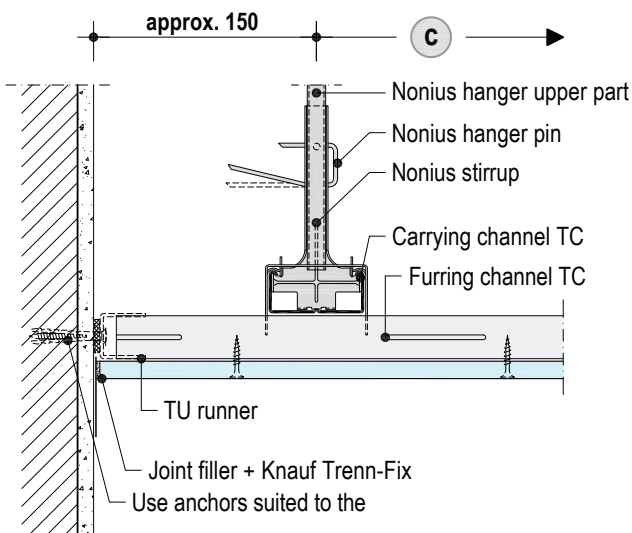

**D112-D3 Connection to wall**

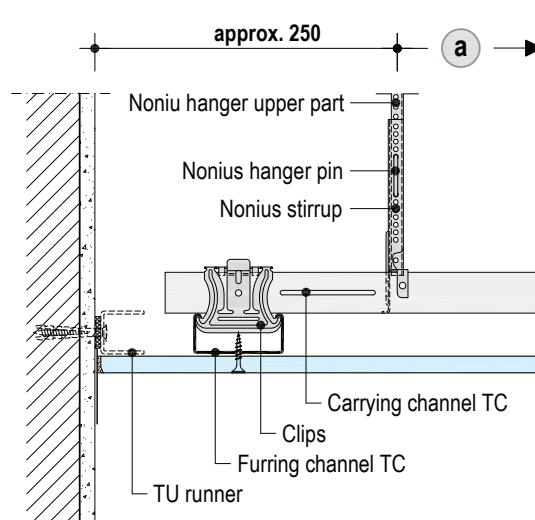

#### Details

Scale 1:5 in mm

#### D112-B4 Connection to wall

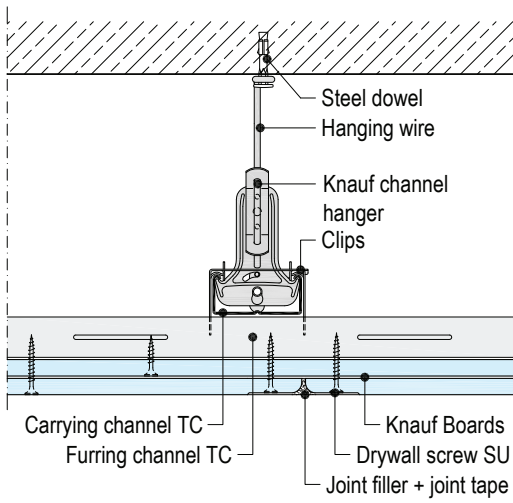

#### D112-C4 Connection to wall

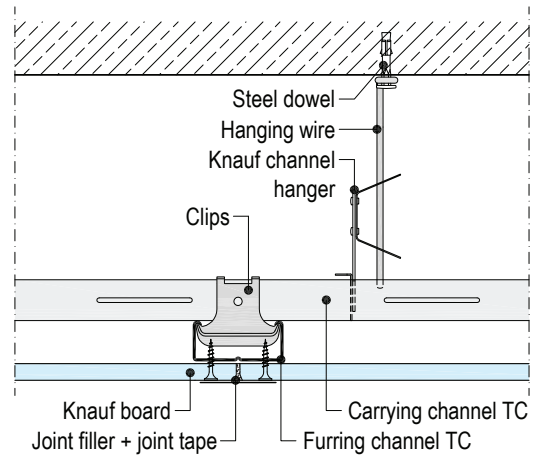

#### D112-B1 Longitudinal edge – Carrying channel/furring channel/Nonius stirrup

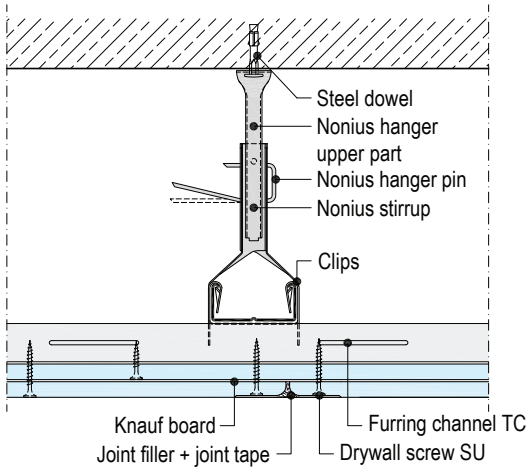

#### D112-C1 Front edge – Carrying channel/furring channel/Nonius stirrup

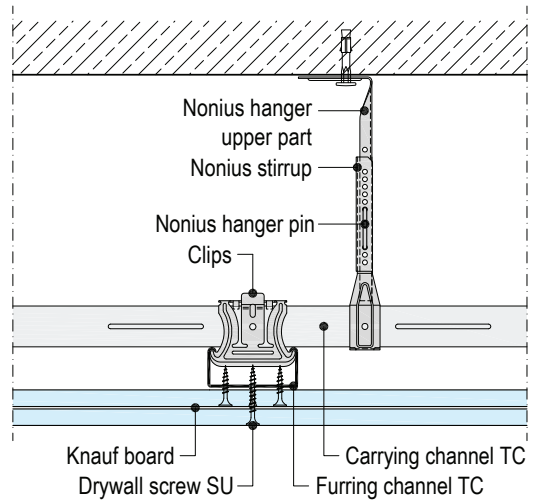

### Details

Scale 1:5 in mm

#### D112-A3 Connection to wall with face joint

Without fire resistance

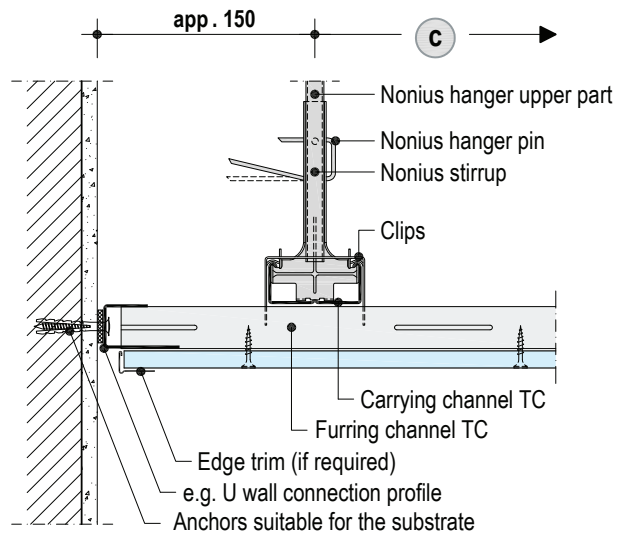

#### D112-D4 Connection to wall with shadow gap

Without fire resistance

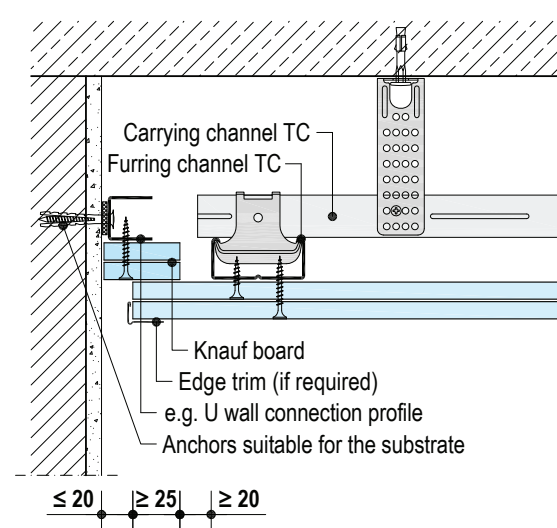

#### D112-B6 Connection of lightweight partition to ceiling

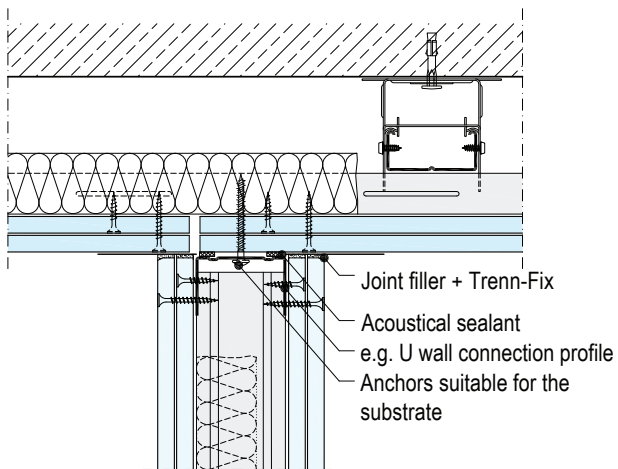

#### Details

Scale 1:5 in mm

#### D112-A5 Vertically sliding connection to wall

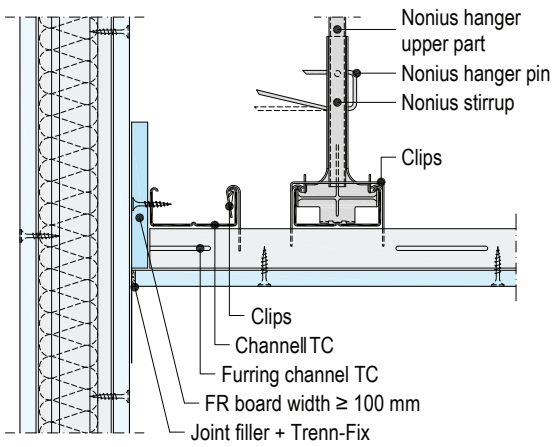

#### D112-D5 Vertically sliding connection to wall

Without fire resistance

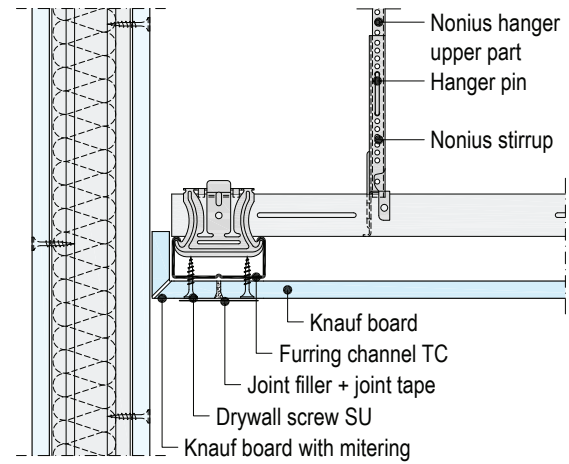

#### D112-D6 Sliding connection to wall

Without fire resistance

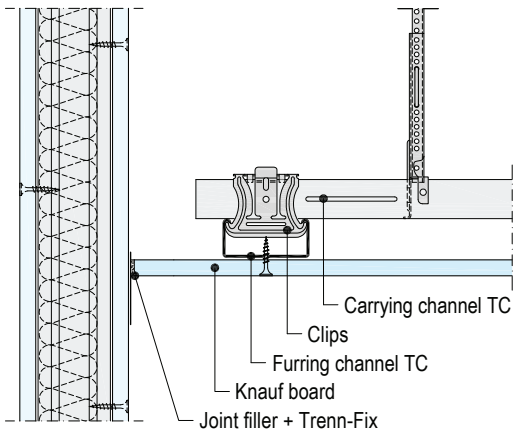

#### D112-D7 Sliding connection to wall

Without fire resistance

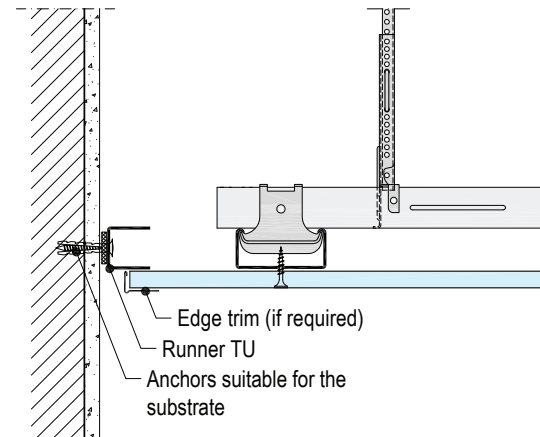

### Details

Scale 1:5 in mm

D116-A1 Connection to wall

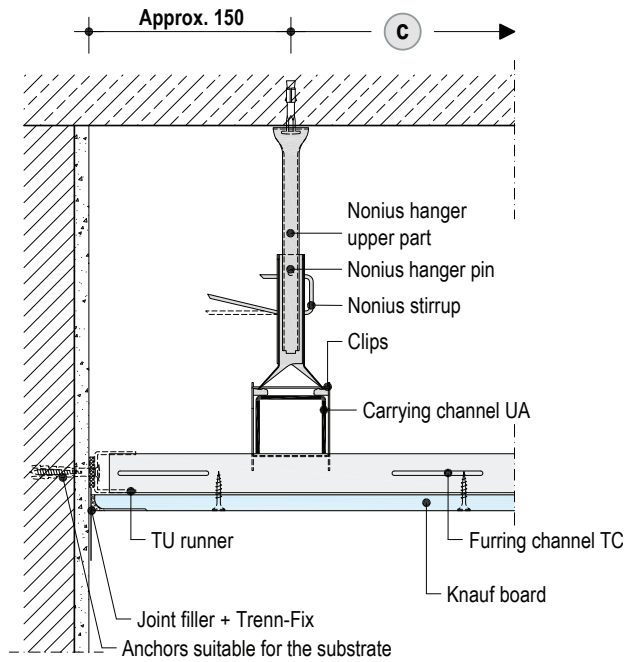

D116-D1 Connection to wall

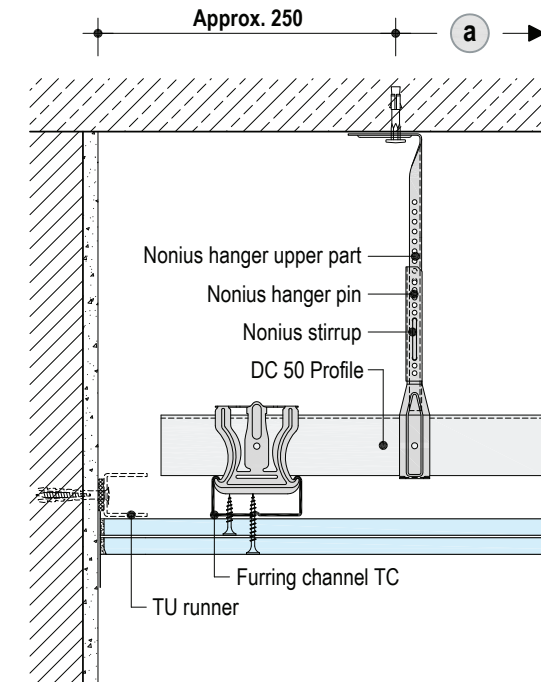

D116-B1 Longitudinal edge – Carrying channel/furring channel/Nonius stirrup

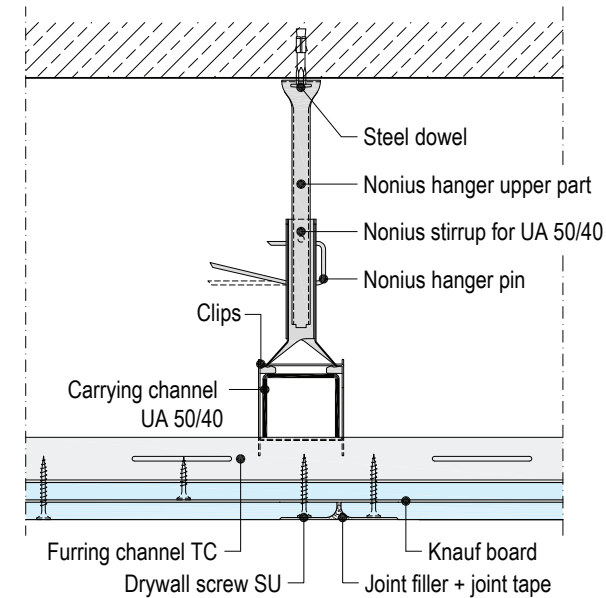

D116-C1 Front edge – Carrying channel/furring channel/Nonius stirrup

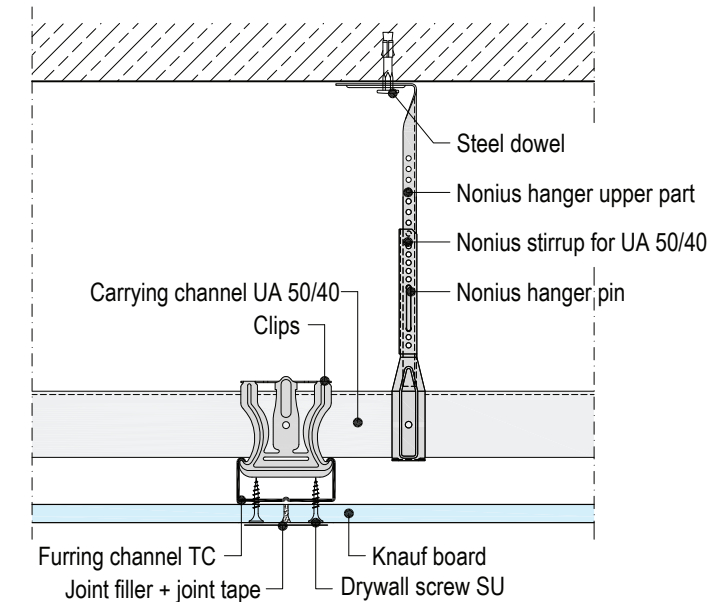

#### Movement joints

##### D111-C3 Movement joint

Without fire resistance

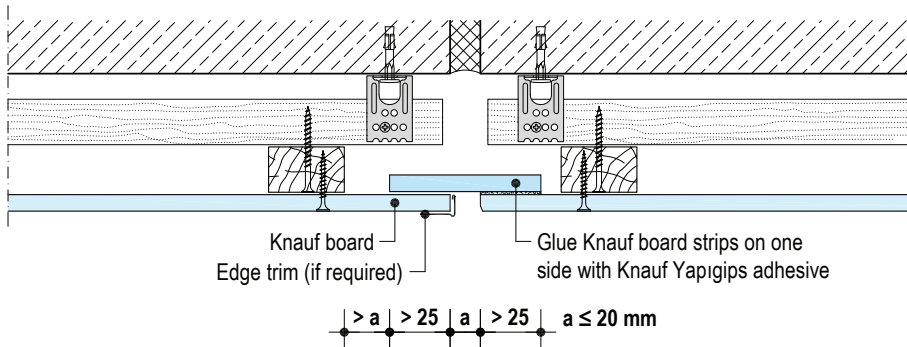

##### D112-C3 Movement joint

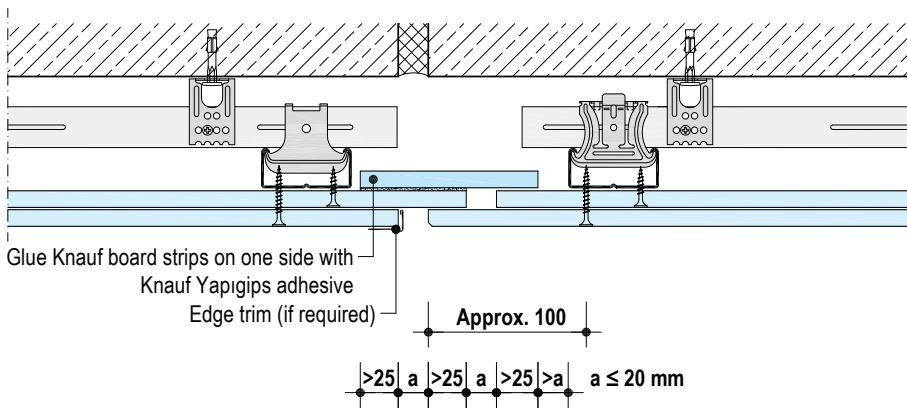

### Fire protection encasement of lighting fixtures

#### D112-SO10 Luminaire – Mitring – F30

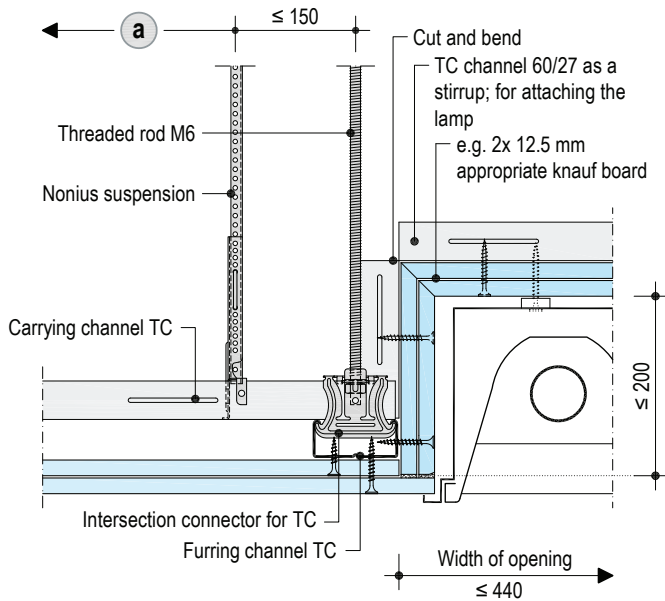

Contact with Knauf Technical Department for more info about fire resistance and also refer to Page 6.

#### D112-SO11 Luminaire – Encasement stapled – F90

Scale 1:5 in mm

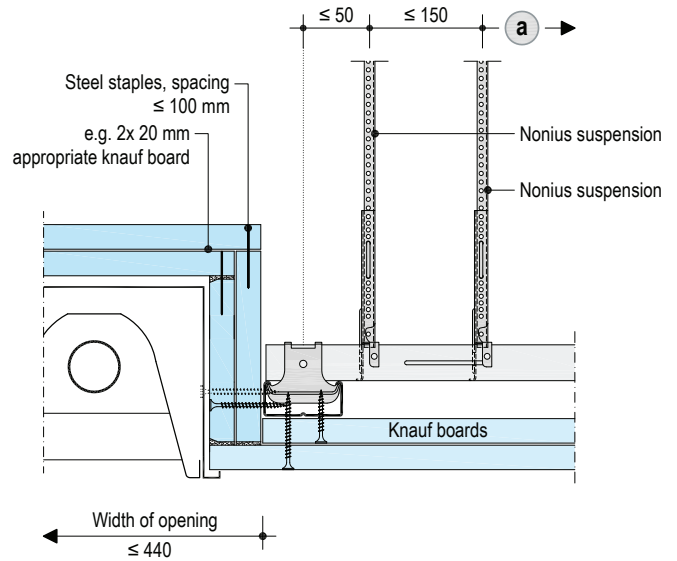

Contact with Knauf Technical Department for more info about fire resistance and also refer to Page 6.

- Permissible weight of the lighting fixture maximum 10 kg/unit (≈ 100 N/unit) and maximum 5 kg per m<sup>2</sup> of ceiling surface.
- Fastening of the lighting fixtures to the ceiling grid or to the TC channel stirrup.
- Additional profile TC 60/27 (0,6 mm) for perimeter (also on the front ends of the fire resistance encasement).
- Maximum dimension 440x1420 mm (outer edge of fire resistance encasement)

#### Ceiling bulkhead D112-SO14 Ceiling bulkhead

Scale 1:5 in mm

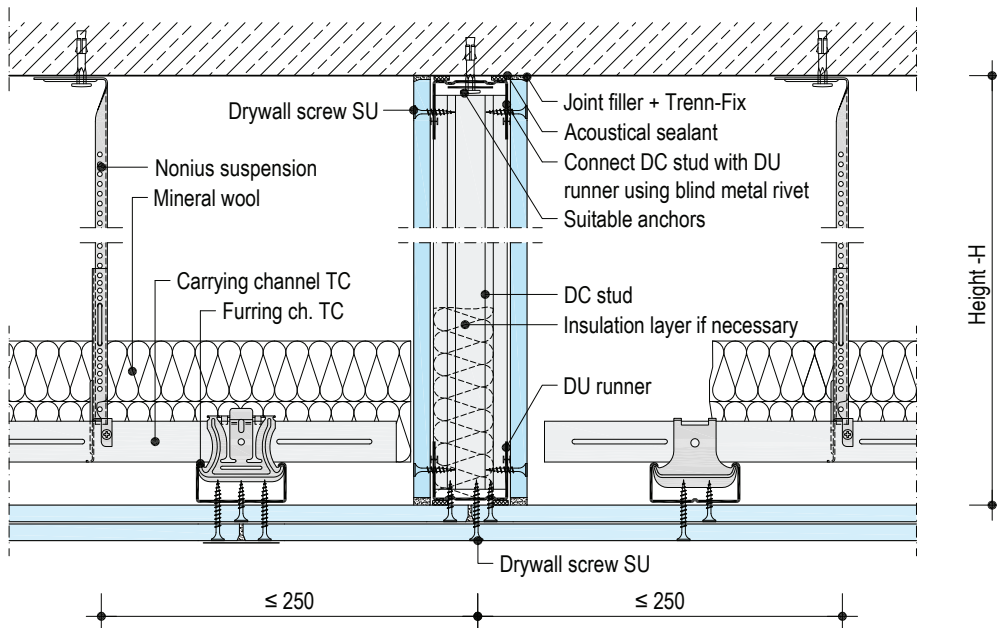

Contact with Knauf Technical Department for more info about fire resistance and also refer to Page 6.

#### D112-SO15 Ceiling bulkhead

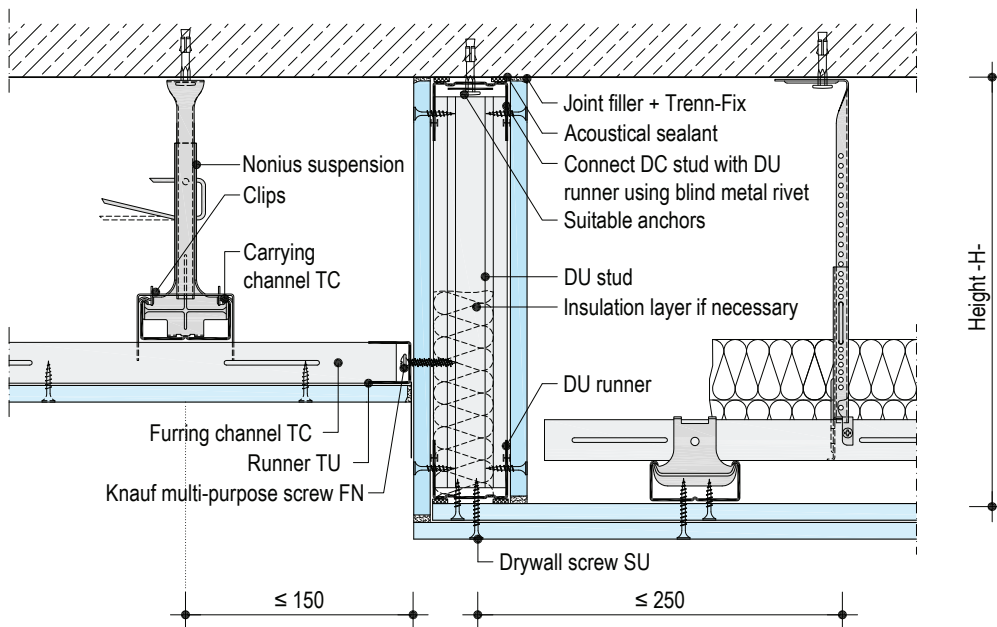

Contact with Knauf Technical Department for more info about fire resistance and also refer to Page 6.

- For maximum height -H- of the ceiling bulkhead contact with knauf technical department.
- Fixing of the ceiling bulkhead to the basic ceiling with suitable anchors  $a \leq 1000$  mm.

### Split level ceiling

#### D112-SO16 Split level ceiling 45°

Scale 1:5 in mm

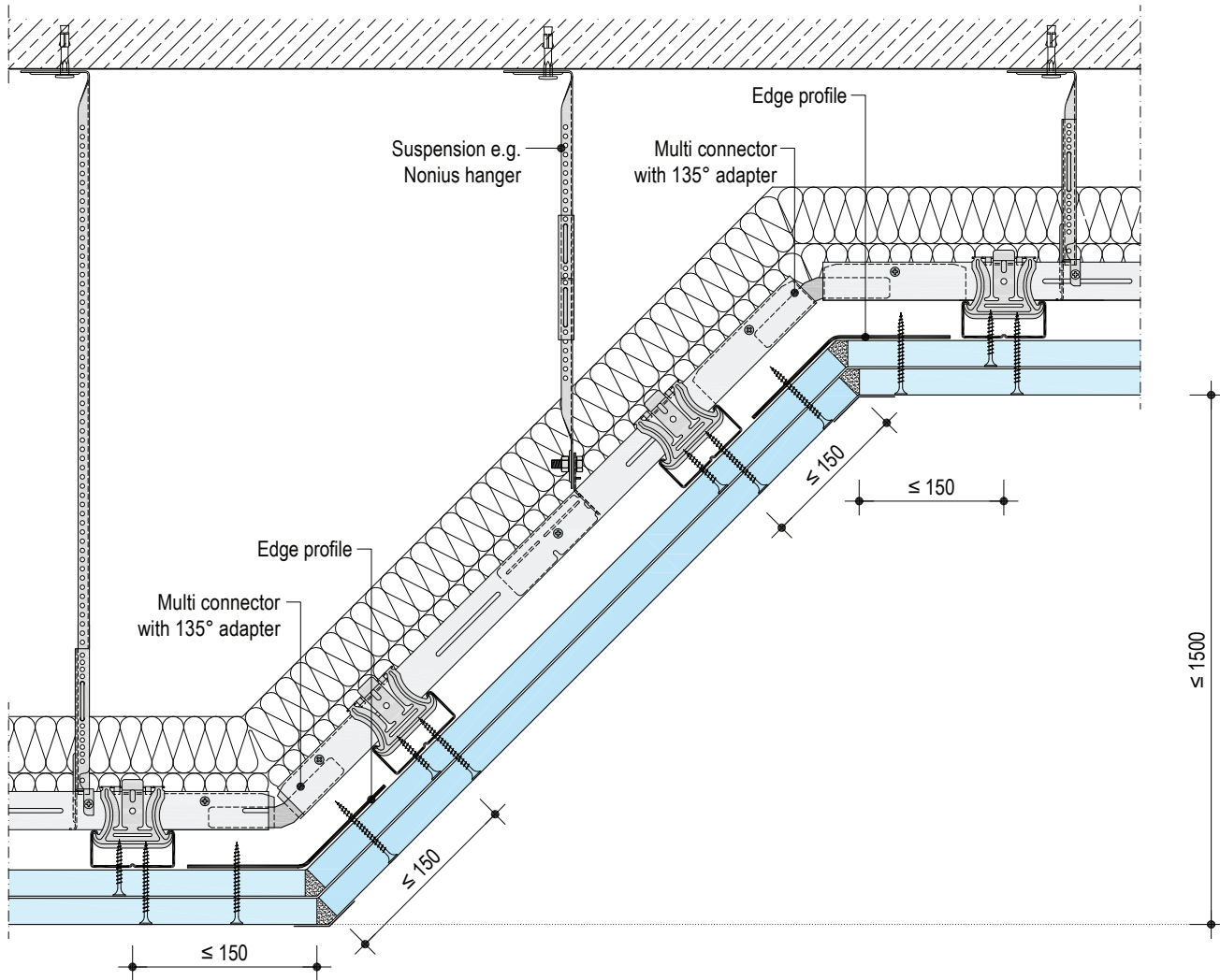

Contact with Knauf Technical Department for more info about fire resistance and also refer to Page 6.

#### Split level ceiling

Scale 1:5 in mm

#### D112-SO17 Split level ceiling 90°

Fire protection solely from below

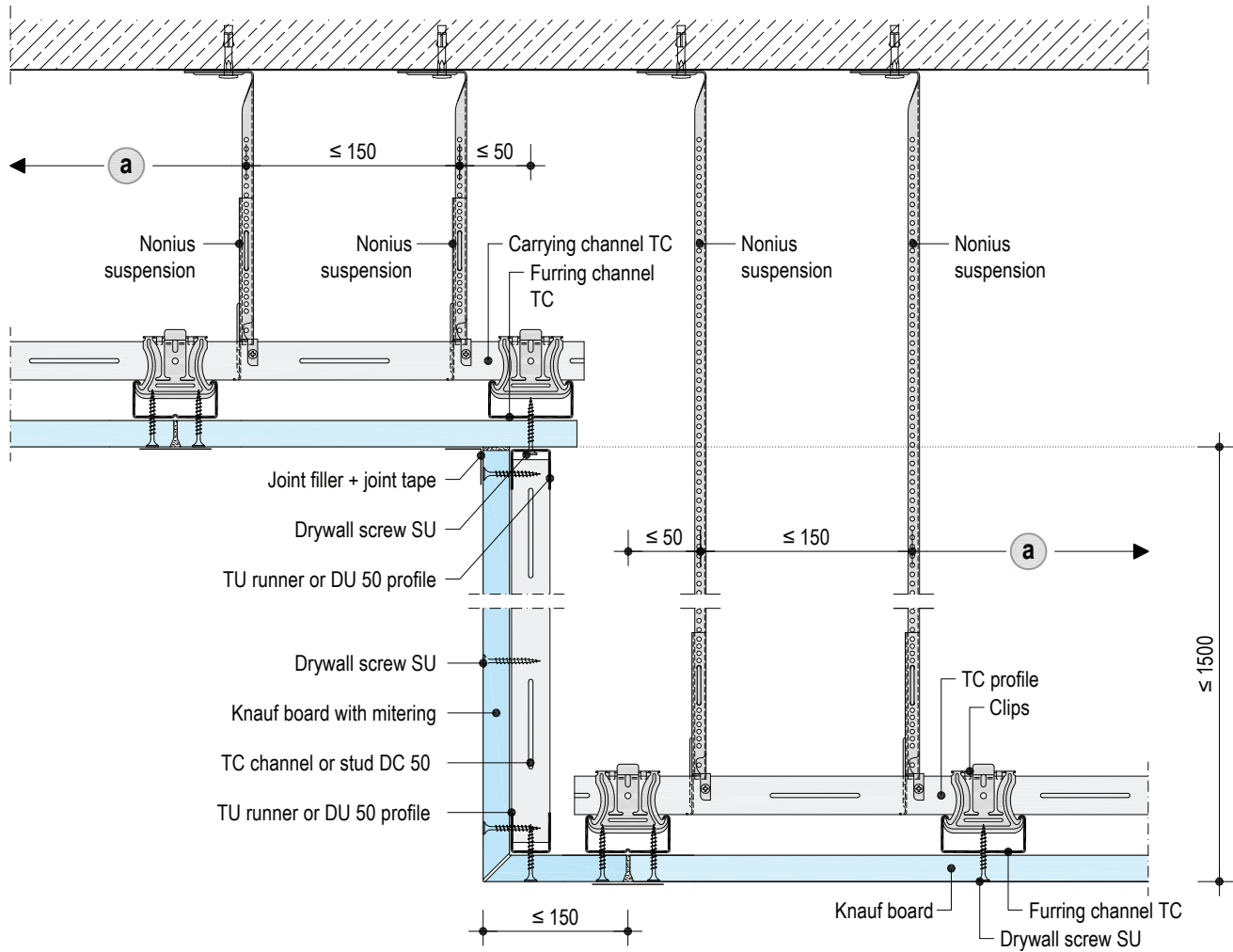

Contact with Knauf Technical Department for more info about fire resistance and also refer to Page 6.

### Knauf alutop access panel ceiling

Scale 1:5 in mm

#### Vertical sections

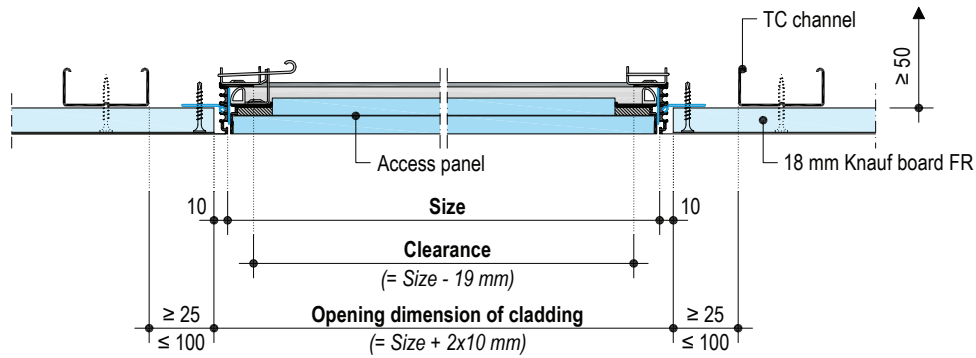

#### Plan

D112 suspended ceiling

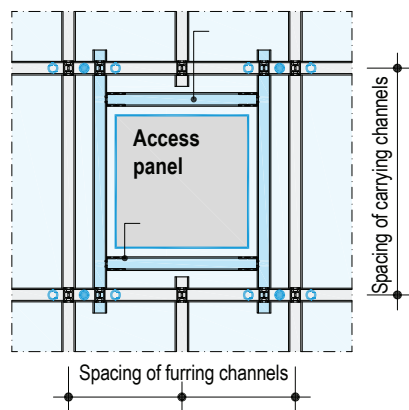

Installation without trimmer: With access panels 300x300 mm

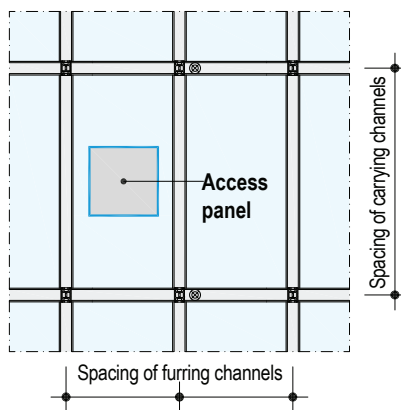

#### Legend

	Additional grid
	Additional suspension points
	Alternative suspension points

#### Knauf alutop access panel

Scale 1:5 in mm

##### Vertical section

Without fire resistance

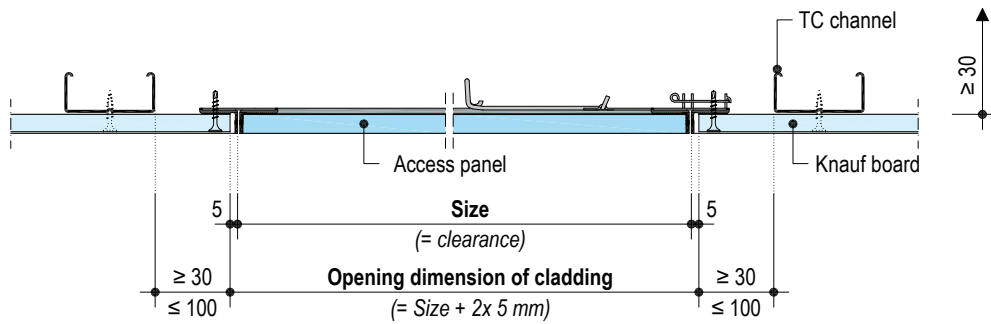

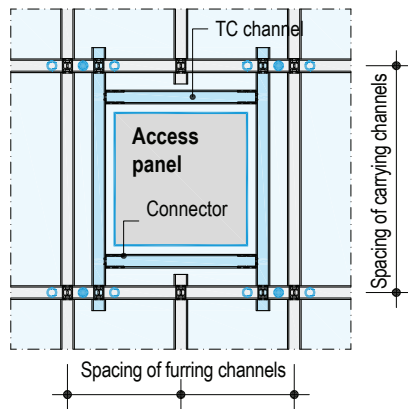

##### Plan

D112 Suspended ceiling



##### Legend

	Additional grid
	Additional suspension points
	Alternative suspension points

### Lightweight partitions to be connected from below to fire resistant classified ceiling systems

Technical fire resistance classified ceiling systems (suspended ceilings) may only be connected to partitions when it is assured in the event of a fire, that should the partition be destroyed prematurely, the remaining elements can collapse without creating an additional load to the ceiling.

The connection can be applied as indicated below.

**Note**

Should there be fire protection requirements for the connected partition, the suspended ceiling alone must feature at least the same fire resistance class.

### Design of the connections

#### Fire exposure solely from below

On suspended ceilings with fire resistance from below, the connection to the ceiling must be implemented without screw fixing to the DU profile, but the cladding must extend up to the suspended ceiling.

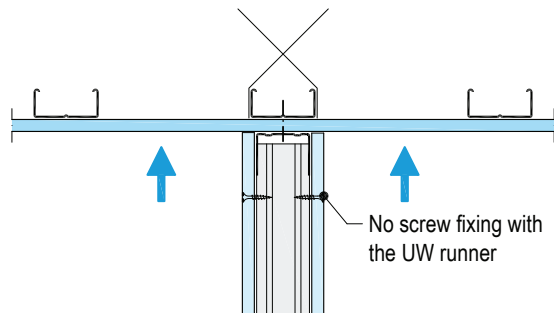

#### Fire exposure solely from above

On suspended ceilings with fire resistance from above, implement a deflection head in a standard design with at least 15 mm freedom of movement.

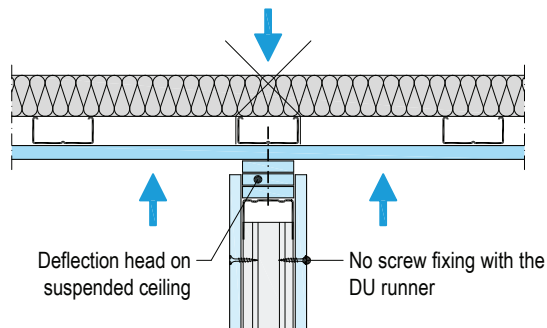

#### Suspended ceilings in conjunction with basic ceilings of types I to III

For suspended ceilings in conjunction with basic ceilings of types I to III, the stated fire resistance class only applies for the entire ceiling system (a). Implement ceiling connection of partitions without fire resistance without screw fastening to the DU runner.

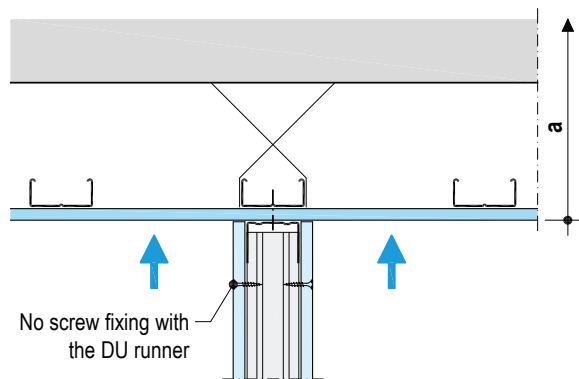

If partitions with fire protection requirements are connected to the suspended ceiling, the classification of the suspended ceilings alone must at least be the same fire resistance class as the partition.

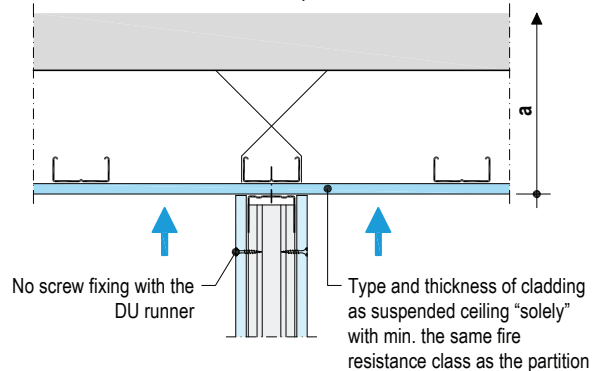

Partitions with the same fire resistance class as the entire ceiling system (a) must be fastened to the basic ceiling.

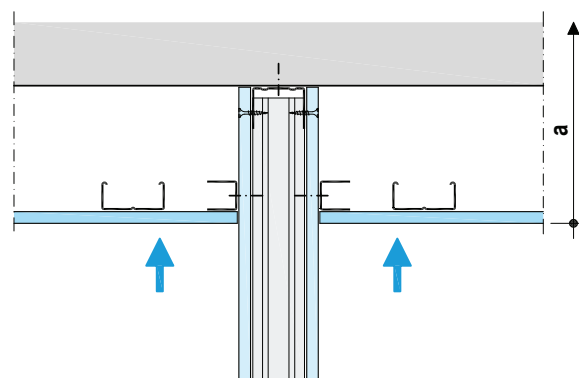

Contact with Knauf Technical Department for more info about fire resistance and also refer to Page 6.

#### Bracing

Non-load-bearing interior partitions can be connected to the suspended ceiling system provided that they are braced sufficiently. The bracing can be implemented locally by arranging slotted steel strap suspenders in the suspender area or by load transfer via the ceiling diaphragm to the flanking partitions connected to the basic ceiling.

With door build-ins, the cladding thickness of the suspended ceiling  $\geq 15$  mm Diamant or  $\geq 18$  mm Knauf boards, load transfer preferably by transfer to the flanking partitions connected to the basic ceiling.

The loads should be transferred directly to the basic ceiling on walls with built-in sanitary accessories.

#### Horizontal bracing via load transfer

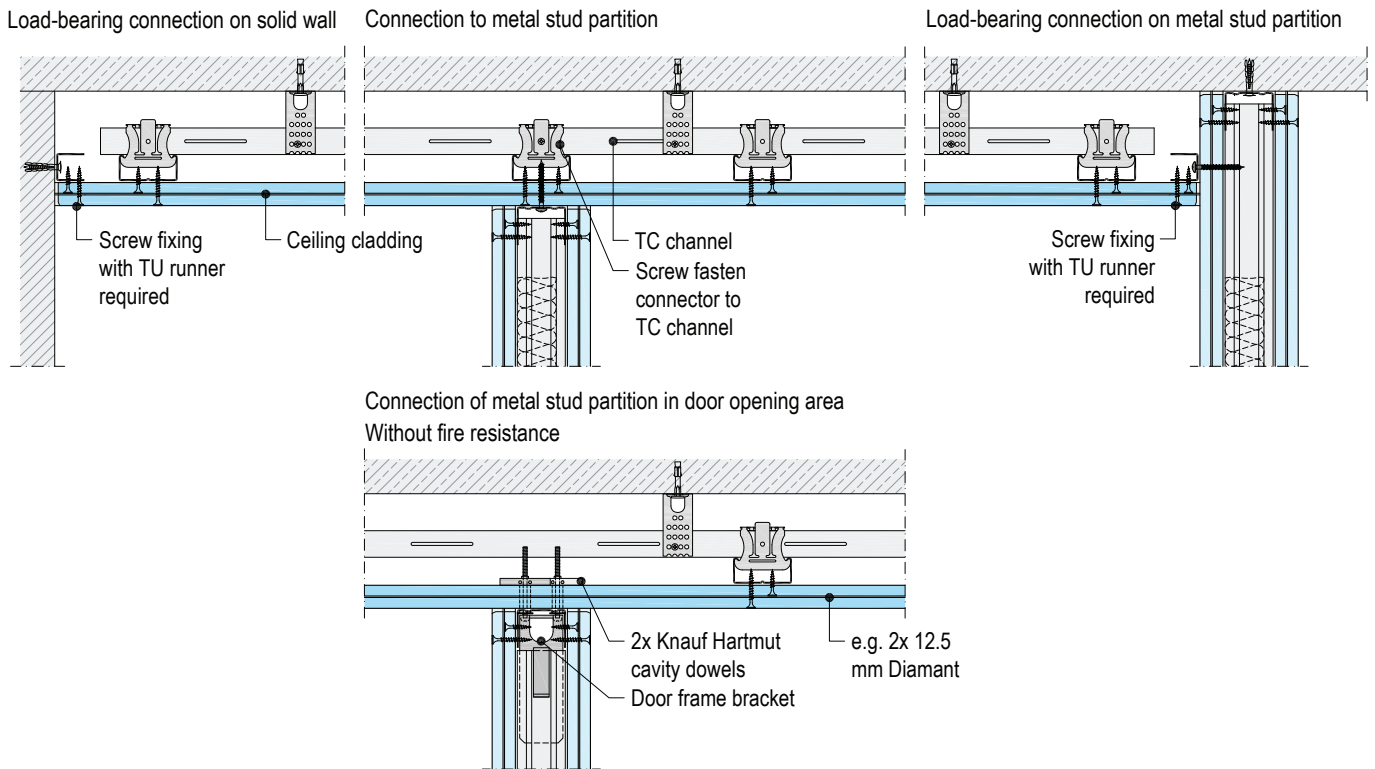

#### Horizontal bracing by diagonal bracing

Diagonal bracing in the suspended area

Spacing  $\leq 800$  mm (angle  $\leq 45^\circ$ )

Permissible wall height  $\leq 4$  m

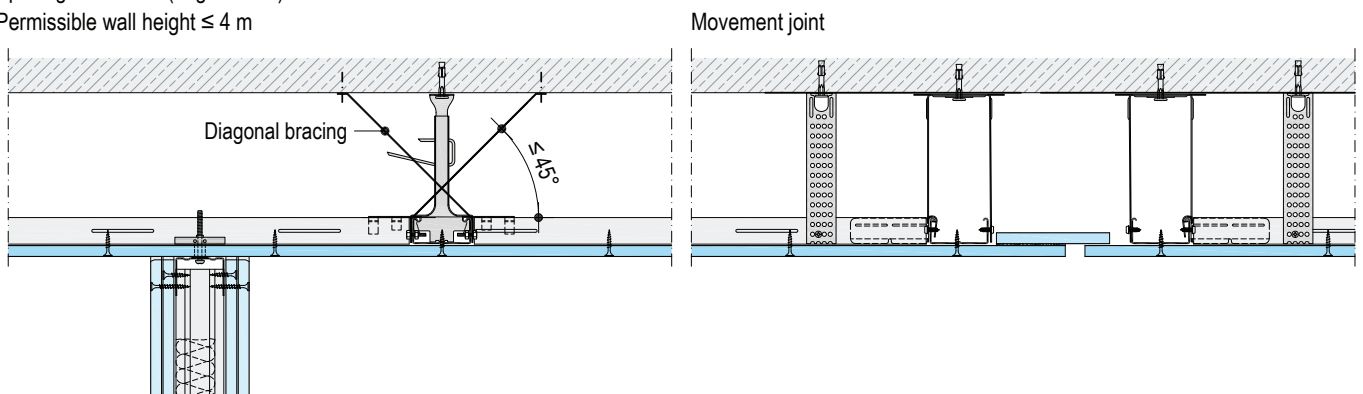

### Lateral connection of technical fire resistance classified ceiling systems to technical fire resistance classified partitions

Suspended ceilings in conjunction with basic ceilings of types I to III as well as solely suspended ceilings with fire resistance from below and/or from above, that comply with fire resistance classes F30 to F90, can be connected to partitions if they also have at least the same fire resistance class. The partition substrate in the connection area must be even. If necessary, measures to level it will be required. The connection to the suspended ceiling must be sealed and backed.

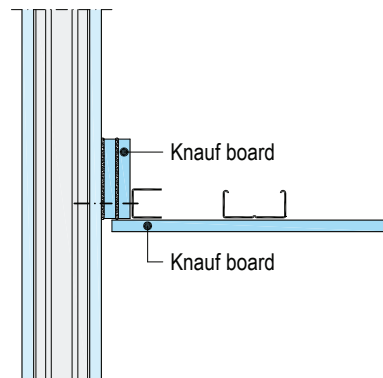
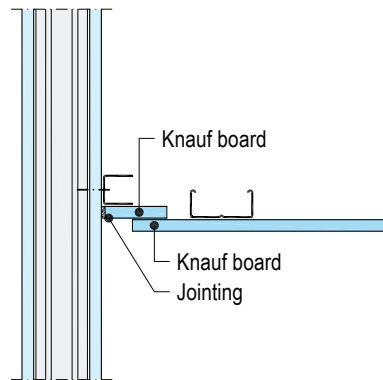
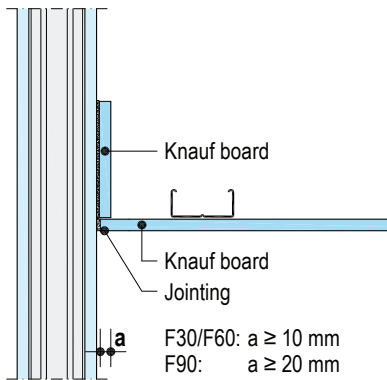
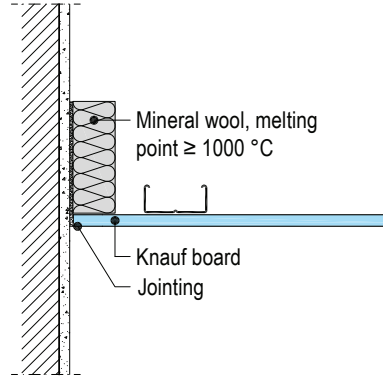
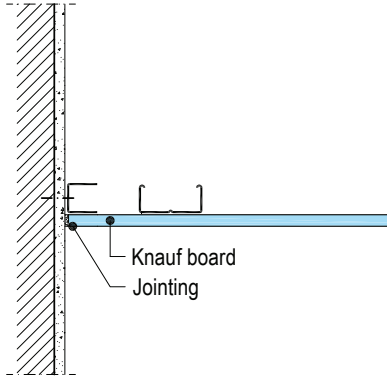

Contact with Knauf Technical Department for more info about fire resistance and also refer to Page 6.

#### Additionally necessary constructional measures with fire resistance from above (from the plenum)

##### Anchoring to the reinforced concrete basic ceiling

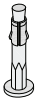

Use fire protection approved anchors  
**Knauf Ceiling Steel Dowels**

##### Nonius hanger

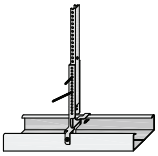

Screw fasten the tabs to the TC (2x metal screws)

#### Insulation layer

##### D112 Metal grid

Single-layer insulation, with covering strip on the carrying channel

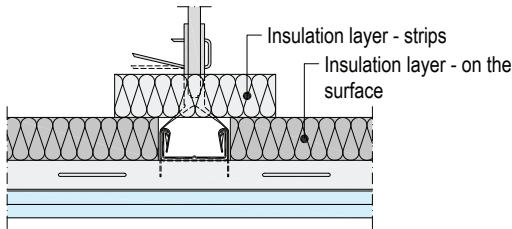

##### Double-layer insulation

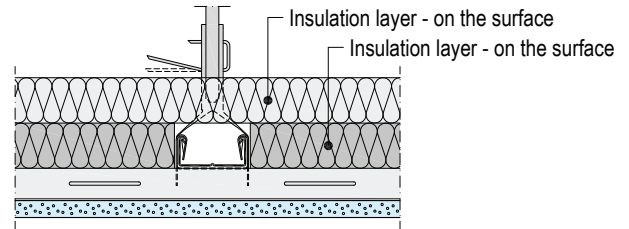

##### D116 Large-span metal grid

Single-layer insulation, with covering strip on the carrying channel

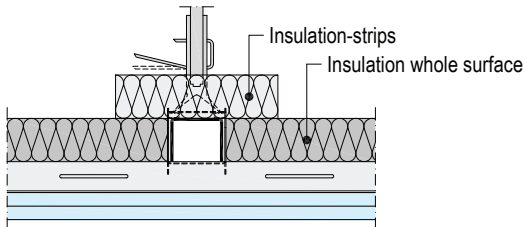

##### Double-layer insulation

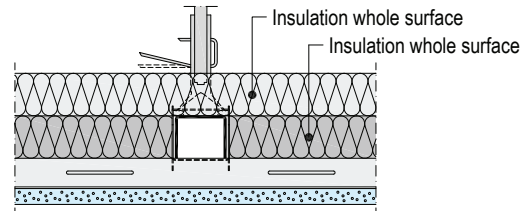

#### Note

Type, thickness and density of the insulation layer in acc. to specifications of the respective system variants.

### Exposed ceiling under fire protection ceiling

Dimensions in mm

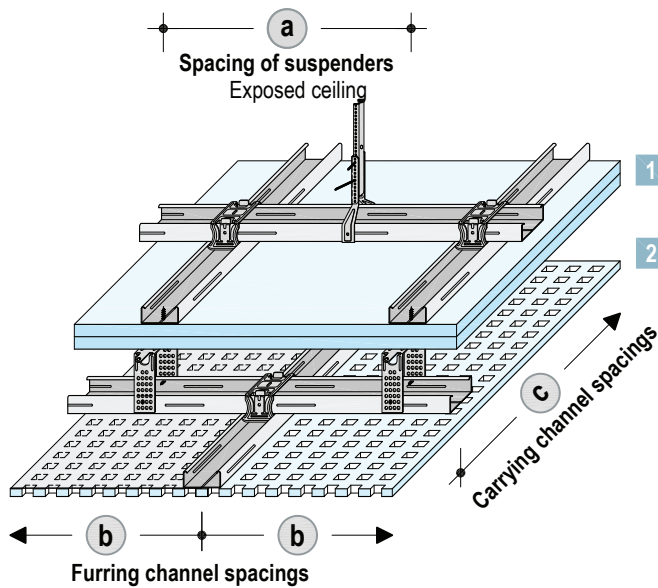

#### Legend

- 1 Fire protection ceiling
- 2 Exposed ceiling

#### 1 Axial spacings fire protection ceiling protection ceiling

The additional load of the suspended ceiling (exposed ceiling  $\leq 0.15 \text{ kN/m}^2$ ) must be considered with the grid of the fire protection ceiling, see also page 5

Dimensioning of the grid.

The spacings of the fire protection ceiling grid result from the specifications of the respective system ceilings taking the additional weight of the exposed ceiling into consideration.

#### 2 Maximum spacings of exposed ceiling

Axial spacings carrying channel c	Spacings of suspenders <sup>1)</sup> Load class in $\text{kN/m}^2$ $\leq 0,15$	Axial spacings Furring channel b
800	800 <sup>2)</sup>	500
1000	400/500	(for Cleaneo Acoustic ceilings, see D127)
1200	400/500	

1) Suspension must be fastened to the furring channels of the fire protection ceiling.

2) With furring channel axial spacing 400 mm (fire protection ceiling), attach alternately to every second furring channel of the fire protection ceiling. With furring channel axial spacing 500/600 mm (fire protection ceiling), attach to every furring channel of the fire protection ceiling.

### Detail

#### Front edge – Multi-level ceiling system

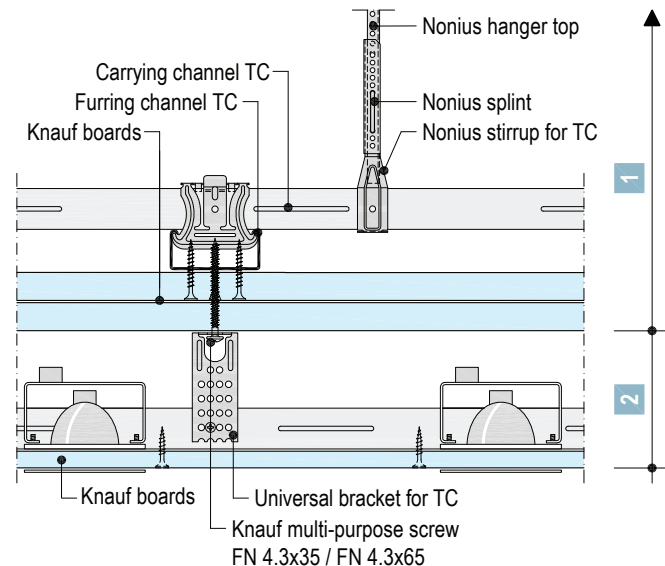

Alternative:

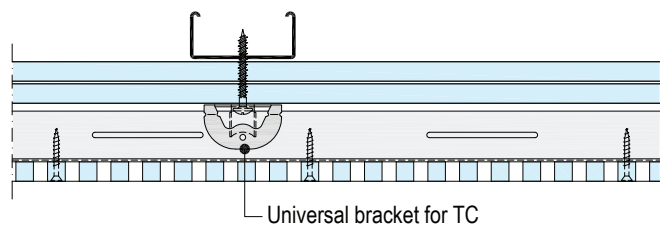

#### Extension of the fire resistance certificate of usability

- Multi-level ceiling system design Prior consultation in acc. to Page 6 is recommended.

#### Note

Always apply suspended channels of exposed ceiling lateral to furring channel of the fire protection ceiling. Load of exposed ceiling per suspension point maximum 100 N. with exposed metal ceiling suspension height min. 150 mm.

#### Cladding installation

- Commence with the fixing of the boards in the board centre or on the board corner to avoid buckling.
- Every board layer should be pushed firmly onto the grid and attached as an independent layer.

#### Installation schemes

Dimensions in mm

##### Knauf boards – lateral cladding application <sup>1)</sup>

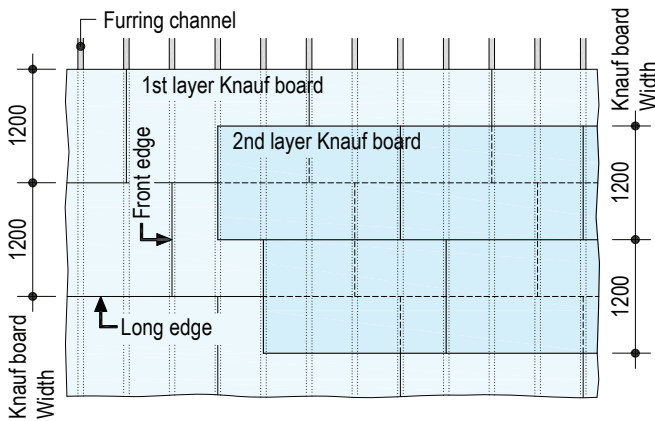

##### Board width:

- 1st layer: 1200 mm
- 2nd layer: 1200 mm

- Apply Knauf boards lateral to the furring timber batten/furring channel.
- Arrange the board joints on the furring timber batten/furring channels (stagger by at least 400 mm).
- Stagger by at least 400mm the front edge joints between board layers.
- Stagger the long joints between the board layers by at least half a board width.

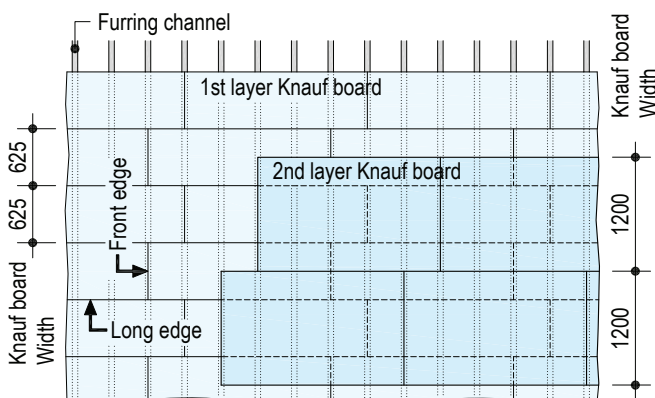

##### Board width:

- 1st layer: 625 mm örn. Knauf Silentboard
- 2nd layer: 1200 mm Diamant®

- Apply Knauf boards lateral to the furring timber batten/furring channel.
- Arrange the board joints on the furring timber batten/furring channels (stagger by at least 400 mm).
- Stagger the front edge joints between board layers.
- Stagger the long joints between the board layers by at least half a board width to the 1st layer.

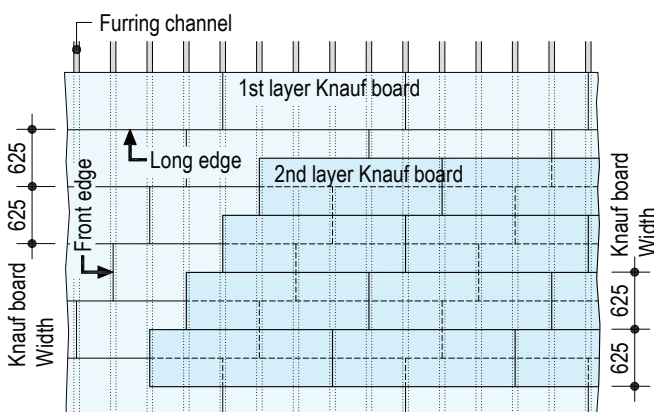

##### Board width:

- 1st layer: 625 mm örn. Knauf Silentboard
- 2nd layer: 625 mm örn. Knauf Silentboard

- Apply Knauf boards lateral to the furring timber batten/furring channel.
- Arrange the board joints on the furring timber batten/furring channels (stagger by at least 400 mm).
- Stagger the front edge joints between board layers.
- Stagger the long joints between the board layers by at least half a board width.

<sup>1)</sup> Board direction should be applied vertically. TS 1475-3 should be considered for lateral applications.

### Installation of grid

#### Anchoring to basic ceilings

Anchoring of the suspension must be undertaken using anchors suitable for the substrate:

- Made of reinforced concrete: Suitable steel dowel
- Made of other building materials: Specially approved or standardized anchoring elements for the building material.

With fire resistance from above use fire protection approved anchor (Knauf ceiling steel dowel).

#### Suspension

Suspension of the carrying and furring channels exclusively with suspenders acc. to pages 35.

Refer to the system tables in the "Data for planning" section for the anchoring spacings on ceilings and profiles/batten spacings.

#### Profiles

Carrying timber battens/profiles or furring timber battens/profiles must be connected with suspenders and aligned flush in the required suspension height.

- Stagger all profile joints
- Profile extensions of the furring channel TC with TC longitudinal connector.

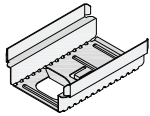

Implement the longitudinal joints of the carrying channels (profile extensions) as follows:

- Carrying channel TC with TC longitudinal connector

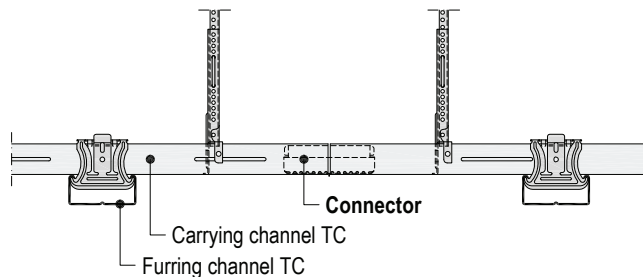

- Carrying channel UA with DU runner (D116)

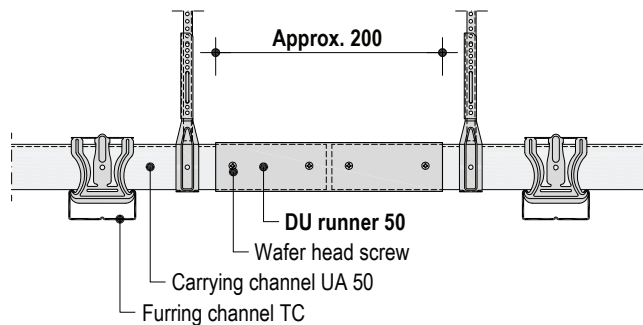

- The connection of the carrying and furring channel at the intersection points for configurations with double profile grid / batten frame is in accordance with the system in the table on page 63.

#### Connection to wall

With profile UD as a load-bearing connection, installation aid or with fire resistance.

Anchoring to the substrate with suitable fasteners/anchors, spacing max. 1 m (non-load-bearing) or 600 mm (load-bearing).

In case of sound insulation requirements, seal carefully with acoustical sealant.

#### Caution

In addition to the application and detail information in this brochure;

The information in the "TS 1475-3 GYPSUM PLASTERBOARD APPLICATIONS - PART 3: SUSPENDED CEILING APPLICATION RULES" standard must be taken into account.

#### Timber batten/profile connections

Scheme drawings

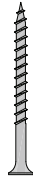
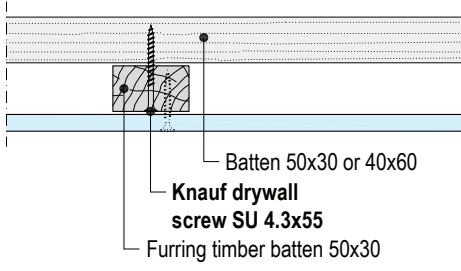
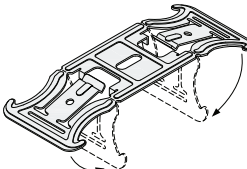
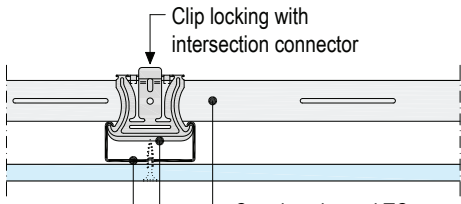
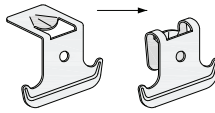
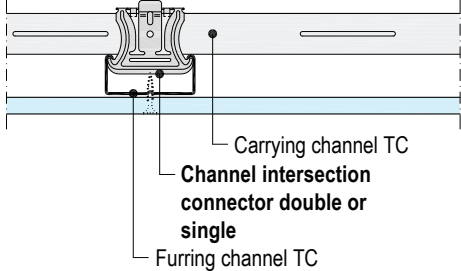
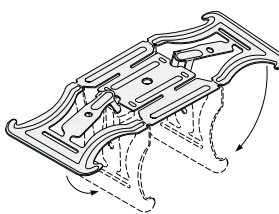
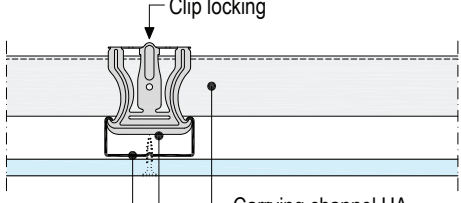
Description	Connection	Detail
<b>D111 Connection carrying channel and furring channela</b>		
Drywall screw SU 4,3x55		 <p>Batten 50x30 or 40x60 Knauf drywall screw SU 4.3x55 Furring timber batten 50x30</p>
<b>D112 Connection carrying channel TC and furring channel TC</b>		
Intersection connector for TC ■ Before installation, bend to 90° and after installation close the clip lock to ensure a secure hold.		 <p>Clip locking with intersection connector Carrying channel TC Channel intersection connector double or single Furring channel TC</p>
Alternative: 2x Ankerwinkel Clips for TC ■ Bend for installation.		 <p>Clip locking Carrying channel UA Intersection connector for UA Furring channel TC 60/27for UA</p>
<b>D116 Connection carrying channel UA and furring channel TC</b>		
Intersection connector for UA profile ■ Before installation, bend to 90° and after installation close the clip lock to ensure a secure hold.		 <p>Clip locking Carrying channel UA Intersection connector for UA Furring channel TC 60/27for UA</p>

**Caution**

In addition to the application and detail information in this brochure;  
 The information in the “TS 1475-3 GYPSUM PLASTERBOARD APPLICATIONS - PART 3: SUSPENDED CEILING APPLICATION RULES” standard must be taken into account.

### Fastening of the cladding

Dimensions in mm

Cladding  Thickness	Metal stud frame (Penetration $\geq 10$ mm) Metal gauge $s \leq 0,7$ mm		Wood frame (Penetration $\geq 5 d_n$ )	
	Knauf board screw <b>SU</b>	Knauf Diamant® screw <b>HGP</b>	Knauf board screw <b>SU</b>	Knauf Diamant® screw <b>HGP</b>
12,5	SU 3,5x25	HGP 3,9x23	SU 3,5x35	HGP 3,9x38
15	SU 3,5x25	HGP 3,9x38	SU 3,5x35	HGP 3,9x38
18 / 20 / 25	SU 3,5x35	–	SU 3,5x45	–
2x12,5	SU 3,5x25 + SU 3,5x35	HGP 3,9x23 + HGP 3,9x38	SU 3,5x35 + SU 3,5x45	HGP 3,9x38 + HGP 3,9x55
2x15	SU 3,5x25 + SU 3,5x45	–	–	–
2x20	SU 3,5x35 + SU 3,5x55	–	–	–

- $d_n$  = nominal diameter (e.g. with drywall screw TN 3.5x35, 5x 3.5 mm  $\rightarrow \geq 17.5$  mm penetration depth)
- Always use Diamant Screws when cladding Diamant or Silentboard.

### Maximum fastener spacings – Knauf board cladding

Cladding	1st layer		2nd layer	
	Knauf board width 1200	Knauf board width 600	Knauf board width 1200	Knauf board width 600
1-single-layer	170	150	–	–
2-double-layer <sup>1)</sup>	500	300	170	150

1) Fasten the second board layer within a working day, otherwise the spacing for fastening of single layer cladding must be used.

### Additional screw fastening TU runner

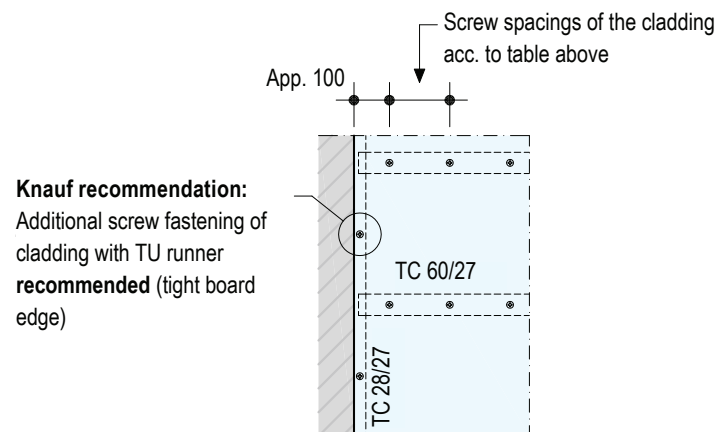

**Caution**

In addition to the application and detail information in this brochure;  
The information in the “TS 1475-3 GYPSUM PLASTERBOARD APPLICATIONS - PART 3: SUSPENDED CEILING APPLICATION RULES” standard must be taken into account.

#### Filling/jointing

Knauf board jointing quality can be between Q1 and Q4 depending on the requested surface quality.

With Fireboard, a skim coating of the entire surface with Knauf Fireboard Spachtel filler is additionally required before application of direct coatings or linings.

#### Suitable jointing materials

- Knauf Uniflott®: It is applied by hand without using joint tape on imported Knauf board joints, and by using joint tape on other Knauf board edges.
- Knauf Fugagips®: It is applied using joint tape on all Knauf board edge types Knauf Fireboard®
- Knauf Fireboard® Joint Filler It is applied by hand in Knauf Fireboard® joints using Knauf Fireboard® joint tape.

#### Suitable finish filling compounds

- Q2, application by hand: Fill & Finish, SuperFinish
- Q3/Q4, application by hand: SuperFinish
- Plastering entire surface of Knauf Fireboard® with Knauf Fireboard® Joint Filler

#### Filling of the gypsum boards

- For multi-layer cladding, fill the lower layers with filler; fill the joints of the visible layer. Filling the joints of covered cladding layers with multi-layer cladding is necessary to ensure technical fire resistance and sound insulation properties as well as the structural properties.
- Fill the visible parts of the fastener.
- Lightly sand visible surfaces after drying of the filler material, if required.

#### Joint filling of the connection joints

- Apply Trenn-Fix and Kurt joint tape when filling joints to adjacent drywall constructions, taking into consideration the conditions and requirements for crack safety.
- Apply Trenn-Fix when filling joints to adjacent solid construction components.

#### Application temperature / climate

- Filling and covering of joints should only take place when no more longitudinal changes can be expected, i.e. expansion or contraction due to humidity or temperature changes.
- Do not apply filling at room or substrate temperatures below approx. +10 °C
- In case of mastic asphalt screed, cementitious screed and selflevelling screed, fill in board joints after screed has been applied.

Quality Level	Jointing Long edges, tapered edge	Jointing Front edge.	Description of working steps
Q1			<ul style="list-style-type: none"> <li>■ Filling the joints with joint filler using joint tape</li> <li>■ Fill the visible parts of the fastener</li> </ul>
Q2			<ul style="list-style-type: none"> <li>■ Quality level 1 (Q1)+</li> <li>■ Finish (fine finish compound) to achieve a smooth transition to the board surface. (e.g. with Knauf Fugagips®, Knauf Uniflott®, Knauf Fill &amp; Finish Light)</li> </ul> <p>No application marks or ridges may remain visible. Sand off the areas concerned if necessary.</p>
Q3			<ul style="list-style-type: none"> <li>■ Quality level 2 (Q2)+</li> <li>■ Wide jointing of the joints as well as clean and accurate removal of the remaining board liner filling the pores (e.g. with KnaufSatengips®, Knauf Jetsatengips®)</li> </ul> <p>If necessary, i.e. physical ridges and grooves are not acceptable and must be sanded.</p>
Q4			<ul style="list-style-type: none"> <li>■ Quality level 2 (Q2)+</li> <li>■ Complete surface covering of skim coat with a layer thickness of at least 1 mm (e.g. with Knauf Superfinish, Knauf Jetsatengips®)</li> </ul>

#### Caution

In addition to the application and detail information in this brochure;

The information in the “TS 1475-3 GYPSUM PLASTERBOARD APPLICATIONS - PART 3: SUSPENDED CEILING APPLICATION RULES” standard must be taken into account.

### Coatings and linings

For direct application of a coarse texture wallpaper, the surface must at least have quality level Q2.

For direct application of a textured paint coat, the surface must at least have quality level Q3.

With Fireboard, the surface must be completely filled in both cases, e.g. with Knauf Fireboard filler.

#### Pretreatment

Before applying coatings such as paint and wallpaper, the Knauf board surface should be cleaned from dust.

If necessary, it should be primed. The properties of the primer should be selected in accordance with the coating to be applied.

Primers such as Knauf Tiefengrund / Putzgrund can be used to balance two different absorption surfaces, such as joint filler and cardboard.

#### Suitable coatings and linings

The following coatings/linings can be applied to Knauf boards;

- Plaster and filler material;
  - Finishing plasters: (Knauf Satengips®, Knauf Jetsatengips® etc.)
  - or surface sealant (Knauf Superfinish etc.)Finishing plasters should be applied after the joint tape and joint filling process are finished.
- Paints:
  - Dispersion paint
  - Multicoloured (rainbow) emulsion
  - Silicate-based emulsion paints with suitable primer.

After wallpapering or after application of plasters, quick drying must be ensured through adequate airing.

#### Unsuitable coatings and linings

- Alkaline coats such as lime, water glass paints and silicate-based paints.

#### Note

Gypsum board surfaces that have constantly been exposed to light without any protection can cause yellowing after coating. The yellowing agents are soluble in water and can penetrate through to the next coating layers and impair the adhesion properties of filler materials. In this case, the application of special primers are recommended.

Other coatings or layers and vapour barriers up to about 0.5 mm thickness as well as claddings (with the exception of sheet steel), do not have any influence on the technical fire resistance classification of Knauf board ceilings.

#### Caution

In addition to the application and detail information in this brochure;

The information in the “TS 1475-3 GYPSUM PLASTERBOARD APPLICATIONS - PART 4: FINISHING WORKS APPLICATION RULES” standard must be taken into account.

### Delivery, Storage and Transport

- Boards and other materials must be received in the form of pallets, containers or ties in their original unopened packages bearing the name of the manufacturer or supplier.
- The materials must be stored in a dry environment, at a room temperature of 5°C and above. It should be protected from direct sunlight and any outdoor weather conditions or from wetting, contamination from the surface, heavy field and construction site conditions and other similar damages. It should be stored in closed or semi-enclosed environments.
- Plasterboards must be kept horizontally on pallets, not vertically. Corners, cut edges and surfaces must be protected.

### Material requirement per m<sup>2</sup>- without fire resistance (Board direction is vertical)<sup>1)</sup>

Description	Unit	Amount as average value						
		D112				D116		
		1	2	3	4	5	6	
<b>Connection to wall</b>								
Acoustical sealant (if required)	m	0,4						
Profile TU 28x27x0,6 mm	m	0,4	0,4	0,4	0,4	0,4	0,4	
Suitable anchors	pcs	0,7	0,7	0,7	0,7	0,7	0,7	
<b>Metal Grid</b>								
Suitable anchors	pcs	1,3	1,5	2,1	2,1	0,7	1,8	
Alternative	Universal bracket	pcs	1,3	1,5	2,1	–	–	–
	2x metal screw MB 3,5x11	pcs	2,6	3	4,2	–	–	–
Alternative	Hanging wire + rapid hanger	pcs	1,3	1,5	–	–	–	–
Alternative	Nonius hanger bottom + Nonius hanger top + Nonius splint	pcs	1,3	1,5	2,1	2,5	–	–
	Nonius hanger bottom + Nonius hanger top + Nonius hanger pin (UA 50)	m	1,2	–	–	–	0,7	1,8
TC profile 60/27 (0,6mm)	m	3,3	3,2	3,5	4,3	2,1	2,1	
Longitudinal connector for TC	pcs	0,7	0,6	0,7	0,7	0,4	0,4	
UA Profile 50x50x2 mm	m	–	–	–	–	1,1	1,4	
TC Profile 50x40x0,6 mm (UA extension)	m	–	–	–	–	0,04	0,06	
Wafer head screw	pcs	–	–	–	–	1,8	2,3	
Alternative	Clip (Double)	pcs	2,6	2,3	2,9	4,5	–	–
	2xclip (single)	pcs	5,2	4,6	5,8	9	–	–
Alternative	Universal connector (be imported)	pcs	–	–	–	–	–	–
	Universal connector	pcs	–	–	–	–	–	–
	UA double clip	pcs	–	–	–	–	2,3	2,9
<b>Insulation layer</b>								
Mineral wool e.g. Knauf Insulation	m <sup>2</sup>	Determined acc. to the project						
<b>Knauf boards</b>								
1st layer	m <sup>2</sup>	1	1	1	1	1	1	
2nd layer	m <sup>2</sup>	–	1	1	1	–	1	
<b>Fastening</b>								
1st layer	St	17	9	13	13	17	13	
2nd layer	St	–	17	21	22	–	21	
<b>Jointing</b>								
Joint filler * (e.g. Knauf Fugagips®, Knauf Uniflott®)	kg	0,3	0,5	1	1	0,3	1	
Edge separator (Knauf Trenn-fix) 65 mm wide	m	Determined acc. to the project						
Joint tape * (Net or Kurt paper joint tape)	m	1,2	1,2	1,2	1,2	1,2	1,2	

The amounts refer to a ceiling area of 10 m x 10 m = 100 m<sup>2</sup>

\* With Fireboard cladding: Always use Knauf Fireboard joint filler and tape.

<sup>1)</sup> Boards should be applied vertically. For details, see page. 51. TS 1475-3 should be considered for other applications.

**Note** Material consumption varies according to ceiling area dimensions. It's recommended to be checked specifically for the Project.

### Legend

D112	1
Fire resistane	-
Knauf board	RP
Thickness	12,5 mm
Load class	0,15 kN/m <sup>2</sup>
Axial spacing	1000 mm
Carrying channel CD	900 mm
Furring Channel CD	500 mm

D116	5	6
Fire resistane	-	F90 from below and above
Knauf board	RP	Fireboard®
Thickness	12,5 mm	2x20 mm
Load class	0,15 kN/m <sup>2</sup>	0,50 kN/m <sup>2</sup>
Axial spacing	2050 mm	800 mm
Carrying channel TC	1000 mm	800 mm
Furring Channel TC	500 mm	500 mm

D112	2	3	4
Fire resistane	-	F90 solely from below	
Knauf board	RP	Fireboard®	Flameboard®
Thickness	2x12,5 mm	2x20 mm	2x20 mm
Load class	0,30 kN/m <sup>2</sup>	0,50 kN/m <sup>2</sup>	0,50 kN/m <sup>2</sup>
Axial spacing	750 mm	700 mm	700 mm
Carrying channel CD	1000 mm	800 mm	600 mm
Furring Channel CD	500 mm	500 mm	400 mm

### Example material estimate for carrying and furring channels

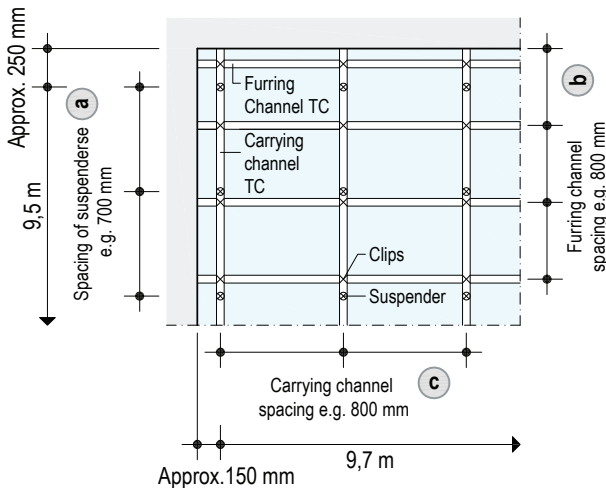

### Carrying TC channel

$$\frac{9,7 \text{ m}}{0,8 \text{ m}} + 1 \text{ pc.} = 13 \text{ pc.}$$

$$\frac{9,7 \text{ m}}{0,8 \text{ m}} + 1 \text{ St} = 14 \text{ pc.}$$

$$14 \text{ (carrying TC channel)} \times 10 \text{ m} = 140 \text{ m}$$

### Furring TC channel

$$\frac{10 \text{ m}}{0,5 \text{ m}} + 1 \text{ pc.} = 21 \text{ pc.}$$

$$\frac{10 \text{ m}}{0,5 \text{ m}} + 1 \text{ pc.} = 21 \text{ pc.}$$

$$21 \text{ (Furring TC channel)} \times 10 \text{ m} = 210 \text{ m}$$

### Suspender

$$\frac{9,5 \text{ m}}{0,7 \text{ m}} + 1 \text{ pc.} = 14 \text{ pc.}$$

$$\frac{9,5 \text{ m}}{0,7 \text{ m}} + 1 \text{ pc.} = 15 \text{ pc.}$$

$$14 \text{ (carrying TC channel)} \times 15 \text{ pc.} = 210 \text{ Adet}$$

### Connector

Carrying channel (pcs.) x furring TC Profile (pc.)

$$14 \text{ (carrying TC channel)} \times 21 \text{ (Furring TC Profile)} = 294 \text{ pc.}$$

## Knauf Document Center

The right systems for your applications

- ▶ The right systems for your requirements range of applications:
- ▶ The appropriate system in just four step;
  - Go to document centre.
  - Select your desired drywalling category.
  - The Knauf system finder shows you a selection of appropriate systems, including downloads and tender specifications.
  - Refine the results with further filter settings.
- ▶ Access the Knauf Document Center [here](#).

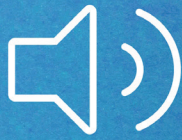

## Knauf Systemfinder

allows you to find most suitable Knauf systems for your project requirements!

- Access up-to-date information and documents, increase productivity, reduce costs, eliminate manual operations, and simplify your daily work processes.
- You can reach Knauf Systemfinder [here](#).

- ▶ 444 YAPI - 9274
- ▶ [www.knauf.com](http://www.knauf.com)
- ▶ [teknik@knauf.com](mailto:teknik@knauf.com)

Center: Knauf Moment Beştepe Ofis, Beştepe Mah. 32.Cadde No:1/212-218 06560 Beştepe-Yenimahalle / ANKARA  
Phone: 0312 297 0100 Fax: 0312 266 4506