



KNAUF



***PERMAROCK®
EXTERIOR
CEILING SYSTEM***

PERMAROCK® Cement Board Outdoor



PERMAROCK®



Build on us.

Knauf PERMAROCK® Exterior Ceiling System is engineered to withstand the most challenging of wet conditions.

All works undertaken to prescribe the use of or to install Knauf's products and systems must be performed by experienced and, where required by applicable laws, appropriately licensed personnel. Knauf's products and systems must be installed in accordance with Knauf's installation manual, Systems+, and any other product or system specific literature issued by Knauf. If installation works are not performed in compliance with such product literature, by experienced and licensed personnel, or are incorrectly performed by experienced or licensed personnel, there is a serious risk that the works, application and performance of the relevant system or products will be compromised, which could result in property damage, injury or death.

All personnel who undertake works to install Knauf's products and systems must comply with all applicable health and safety laws, including wearing appropriate personal protection equipment. If personnel do not comply with applicable health and safety laws, including by not wearing appropriate personal protection equipment, there is a serious risk of injury or death.

All of Knauf's products and systems must only be used for the uses identified in this document (and any other product or system specific literature issued by Knauf from time to time). Before prescribing or using any Knauf product or system for any other use, you must contact Knauf.

All recommended component parts for Knauf's products and systems should be used and not substituted for other products. If component parts are substituted, there is a serious risk that the works, application and performance of the relevant system or products will be compromised, which could result in property damage, injury or death.



System introduction

Knauf PERMAROCK® Exterior Ceiling System is a high-performance, economical and sustainable solution for dry lining style construction of exteriors.

From external soffits, underpasses or open and underground car parks to exterior ceilings, our solution is engineered to withstand the most challenging wet conditions.

Outstanding protection against high humidity and moisture

Knauf PERMAROCK® Exterior Ceiling System is the perfect solution for ceilings exposed to moisture, wind loading and coastal environments. The components are designed and tested to achieve the highest performance of construction. Knauf PERMAROCK® Cement Board Outdoor is water-resistant and made of inorganic materials, which prevents mildew from forming and spreading.

The steel framing system, designed to support PERMAROCK® Cement Board Outdoor is supplied by Rondo, with

components coated with Zinc Z275/Z450, making it suitable for a variety sheltered exterior ceiling applications (refer Rondo for details).

Options for external finishes

Knauf recommends a proprietary render system from specialist companies, such as Sto, Dulux, Euromix and Astec or equivalent.

Simple installation

The combination of lightweight materials and the simplicity of installation make the overhead work easier and faster.

Complete Knauf engineered solution backed by industry experts.

Our team of Engineers and Specification Managers will provide you with support throughout the project; from conceptual design, reviewing Architectural drawings and site support to ensure optimum performance in design and construction.

EXTERNAL SOFFITS AND CEILINGS

Benefits

- › Simple installation
- › Easy to cut, score and snap
- › No pre-drilling for fasteners
- › Resistant to moisture and driving rain
- › Mould and mildew-resistant
- › Dimensionally stable, robust and durable
- › Not deemed combustible (AS 1530.1-1994)
- › Creative design opportunities
 - › Options for the creation of curved ceilings
 - › Spectacular ceilings thanks to expansion joints that are only needed every 15 m and enable a 225 m² closed area without a visible joint*
- › Choice of recommended proprietary render systems
Ideal dry lining solution for exterior ceilings such as soffits, undersides of balconies, underpasses and underground car parks with proven resistance to moisture or mildew forming and spreading.

With Knauf PERMAROCK® Exterior Ceiling Systems, exterior ceilings are optimally protected against various types of weather effects, regardless of their location.

*A control/movement joint must be installed if there is a control/movement joint in the structure above.



Zuidzicht | Hassel, Belgium

Physical properties	
Length (mm)	3,000
Width (mm)	1,200
Thickness (mm)	12.5
Min. bending radius for 1,200 mm wide board (m)	3
Min. bending radius for 300 mm wide strip (m)	1
Weight (kg/m ²)	approx. 16
Dry bulk density (kg/m ³) according to EN 12467	approx. 1,150
Bending strength (MPa) according to EN 12467	≥ 7
Tensile strength perpendicular to the plane of the board (N/mm ²) according to EN 319	0.65
Shearing strength (N) according to EN 520	607
pH-value	12
Thermal conductivity (W/mK) according to EN ISO 10456	0.35
Thermal expansion (10 ⁻⁶ K ⁻¹)	7
Water vapour diffusion coefficient μ (-) according to EN ISO 12572	66
Length variation 65% - 85% humidity (mm/m) according to EN 318	0.23
Thickness variation 65% - 85% humidity (%) according to EN 318	0.2
Building material class according to AS 1530.1-1994	NOT deemed COMBUSTIBLE

EXTERIOR CEILING SYSTEM WITH PERMAROCK® CEMENT BOARD OUTDOOR

THE EXTERIOR CEILING SYSTEM

1. PERMAROCK® Cement Board Outdoor
2. Knauf Maxi Screws
3. 3-5 mm gap in adjacent boards at the long and short edges. Ensure short edges located on top hat section.
4. Proprietary render system. Refer architect and render system supplier, such as Sto, Dulux, Euromix and Astec Paints or equivalent for details
5. Rondo M535 top hat sections
6. Rondo continuous stud rail (Bracing, dropper studs/struts and support framing not shown for clarity. Refer Rondo for design and details)

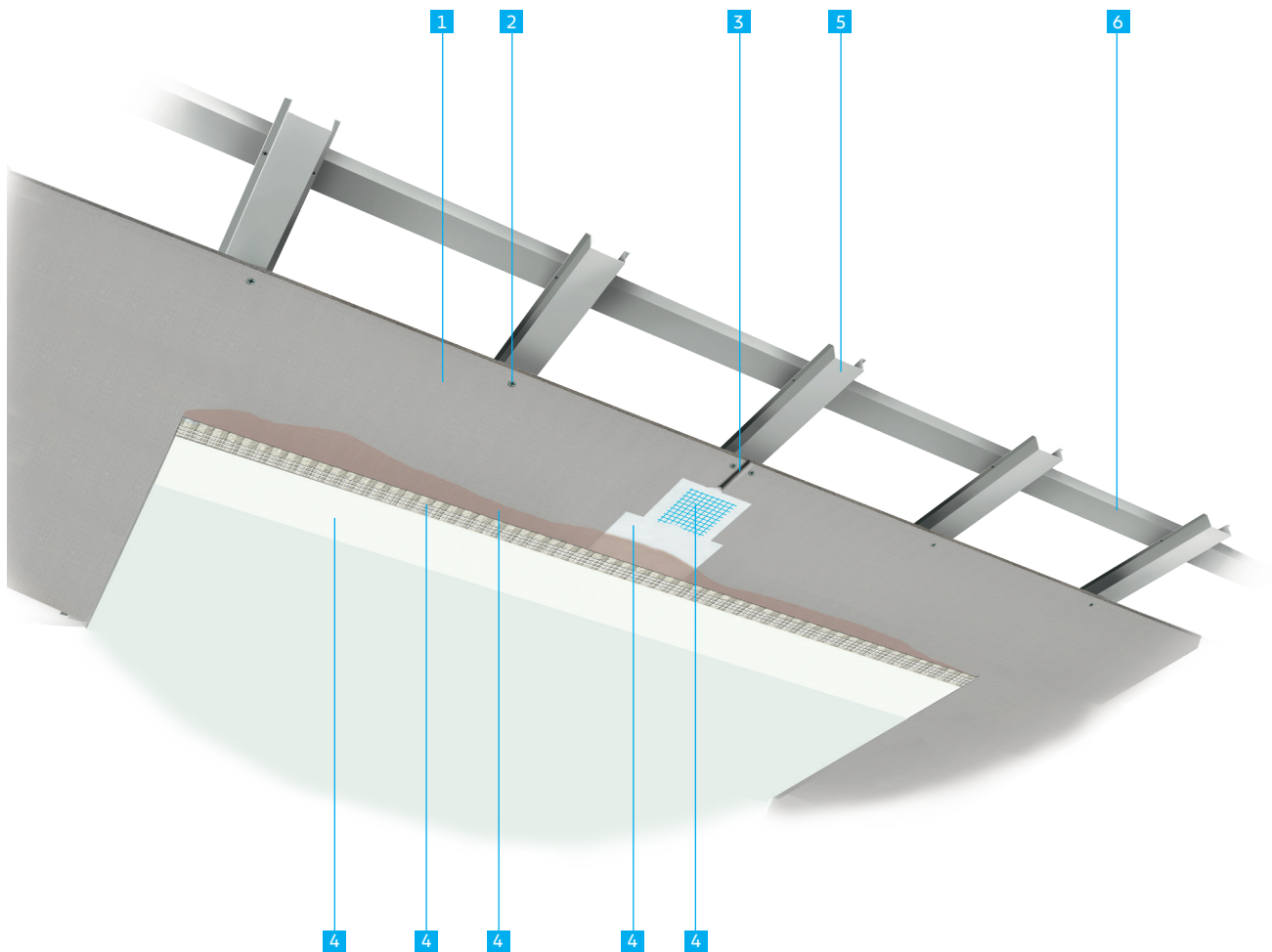

INSTALLATION

Install Rondo M535 top hats at 300 mm centres and framing system to Rondo's design and details. Ensure framing set out accommodates for control joints in PERMAROCK® Cement Board Outdoor and the building structure.

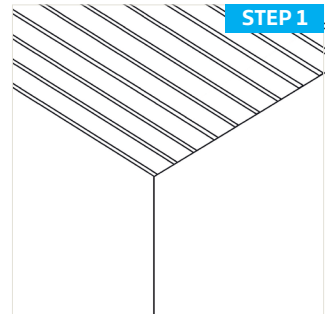

Align the first PERMAROCK® Cement Board Outdoor panel carefully, perpendicular to the Rondo top hat sections. Screw the panel to the framework at minimum 15 mm from the edge with Knauf Maxi Screws. Also ensure screw is no more than 50 mm from corner of panel. Refer to information in this brochure for screw type and spacing details. The distance between the supporting top hats is a maximum of 300 mm maximum centres.

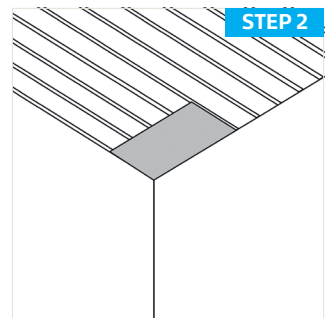

With subsequent board installation, leave 3-5 mm between adjacent boards on all sides. Make sure all short edges are supported by the top hat sections and staggered minimum 600 mm. Cross joints are not permitted. We recommend that control joints are installed in the PERMAROCK® Cement Board Outdoor at 15 m maximum intervals and to coincide with building control joints.

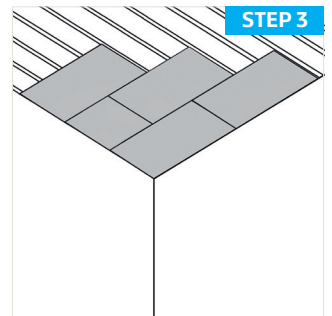

The result is a maximum jointless area of 15 m x 15 m. Special ceiling geometries, e.g. highly angled ceiling surfaces, may, in individual cases, require a narrower arrangement of control joints (refer Knauf for information).

PERMAROCK® exterior ceiling system is ready to accept a proprietary render system. Refer to Architect and render system supplier, such as Sto, Astec Paints or Dulux Acratex for installation details.

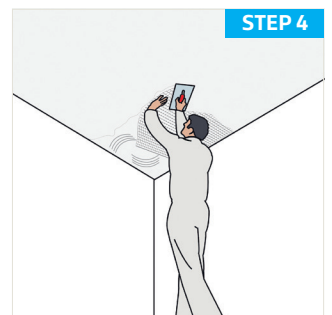

PERMAROCK® Cement Board Outdoor Screw Fixing Table

Ultimate Wind Pressure (kPa)	Permarock Board Span (mm)	Screw Spacing (mm)	Notes:
1	300	250	<ol style="list-style-type: none"> Selfweight of 12.5 mm Permarock Cement Board Outdoor - 16 kg/m². PERMAROCK® Cement Board Outdoor span at 300 mm maximum. PERMAROCK® Cement Board Outdoor span over minimum 3 supports. Contact Knauf for information if otherwise. Ultimate limit state checked for the following cases. <ol style="list-style-type: none"> 1.2G + W_U 0.9G – W_U An allowance of 9.5 kg/m² Dead load for thermal insulation and proprietary render system. Screw fixing tables are not suitable for cyclonic regions. Contact Knauf for information. Refer to Rondo for design and details of support framing system. Seismic loads are not considered in the determining span tables. Refer to Knauf (www.knauf.com) or Rondo (www.Rondo.com.au) for information.
1.25			
1.5			
1.75			
2			
2.25			
2.5			
2.75			
3			
3.25			
3.5			
3.75			
4			
4.25			
4.5			

External Top Hat Rondo M535 Span Table

Ultimate Pressure (kPa)	Service Pressure (kPa)	Top Hat Max Span (mm)			Top Hat spacing (mm)	Notes:
		1- Span	2- Span	3- Span		
1	0.67	1480	1980	1820	300	<ol style="list-style-type: none"> Selfweight of 12.50 mm PERMAROCK® Cement Board Outdoor - 16 kg/m² Top hat at spacing at 300 mm centres. Serviceability checked for the following cases <ol style="list-style-type: none"> L/500 under Dead load only L/360 for Dead + Wind (service) Ultimate limit state checked for the following cases <ol style="list-style-type: none"> 1.2G + W_U 0.9G - W_U All sections have been designed in accordance with AS/NZS 4600:2018 using effective width method. Span tables are not suitable for cyclonic regions. In such case, refer to Rondo for details. Refer to Project Structural Engineer for determining the applicable wind pressures. Seismic loads are not considered in the determining span tables. Refer to Rondo (www.Rondo.com.au) for information.
1.25	0.84	1390	1860	1720		
1.5	1	1320	1770	1630		
1.75	1.17	1260	1700	1560		
2	1.34	1220	1630	1500		
2.25	1.51	1170	1580	1450		
2.5	1.68	1140	1440	1410		
2.75	1.84	1110	1320	1370		
3	2.01	1080	1210	1330		
3.25	2.18	1050	1130	1280		
3.5	2.35	1030	1050	1190		
3.75	2.51	1000	980	1120		
4	2.68	980	930	1050		
4.25	2.85	970	870	990		
4.5	3.02	950	830	940		

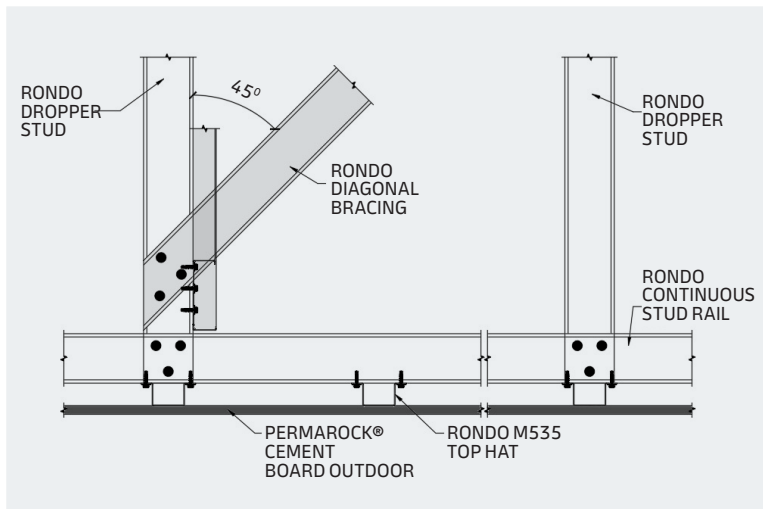

Material of substructure	Steel framework	
Metal thickness (mm)	0.6 ≤ x ≤ 1.0	1.0 < x ≤ 2.0
Number of board layers	Single layer	Single layer
Knauf Maxi Screw SN25	x	
Knauf Maxi Screw SN39	x	
Knauf Maxi Screw SB25		x
Knauf Maxi Screw SB39		x

Notes:

- Minimum distance from the screw to the edge of the board is 15 mm.
- Maximum distance from the corner of the board to the screw is 50 mm.
- Screws should be equally spaced.

EXTERIOR CEILING PROJECTS



iADC Design Museum | Shenzhen, China



Suzhou No.2 Library | Suzhou, China



Design Hotel in Rovinj | Croatia



Mercedes Showroom | Ypres, Belgium



Aviatorilor 8 | Bucharest, Romania

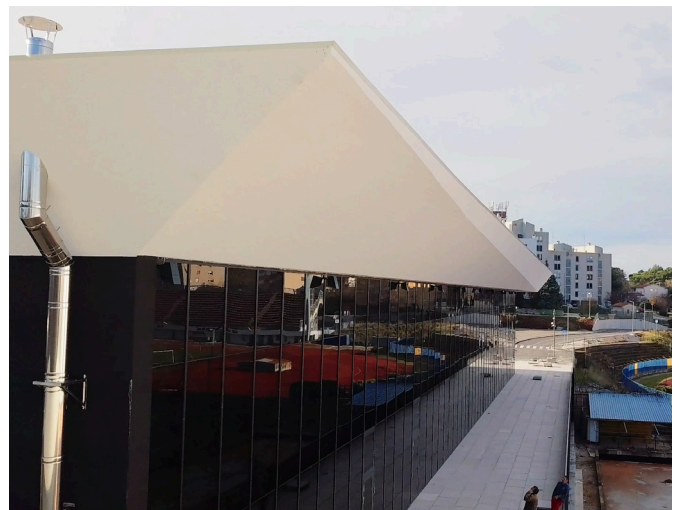

Public Swimming Pool | Pula, Croatia

Knauf Gypsum Pty Ltd.

3 Thackeray Street,
Camellia NSW 2142
Australia

TecASSIST™ +1800 811 222

Sales Enquiries +1800 003 377

www.knauf.com

Technical Resources



CAD Library



eSelector