

# KNAUF

## Drywall Systems

# Knauf KW.111

The Go-To System for Swift Interior Walls.

Boards Data Sheet

2025-09



### System Description

Knauf KW111 Drywall Partition System is a performance-based, non-load-bearing internal partition designed typically for commercial and residential applications. The system consists of a robust metal framework utilizing single Knauf CW Studs and Knauf UW Tracks as head and base channels. The framework is lined on each side with a single layer of Knauf Gypsum Board, secured with Knauf Drywall Screws. The joints are finished with Knauf joint treatment materials, creating a seamless surface ready for decoration.

This system provides an excellent base for a variety of finishes while offering a moderate level of fire resistance and sound insulation performance.

## Build on us.



0-60 minutes



35 - 51dB



3-10m



77-185.8mm



# ***TABLE OF CONTENT***

<b>1. SYSTEM COMPONENTS.....</b>	<b>04</b>
<b>2. INSTALLATION GUIDE.....</b>	<b>09</b>
<b>3. PERFORMANCE SUMMARY.....</b>	<b>10</b>
<b>4. TABLE OF PERFORMANCE.....</b>	<b>12</b>
<b>5. DESIGN CONSIDERATION.....</b>	<b>18</b>
<b>6. TYPICAL CONSTRUCTION DETAILS.....</b>	<b>20</b>

## Gypsum Boards

### ASTM Compliant Boards

---

**Knauf GW-R Gypsum Board**

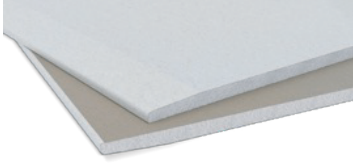

Standard Gypsum Board  
12.7mm & 15.9mm

**Knauf GB-WR Gypsum Board**

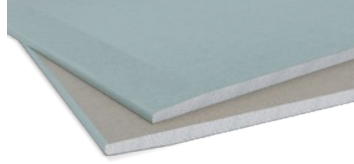

Moisture Resistant Gypsum Board  
12.7mm & 15.9mm

**Knauf GW-TX Gypsum Board<sup>1,2</sup>**

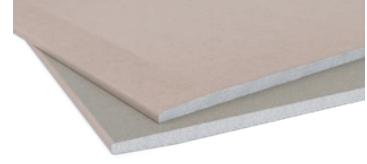

Fire Resistant Gypsum Board  
12.7mm & 15.9mm

### BS EN Compliant Boards

---

**Knauf Regular Gypsum Board**

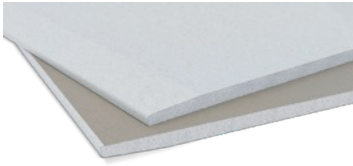

Standard Gypsum Board  
12.5mm & 15mm

**Knauf Moisture Resistant Gypsum Board**

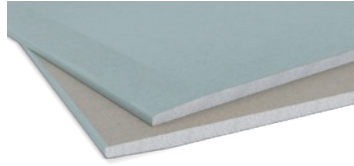

Moisture Resistant Gypsum Board  
12.5mm & 15mm

**Knauf Fire Resistant Gypsum Board<sup>1</sup>**



Fire Resistant Gypsum Board  
12.5mm & 15mm

**Knauf Pro-AcoustiK Gypsum Board**

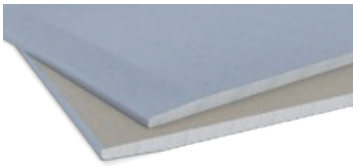

High density fire resistant gypsum board that provides high acoustic performance.  
12.5mm & 15mm

**Knauf Pro-HD Gypsum Board**

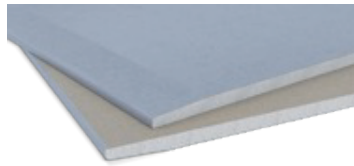

High density fire, moisture, and impact resistant gypsum board.  
12.5mm & 15mm

<sup>1</sup> Moisture resistant version is available & specified in intermittent wet use areas.

<sup>2</sup> Mold resistant version is available & specified in intermittent wet use areas for mold growth prevention.

<sup>3</sup> Impact Variant Available.

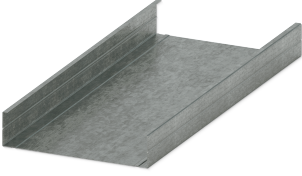
**Metal Profiles****Knauf CW Studs**

Hot-dip galvanized lightweight steel sections that forms the vertical part of Knauf Drywall Partitions framework.

Web: 50, 64, 70, 92, 100, 150mm  
Thickness: 0.5, 0.6, 0.9mm

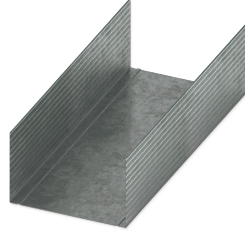
**Knauf UW Tracks**

Hot-dip galvanized lightweight steel sections that serves as a base channel in Knauf Drywall Partitions framework.

Web: 52, 66, 72, 94, 102, 152mm  
Thickness: 0.5, 0.6, 0.9mm

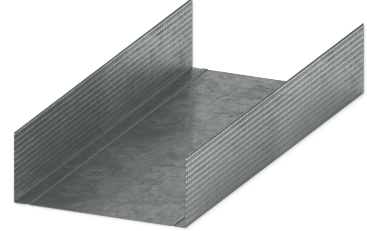
**Knauf UW Tracks**

Hot-dip galvanized lightweight steel sections that serves as a head channel in Knauf Drywall Partitions framework.

Web: 52, 66, 72, 94, 102, 152mm  
Thickness: 0.5, 0.6, 0.9mm

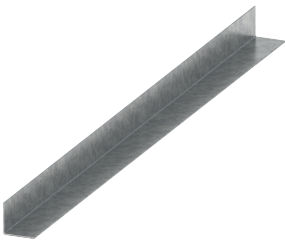
**Knauf L-Angle Section**

Hot-dip galvanized, L-shaped steel profile that can be used to install insulation<sup>1</sup> and for cyclically loaded deflection heads<sup>2</sup>.

<sup>1</sup> 35mm x 25mm

<sup>2</sup> 60mm x 25mm

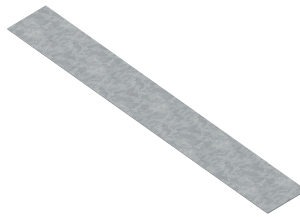
**Knauf Flatfix**

Hot-dip galvanized steel profile that reinforces the horizontal board joints.

Width: 65mm

Thickness: 0.5mm

<sup>1</sup> An angle that can be fixed to the underside of the top track for insulation installation.

<sup>2</sup> An angle that forms a part of Knauf deflection head detail (refer Knauf Typical Details).

## Fixings

### Knauf TN Drywall Screws



Corrosion-resistant, self-tapping screws are designed for securely fastening boards to thin metal sections (up to 0.7mm).

Lengths: 25, 35, 45, 55mm

### Knauf TB Drywall Screws



Corrosion-resistant, self-drilling steel screws are engineered for securely fastening boards to metal sections between 0.8mm and 2mm thick.

Lengths: 25, 35, 45, 55mm

### Knauf LN Screws



Corrosion-resistant, self-drilling steel screws are engineered for securely fastening boards to metal sections between 0.8mm and 2mm thick.

Length: 11mm

### Knauf XTN Screws



Corrosion-resistant, self-drilling steel screws are specifically engineered for securely fastening **Knauf Pro-HD** and **Pro-AcoustiK boards** to metal sections up to 2mm thick.

Lengths: 23 & 38mm

### Knauf Hammer Fixing



Corrosion-resistant screwed-in nails with a nylon plug designed for fixing Knauf Drywall Partitions' perimeter to the structure.

Length: 45mm

### Knauf Wedge Anchor



Corrosion-resistant expansion wedge anchors designed for fixing Knauf Drywall Partitions' perimeter to the structure.

Length: 45mm

### Knauf Concrete Screwbolt



Non-expansion bolt with undercut technology for fixing into wood, brick, cracked or non-cracked concrete for fixing Knauf UW head channel

Length: 100mm

## Corner and Edge Trims

---

### Knauf Metal- Corner Tape



Knauf Metal Corner Tape is a roll of flexible paper tape that includes metal strips. It is used to reinforce both interior and exterior corners. This combination provides added durability and strength to corner joints.

Width: 50mm

### Knauf Perfo Corner Bead

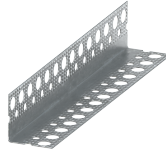

Knauf Perfo Angle Bead offers superior corner finishing and protection for gypsum boards, featuring circular perforated metal wings.

Size: 25 x 25mm

### Knauf Micro Corner Bead

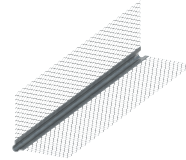

Corner finishing and protection for gypsum boards feature fine expanded metal wings that ensure superior adhesion to plaster, preventing shadowing and reducing the risk of cracking.

Flange width: 32mm

### Knauf Metal- Corner Tape

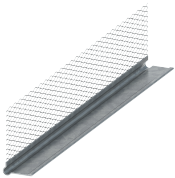

It is an edge finishing bead designed for gypsum boards. It provides protection and prevents damage to the board edges. Additionally, it reinforces the edges for added durability.

Sizes: 32 x 12.5mm & 32 x 15mm

## Insulation

---



Mineral wool based, flexible partition wall insulation roll with minimum dusting and easy application properties improving the system acoustic performance

## Corner and Edge Trims

### Knauf Fill & Finish



Ready-mixed jointing compound for bedding tapes and finishing joints in drywall partitions and ceilings. Delivers up to a Q4 finish.

### Knauf Readygips Joint Filler



Air-drying, asbestos-free, and ready-mixed compound for filling and finishing gypsum board joints and corner beads.

### Knauf EasyFinish



Skimming compound on most interior surfaces such as gypsum boards, sand/cement render & cement fibre boards.

### Knauf Paper Tape

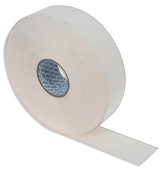

Micro-perforated kraft paper tape that reinforces flat gypsum board joints, offering high crack resistance.

### Knauf Fiber Tape



Self-adhesive fiber tape for flat gypsum board joints reinforcement.

### Knauf Acoustic Sealant



White colored, acrylic based sealant which improves sound insulation and acoustic performance when applied in drywall partitions.

### Knauf FR Sealant



Grey colored, acrylic based sealant which improves sound insulation and acoustical performance when applied in fire-rated drywall partitions.

## Installation Procedure

Knauf Systems are designed to be simple and fast to install. Knauf Technical Services are on hand should you have any questions or unusual situations to deal with.



1. After fixing the head track, the floor track should be positioned by using a vertical stud a laser/ spirit level.



2. Fixing Knauf 'C' Stud to form the partition frame abutment.



3. Twisting Knauf 'C' Stud into position.

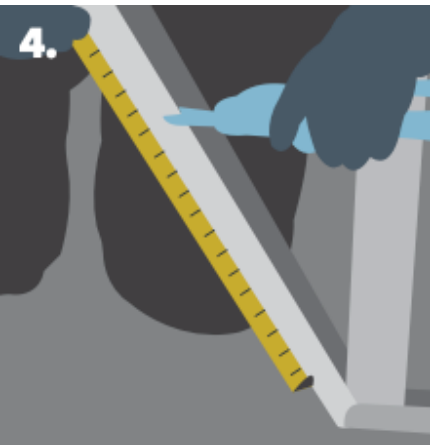

4. Snip and bend back Knauf 'U' Channel for extra rigidity around door openings.



5. Insert timber battens within Knauf 'C' Studs to provide fixing for door frame (if required).

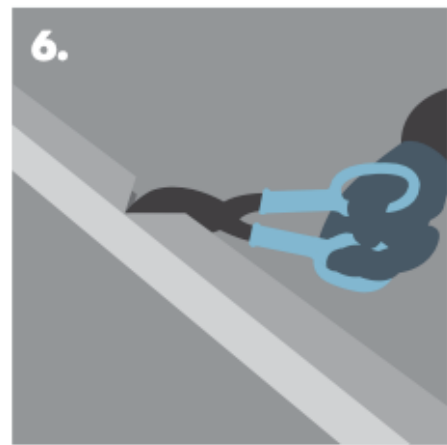

6. Snip and bend back Knauf Deep Flange 'U' Channel to form the door frame.



7. Fixing Knauf Deep Flange 'U' Channel to studs at door opening.



8. Fixing Knauf Plasterboard to the completed framework.

# PERFORMANCE SUMMARY



ASTM

	Boards		12.7mm GW-R		12.7mm GW-TX	
	Fire		0		0	
	Stud Size	Wall Thickness	Height	Acoustic Performance (dB)-Rw	Height	Acoustic Performance (dB)-Rw
A	50	77.4	3.3	42	3.3	44
B	64	91.4	4	44	4	47
C	70	97.4	4	44	4	47
D	92	119.4	4.7	45	4.7	48
E	100	127.4	4.7	45	4.7	48
F	152	179.4	7.4	45	7.4	48

	Boards		15.9mm GW-R		15.9mm GW-TX	
	Fire		0		60	
	Stud Size	Wall Thickness	Height	Acoustic Performance (dB)-Rw	Height	Acoustic Performance (dB)-Rw
A	50	83.8	3.4	44	3.4	46
B	64	97.8	4.14	44	4.14	48
C	70	103.8	4.14	44	4.14	48
D	92	125.8	5.5	45	5.5	48
E	100	133.8	5.5	45	5.5	48
F	152	185.8	7.9	45	7.9	48

# PERFORMANCE SUMMARY



BS EN

	Boards		12.5 mm RG		12.5 mm FR		12.5 mm Pro-AcoustiK		12.5 mm Pro HD	
	Fire		0		0		0		0	
	Stud Size	Wall Thickness	Height	Acoustic Performance (dB)-Rw	Height	Acoustic Performance (dB)-Rw	Height	Acoustic Performance (dB)-Rw	Height	Acoustic Performance (dB)-Rw
A	50	77	3.3	41	3.3	44	3.3	46	3.3	46
B	64	91	4	43	4	46	4	47	4	47
C	70	97	4	43	4	46	4	47	4	47
D	92	119	4.7	44	4.7	49	4.7	50	4.7	50
E	100	127	4.7	44	4.7	49	4.7	50	4.7	50
F	152	179	7.4	44	7.4	49	7.4	50	7.4	50

	Boards		15mm RG		15mm FR		15mm Pro-Acoustik		15mm Pro HD	
	Fire		0		60		60		60	
	Stud Size	Wall Thickness	Height	Acoustic Performance (dB)-Rw	Height	Acoustic Performance (dB)-Rw	Height	Acoustic Performance (dB)-Rw	Height	Acoustic Performance (dB)-Rw
A	50	82	3.4	43	3.4	46	3.4	48	3.4	48
B	64	96	4.14	46	4.14	47	4.14	49	4.14	50
C	70	102	4.14	46	4.14	47	4.14	49	4.14	50
D	92	124	5.5	46	5.5	49	5.5	51	5.5	51
E	100	132	5.5	46	5.5	49	5.5	51	5.5	51
F	152	184	7.9	46	7.9	49	7.9	51	7.9	51

# TABLE OF PERFORMANCE

## ASTM Boards

CW 50mm (0.5mm) Stud at 609mm c/c - L/240@ 240Pa

Board Lining <sup>1,2</sup>	Height (mm)	Fire Resistance Performance (minutes)	Sound Insulation Performance (dB)		Duty Rating	System Thickness (mm)	System Weight (kg/m <sup>2</sup> )
		ASTM E119	STC	Rw			
1 x 12.7 GW-R (Regular)	3300	-	42	41	Medium	77.4	24.9
1 x 15.9 GW-R (Regular)	3400	-	44	43	Medium	83.8	30.9
1 x 12.7 GW-TX (Fire Resistant)	3300	-	44	44	Medium	77.4	26.7
1 x 15.9 GW-TX (Fire Resistant)	3400	60	46	46	Heavy	83.8	31.9

## BS EN Boards

CW 50mm (0.5mm) Stud at 600mm c/c - L/200@ 240Pa

Board Lining <sup>1</sup>	Height	Fire Resistance Performance (minutes)	Sound Insulation Performance (dB)		Duty Rating	System Thickness (mm)	System Weight (kg/m <sup>2</sup> )
		EN 1364-1	STC	Rw			
1 x 12.5 RG	3300	-	42	41	Medium	77	20.5
1 x 15 RG	3400	-	44	43	Medium	82	29.7
1 x 12.5 FR	3300	-	44	44	Medium	77	28.7
1 x 15 FR	3400	60	46	46	Heavy	82	32.2
1 x 12.5 Pro-AcoustiK	3300	-	46	46	Medium	77	30.7
1 x 15 Pro-AcoustiK	3400	60	48	48	Heavy	82	36.3
1 x 12.5 Pro-HD <sup>3</sup>	3300	-	46	46	Severe	77	30.7
1 x 15 Pro-HD <sup>3</sup>	3400	60	48	48	Severe	82	36.3

<sup>1</sup>Moisture Resistant variant of the board achieves similar performance parameters.

<sup>2</sup>Mold Resistant variant of the board achieves similar performance parameters.

<sup>3</sup>Knauf Pro-HD is a moisture and impact resistant variant of Knauf Pro-AcoustiK.

Acoustic Performance above is based on the inclusion of Knauf 50mm Insulation (16 kg/m<sup>3</sup>).

Estimated values that can be substantiated based on previous tests.

# TABLE OF PERFORMANCE

## ASTM Boards

CW 64mm (0.5mm) Stud at 609mm c/c - L/240@ 240Pa

Board Lining <sup>1,2</sup>	Height (mm)	Fire Resistance Performance (minutes)	Sound Insulation Performance (dB)		Duty Rating	System Thickness (mm)	System Weight (kg/m <sup>2</sup> )
		ASTM E119	STC	Rw			
1 x 12.7 GW-R (Regular)	4000	-	44	43	Medium	91.4	25.06
1 x 15.9 GW-R (Regular)	4140	-	46	46	Medium	97.8	31.06
1 x 12.7 GW-TX (Fire Resistant)	4000	-	47	46	Medium	97.4	26.86
1 x 15.9 GW-TX (Fire Resistant)	4140	60	48	47	Heavy	103.8	32.06

## BS EN Boards

CW 64mm (0.5mm) Stud at 600mm c/c - L/200@ 240Pa

Board Lining <sup>1</sup>	Height	Fire Resistance Performance (minutes)	Sound Insulation Performance (dB)		Duty Rating	System Thickness (mm)	System Weight (kg/m <sup>2</sup> )
		EN 1364-1	STC	Rw			
1 x 12.5 RG	4000	-	44	43	Medium	91	20.66
1 x 15 RG	4140	-	46	46	Medium	96	29.86
1 x 12.5 FR	4000	-	47	46	Medium	91	28.86
1 x 15 FR	4140	60	48	47	Heavy	96	32.36
1 x 12.5 Pro-AcoustiK	4000	-	48	47	Heavy	91	30.86
1 x 15 Pro-AcoustiK	4140	60	49	49	Heavy	96	36.46
1 x 12.5 Pro-HD <sup>3</sup>	4000	-	48	47	Severe	91	30.86
1 x 15 Pro-HD <sup>3</sup>	4140	60	50	50	Severe	96	36.46

<sup>1</sup>Moisture Resistant variant of the board achieves similar performance parameters.

<sup>2</sup>Mold Resistant variant of the board achieves similar performance parameters.

<sup>3</sup>Knauf Pro-HD is a moisture and impact resistant variant of Knauf Pro-AcoustiK.

Acoustic Performance above is based on the inclusion of Knauf 50mm Insulation (16 kg/m<sup>3</sup>).

Estimated values that can be substantiated based on previous tests.

# TABLE OF PERFORMANCE

## ASTM Boards

CW 70mm (0.5mm) Stud at 609mm c/c - L/240@ 240Pa

Board Lining <sup>1,2</sup>	Height (mm)	Fire Resistance Performance (minutes)	Sound Insulation Performance (dB)		Duty Rating	System Thickness (mm)	System Weight (kg/m <sup>2</sup> )
		ASTM E119	STC	Rw			
1 x 12.7 GW-R (Regular)	4000	-	44	43	Medium	97.4	25.2
1 x 15.9 GW-R (Regular)	4140	-	46	46	Medium	103.8	31.2
1 x 12.7 GW-TX (Fire Resistant)	4000	-	47	46	Medium	97.4	27
1 x 15.9 GW-TX (Fire Resistant)	4140	60	48	47	Heavy	103.8	32.2

## BS EN Boards

CW 70mm (0.5mm) Stud at 600mm c/c - L/200@ 240Pa

Board Lining <sup>1</sup>	Height	Fire Resistance Performance (minutes)	Sound Insulation Performance (dB)		Duty Rating	System Thickness (mm)	System Weight (kg/m <sup>2</sup> )
		EN 1364-1	STC	Rw			
1 x 12.5 RG	4000	-	44	43	Medium	97	20.8
1 x 15 RG	4140	-	46	46	Medium	102	30
1 x 12.5 FR	4000	-	47	46	Medium	97	29
1 x 15 FR	4140	60	48	47	Heavy	102	32.5
1 x 12.5 Pro-AcoustiK	4000	-	48	47	Heavy	97	31
1 x 15 Pro-AcoustiK	4140	60	49	49	Heavy	102	36.6
1 x 12.5 Pro-HD <sup>3</sup>	4000	-	48	47	Severe	97	31
1 x 15 Pro-HD <sup>3</sup>	4140	60	50	50	Severe	102	36.6

<sup>1</sup>Moisture Resistant variant of the board achieves similar performance parameters.

<sup>2</sup>Mold Resistant variant of the board achieves similar performance parameters.

<sup>3</sup>Knauf Pro-HD is a moisture and impact resistant variant of Knauf Pro-AcoustiK.

Acoustic Performance above is based on the inclusion of Knauf 50mm Insulation (16 kg/m<sup>3</sup>).

Estimated values that can be substantiated based on previous tests.

# TABLE OF PERFORMANCE

## ASTM Boards

CW 70mm (0.5mm) Stud at 609mm c/c - L/240@ 240Pa

Board Lining <sup>1,2</sup>	Height (mm)	Fire Resistance Performance (minutes)	Sound Insulation Performance (dB)		Duty Rating	System Thickness (mm)	System Weight (kg/m <sup>2</sup> )
		ASTM E119	STC	Rw			
1 x 12.7 GW-R (Regular)	4700	-	45	44	Medium	119.4	25.52
1 x 15.9 GW-R (Regular)	5500	-	46	46	Medium	125.8	31.52
1 x 12.7 GW-TX (Fire Resistant)	4700	-	48	49	Medium	119.4	27.32
1 x 15.9 GW-TX (Fire Resistant)	5500	60	48	49	Heavy	125.8	32.52

## BS EN Boards

CW 92mm (0.5mm) Stud at 600mm c/c - L/200@ 240Pa

Board Lining <sup>1</sup>	Height	Fire Resistance Performance (minutes)	Sound Insulation Performance (dB)		Duty Rating	System Thickness (mm)	System Weight (kg/m <sup>2</sup> )
		EN 1364-1	STC	Rw			
1 x 12.5 RG	4700	-	45	44	Medium	119	21.12
1 x 15 RG	5500	-	46	46	Medium	124	30.32
1 x 12.5 FR	4700	-	48	49	Medium	119	29.32
1 x 15 FR	5500	60	48	49	Heavy	124	32.82
1 x 12.5 Pro-AcoustiK	4700	-	49	50	Heavy	119	31.32
1 x 15 Pro-AcoustiK	5500	60	51	51	Heavy	124	36.92
1 x 12.5 Pro-HD <sup>3</sup>	4700	-	49	50	Severe	119	31.32
1 x 15 Pro-HD <sup>3</sup>	5500	60	51	51	Severe	124	36.92

<sup>1</sup>Moisture Resistant variant of the board achieves similar performance parameters.

<sup>2</sup>Mold Resistant variant of the board achieves similar performance parameters.

<sup>3</sup>Knauf Pro-HD is a moisture and impact resistant variant of Knauf Pro-AcoustiK.

Acoustic Performance above is based on the inclusion of Knauf 50mm Insulation (16 kg/m<sup>3</sup>).

Estimated values that can be substantiated based on previous tests.

# TABLE OF PERFORMANCE

## ASTM Boards

CW 100mm (0.5mm) Stud at 609mm c/c - L/240@ 240Pa

Board Lining <sup>1,2</sup>	Height (mm)	Fire Resistance Performance (minutes)	Sound Insulation Performance (dB)		Duty Rating	System Thickness (mm)	System Weight (kg/m <sup>2</sup> )
		ASTM E119	STC	Rw			
1 x 12.7 GW-R (Regular)	4700	-	45	44	Medium	127.4	25.63
1 x 15.9 GW-R (Regular)	5500	-	46	46	Medium	133.8	31.63
1 x 12.7 GW-TX (Fire Resistant)	4700	-	48	49	Medium	127.4	25.63
1 x 15.9 GW-TX (Fire Resistant)	5500	60	48	49	Heavy	133.8	31.63

## BS EN Boards

CW 92mm (0.5mm) Stud at 600mm c/c - L/200@ 240Pa

Board Lining <sup>1</sup>	Height	Fire Resistance Performance (minutes)	Sound Insulation Performance (dB)		Duty Rating	System Thickness (mm)	System Weight (kg/m <sup>2</sup> )
		EN 1364-1	STC	Rw			
1 x 12.5 RG	4700	-	45	44	Medium	127	21.23
1 x 15 RG	5500	-	46	46	Medium	132	30.43
1 x 12.5 FR	4700	-	48	49	Medium	127	29.43
1 x 15 FR	5500	60	48	49	Heavy	132	32.93
1 x 12.5 Pro-AcoustiK	4700	-	49	50	Heavy	127	31.43
1 x 15 Pro-AcoustiK	5500	60	51	51	Heavy	132	37.03
1 x 12.5 Pro-HD <sup>3</sup>	4700	-	49	50	Severe	127	31.43
1 x 15 Pro-HD <sup>3</sup>	5500	60	51	51	Severe	132	37.03

<sup>1</sup>Moisture Resistant variant of the board achieves similar performance parameters.

<sup>2</sup>Mold Resistant variant of the board achieves similar performance parameters.

<sup>3</sup>Knauf Pro-HD is a moisture and impact resistant variant of Knauf Pro-AcoustiK.

Acoustic Performance above is based on the inclusion of Knauf 50mm Insulation (16 kg/m<sup>3</sup>).

Estimated values that can be substantiated based on previous tests.

# TABLE OF PERFORMANCE

## ASTM Boards

CW 152mm (0.5mm) Stud at 609mm c/c - L/240@ 240Pa

Board Lining <sup>1,2</sup>	Height (mm)	Fire Resistance Performance (minutes)	Sound Insulation Performance (dB)		Duty Rating	System Thickness (mm)	System Weight (kg/m <sup>2</sup> )
		ASTM E119	STC	Rw			
1 x 12.7 GW-R (Regular)	7400	-	45	44	Medium	179.4	26.31
1 x 15.9 GW-R (Regular)	7900	-	46	46	Medium	185.8	32.31
1 x 12.7 GW-TX (Fire Resistant)	7400	-	48	49	Medium	179.4	28.11
1 x 15.9 GW-TX (Fire Resistant)	7900	60	48	49	Heavy	185.8	33.31

## BS EN Boards

CW 152mm (0.5mm) Stud at 600mm c/c - L/200@ 240Pa

Board Lining <sup>1</sup>	Height	Fire Resistance Performance (minutes)	Sound Insulation Performance (dB)		Duty Rating	System Thickness (mm)	System Weight (kg/m <sup>2</sup> )
		EN 1364-1	STC	Rw			
1 x 12.5 RG	7400	-	45	44	Medium	179	21.91
1 x 15 RG	7900	-	46	46	Medium	184	31.11
1 x 12.5 FR	7400	-	48	49	Medium	179	30.11
1 x 15 FR	7900	60	48	49	Heavy	184	33.61
1 x 12.5 Pro-AcoustiK	7400	-	49	50	Heavy	179	32.11
1 x 15 Pro-AcoustiK	7900	60	51	51	Heavy	184	37.71
1 x 12.5 Pro-HD <sup>3</sup>	7400	-	49	50	Severe	179	32.11
1 x 15 Pro-HD <sup>3</sup>	7900	60	51	51	Severe	184	37.71

<sup>1</sup>Moisture Resistant variant of the board achieves similar performance parameters.

<sup>2</sup>Mold Resistant variant of the board achieves similar performance parameters.

<sup>3</sup>Knauf Pro-HD is a moisture and impact resistant variant of Knauf Pro-AcoustiK.

Acoustic Performance above is based on the inclusion of Knauf 50mm Insulation (16 kg/m<sup>3</sup>).

Estimated values that can be substantiated based on previous tests.

**• Positioning Knauf UW Tracks and Knauf CW Studs**

- Mark location of partitions accurately on concrete structure with stringline / laser
- Use Knauf Sealing Tape or Acoustical Sealant under Knauf CW studs and UW Tracks forming the perimeter for acoustic rated partitions.

**• Installing Floor and Ceiling Channels**

Securely fix Knauf Floor & Ceiling Channels to the floor and ceiling by fixing a single row of Knauf anchors at a maximum spacing of 600mm. If the floor is uneven, use a suitably sized timber sole plate, which should be the same width as the channel, to create a level base.

If you're working with a new, damp concrete or screeded floor, it's wise to install a damp-proof membrane between the floor and the channel or sole plate to prevent moisture issues.

**• Framing and Openings****a. Splicing and Stud Extension**

To extend studs, overlap them by a minimum of (stud web x 10) and secure them together using Knauf LN Screws.

**b. Door and Opening Frames**

When planning for doors, you must consider the partition's thickness and how it relates to the door frame. Refer Knauf Door Assembly Details. Always consult with the door manufacturer for specific door details. For high acoustic requirements, seek advice from both door manufacturers and acoustic consultants.

You also need to pre-plan and frame any openings required for services such as horizontal ducts, fire dampers, or access panels. These framed openings should be built using standard metal stud procedures, as per Knauf recommended details.

**c. Control Joints**

Control joints may be necessary to relieve stresses from structural expansion and contraction. They should be applied at:

- Maximum 9m of continuous partition length.
- At all control/expansion joints present in the structure.
- At any change in the substrate material.

**d. Deflection Heads**

Partition head deflection designs are sometimes required to accommodate the vertical movements of the the supporting floor or roof structures, especially those exposed to positive and negative deflection. Refer Knauf deflection head details.

**e. Penetrations**

When services penetrate a fire-resistant or sound-insulating wall, you must take care to ensure the wall's performance isn't compromised. The services themselves must also not act as a conduit for fire or sound. Refer "Service installations" section for more details.

**Electrical Work**

All electrical services should be installed according to BS 7671 or an equivalent international standard. You can use the pre-cut service holes in the studs to route small services and cables. If you need to cut a stud, cut them all from the same end to ensure the cut-outs are aligned. Cables passing through the metal frame must be protected by conduit or other means to prevent abrasion.

For switch and socket boxes, refer Knauf details. For enhanced acoustic performance, you can use a high-performance socket box detail.

**Independent Support for Heavy Services**

For services like fire dampers and their associated ductwork, you must consider their size and weight. If they're too heavy for the partition to support directly, they must be independently supported from the main structure.

**• Fixtures and Fittings**

**a. Lightweight fixtures:** can be attached directly to the plasterboard.

**b. Medium-weight fixtures:** Refer Knauf details.

**c. Heavyweight fixtures,** such as sinks or wall cabinets (meeting BS 5234: Part 2), should be fixed to plywood that is secured as per Knauf details.

**d. Board finishing**

Refer to Knauf installation guidelines.

**e. Tiling**

Tiles up to 32 kg/m<sup>2</sup>. can be applied to the surface of Knauf drywall systems. Tiles up to 70kg/m<sup>2</sup>. can be applied when using Knauf Aquapanel Cement Board Indoor.

Refer to Knauf Tiling Guide for further information.

**f. Mold & moisture protection**

Where additional protection against moisture is required, for example in a bathroom, kitchen or other area subject to intermittent humidity, then the moisture resistant variant of the required board type should be specified. If protection against mold spores forming is required, then Knauf GB-WRTX Gypsum Board MOLD or Knauf Aquapanel Cement Board Indoor should be specified.

## Door Opening

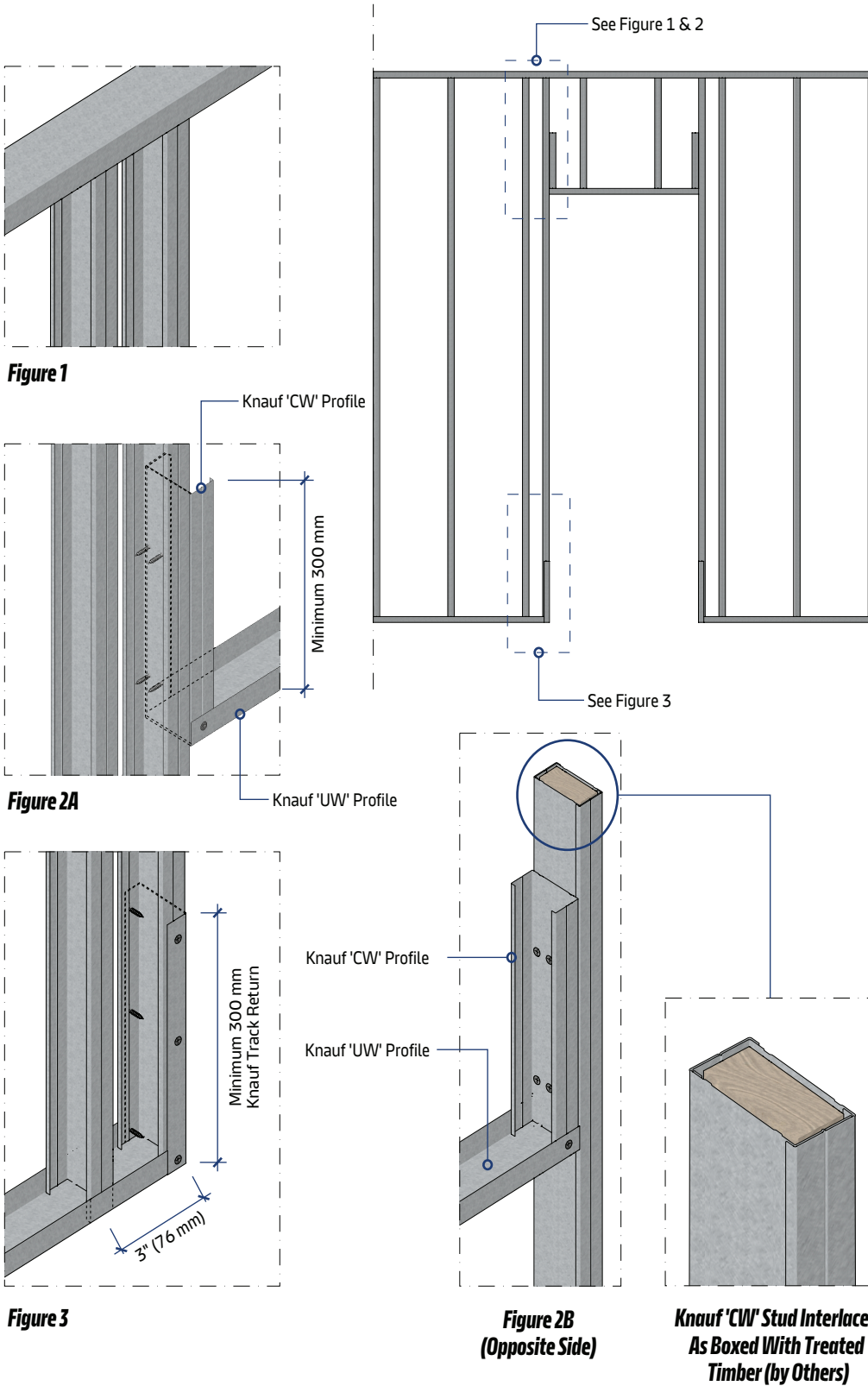

## Service Cutouts

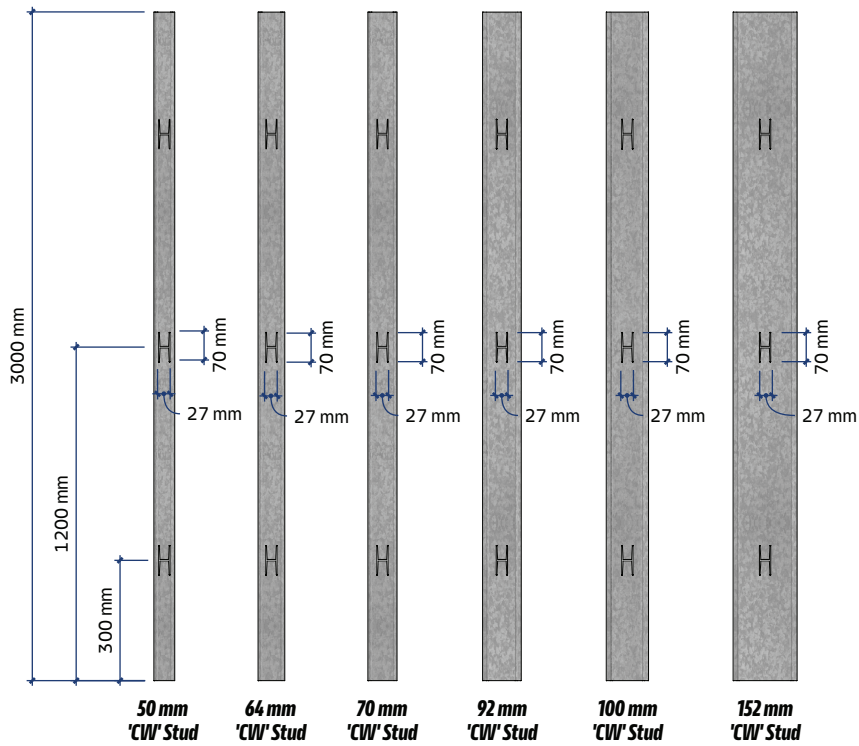

## Stud Splicing

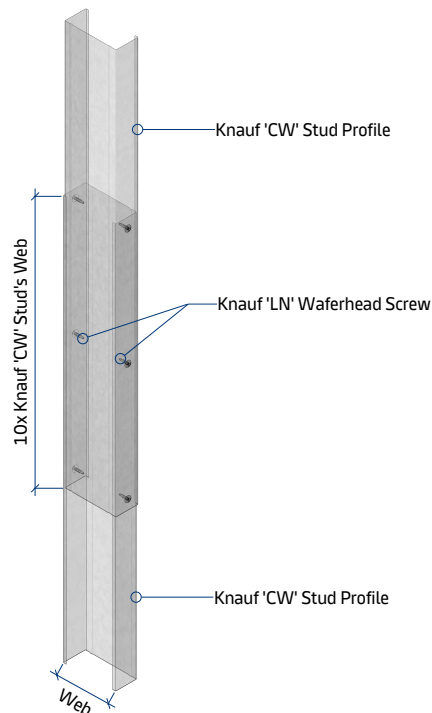

## A System Plan

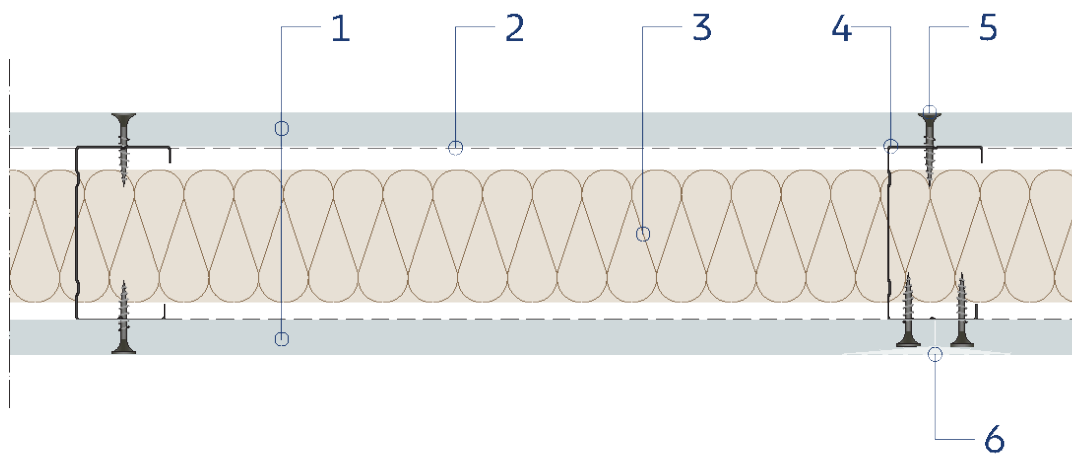

- |                             |                                       |
|-----------------------------|---------------------------------------|
| 1. Gypsum Board             | 4. 'CW' Stud Profile                  |
| 2. 'UW' Track Profile       | 5. 'TN'/'TB' Screw                    |
| 3. Insulation (If Required) | 6. Fill & Finish and Knauf Joint Tape |

**B Deflection Head Detail 10mm**

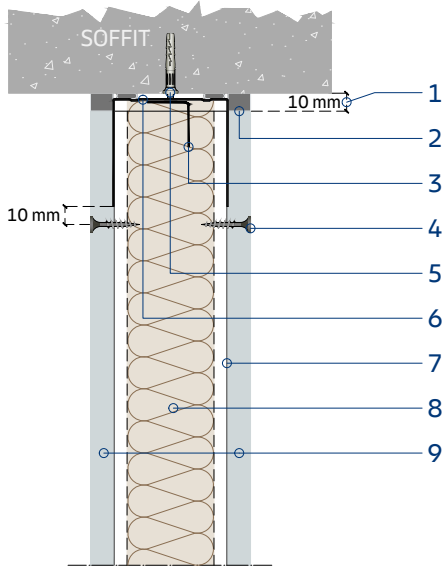

**C Deflection Head Detail 25mm (Option 1)**

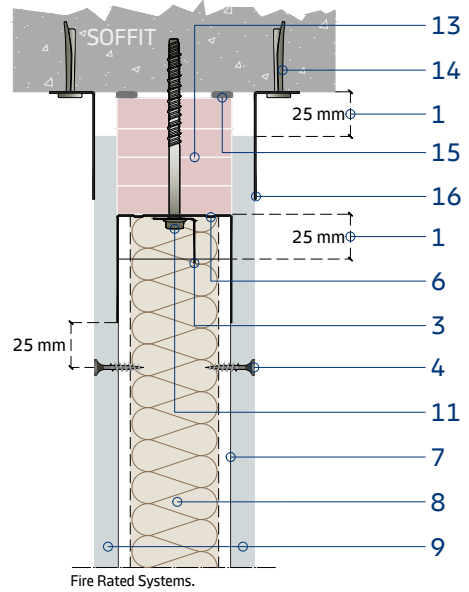

**D Deflection Head Detail 25mm (Option 2)**

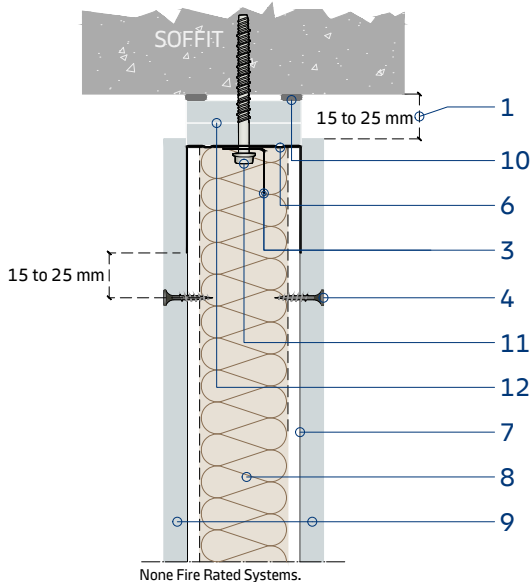

**E Corner Detail**

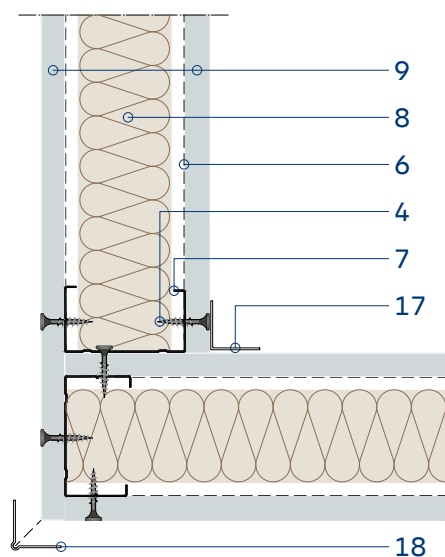

- |                         |                             |   |                 |
|-------------------------|-----------------------------|---|-----------------|
| 1. Deflection Allowance | 6. 'UW' Deep Flange         | 11. Concrete Screwbolt                                  | 16. Knauf Angle |
| 2. Approved Sealant     | 7. 'CW' Stud Profile        | 12. Gypsum Board (2x Strips Cut On Site)                | 17. Paper Tape  |
| 3. L-Angle              | 8. Insulation (If Required) | 13. GW-TX (15.9mm) Gypsum Board (4x Strips Cut On Site) | 18. Corner Bead |
| 4. 'TN'/'TB' Screw      | 9. Gypsum Board             | 14. Wedge Anchor  |                 |
| 5. Approved Fixing      | 10. Acoustic Sealant        | 15. FR Sealant  |                 |

**F** Horizontal Board Joint (Flatfix)

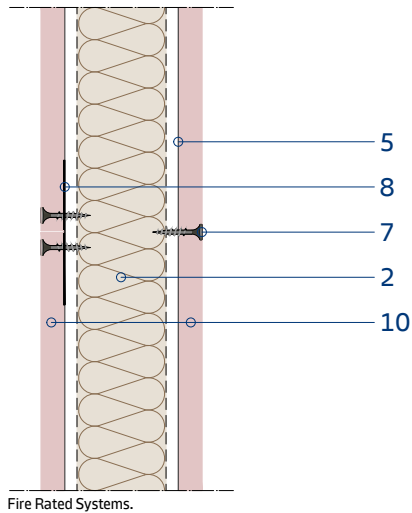

Fire Rated Systems.

**G** Horizontal Board Joint

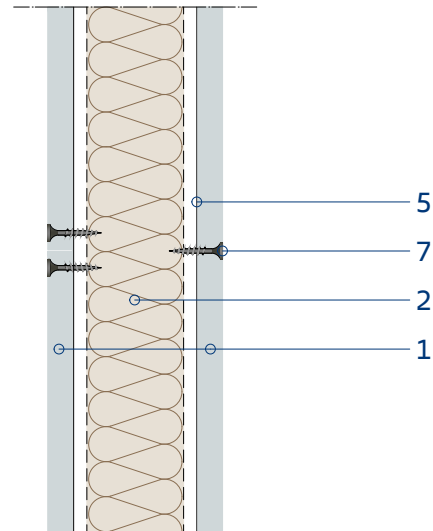

None Fire Rated Systems.

**H** Splayed Angle Detail

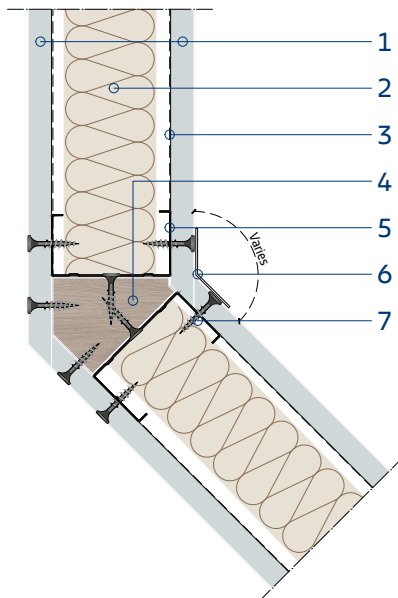

**I** Movement Joint Detail

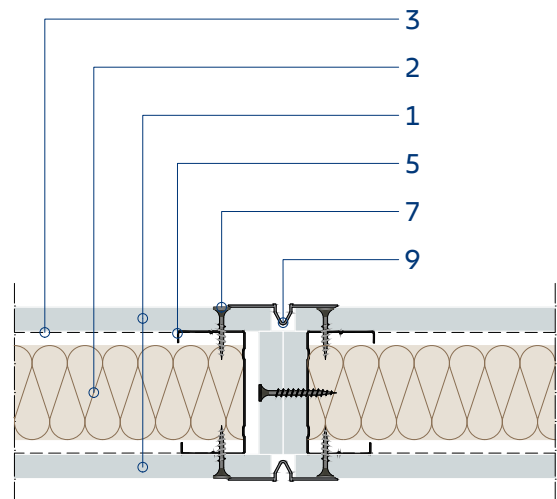

Fire Rated Systems Up To 1 Hour.

- 1. Gypsum Board
- 2. Insulation (If Required)
- 3. 'UW' Track Profile

- 4. Shape Wooden Filler (By Others)
- 5. 'CW' Stud Profile
- 6. Paper Tape

- 7. 'TN'/'TB' Screw
- 8. Flatfix
- 9. PVC Movement Bead

- 10. Fire Rated Gypsum Board

**J** T-Junction Detail 1

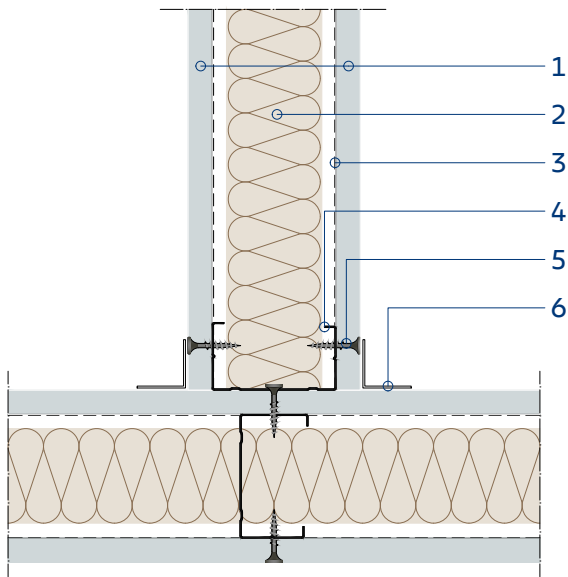

**K** T-Junction Detail 2

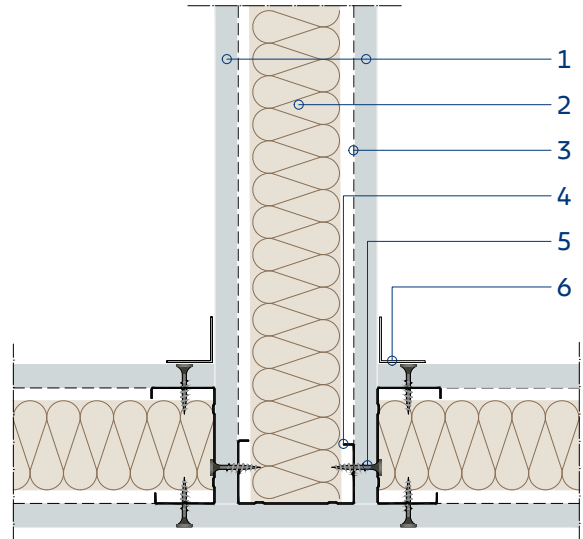

**L** Stop End Detail

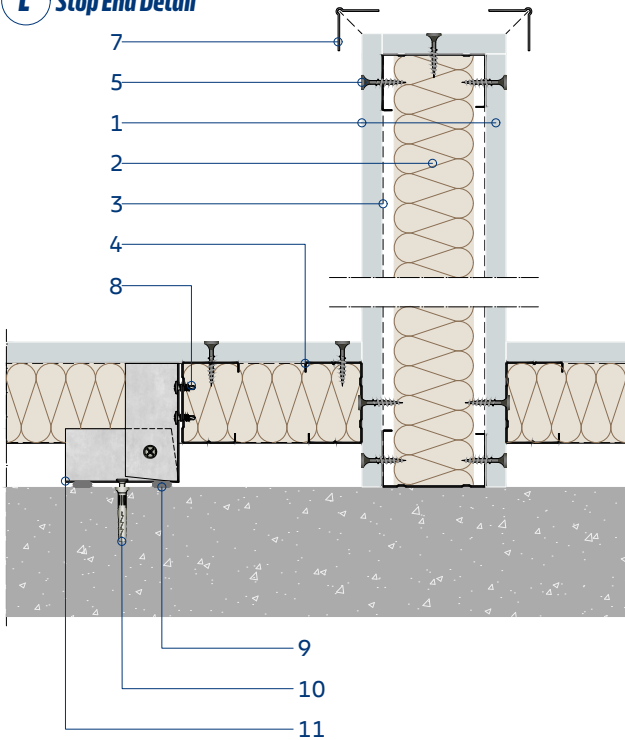

- 1. Gypsum Board
- 2. Insulation (If Required)
- 3. 'UW' Track Profile

- 4. 'CW' Stud Profile
- 5. 'TN'/'TB' Screw
- 6. Paper Tape

- 7. Corner Bead
- 8. 'LN' Waferhead Screw
- 9. Approved Sealant

- 10. Approved Fixing
- 11. 'UW' Runner (Cut Piece)

## Customer Service

UAE Tel: +971 4 33771700  
8:00 - 17:30 (UAE Time)  
Email: GCCcustomer.care@knauf.com  
Email: GCCtechnical.care@knauf.com

## HQ Address

Knauf LLC  
Units B9 & B10 - LIU 6  
Dubai Silicon Oasis  
Dubai, UAE.

## Plant Address

P.O.Box 50006  
Ras Al Khaimah, U.A.E.  
Tel: +971 7 268 9837  
Fax: +971 7 221 5301

## Plant Address

Plot no - RY-PH02-M3-008  
Raysut - WGS-84-Zone 39  
Salalah Free Zone  
Salalah, Dhofar, Oman



**Observe safety data sheet!**  
For safety data sheets and CE labelling see  
[www.Knauf.com](http://www.Knauf.com)



**Tender texts for all Knauf systems and products with export functions for Word and PDF.**



**Videos for Knauf systems and products can be found under the following link:**  
[youtube.com/knauf](https://youtube.com/knauf)



**All information and documents from Knauf GCC are now always up-to-date,**

## Knauf GCC

Dubai, United arab Emirates

*Subject to technical changes. The current edition applies. The information contained herein corresponds to our current state of the art. The generally recognised rules of construction technology, relevant standards, guidelines and trade regulations must be observed by the contractor in addition to the processing instructions. Our warranty relates only to the flawless quality of our material. Consumption, quantity and execution data are empirical values that cannot be transferred without further ado in the event of deviating conditions. All rights reserved. Changes, reprinting and photomechanical and electronic reproduction, even in extracts, require our express authorisation.*

## Hotline

800 - KNAUF(56283)

**The structural, static and physical properties of Knauf systems can only be guaranteed if only Knauf system components or products recommended by Knauf are used.**

[www.knauf.com](http://www.knauf.com)

