

ACCESS PANEL TECHNICAL DATA SHEET

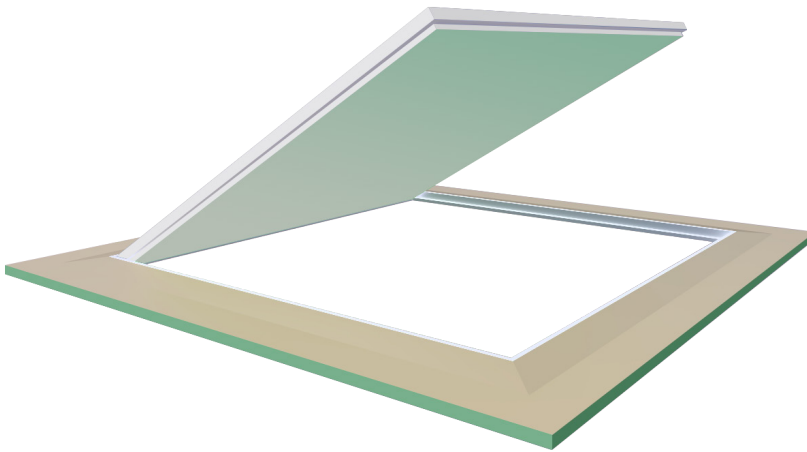

Knauf Access Panel is a gypsum board access panel design to suit the Knauf concealed ceiling system. Knauf Access Panel allows for easy above the ceiling maintenance work. It uses aluminum trimmings around its perimeter access to ensure long term durability from wear and tear.

Product Features

- Designed with a frameless feature, make it look like there is nothing on the ceiling.
- Various shapes are also available to match with the design, including Square corners and Rounded Corners
- Available in 2 types to fit with the usage, Standard type for general uses i.e. Dining room, Parlor, or Hallway and Moisture Resistant type (MoistureShield) for the area that contact with high humidity i.e. Bathroom or Kitchen.

Product Information

Type	Panel Size (Width x Length)	Frame Size (Width x Length)
Access Panel MoistureShield	300mm x 300mm	500mm x 500mm
	450mm x 450mm	650mm x 650mm
	600mm x 600mm	800mm x 800mm

*Available to fit with 12mm gypsum board ceilings

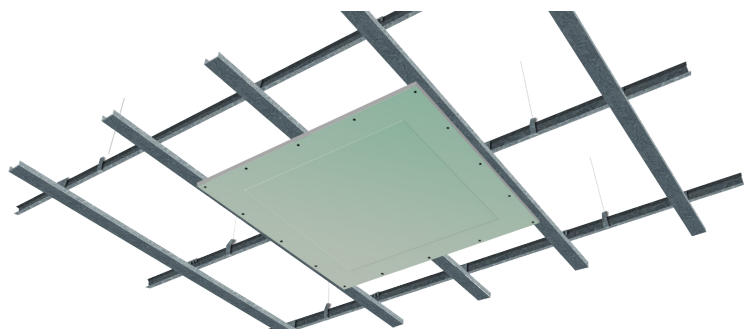

Recommended Access Panel Ceiling
Frames (300mm x 300mm)

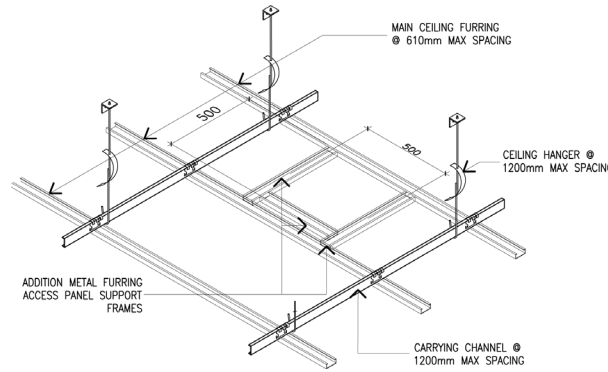
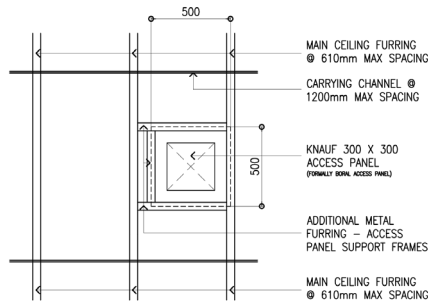

Recommended Access Panel Ceiling
Frames (600mm x 600mm)

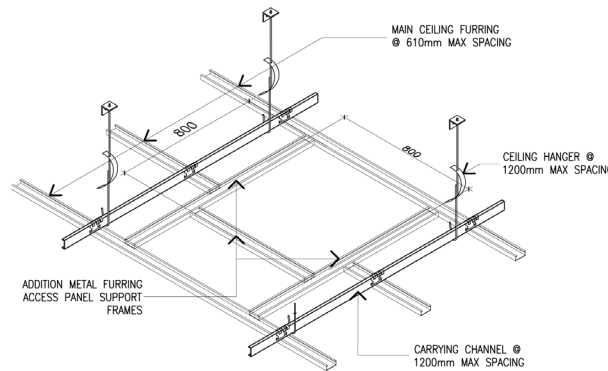
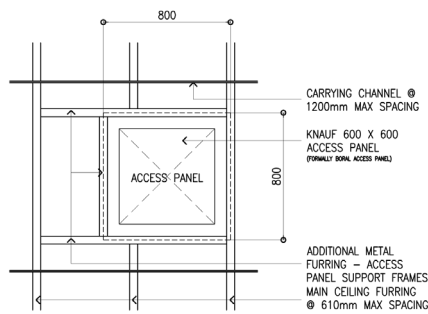

For latest updates and other information, scan code to visit Knauf Gypsum Philippines official website or social media pages.



Submittal Approval : _____

Job Name Contractor : _____

Date : _____

: _____

: _____

Knauf Gypsum Philippines, Inc.

www.knaufapac.com/en_ph
info.ph@knauf.com

(+63) 2 8911 6709
63 917 853 3593

Pasig City Office:

14th Floor – Office 2, One Paseo Building,
Paseo de Arco corner E. Rodriguez Jr.
Avenue (C5), ArcoVia City, Pasig City

1604 Philippines

Plant:

Km. 117 National Highway, Calaca
Industrial Seaport Corp., Brgy. Lumbang
Calzada, Calaca, Batangas

4212 Philippines

Knauf Academy:

Lot 35 Block 11, E. Rodriguez Jr.
Avenue, Bagumbayan Quezon City

1008 Philippines