

Note on English translation / Hinweise zur englischen Fassung

This is a translation of the System Data Sheet valid in Germany.

All stated details and properties are in compliance with the regulations of the German standards and building regulations. They are only applicable for the specified products, system components, application rules, and construction details in connection with the specifications of the respective certificates and approvals.

Knauf Gips KG denies any liability for applications outside of Germany as this requires changes acc. to the respective national standards and building regulations.

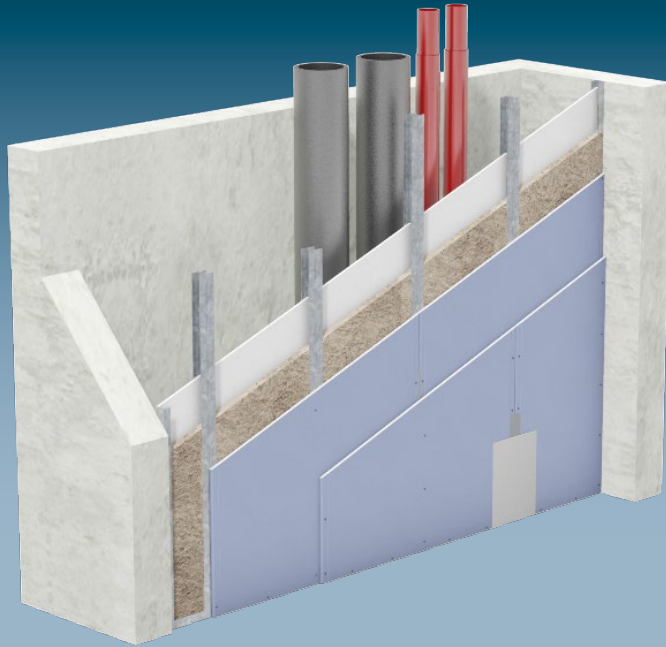

Drywall Systems

W62.de

System Data Sheet

2018-03

Knauf Installation Shaft Walls

W628A.de – Installation Shaft Wall – Free spanning

W630.de – Installation Shaft Wall – Stud crossbars with CW profiles

W628B.de – Installation Shaft Wall – Stud construction with CW profiles

W629.de – Installation Shaft Wall – Stud construction with CW double profiles

K251.de – Fireboard Installation Shaft Wall – Stud construction with CW double profiles

W635.de – Installation Shaft Wall – Stud construction with UW double profiles

NEW

- New installation shaft wall heights
- Deflection head
- Equivalent connection to columns and beams
- Installation shaft wall upgrade

Contents

Usage Instructions	
Notes	4
Notes on the document.....	4
References to other documents.....	4
Intended use of Knauf systems.....	4
General instructions.....	4
Installation zones acc. to DIN 4103-1.....	4
Notes on sound insulation.....	4
Certificate of usability	5
Introduction	
System overview	6
Data for planning	
W628A.de Installation Shaft Wall – Free-spanning	8
System variants.....	8
Wall heights.....	9
W630.de Installation Shaft Wall stud crossbars with CW profiles	10
System variants.....	10
Wall heights.....	11
W628B.de Installation Shaft Wall with single stud profile	12
System variants.....	12
Wall heights.....	13
W629.de Installation Shaft Wall with double stud profiles	14
System variants.....	14
Wall heights.....	15
K251.de Fireboard Installation Shaft Wall with double stud profiles	16
System variants.....	16
Wall heights.....	17
W635.de Installation Shaft Wall with double stud profiles	18
System variants.....	18
Wall heights.....	19
Construction details	
W628A.de Installation Shaft Wall – Free-spanning	20
W630.de Installation Shaft Wall stud crossbars with CW profiles	22
W628B.de Installation Shaft Wall with single stud profiles	24
W629.de Installation Shaft Wall with double stud profiles	26
K251.de Fireboard Installation Shaft Wall with double stud profiles	28
W635.de Installation Shaft Wall with double stud profiles	30
Special details	32
Special versions	
Upgrading of installation shaft walls	37
Cable lead-throughs	38

	Installation and application	
	Stud frame	40
	Stud frame Insulation layer	41
	Cladding	42
	Jointing	44
	Coatings and linings	45
	Material requirement	
	Knauf Installation Shaft Walls	46
	Information on the sustainability	
	Knauf Installation Shaft Walls	48

Notes on the document

Knauf System data sheets are the planning and application basis for the planners and professional installers with the application of Knauf systems. The contained information and specifications, constructions, details and stated products are based, unless otherwise stated, on the certificates of usability (e.g. National Technical Test Certificate (abP) and/or German National Technical Approvals (abZ)) valid at the date they are published as well as on the applicable standards. In addition, design and structural requirements and those regarding building physics (fire protection and sound insulation) are considered.

The contained construction details are examples and can be used in a similar way for various cladding variants of the respective system. At the same time, the demands made on fire resistance and/or sound insulation as well as any necessary additional measures and/or limitations must be observed.

References to other documents

- For application of furring (without fire resistance) refer to System Data Sheet W61.de Knauf Vorsatzschalen (*Knauf Furring* (German only))
- Observe the Product Data Sheets of the Knauf system components

Symbols in System Data Sheet

The following symbols are used in this document:

Insulation layers

- G** Mineral wool insulation layer acc. to EN 13162 non-combustible (insulating material, e.g. from Knauf Insulation)
- S** Mineral wool insulation layer acc. to EN 13162 non-combustible melting point ≥ 1000 °C acc. to DIN 4102-17 (insulating material, e.g. from Knauf Insulation)

Intended use of Knauf systems

Please observe the following:

Caution	Knauf systems may only be used in the applications as described in the Knauf documents. In case of third-party products or components, they must be recommended or approved by Knauf. Flawless application of products/systems assumes proper transport, storage, assembly, installation and maintenance.
----------------	---

General instructions

Insulation layer

Requirements for the insulation layer:

Mineral wool insulation layer acc. to EN 13162 (insulating material, e.g. from Knauf Insulation)

- Fire protection: Observe the system specifications
- Sound insulation: Length-related flow resistance acc. to EN 29053 ($r \geq 5$ kPa·s/m²)

Fire protection effect

Fire protection is effective from the room side and from the shaft cavity side for all Knauf Installation Shaft Walls.

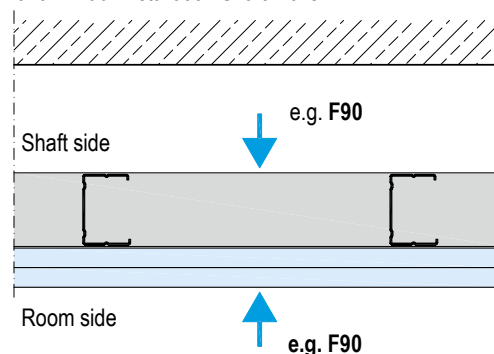

Reinforcing and supporting connection components must at least feature the same fire resistance class.

Installation zones acc. to DIN 4103-1

Installation zone 1

Partitions in rooms where low numbers of persons gather, e.g. dwellings, hotels, office and hospital rooms including corridors and halls or similar.

Installation zone 2

Partitions in rooms where large numbers of persons gather, e.g. meeting halls, school classrooms, auditoria, exhibition halls and sales rooms as well as rooms with similar usages.

Unless otherwise stated, the value in the table is the maximum permissible partition height for installation zone 2.

Construction notes

Movement joints

Movement joints of the main structure should be integrated into the construction of the installation shaft walls. Movement joints are to be installed about every 15 m on continuous installation shaft walls.

Notes on sound insulation

R_w = Weighted sound reduction index in dB without sound transmission via flanking building components

Index R = Used to differentiate between the calculation value and the test stand values.

Note	The verification according to the new DIN 4109-2:2018-01 is no longer according to calculation values $R_{w,R}$ but rather with the values obtained on the test rig R_w rounded off to a single position following the decimal point. Only at the end of the forecast after consideration of all the perimeter surfaces (flanking surfaces) involved in the transmission of sound is an element of forecast uncertainty included in dependence on the type of separating constructional component. For a transition period the Knauf System data sheets will specify both the test stand values as well as the calculated values used up to now.
-------------	--

Note	Avoid air leaks. For deflection heads, sealing with permanently elastic sealant material (recommendation: Knauf Insulation LDS Solimur) may be necessary.
-------------	---

Certificate of usability

Knauf system	Fire protection	Sound insulation	Structural engineering Taking the respective fire protection abP (National Technical Test Certificate) into consideration
W628A.de	AbP P-3969/2222-MPA BS	Knauf sound insulation proof L 020-08.09	Knauf calculation
W630.de	AbP P-3969/2222-MPA BS	Knauf sound insulation proof L 020-08.09	Knauf calculation
W628B.de	AbP P-3393/172/08-MPA BS AbP P-SAC-02/III-797	Knauf sound insulation proof L 020-08.09	AbP P-1403/355/12-MPA BS AbP P-1100/490/15-MPA BS
W629.de	AbP P-3393/172/08-MPA BS AbP P-SAC-02/III-797	Knauf sound insulation proof L 020-08.09	AbP P-1403/355/12-MPA BS AbP P-1100/490/15-MPA BS
K251.de	AbP P-3393/172/08-MPA BS	Knauf sound insulation proof L 020-08.09	AbP P-1403/355/12-MPA BS
W635.de	AbP P-3320/194/09-MPA BS	Knauf sound insulation proof L 020-08.09	Knauf calculation

Notes on fire resistance

The specifications marked with **plus** offer additional application options, which are not directly included in the Certificate of Usability. On the basis of our technical assessments, we assume that these marked design solutions can be assessed as a non-significant divergence. We can provide the documentation on which this assessment is based, such as surveyors' reports or technical assessments to you together with the Certificate of Usability on request. We recommend that a non-significant divergence be coordinated and authorised in advance in consultation between the persons responsible for fire protection and/or the relevant authorities.

The stated constructional and structural properties, and characteristic building physics of Knauf systems can solely be ensured with the exclusive use of Knauf system components, or other products expressly recommended by Knauf. The validity and up-to-datedness of the stated proofs have to be considered.

W628A.de

W630.de

W628B.de

W629.de

K251.de

W635.de

Knauf Installation Shaft Walls

Knauf Installation Shaft Walls are metal stud partitions clad on one side with a fire resistance rating, and if necessary, with a sound insulation rating providing constructional separation of installation shafts. Fire protection is provided both internally (fire in the installation shaft, protects against fire spreading to surrounding rooms) and externally (protection of the equipment as well as the spread of fire to other floors). Knauf Installation Shaft Walls consist of a metal substructure and single or double-layer cladding made of Knauf boards. The metal framework is anchored along the entire perimeter (on W628A.de only on the side) to the flanking components. Insulation material for sound and thermal insulation can be installed into the metal frame construction depending on the system insulation materials.

W628A.de Installation Shaft Wall – Free spanning

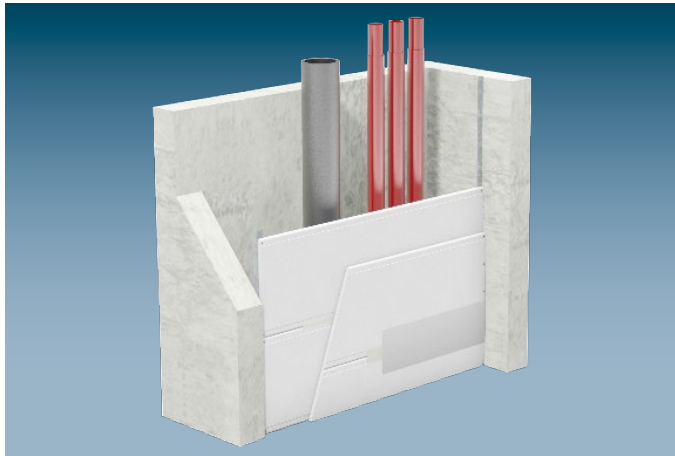

The installation shaft wall system **W628A.de** is installed up to a shaft width of 2.00 m without a stud frame. The installation shaft wall system features a slim construction. Additional insulation is not required for fire protection purposes.

- Side perimeter connections with angle profiles
- Free spanning horizontal cladding
- Wall height up to: 15.00 m
- Sound reduction index up to: 33 dB

F90

W630.de Installation Shaft Wall with stud crossbars



The installation shaft wall system **W630.de** is applied with stud crossbars up to an installation shaft width of 5.00 m. Additional insulation is not required for fire protection purposes.

- Horizontal metal crossbars, metal CW studs
- Perimeter connection with UW runners, upper and lower perimeter with CW studs
- Ball impact safety on request
- Insulation layer optional
- Horizontal cladding
(Massivbauplatte Solid Board horizontal in the 1st layer and vertical in the 2nd layer)
- Wall height up to: 15.00 m
- Sound reduction index up to: 42 dB

F30 F90

W628B.de Installation Shaft Wall with single stud profile

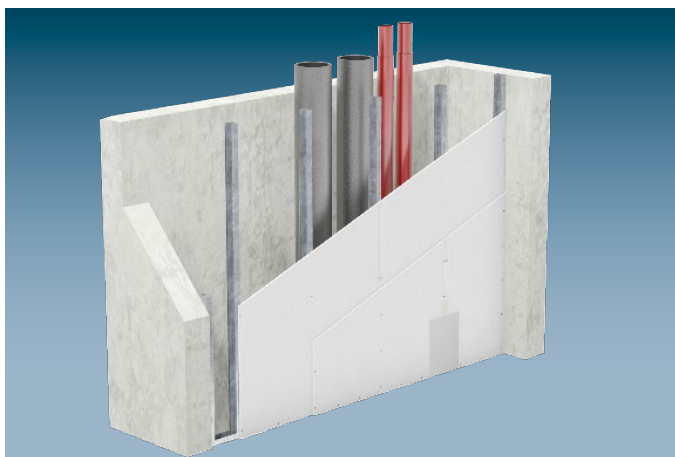

The installation shaft wall system **W628B.de** is applied using a single metal stud frame made of single profiles. Additional insulation is not required for fire protection purposes.

- Metal CW studs
- Perimeter connection with CW studs, upper and lower perimeter with UW runners
- Ball impact safety possible
- Insulation layer optional
- Vertical cladding with Feuerschutzplatte Knauf Piano fire resistant board / Knauf Feuerschutzplatte fire resistant board / Fireboard / Diamant, horizontal cladding with Massivbauplatte Solid Board / Silentboard
- Wall height up to: 7.00 m
- Sound reduction index up to: 44 dB

F30 F60 F90

W629.de Installation Shaft Wall with double stud profiles

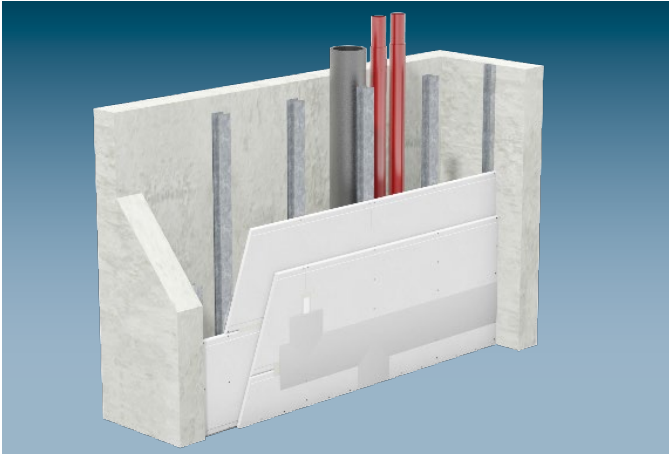

The installation shaft wall system **W629.de** is applied using a single metal stud frame made of double profiles. This facilitates particularly slim solutions.

- CW metal stud as a double profile
- Perimeter connection with CW studs, upper and lower perimeter with UW runners
- Ball impact safety possible
- Insulation layer optional depending on the system variant
- Vertical cladding with Feuerschutzplatte Knauf Piano fire resistant board / Knauf Feuerschutzplatte fire resistant board / Fireboard / Diamant, horizontal cladding with Massivbauplatte Solid Board / Silentboard
- Wall height up to: 7.00 m
- Sound reduction index up to: 44 dB

F30 F60 F90

K251.de Fireboard Installation Shaft Wall with double stud profiles



The installation shaft wall system **K251.de** features premium fire protection properties with reaction to fire A1, non-combustible and single-layer cladding made of Knauf Fireboard.

- Metal stud partition CW as a double profile without/with Fireboard covering strips on the shaft side
- Perimeter connection with CW studs, upper and lower perimeter with UW runners
- Ball impact safety on request
- Insulation layer required
- Vertical cladding
- Wall height up to: 5.00 m
- Sound reduction index up to: 39 dB

F90

W635.de Installation Shaft Wall with double stud profiles

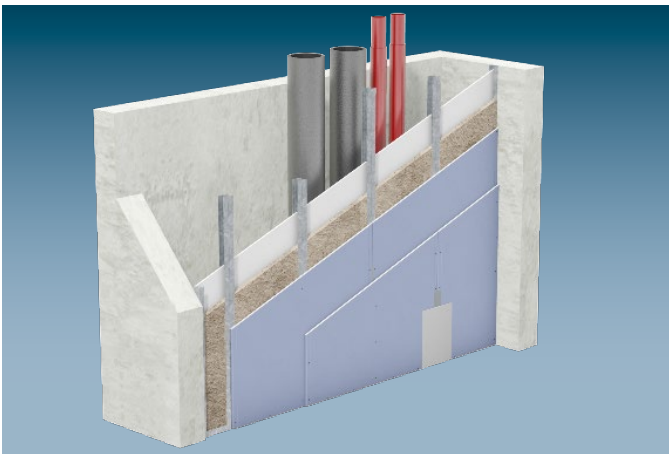

The installation shaft wall system **W635.de** is specially designed for sound installation requirements as a slim system with specially constructed additional board layer on the shaft side.

- Metal stud partition UW as a double profile with installed 12.5 mm layer of Feuerschutzplatte Knauf Piano fire resistant board on the shaft side.
- Surrounding perimeter connections with UW runners
- Ball impact safety on request
- Insulation layer required
- Vertical cladding
- Wall height up to: 5.00 m
- Sound reduction index up to: 52 dB

F90

System variants

Without substructure, free-spanning across shaft width – double-layer cladding

Knauf system	Fire resistance class	Cladding					Weight	Wall thickness	Knauf Angle Profile 50/35	Insulation layer		Sound insulation	
		Feuerschutzplatte Knauf Piano	Knauf fire resistant board	Massivbauplatte Solid Board	Fireboard	Diamant				Silentboard	Fire protection resistance permissible	Min. thickness	Min. density
Scheme drawings						Min. thickness t mm	Without insulation layer approx. kg/m ²	D mm	h mm	mm	kg/m ³		

W628A.de Installation Shaft Wall – free-spanning Without substructure, free-spanning across shaft width – double-layer cladding

	F90		•			2x 25	46	50	—	Without		36	33
--	-----	--	---	--	--	-------	----	----	---	---------	--	----	----

Note Observe the notes on page 4.

Wall heights

1-sided application

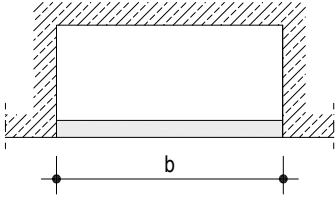
Knauf perimeter runner	Maximum shaft width	Partition height maximum permissible	Increased wall heights maximum permissible plus
			
Angle Profile 50/35 Alternative CW stud or UW runner possible	2.00 m	3.00 m	15.00 m

plus 2-sided application

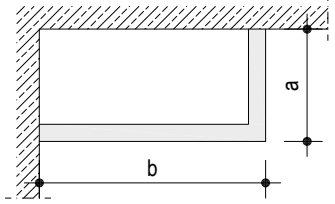
Knauf perimeter runner	Maximum installation shaft wall surface execution	Maximum permissible wall height
		
Angle Profile 50/35 Alternative CW stud or UW runner possible	$a + b \leq 2.00 \text{ m}$	5.00 m

plus 3-sided application

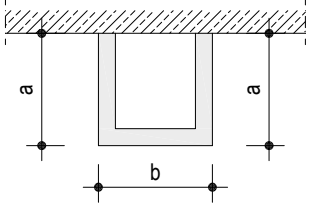
Knauf perimeter runner	Maximum installation shaft wall surface execution	Maximum permissible wall height
		
Angle Profile 50/35 Alternative CW stud or UW runner possible	$2 a + b \leq 2.00 \text{ m}$	5.00 m

plus Extension of the fire resistance Certificate of Usability

- In case wall heights exceeding 3.00 m are used
 - With 2- or 3-sided application
- Prior consultation in acc. to page 5 is recommended.

Note

Maximum permissible spacings with edge fixing see page 40.

System variants

Metal crossbars with CW Studs, double-layer cladding

Knauf system	Fire resistance class	Cladding					Weight	Wall thickness	Profile	Insulation layer	Sound insulation																																								
		Feuerschutzplatte	Knauf Piano	Knauf fire resistant board	Massivbauplatte	Solid Board					Fireboard	Diamant	Silentboard	Min. thickness	Without insulation layer approx.	D	h	Cavity	Fire protection resistance permissible	Min. thickness	Min. density	Minimum insulation layer thickness																													
Scheme drawings						t	mm	kg/m ²	mm	mm	mm	mm	mm	mm	mm	mm	mm	mm	R _w	R _{w,R}	R _w	R _{w,R}	R _w	R _{w,R}	R _w	R _{w,R}																									
	F30	•				2x 12.5	26	75	50	Without or mineral wool	G plus	32	30	38	36	38	36	≥ 38	≥ 36																																
																										100	75																								
																										125	100																								
																										75	50			•	2x 12.5	30	75	50	Without or mineral wool	G plus	34	31	39	37	≥ 39	≥ 37	43	40							
																										100	75																								
																										125	100																								
	F90	•				2x 20	40	90	50	Without or mineral wool	G plus	35	33	43	41	44	42	≥ 44	≥ 42																																
								115	75																																										
								140	100																																										

Sound reduction index values represented in italics are derived values from measurements on divergent constructions.

plus Extension of the fire resistance Certificate of Usability

- When applied with insulation layer **G**
- Prior consultation in acc. to page 5 is recommended.

Note Observe the notes on page 4.

Wall heights

Double-layer cladding, Feuerschutzplatte Knauf Piano fire resistant board / Diamant 2x 12.5 mm

Knauf profile	Maximum crossbar spacing	Shaft widths maximum permissible	Maximum permissible increased shaft widths plus	Wall heights maximum permissible	Increased wall heights maximum permissible plus
Metal gauge 0.6 mm	mm	m	m	m	m
CW 50	312.5	3.00	3.00	3.00	15.00
CW 75	312.5	3.00	4.50	3.00	15.00
CW 100	312.5	3.00	5.00	3.00	15.00

Double-layer cladding, Massivbauplatte Solid Board 2x 20 mm

Knauf profile	Maximum crossbar spacing	Shaft widths maximum permissible	Maximum permissible increased shaft widths plus	Wall heights maximum permissible	Increased wall heights maximum permissible plus
Metal gauge 0.6 mm	mm	m	m	m	m
CW 50	312.5 ¹⁾	3.00	3.00	3.00	15.00
CW 75	312.5 ¹⁾	4.00	4.50	3.00	15.00
CW 100	312.5 ¹⁾	4.00	5.00	3.00	15.00

1) Alternative crossbar spacing 625 mm possible with CW double profile possible up to shaft width 4.00 m and shaft height 3.00 m

Crossbar frame spacing

■ CW profile as crossbar

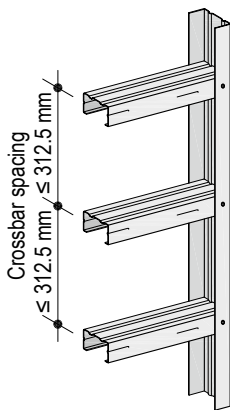

■ CW double profile as crossbar

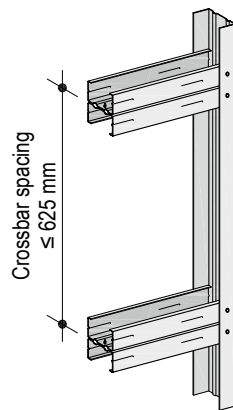

CW double profile preferred variant with installation of insulation layer



Extension of the fire resistance Certificate of Usability

- In case the enhanced shaft widths are used
 - In case the enhanced wall heights are used
- Prior consultation in acc. to page 5 is recommended.

Note

Maximum permissible spacings with edge fixing see page 40.

System variants

Single metal stud frame with CW single studs, double-layer cladding

Knauf system	Fire resistance class	Cladding					Weight Without insula- tion layer approx. kg/m ²	Wall thick- ness		Pro- file Knauf CW	Insulation layer		Sound insulation									
		Feuerschutzplatte Knauf Plano	Knauf fire resistant board	Massivbauplatte Solid Board	Fireboard	Diamant		Silentboard	Min. thick- ness t mm		D mm	h mm	Fire protection resistance permissible Min. thick- ness mm	Min. den- sity kg/m ³	Minimum insulation layer thickness							
															—	40 mm	60 mm	80 mm	R _w dB	R _{w,R} dB	R _w dB	R _{w,R} dB
	F30	•				2x 12.5	25	75	50	Without or mineral wool G plus		32	30	38	36	38	36	≥ 38	≥ 36			
								100	75													
								125	100													
								75	50													
								100	75													
								125	100													
	F30 plus	•				2x 12.5	40	75	50	Without or mineral wool G plus		38.4	36	42.9	40	44.8	42	46.8	44			
								100	75													
								125	100													
								75	50													
								100	75													
								125	100													
F60	•				2x 15	29	80	50	Without or mineral wool G plus		32	30	38	36	38	36	≥ 38	≥ 36				
							105	75														
							130	100														
							80	50														
							105	75														
							130	100														
F90 plus	•				2x 20	39	90	50	Without or mineral wool G plus		35	33	43	41	44	42	≥ 44	≥ 42				
							115	75														
							140	100														
							90	50														
							115	75														
							140	100														
F90	•				2x 25	47	100	50	Without or mineral wool G plus		36	33	43	41	44	42	≥ 44	≥ 42				
							125	75														
							150	100														
							100	50														
							125	75														
							150	100														
F90	•				2x 20	36	115	75	Without or mineral wool G plus		35	33	43	41	44	42	≥ 44	≥ 42				
							140	100														
							115	75														
							140	100														
							115	75														
							140	100														

Sound reduction index values represented in italics are derived values from measurements on divergent constructions.

plus Extension of the fire resistance Certificate of Usability

- When applied with insulation layer **G**
 - For variant with Silentboard
- Prior consultation in acc. to page 5 is recommended.

Note Observe the notes on page 4.

Wall heights

Installation zones 1 and 2

Knauf profile	Max. spacings a	Maximum permissible wall height							
		Feuer-schutzplatte Knauf Piano fire resistant board 2x 12.5 mm	Diamant 2x 12.5 mm	Silentboard 2x 12.5 mm	Knauf Feuer-schutzplatte fire resistant board 2x 15 mm	Diamant 2x 15 mm	Mas-sivbauplatte Solid Board 2x 20 mm	Fireboard 2x 20 mm	Mas-sivbauplatte Solid Board 2x 25 mm
Metal gauge 0.6 mm	mm	m	m	m	m	m	m	m	m
Double-layer cladding									
CW 50	1000	–	–	–	–	–	–	–	3.00 ¹⁾
	625	2.95 ¹⁾	2.95 ¹⁾	–	3.00 ¹⁾	3.00 ¹⁾	–	–	3.00
	312.5	3.00	3.00	–	3.00	3.00	–	–	3.00
CW 75	1000	–	–	–	–	–	–	–	3.00
	625	3.00	3.00	–	3.00	3.00	–	3.00	3.00
	312.5	3.00	3.00	–	3.00	3.00	–	3.00	3.00
CW 100	1000	–	–	–	–	–	–	–	3.00
	625	3.00	3.00	–	3.00	3.00	–	3.00	3.00
	312.5	3.00	3.00	–	3.00	3.00	–	3.00	3.00
plus Increased wall heights, double-layer cladding									
CW 50	1000	–	–	–	–	–	2.70	2.70	3.10
	625	2.95	2.65 / 3.35 ¹⁾	2.65 / 3.35 ¹⁾	3.10	3.25	2.80 / 3.55 ¹⁾	2.80 / 3.55 ¹⁾	4.00
	417	3.20	4.00	4.00	3.80	4.00	4.00	4.00	4.00
	312.5	4.00	4.00	4.00	4.00	4.00	4.00	4.00	4.05
CW 75	1000	–	–	–	–	–	3.95	3.95	4.00
	625	4.00	4.00	4.00	4.00	4.00	4.00	4.00	4.05
	417	4.00	4.40	4.40	4.15	4.65	4.55	4.55	5.00
	312.5	4.55	4.95	4.95	4.75	5.25	5.20	5.20	5.70
CW 100	1000	–	–	–	–	–	4.00	4.00	4.10
	625	4.50	4.95	4.95	5.20	5.20	5.00	5.00	5.40
	417	5.40	5.90	5.90	6.20	6.20	6.10	6.10	6.60
	312.5	6.15	6.65	6.65	6.95	6.95	6.90	6.90	7.00

1) only for installation zone 1

With wall height > 3.00 m

Construction of edge fixing

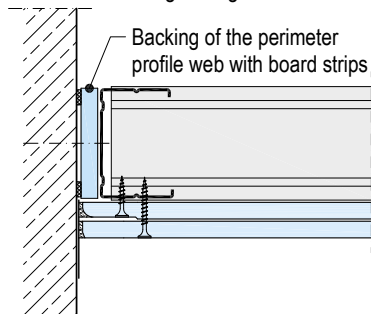

See page 25 and page 40.

Ball impact safety

Ball impact safety is provided with spacing of studs ≤ 625 mm.

plus Extension of the fire resistance Certificate of Usability

- In case the enhanced wall heights are used Prior consultation in acc. to page 5 is recommended.

Note

Maximum permissible spacings with edge fixing see page 40.

Wall heights

Installation zones 1 and 2

Knauf profile	Max. spacings a	Maximum permissible wall height								
		Feuer-schutzplatte Knauf Piano fire resistant board 2x 12.5 mm	Diamant 2x 12.5 mm	Silentboard 2x 12.5 mm	Knauf Fire Resistant Board 2x 15 mm	Diamant 2x 15 mm	Massivbau-platte Solid Board 2x 20 mm	Fireboard 2x 20 mm	Massivbau-platte Solid Board 2x 25 mm	
Metal gauge 0.6 mm	mm	m	m	m	m	m	m	m	m	
Double-layer cladding										
CW 50	1000	–	–	–	–	–	–	–	–	3.00
	625	3.00	3.00	–	3.00	3.00	–	3.00	3.00	3.00
	312.5	3.00	3.00	–	3.00	3.00	–	3.00	3.00	3.00
CW 75	1000	–	–	–	–	–	–	–	–	3.00
	625	3.00	3.00	–	3.00	3.00	–	3.00	3.00	3.00
	312.5	3.00	3.00	–	3.00	3.00	–	3.00	3.00	3.00
CW 100	1000	–	–	–	–	–	–	–	–	3.00
	625	3.00	3.00	–	3.00	3.00	–	3.00	3.00	3.00
	312.5	3.00	3.00	–	3.00	3.00	–	3.00	3.00	3.00
plus Increased wall heights, double-layer cladding										
CW 50	1000	–	–	–	–	–	3.95	3.95	4.00	4.00
	625	4.00	4.00	4.00	4.00	4.00	4.00	4.00	4.00	4.05
	312.5	4.05	4.45	4.45	4.30	4.75	4.80	4.80	4.80	5.45
CW 75	1000	–	–	–	–	–	4.15	4.15	4.15	4.55
	625	4.55	4.95	4.95	4.75	5.25	5.20	5.20	5.20	5.70
	312.5	6.00	6.45	6.45	6.30	6.80	6.90	6.90	6.90	7.00
CW 100	1000	–	–	–	–	–	5.60	5.60	5.60	6.00
	625	6.15	6.65	6.65	6.40	6.95	6.90	6.90	6.90	7.00
	312.5	7.00	7.00	7.00	7.00	7.00	7.00	7.00	7.00	7.00

With wall height > 3.00 m

Construction of edge fixing

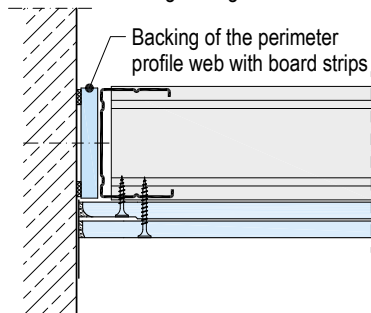

See page 27 and page 40.

Ball impact safety

Ball impact safety is provided with spacing of studs ≤ 625 mm.

Extension of the fire resistance Certificate of Usability

- In case the enhanced wall heights are used Prior consultation in acc. to page 5 is recommended.

Note

Maximum permissible spacings with edge fixing see page 40.

System variants

Single metal stud frame with CW double stud frame, single-layer cladding

Knauf system	Fire resistance class	Cladding					Weight	Wall thickness	Profile Knauf CW	Insulation layer		Sound insulation				
		Feuerschutzplatte Knauf Piano	Knauf fire resistant board	Massivbauplatte Solid Board	Fireboard	Diamant				Silentboard	Min. thickness	Without insulation layer approx. kg/m ²	Cavity	Min. thickness	Min. density	Minimum insulation layer thickness
Scheme drawings						t mm	D mm	h mm	mm	kg/m ³	40 mm	60 mm	R _w dB	R _{w,R} dB	R _w dB	R _{w,R} dB
K251.de Fireboard Installation Shaft Wall height ≤ 3.00 m Single metal stud frame with CW double stud frame, single-layer cladding																
<p>Wall height: ≤ 3.00 m</p>	F90					30	31	80	50	Mineral wool 40 40	S	40	38	41	39	
									105							75
									130							100
plus K251.de Fireboard Installation Shaft Wall height > 3.00 m to 5.00 m Single metal stud frame with CW double stud frame, single-layer cladding																
<p>Wall height > 3.00 m</p>	F90					30 + 12.5 Stud covering	32	92.5	50	Mineral wool 40 40	S	40	38	41	39	
									117.5							75
									142.5							100

Apply backing to front edge joints using profiles or Fireboard strips

plus Extension of the fire resistance Certificate of Usability

- With wall heights exceeding 3.00 m
- Prior consultation in acc. to page 5 is recommended.

Note

Observe the notes on page 4.

Wall heights

Single-layer cladding

Knauf profile	Maximum spacings a	Wall heights maximum permissible	Increased wall heights maximum permissible plus
Metal gauge 0.6 mm	mm	m	m
CW 50	625	3.00	4.00
CW 75	625	3.00	4.50
CW 100	625	3.00	5.00

Type with stud covering

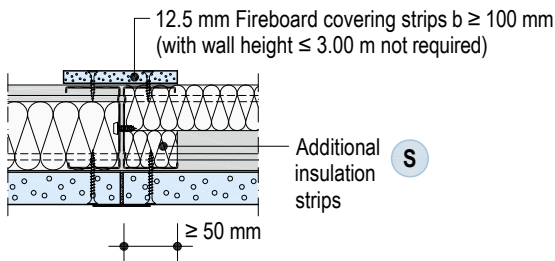

Extension of the fire resistance Certificate of Usability

- In case the enhanced wall heights are used
Prior consultation in acc. to page 5 is recommended.

Note

Maximum permissible spacings with edge fixing see page 40.

System variants

Single metal stud frame with UW double runners, double-layer cladding + intermediate board layer

Knauf system	Fire resistance class	Cladding					Weight	Wall thickness	Profile Knauf CW	Insulation layer		Sound insulation					
		Feuerschutzplatte Knauf Piano	Knauf fire resistant board	Massivbauplatte Solid Board	Fireboard	Diamant				Silentboard	Min. thickness	Without insulation layer approx. kg/m ²	Cavity	Min. thickness	Min. density	Minimum insulation layer thickness	
Scheme drawings						t mm		D mm	h mm	mm	kg/m ³	40 mm	80 mm	R _w dB	R _{w,R} dB	R _w dB	R _{w,R} dB
W635.de Installation Shaft Wall		Single metal stud frame with UW double runners, double-layer cladding + intermediate board layer															
	F90	•				•	2x 15 + 12.5 intermediate	46	80	50		Mineral wool 40	30	49	47	54	52
									105	75							
									130	100							

Note Observe the notes on page 4.

Wall heights

Double-layer cladding + intermediate board layer

Knauf profile	Maximum spacings a	Wall heights maximum permissible	Maximum permissible increased wall heights
Metal gauge 0.6 mm	mm	m	plus m
UW 50	625	3.00	4.00
UW 75	625	3.00	4.50
UW 100	625	3.00	5.00



Extension of the fire resistance Certificate of Usability

- In case the enhanced wall heights are used
Prior consultation in acc. to page 5 is recommended.

Note

Maximum permissible spacings with edge fixing see page 40.

Details

W628A.de-P1 Horizontal board layers

2x 25 mm Massivbauplatte Solid Board

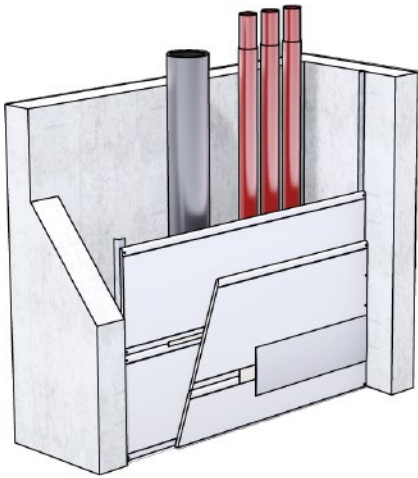

Scale 1:5

W628A.de-VO1 Connection to ceiling

Vertical section

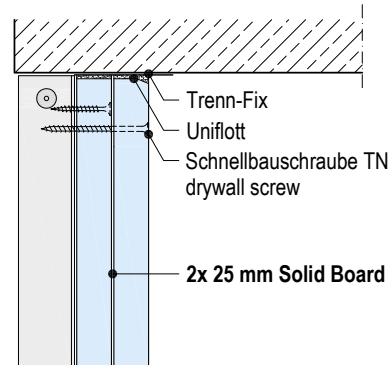

W628A.de-VM1 Board joint

Vertical section

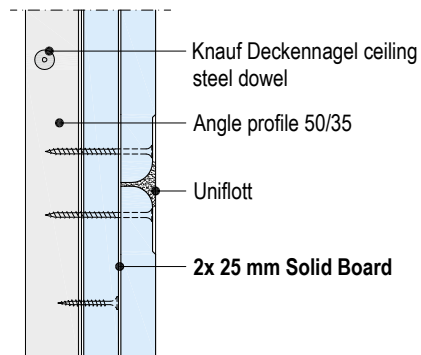

W628A.de-VU1 Connection to floor

Vertical section

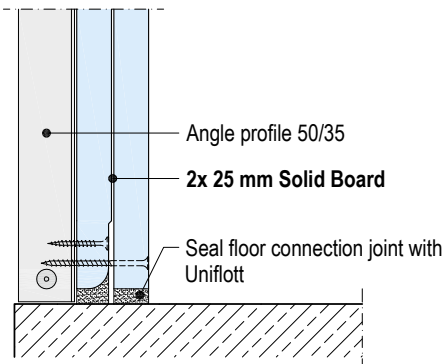

W628A.de
W630.de
W628B.de
W629.de
K251.de
W635.de

Details

W628A.de-A1 Connection to solid wall

Horizontal section

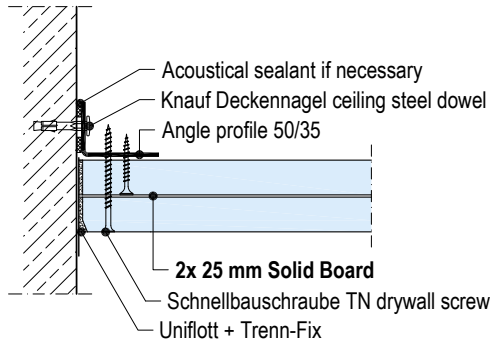

W628A.de-D1 Corner

Horizontal section

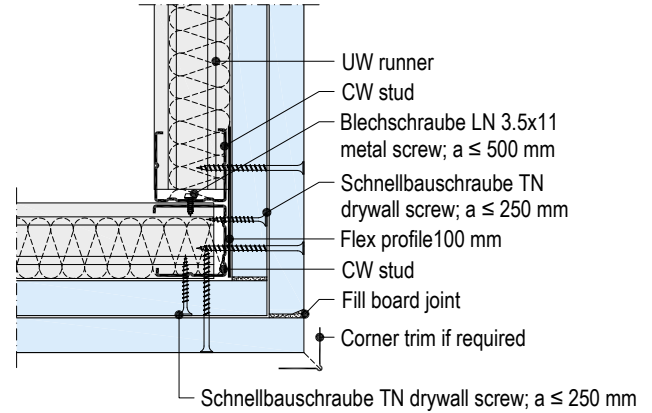

Maximum permissible wall height 5.00 m

plus Extension of the fire resistance Certificate of Usability
Prior consultation in acc. to page 5 recommended

W628A.de-D2 Corner

Horizontal section

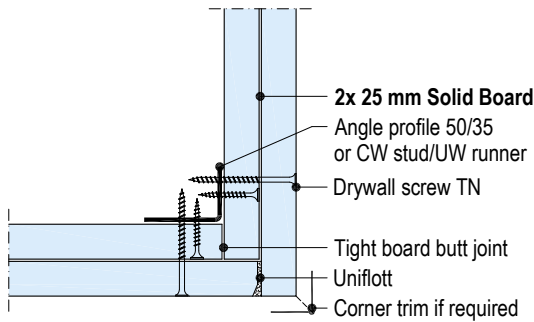

■ Simplified corner detail maximum wall heights see table

plus Extension of the fire resistance Certificate of Usability
Prior consultation in acc. to page 5 recommended

plus Internal dimension clearance maximum permissible for
Installation Shaft Walls with simplified corner detail
(e.g.: W628A.de-D2 Corner)

Applica- tion	Maximum dimensions		Maximum installation shaft wall surface execution mm	Maximum permissible wall height m
	a	b		
	mm	mm		
1-sided	500	500	$a + b \leq 500$	4.00
2-sided	500	500	$a + b \leq 750$	4.00
3-sided	500	500	$a + b \leq 1000$	3.00

Example: Internal dimensioning with 2-side application

Scheme drawing

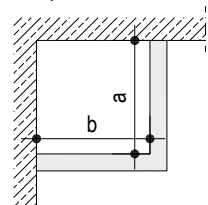

Details

Scale 1:5

W630.de-P1 Horizontal board layers

2x 12.5 mm Feuerschutzplatte Knauf Piano fire resistant board / Diamant

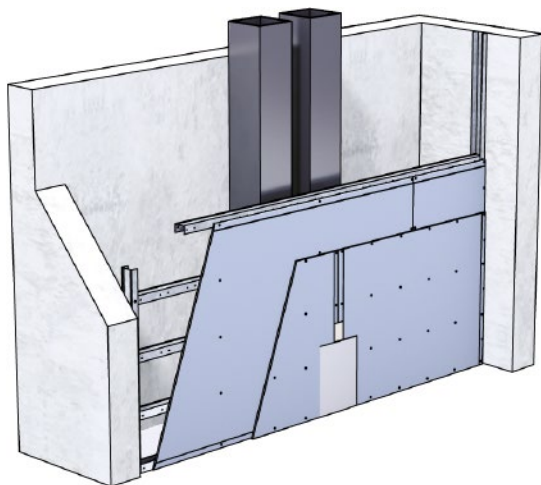

W630.de-VO1 Connection to ceiling

Vertical section

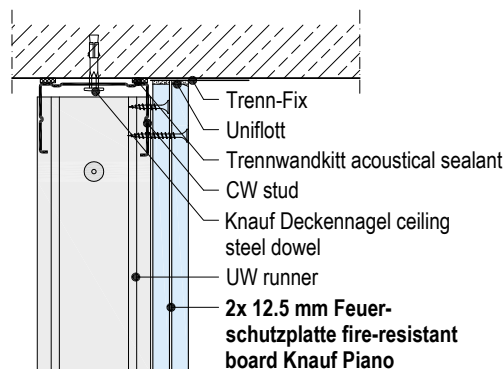

W630.de-P4 Board layer 1 horizontal, board layer 2 vertical

2x 20 mm Massivbauplatte Solid Board

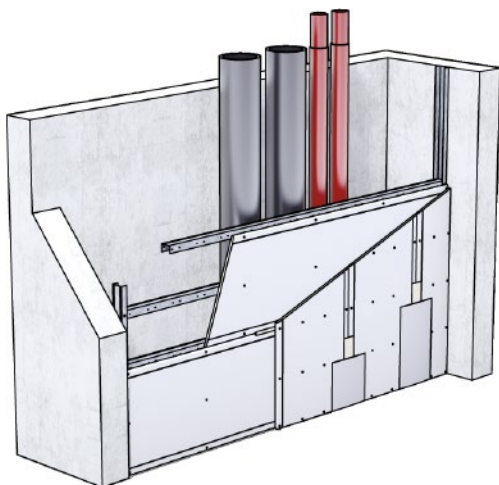

W630.de-VM4 Board joint CW double profile

Vertical section

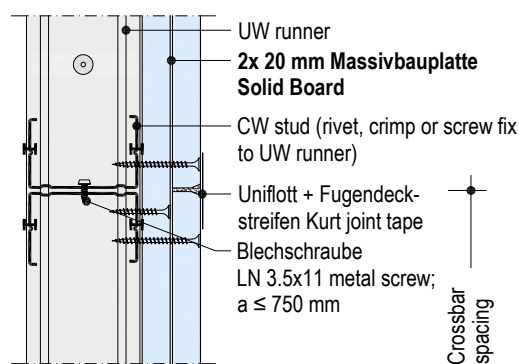

W630.de-VU4 Connection to floor

Vertical section

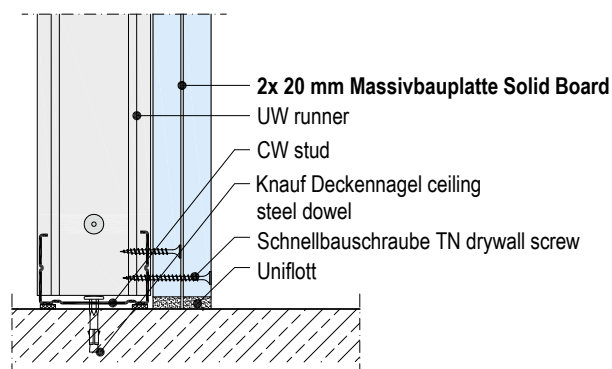

Note Installation of an access panel is possible. Application in accordance with the Knauf Access Panel product data sheets.

Details

W630.de-A1 Connection to solid wall

Horizontal section

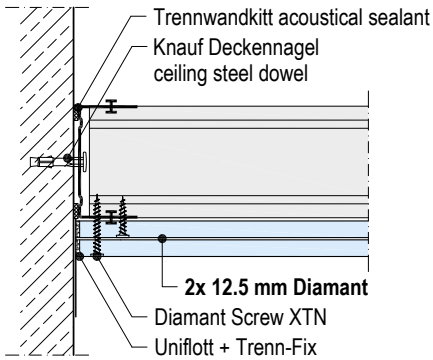

W630.de-B4 Board joint

Horizontal section

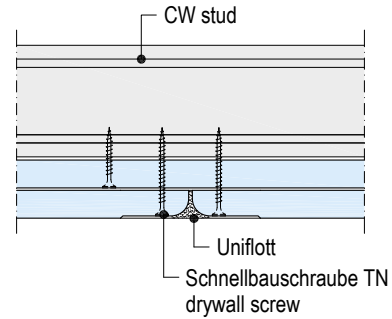

W630.de-VM1 Board joint CW single profile

Vertical section

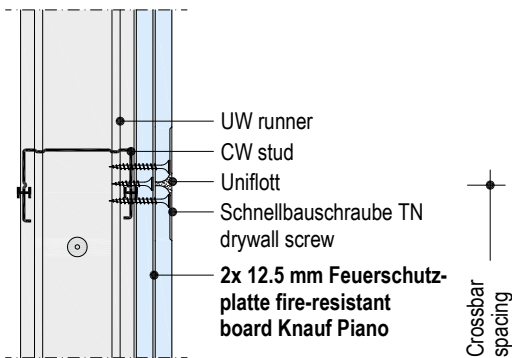

Note

Installation of an access panel is possible. Application in accordance with the Knauf Access Panel product data sheets.

Details

Scale 1:5

W628B.de-P2 Vertical board layers

e.g. 2x 12.5 mm Feuerschutzplatte Knauf Piano fire resistant board / Diamant

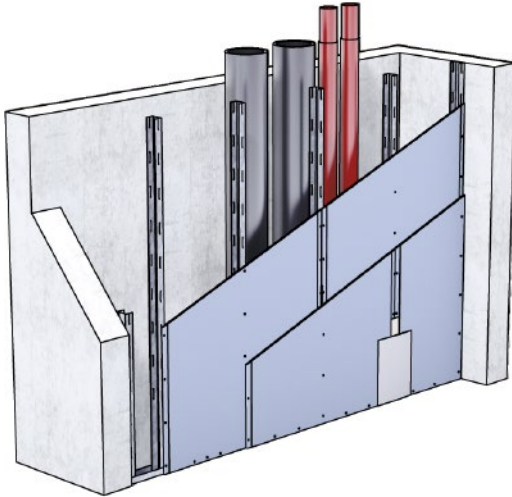

W628B.de-VO2 Connection to ceiling

Vertical section

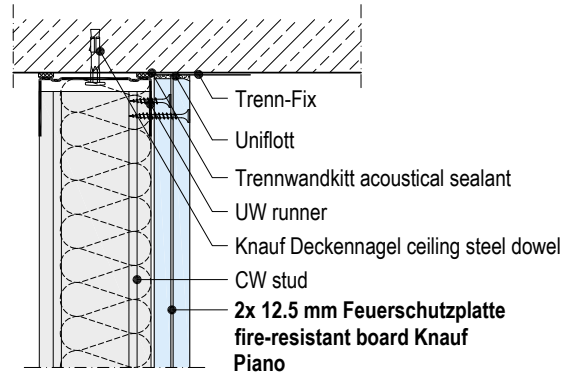

W628B.de-P6 Horizontal board layers

e.g. 2x 20 mm Massivbauplatte Solid Board

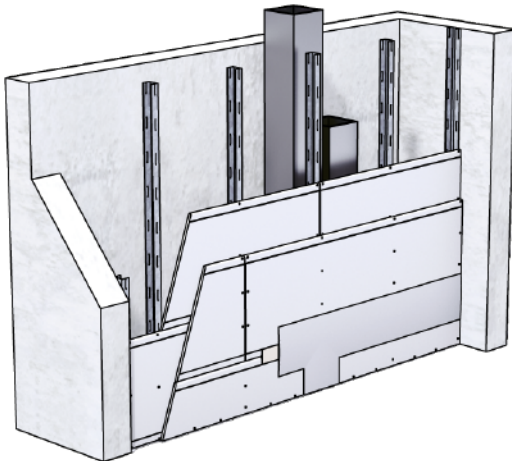

W628B.de-VM6 Board joint

Vertical section

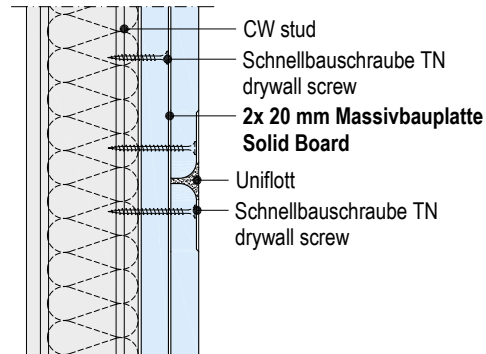

plus Extension of the fire resistance Certificate of Usability
Prior consultation in acc. to page 5 recommended.

W628B.de-P4 Vertical board layers

e.g. 2x 20 mm Fireboard

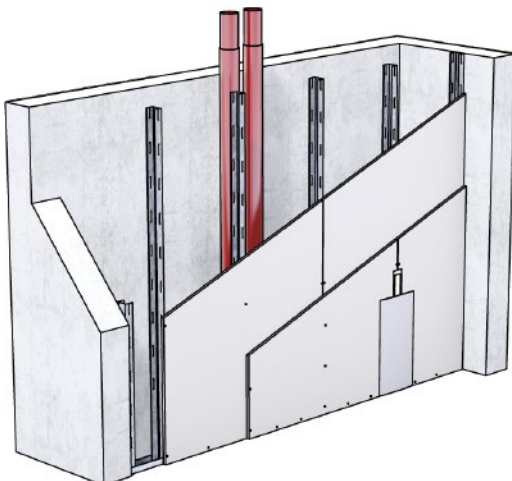

W628B.de-VU4 Connection to floor

Vertical section

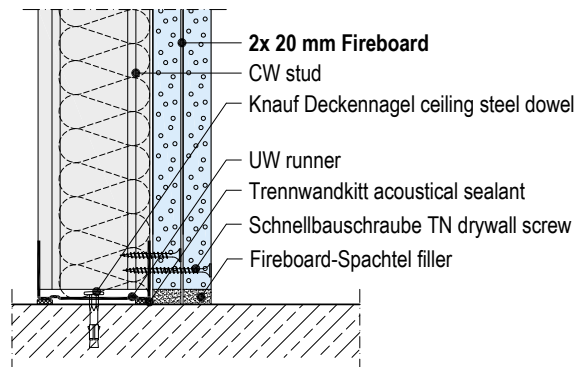

Note Installation of an access panel is possible. Application in accordance with the Knauf Access Panel product data sheets.

Details

W628B.de-A2 Connection to solid wall

Horizontal section

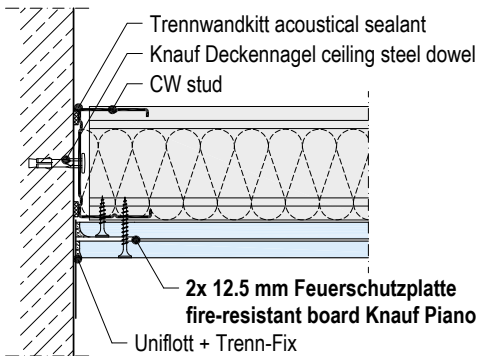

With wall height ≤ 3.00 m no backing of the CW perimeter connection profile on the web side required.

W628B.de-A21 Connection to solid wall

Horizontal section

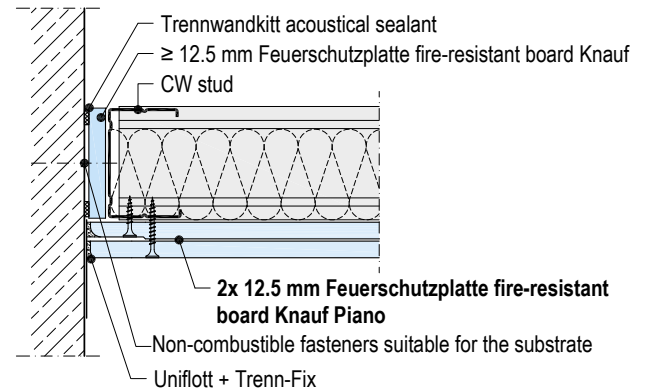

With wall height > 3.00 m backing of the CW perimeter connection profile on the web side required.

plus Extension of the fire resistance Certificate of Usability
Prior consultation in acc. to page 5 recommended.

W628B.de-A3 Connection to solid wall

Horizontal section

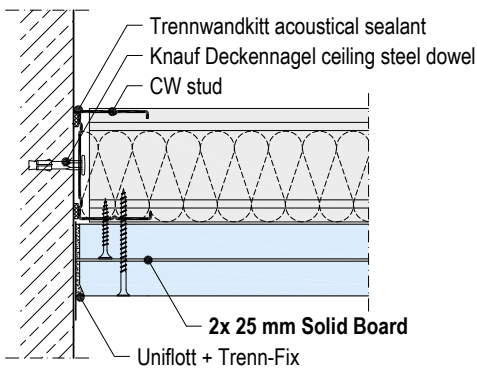

With wall height ≤ 3.00 m no backing of the CW perimeter connection profile on the web side required.

W628B.de-B4 Board joint

Horizontal section

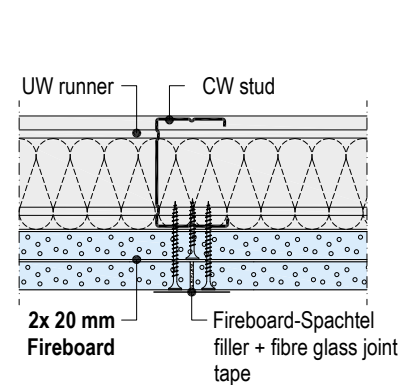

W628B.de-SO4 Connection to metal stud partition

Horizontal section

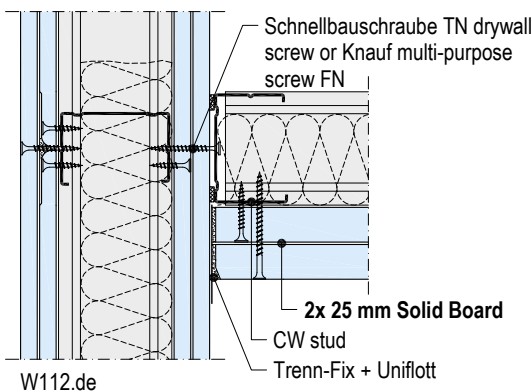

With wall height ≤ 3.00 m no backing of the CW perimeter connection profile on the web side required

plus Extension of the fire resistance Certificate of Usability
Prior consultation in acc. to page 5 recommended.

W628B.de-D3 Corner

Horizontal section

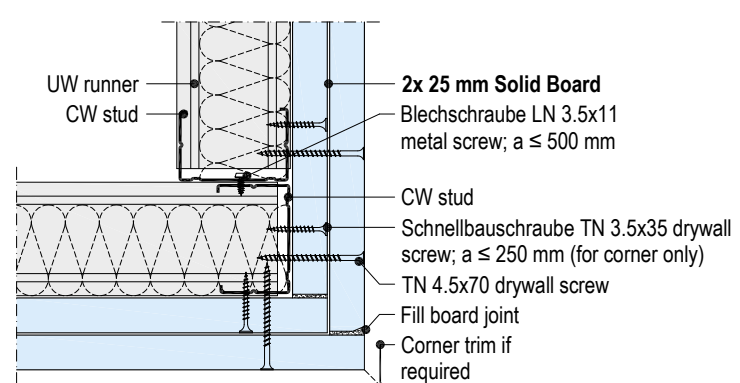

plus Extension of the fire resistance Certificate of Usability
Prior consultation in acc. to page 5 recommended.

Note Installation of an access panel is possible. Application in accordance with the Knauf Access Panel product data sheets.

Details

W629.de-P2 Vertical board layers

e.g. 2x 12.5 mm Feuerschutzplatte Knauf Piano fire resistant board / Diamant

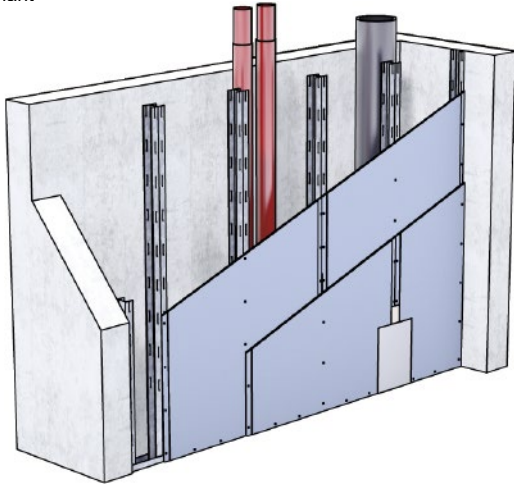

W629.de-VO2 Connection to ceiling

Vertical section

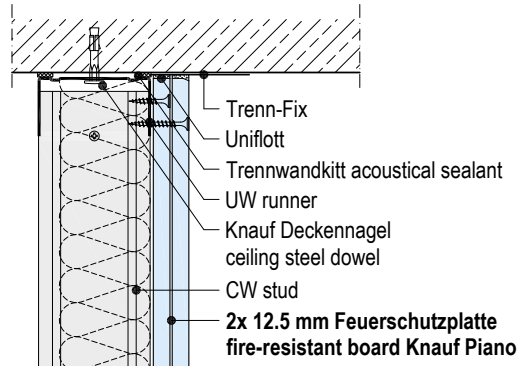

W629.de-P5 Horizontal board layers

e.g. 2x 20 mm Massivbauplatte Solid Board

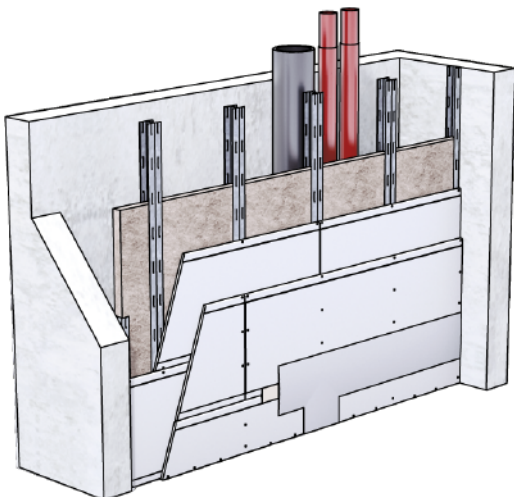

W629.de-VM5 Board joint

Vertical section

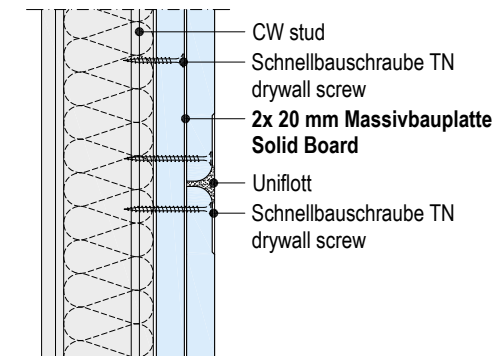

plus Extension of the fire resistance Certificate of Usability
Prior consultation in acc. to page 5 recommended

W629.de-P6 Horizontal board layers

e.g. 2x 25 mm Massivbauplatte Solid Board

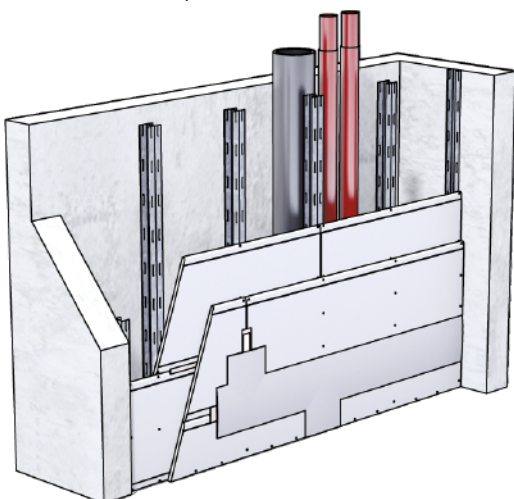

W629.de-VU6 Connection to floor

Vertical section

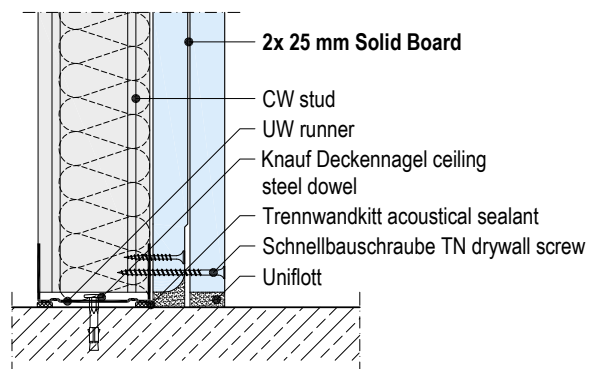

Note Installation of an access panel is possible. Application in accordance with the Knauf Access Panel product data sheets.

Details

W629.de-A2 Connection to solid wall

Horizontal section

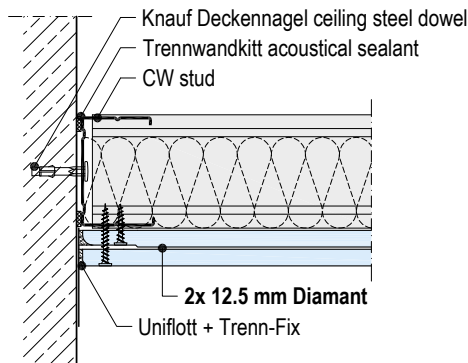

With wall height ≤ 3.00 m no backing of the CW perimeter connection profile on the web side required.

W629.de-A21 Connection to solid wall

Horizontal section

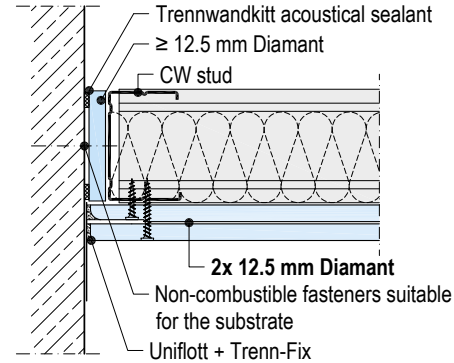

With wall height > 3.00 m backing of the CW perimeter connection profile on the web side required.

plus Extension of the fire resistance Certificate of Usability
Prior consultation in acc. to page 5 recommended

W629.de-A51 Connection to solid wall

Horizontal section

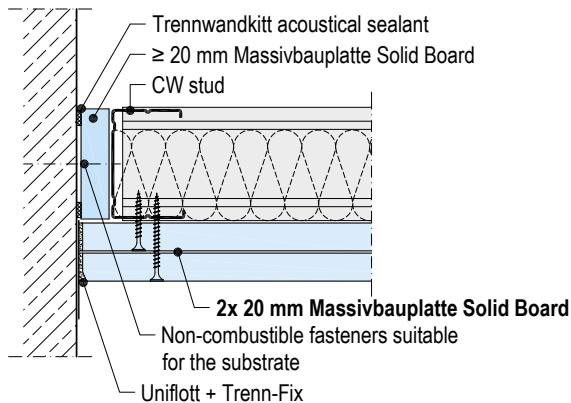

With wall height > 3.00 m backing of the CW perimeter connection profile on the web side required.

plus Extension of the fire resistance Certificate of Usability
Prior consultation in acc. to page 5 recommended

W629.de-B5 Board joint

Horizontal section

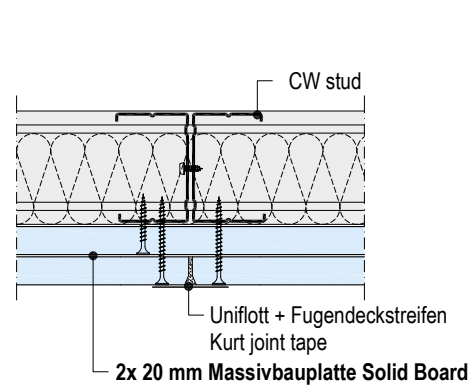

plus Extension of the fire resistance Certificate of Usability
Prior consultation in acc. to page 5 recommended

W629.de-SO5 Connection to solid wall

Horizontal section

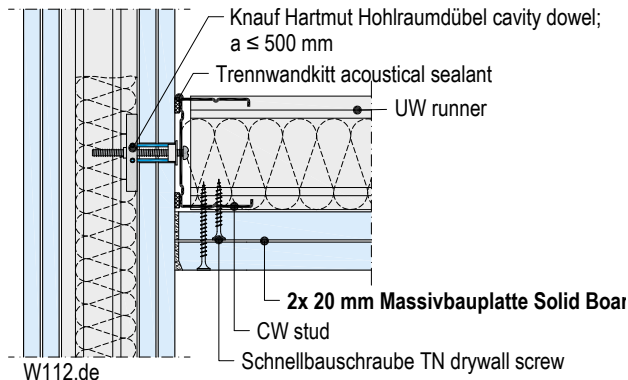

With wall height ≤ 3.00 m no backing of the CW perimeter connection profile on the web side required.

plus Extension of the fire resistance Certificate of Usability
Prior consultation in acc. to page 5 recommended

W629.de-D6 Corner

Horizontal section

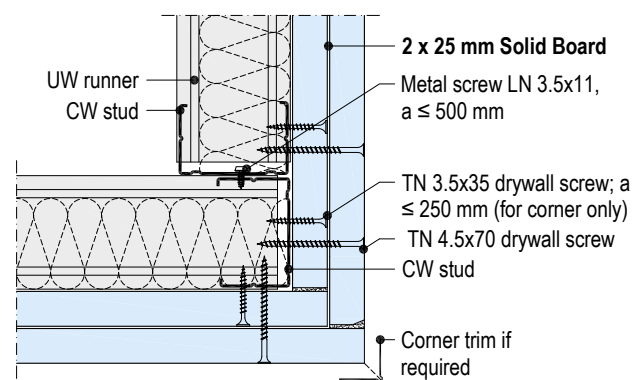

plus Extension of the fire resistance Certificate of Usability
Prior consultation in acc. to page 5 recommended

Note

Installation of an access panel is possible. Application in accordance with the Knauf Access Panel product data sheets.

W628A.de
W630.de
W628B.de
W629.de
K251.de
W635.de

Details

Scale 1:5

K251.de-P6 Vertical board layers

30 mm Fireboard

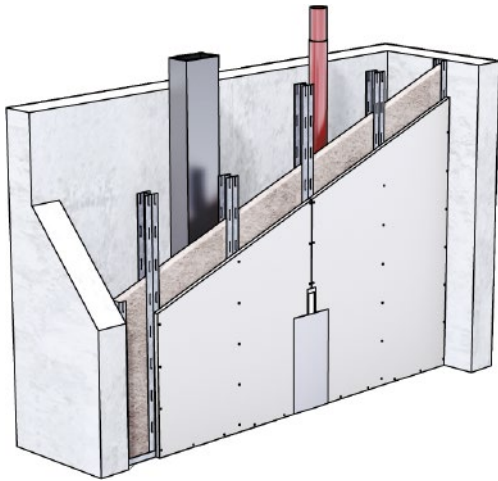

With wall height ≤ 3.00 m

K251.de-P5 Vertical board layers + stud covering

30 mm Fireboard + 12.5 mm Fireboard covering strip

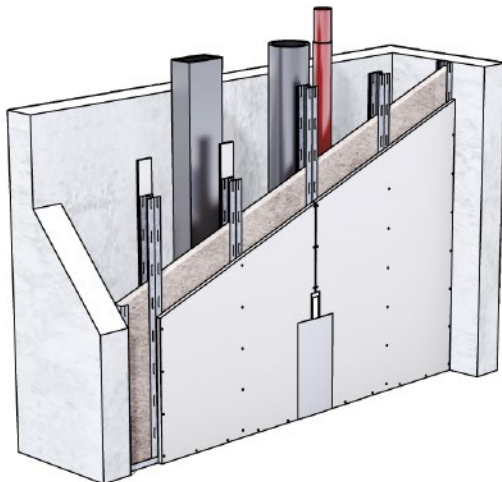

With wall height > 3.00 m

K251.de-VO6 Connection to ceiling

Vertical section

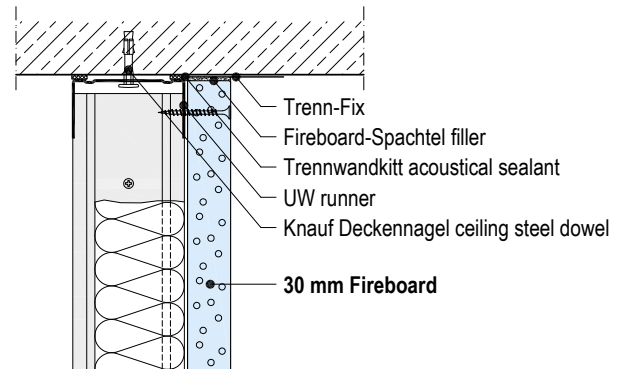

With wall height ≤ 3.00 m

K251.de-VM6 Board joint

Vertical section

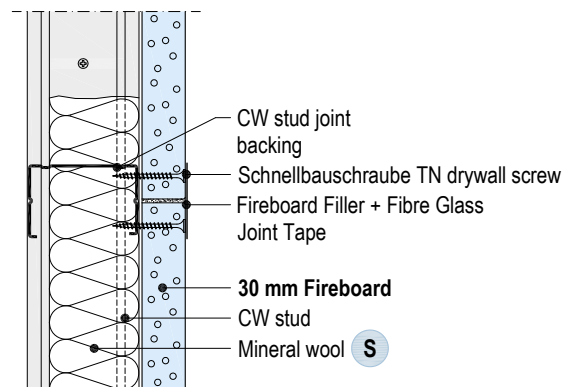

With wall height ≤ 3.00 m

K251.de-VU6 Connection to floor

Vertical section

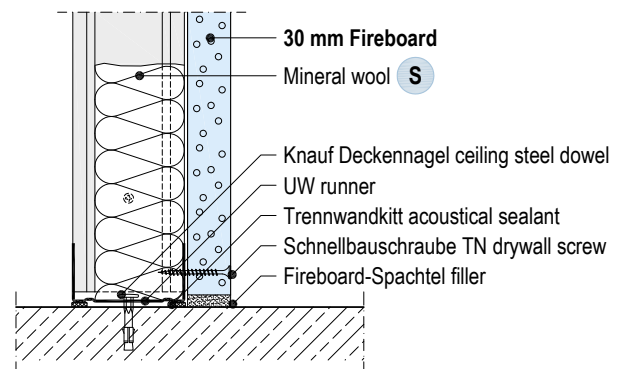

With wall height ≤ 3.00 m

Note Installation of an access panel is possible. Application in accordance with the Knauf Access Panel product data sheets.

Details

K251.de-A6 Connection to solid wall

Horizontal section

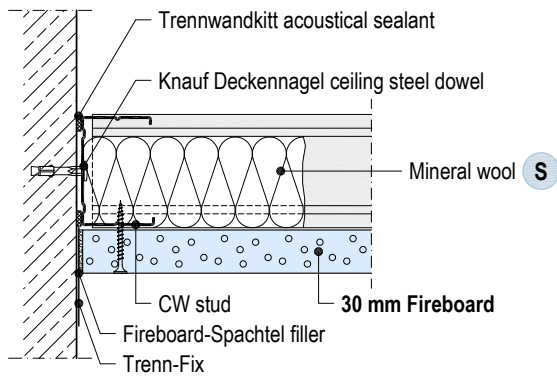

With wall height ≤ 3.00 m

K251.de-D6 Corner

Horizontal section

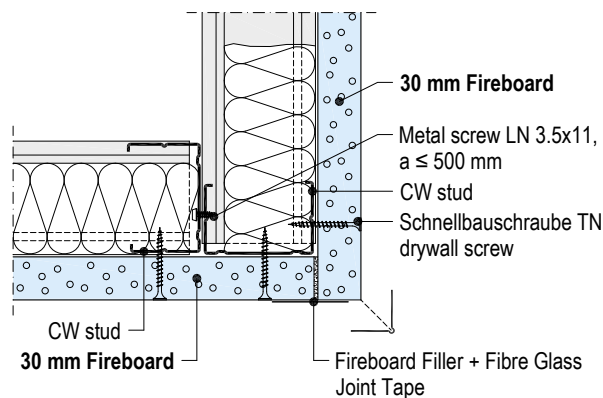

With wall height ≤ 3.00 m

plus Extension of the fire resistance Certificate of Usability
Prior consultation in acc. to page 5 recommended

K251.de-VU5 Connection to floor

Vertical section

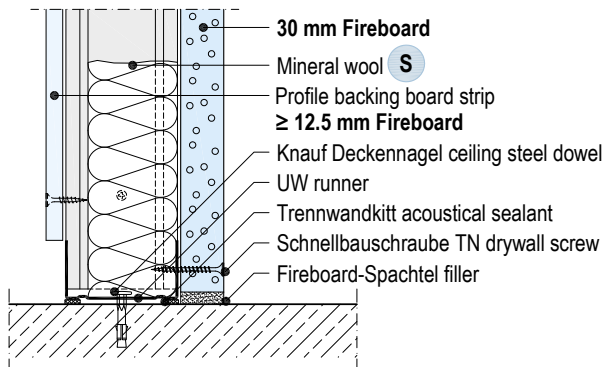

With wall height > 3.00 m

plus Extension of the fire resistance Certificate of Usability
Prior consultation in acc. to page 5 recommended

K251.de-B6 Board joint

Horizontal section

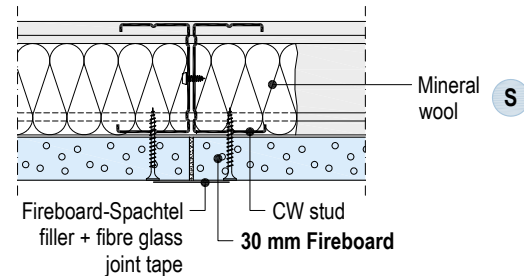

With wall height ≤ 3.00 m

K251.de-D5 Corner

Horizontal section

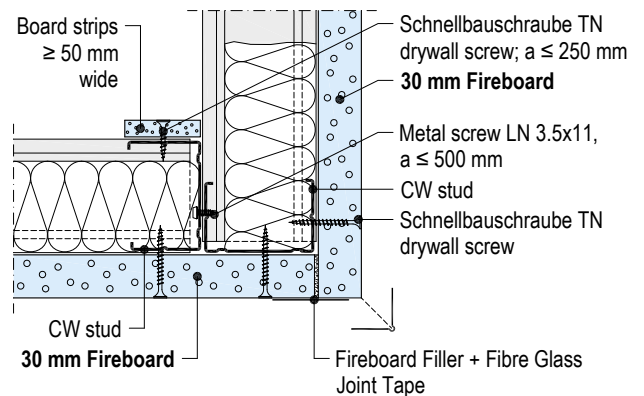

With wall height > 3.00 m

plus Extension of the fire resistance Certificate of Usability
Prior consultation in acc. to page 5 recommended

K251.de-B5 Board joint

Horizontal section

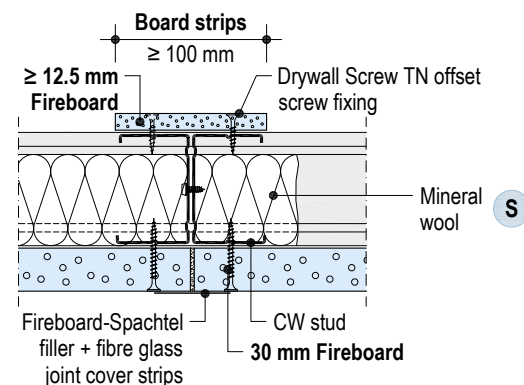

With wall height > 3.00 m

plus Extension of the fire resistance Certificate of Usability
Prior consultation in acc. to page 5 recommended

Note

Installation of an access panel is possible. Application in accordance with the Knauf Access Panel product data sheets.

Details

W635.de-P1 Vertical board layers

2x 15 mm Diamant + intermediate Knauf Piano fire resistant board

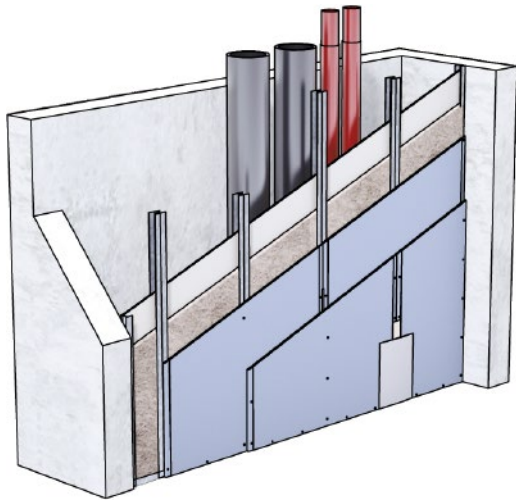

Scale 1:5

W635.de-VO1 Connection to ceiling

Vertical section

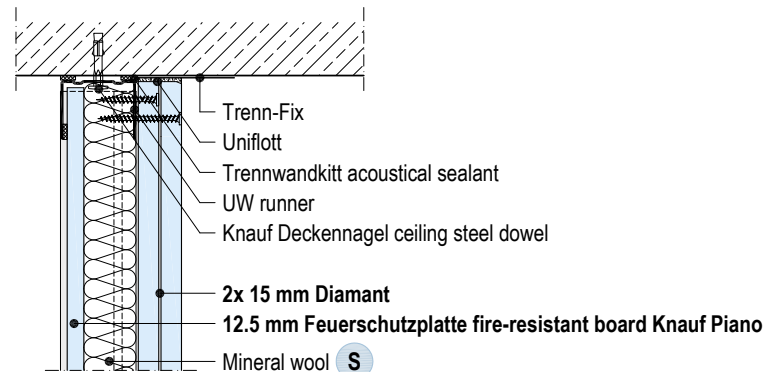

W635.de-VM1 Board joint

Vertical section

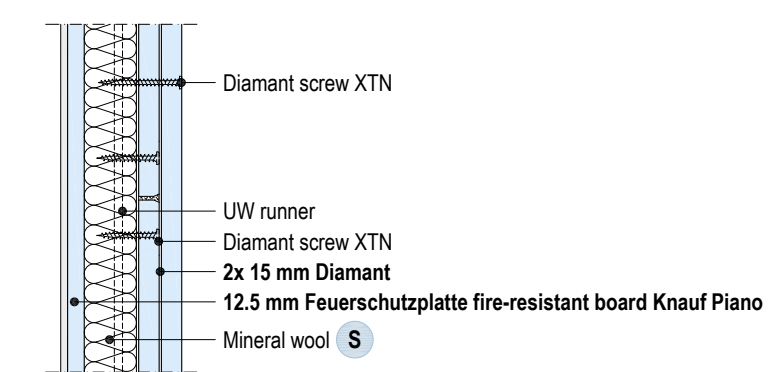

W635.de-VU1 Connection to floor

Vertical section

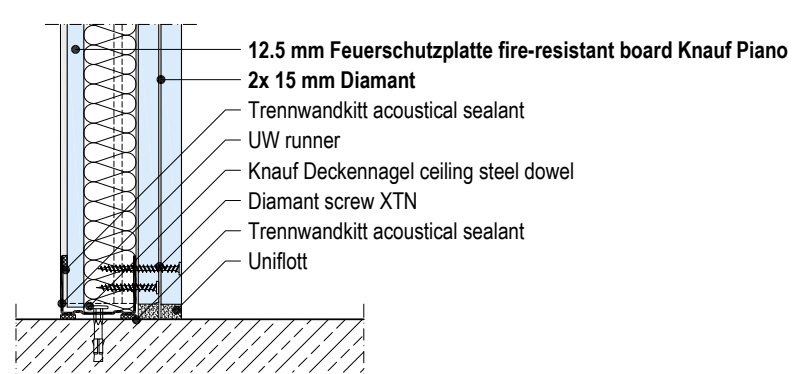

Note Installation of an access panel is possible. Application in accordance with the Knauf Access Panel product data sheets.

Details

W635.de-A1 Connection to solid wall

Horizontal section

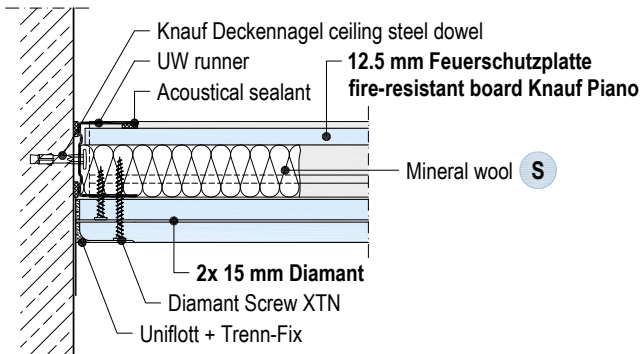

W635.de-B1 Board joint

Horizontal section

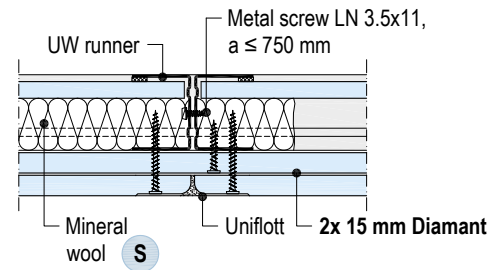

W635.de-D1 Corner

Horizontal section

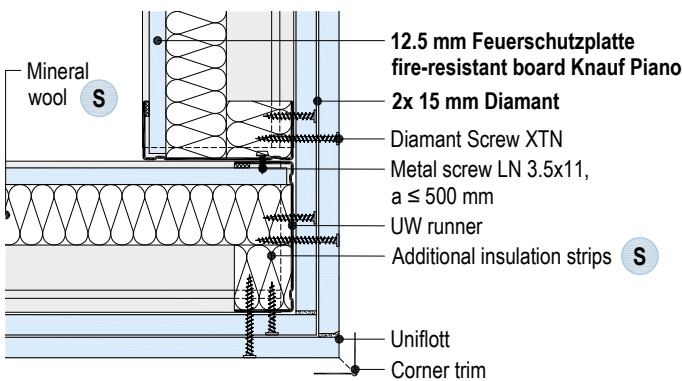

W635.de-D2 Corner

Horizontal section

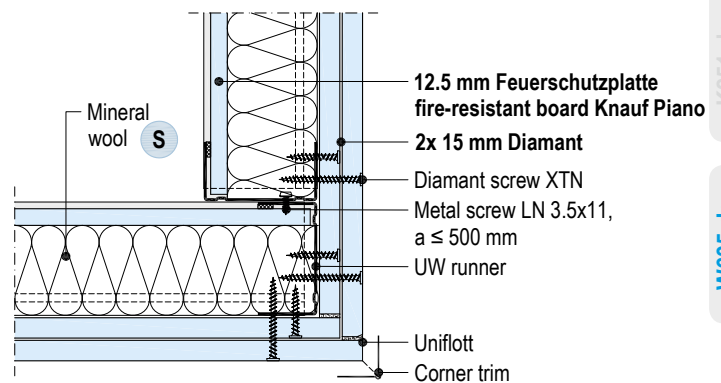

plus Extension of the fire resistance Certificate of Usability
Prior consultation in acc. to page 5 recommended

plus Extension of the fire resistance Certificate of Usability
Prior consultation in acc. to page 5 recommended

Note

Installation of an access panel is possible. Application in accordance with the Knauf Access Panel product data sheets.

W628A.de
W630.de
W628B.de
W629.de
K251.de
W635.de

Detail

W629.de-SO2 Installation shaft

Horizontal section

Scale 1:5

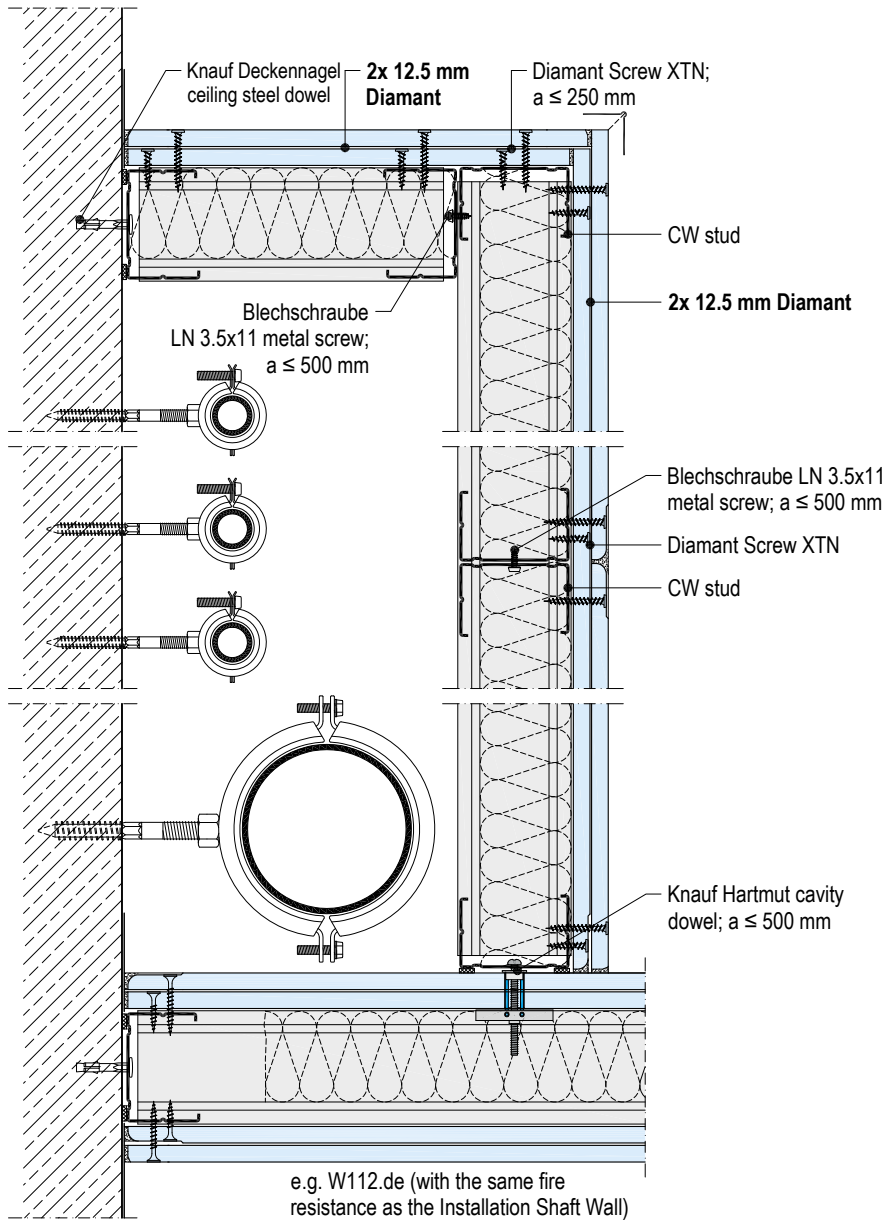

plus Extension of the fire resistance Certificate of Usability
 Prior consultation in acc. to page 5 recommended

Details

W628B.de-SO1 Power sockets with runner frame

Horizontal section

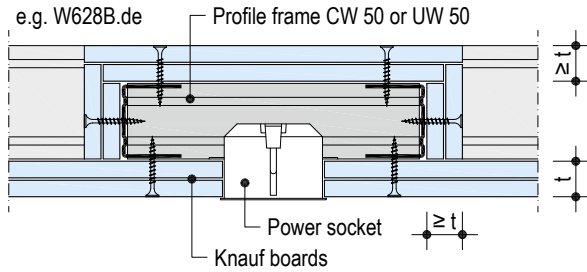

plus Extension of the fire resistance Certificate of Usability
Prior consultation in acc. to page 5 recommended

W628B.de-SO2 Power sockets with runner frame

Vertical section

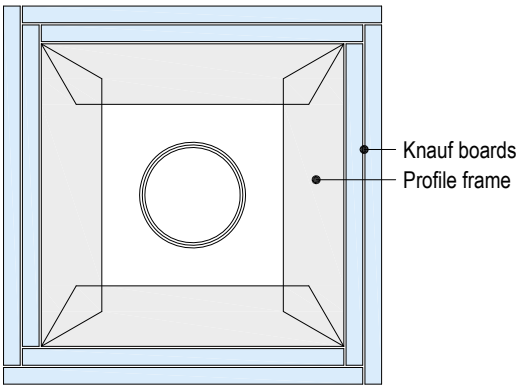

plus Extension of the fire resistance Certificate of Usability
Prior consultation in acc. to page 5 recommended

W629.de-SO6 Power sockets with board backing

Horizontal section

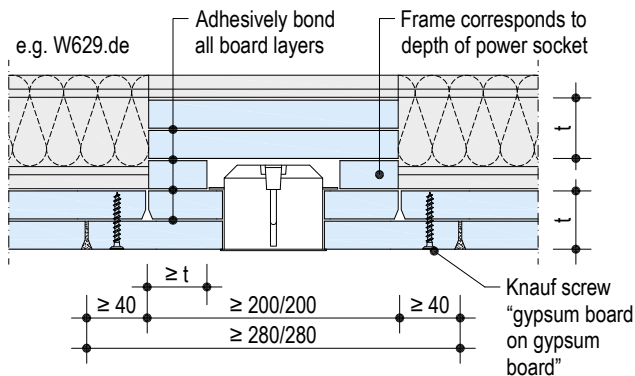

plus Extension of the fire resistance Certificate of Usability
Prior consultation in acc. to page 5 recommended

Note The power sockets must be encased in at least cladding thickness *t* by Knauf GKF/Fireboard boards.

Dimensions in mm | Scale 1:5

W629.de-VO3 Connection to ceiling - deflection head

Vertical section

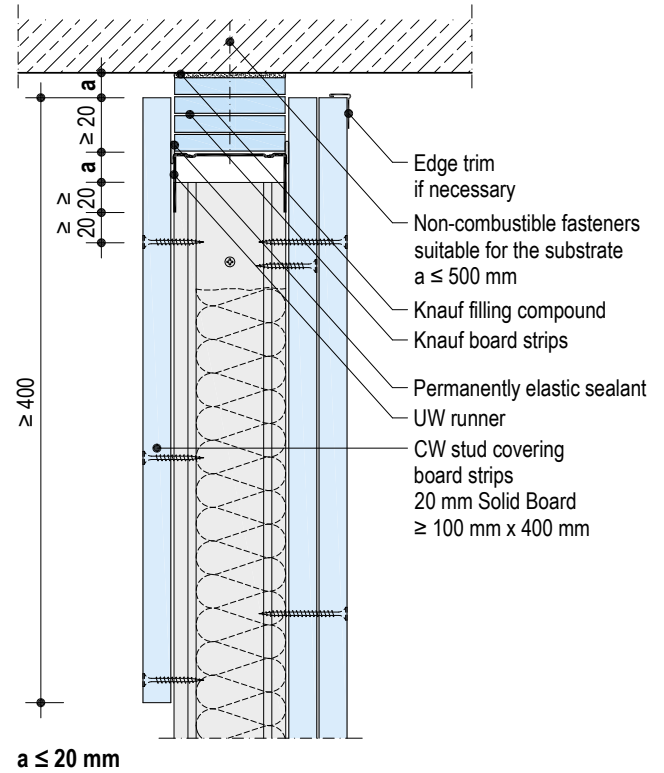

plus Extension of the fire resistance Certificate of Usability
Prior consultation in acc. to page 5 recommended

W628A.de
W630.de
W628B.de
W629.de
K251.de
W635.de

Details

Scale 1:5

W628B.de-SO6 Connection to ceiling on board ceiling

Vertical section

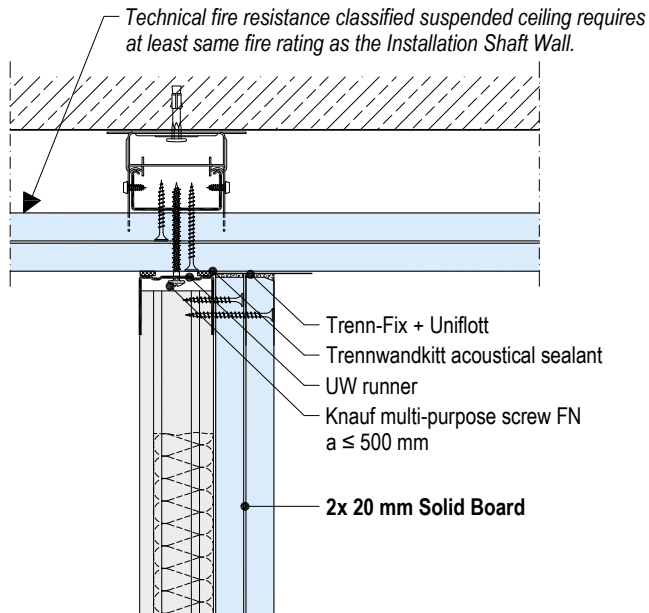

plus Extension of the fire resistance Certificate of Usability
Prior consultation in acc. to page 5 recommended.

W629.de-S10 Connection to ceiling on board ceiling

Vertical section

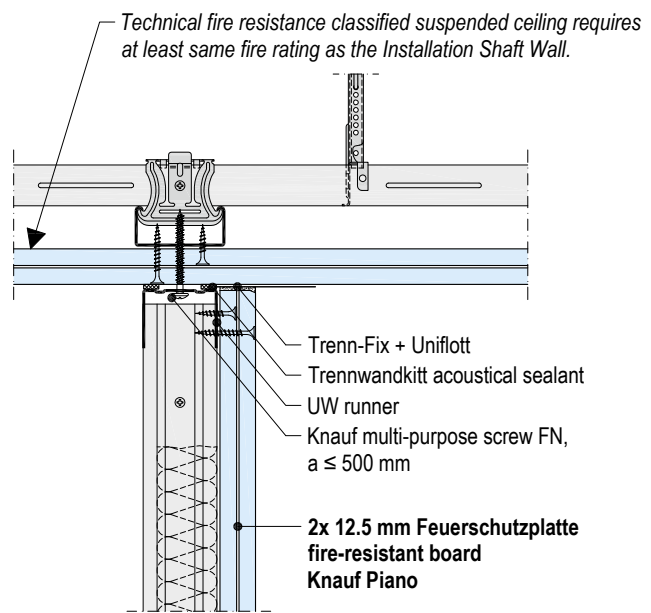

plus Extension of the fire resistance Certificate of Usability
Prior consultation in acc. to page 5 recommended.

W628B.de-SO7 Connection to ceiling to free-spanning ceiling

Vertical section

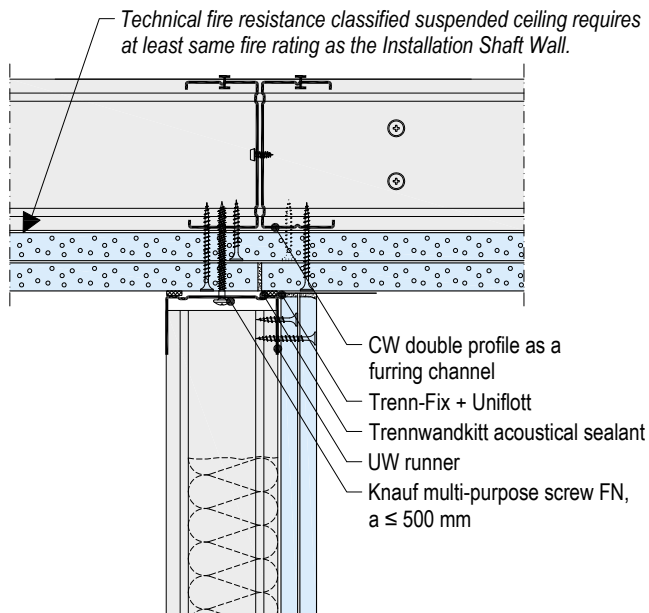

plus Extension of the fire resistance Certificate of Usability
Prior consultation in acc. to page 5 recommended.

W629.de-SO11 Connection to ceiling to free-spanning ceiling

Vertical section

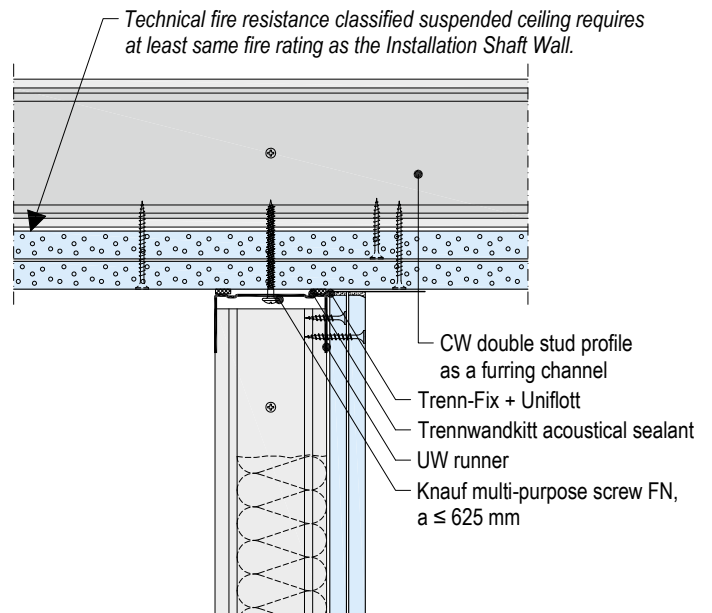

plus Extension of the fire resistance Certificate of Usability
Prior consultation in acc. to page 5 recommended.

Note

Refer to the System Data Sheets for suspended ceiling application

- Knauf Board Ceiling D11.de.
- Knauf Free-Spanning Ceilings D13.de

Details

W629.de-SO7 Connection to steel beam encasement

Vertical section

Technical fire resistance classified beam encasement, at least same fire rating as the Installation Shaft Wall. Minimum thickness of the cladding per side half cladding thickness of Installation Shaft Wall ($t_1 + t_1 \geq t$).

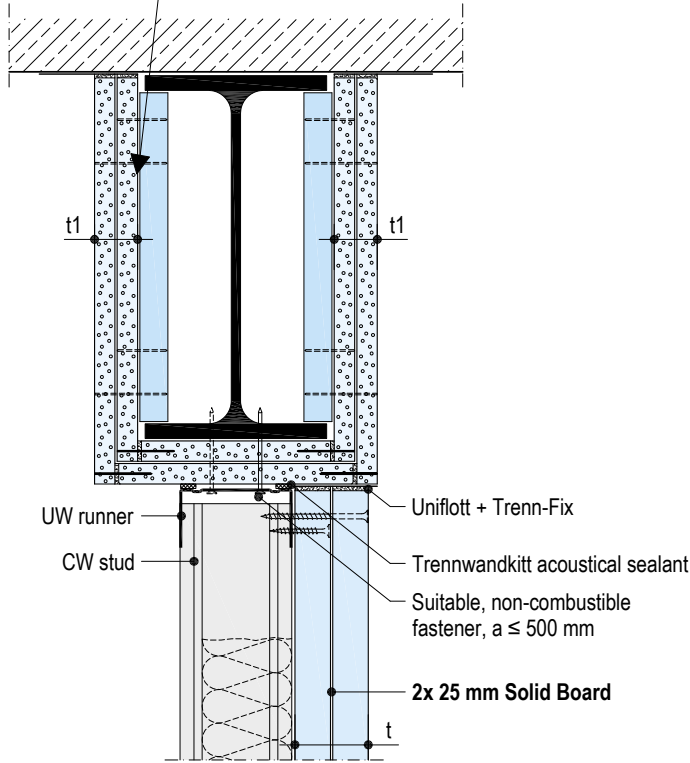

plus Extension of the fire resistance Certificate of Usability
Prior consultation in acc. to page 5 recommended

W628B.de-SO5 Connection to steel column encasement

Horizontal section

Technical fire resistance classified column encasement, requires at least same fire rating as the Installation Shaft Wall. Minimum thickness of the cladding per side half cladding thickness of Installation Shaft Wall ($t_1 + t_1 \geq t$).

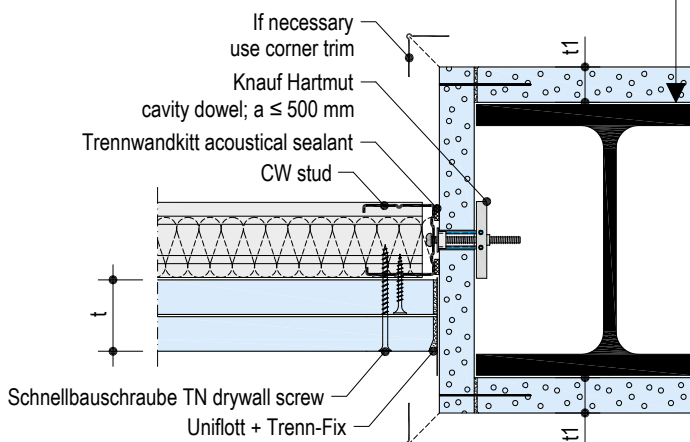

plus Extension of the fire resistance Certificate of Usability
Prior consultation in acc. to page 5 recommended

W629.de-SO8 Connection to steel beam encasement

Vertical section

Technical fire resistance classified beam encasement, at least same fire rating as the Installation Shaft Wall. Minimum thickness of the cladding per side half cladding thickness of Installation Shaft Wall ($t_1 + t_1 \geq t$).

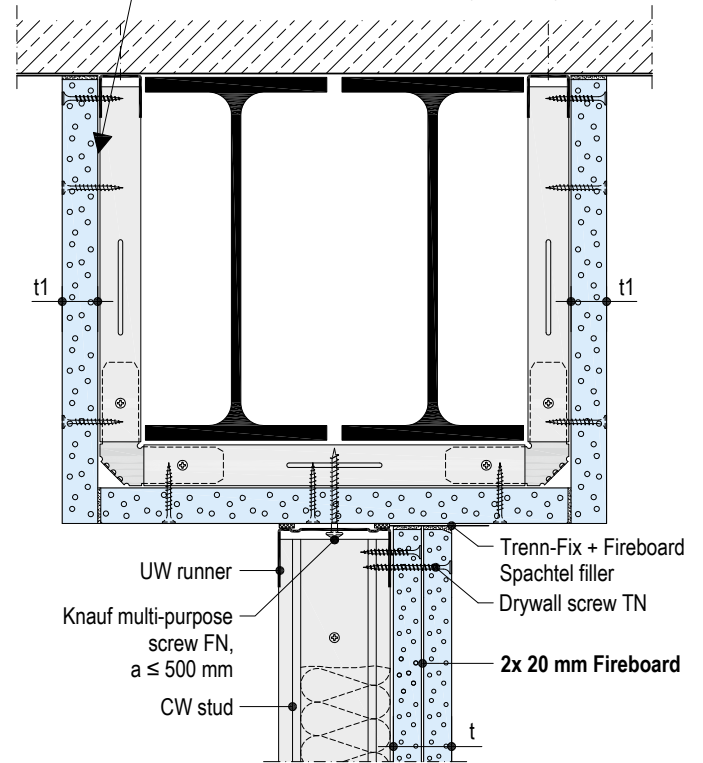

plus Extension of the fire resistance Certificate of Usability
Prior consultation in acc. to page 5 recommended

W629.de-SO9 Connection to steel column encasement

Horizontal section

Technical fire resistance classified column encasement, requires at least same fire rating as the Installation Shaft Wall. Minimum thickness of the cladding per side half cladding thickness of Installation Shaft Wall ($t_1 + t_1 \geq t$).

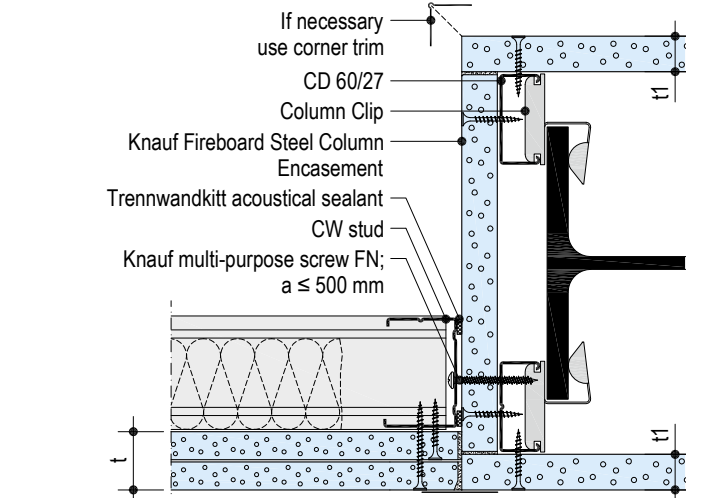

plus Extension of the fire resistance Certificate of Usability
Prior consultation in acc. to page 5 recommended

Details

W628B.de-SO8 Corner – Connection to metal stud partition

Horizontal section

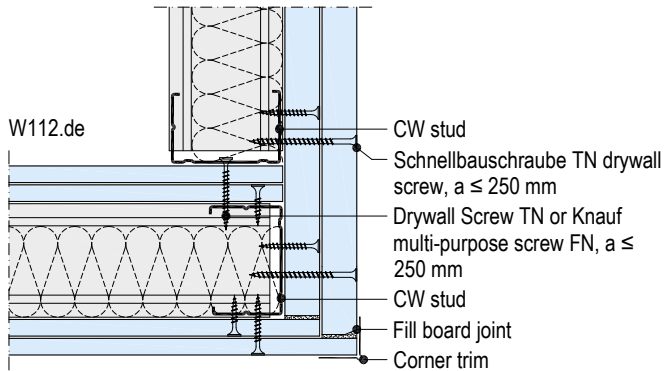

plus Extension of the fire resistance Certificate of Usability
Prior consultation in acc. to page 5 recommended

W629.de-SO12 T connection Installation Shaft Wall

Horizontal section

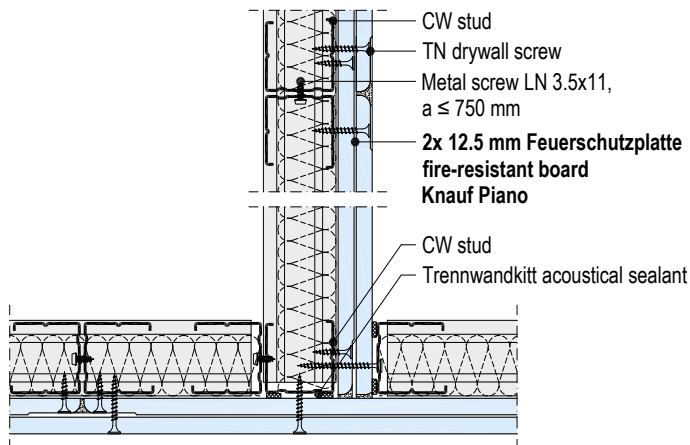

plus Extension of the fire resistance Certificate of Usability
Prior consultation in acc. to page 5 recommended

Dimensions in mm | Scale 1:5

W629.de-SO13 Connection to floor – undercut plinth

Vertical section

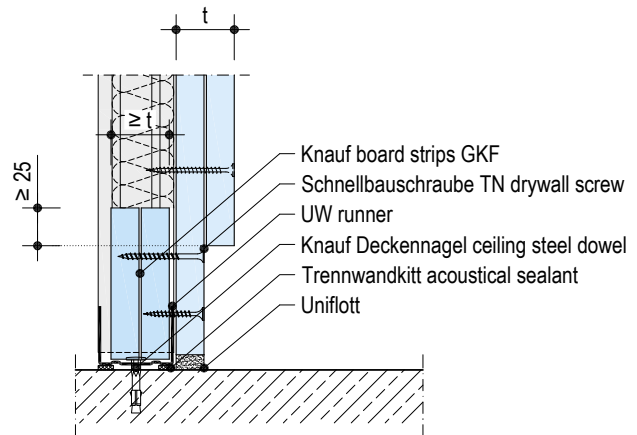

plus Extension of the fire resistance Certificate of Usability
Prior consultation in acc. to page 5 recommended

W628B.de-SO9 Movement joint

Horizontal section

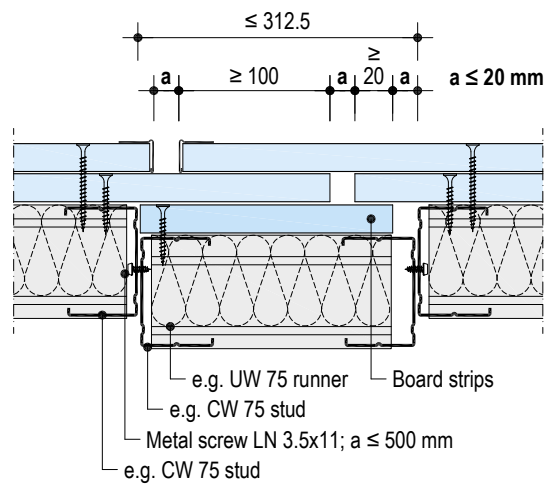

plus Extension of the fire resistance Certificate of Usability
Prior consultation in acc. to page 5 recommended

Upgrading of installation shaft walls with Fireboard



To be observed when upgrading:

- Existing Installation Shaft Wall
 - In accordance with the requirements of the DIN 4103-1
 - Fastening of the UW perimeter runner with non-combustible fasteners suitable for the substrate; $a \leq 625$ mm
 - Maximum spacings of stud profiles / crossbar; $a \leq 625$ mm

Horizontal section | Example

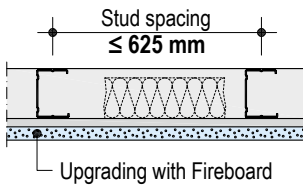

Fastening of the additional cladding made of Fireboard by screw fixing to the profile (alternative fastening on request)

Existing construction

→ **Upgrade** (required cladding, minimum thickness)

Existing Installation Shaft Wall	To F30 Fireboard	To F90 Fireboard
Cladding mm	mm	mm
≥ 12.5 GKB	1x 20	2x 20
$\geq 2 \times 12.5$ GKB	1x 12.5	1x 12.5 + 1x 20 or 1x 30
≥ 12.5 GKF	1x 12.5	1x 12.5 + 1x 20 or 1x 30
$\geq 2 \times 12.5$ GKF	1x 12.5	1x 12.5 + 1x 20 or 1x 30



Extension of the fire resistance Certificate of Usability

- For fire protection reasons on the basis of the expert survey GS 3.2/16-266-1
- Prior consultation in acc. to page 5 is recommended.

W628A.de
W630.de
W628B.de
W629.de
K251.de
W635.de

Lead-through for individual electrical cables

Basics

In accordance with paragraph 40 of the MBO (Model building code), "pipes passing through space-enclosing components for which a fire resistance duration is specified, may only be passed through if the spread of fire need not be feared for a sufficiently long time".

Application options without any particular fire protection measure in acc. to Model Conduit Systems Directive (German designation MLAR), section 4.3.2 for individual cables **a - b - c** (see below) should be taken from the solution examples on this page.

When leading through bundled electrical cables, approved bulkhead systems are required for non-flammable conduits > 160 mm or flammable conduits > 32 mm.

Drywalling approved bulkheads can only be conditionally used in installation shaft walls. The prerequisite is that the installation shaft wall is compliant with the stipulations of the abP/abZ (National Technical Test Certificate/Approval) in the area where the cable lead-throughs are located. This shaft wall section should feature the stability of one of the partition walls. An application option for this feature can be found on "Lead-through for several electrical cables" on page 39.

For applying the cable lead-through's as shown on page 38 and 39, the specifications and notes in Knauf "Brandschutz mit Knauf" (BS1) section "Lead-through for individual electrical cables" or "Lead-through for several electrical cables" in the section "Knauf cable and pipe penetrations" must be observed (German only).

Minimum thickness D

- Fire resistant walls (fh) D ≥ 60 mm
- Highly fire resistant walls (hfh) D ≥ 70 mm
- Fire proof walls (fb) D ≥ 80 mm

Cable type acc. to Model Conduit Systems Directive (German designation MLAR)

- a** Individual electrical cables
- b** Conduits of non-flammable (nbr) building materials ≤ 160 mm
- c** Conduits of flammable (br) building materials ≤ 32 mm

Horizontal sections

Lead through of single electrical cables

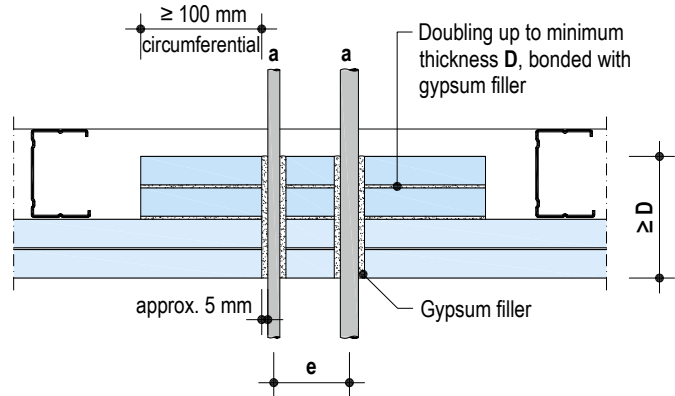

Lead through of non-insulated / insulated single cables

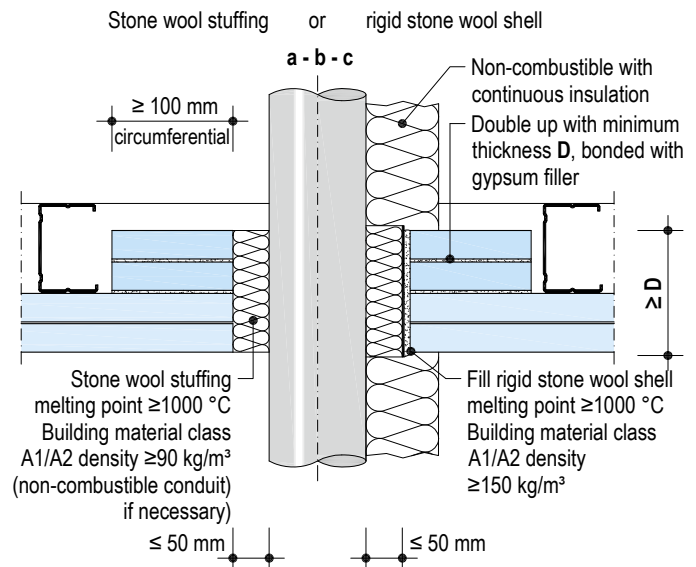

Lead through of non-insulated single cables

Non-combustible conduit with foam-forming material in case of fire (approval required)

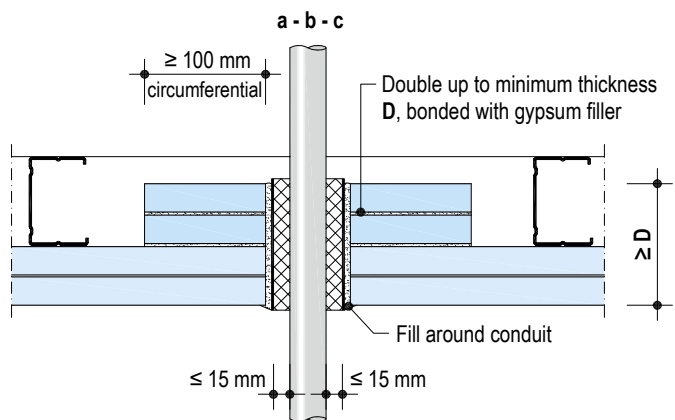

Note

For technically correct implementation, the minimum cable spacings **e** must be observed. Detailed specifications for applying the indicated solution examples as well as further solutions can be found at Knauf "Brandschutz mit Knauf" (BS1) section "Lead-through for individual electrical cables" or "Lead-through for several electrical cables" in the section "Knauf cable and pipe penetrations" (German only).

W628A.de
W630.de
W628B.de
W629.de
K251.de
W635.de

plus Lead-through for several electrical cables

Bulkhead systems - partial upgrading of the shaft side

In order to apply approved bulkhead systems in Knauf Installation Shaft Walls, a partial upgrade to a light partition with double sided cladding, and a component thickness of ≥ 100 mm, is necessary.

The width of at least one section and a height $H =$ bulkhead height + 2×100 mm ($H \geq 500$ mm) is required on the installation shaft wall.

The thickness of the Knauf board GKF to be applied to the shaft side must be ≥ 20 mm. The constructional component thickness in the upgrade area must be ≥ 100 mm.

Required brace in upgraded installation shaft walls

- Installation when assembling the installation shaft wall
 - After upgrading the installation shaft wall to accept the installation of the respective bulkhead system, the brace and reveal cladding must be applied as shown in the drawing opposite.
- Reveal aperture
 - Cladding with Knauf boards minimum in the cladding thickness of the installation shaft wall unless the abZ/abP on the individual bulkheads specifies otherwise
 - Screw centres ≤ 150 mm
 - Apply board width in the reveal area acc. to abZ / abP but at least to min. partition thickness
 - Fill the joints with a gypsum filler
 - Install the bulkhead systems acc. to abZ / abP of the bulkhead manufacturer

Fire protection F30 to F90

Required fire protection cladding / mineral wool acc. to the respective systems.

Horizontal section

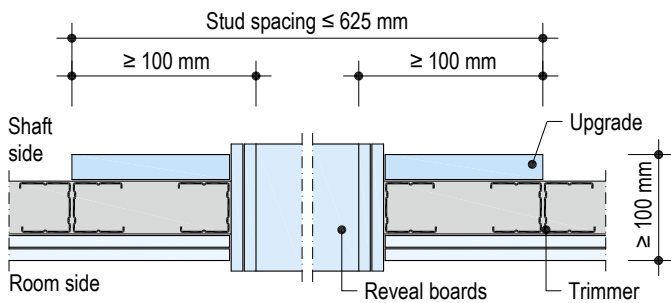

Note Consultation with the bulkhead manufacturer required.

Shaft side view

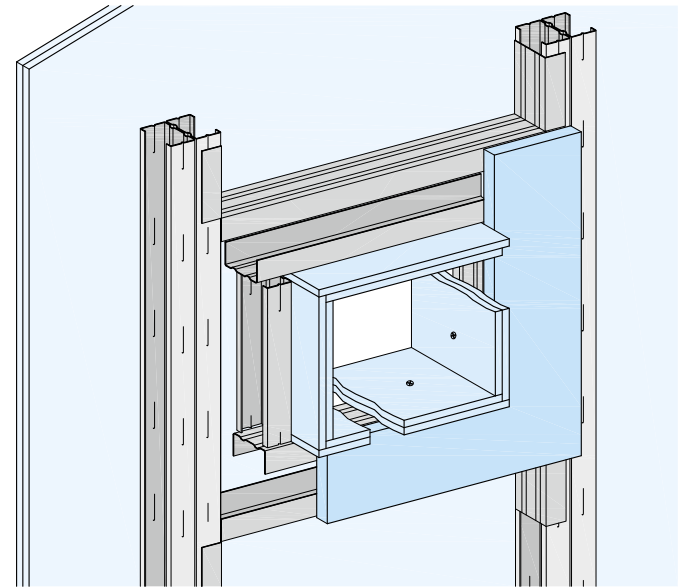

Vertical section

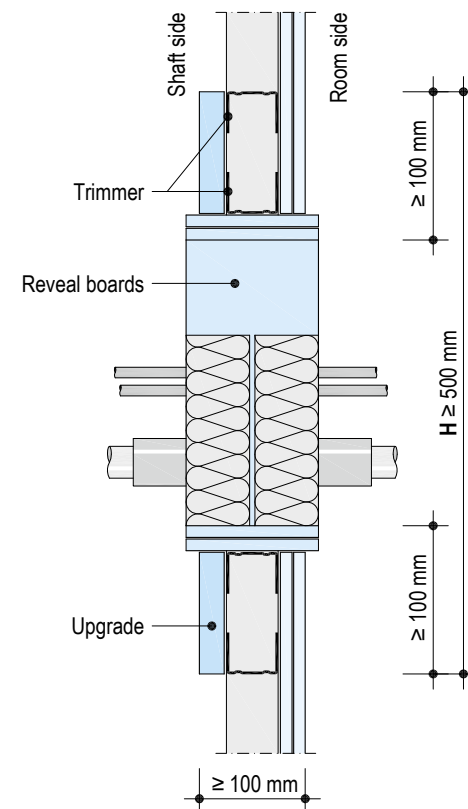

Note

Detailed specifications for applying the indicated solution examples as well as further solutions can be found at Knauf "Brandschutz mit Knauf" (BS1) section "Lead-through for individual electrical cables" or "Lead-through for several electrical cables" in the section "Knauf cable and pipe penetrations" (German only).

plus Extension of the fire resistance Certificate of Usability

- Due to partial upgrading of installation shaft walls Prior consultation in acc. to page 5 is recommended.

W628A.de

W630.de

W628B.de

W629.de

K251.de

W635.de

Stud frame

General

Apply Trennwandkitt acoustical sealant (two strings) or sealing tape to rear side of runners for the connection of flanking constructional components. In case of sound insulation requirements, seal carefully with Trennwandkitt acoustical sealant according to DIN 4109, supplement 1, chapter 5.2; porous sealant strips such as sealing tape are usually not suitable in this case. Fix perimeter runners to the floor and ceiling. Anchor wall perimeter runners with suitable dowels to flanking walls.

Use suitable fasteners:

- Knauf Deckennagel ceiling steel dowel (reinforced concrete without board strip backing)
- Fasteners for the building materials that are specially suitable and non-combustible

Partition height m	Max. fastening spacing Wall perimeter runner mm	Ceiling and floor connection profiles mm
W628A.de		
Up to 15.00	500	—
W630.de		
≤ 3.00	625	625 ²⁾
> 3.00 to 15.00	500	625 ²⁾
W628B.de		
Up to 7.00	500 ¹⁾	500
W629.de		
Up to 7.00	500 ¹⁾	500
K251.de		
Up to 5.00	1000 ²⁾	1000
W635.de		
Up to 5.00	1000 ²⁾	1000

- 1) With wall height > 3.00 m backing of the CW perimeter connection profile on the web side required.
Contact surfaces of the board strips with flanking component provided with acoustical sealant (2 beads).

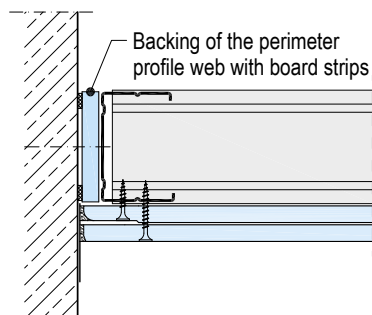

- 2) Structural connection, at least 3 anchoring point per connection

Note Alternative fastening possible using nails. Construction on request.

W630.de Installation Shaft Wall stud crossbars with CW profiles

CW studs, as metal crossbars with spacings of 312.5 mm / double CW studs as crossbars with spacings of 625 mm (625 mm with 2x 12.5 mm cladding not permissible installation shaft width and wall height see page 11); rivet, crimp or apply with screws to UW wall connection profiles. CW crossbar profiles may not be joined or extended.

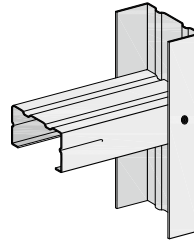

- CW profile as crossbar



Stud crimper for crimp connection

- CW double profile as crossbar

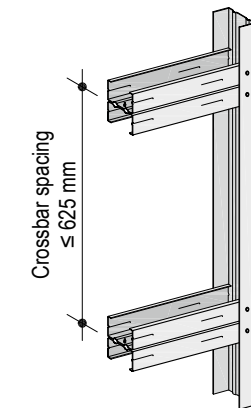
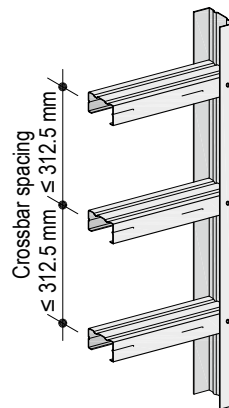

CW double profile preferred variant with installation of insulation layer

W628B.de Installation Shaft Wall – Stud construction with CW profiles

Apply and align CW Studs as stud frame profiles in the perimeter connection profiles at appropriate spacings. With wall heights > 5.00 m fix CW studs to UW runners on ceiling and floor at the shaft side with rivets, crimps or screws.

W629.de Installation Shaft Wall – Stud construction with CW double profiles

Screw two CW profiles to one another on the web side at centres ≤ 500 mm using Metal Screws LN 3.5x11. Apply and align stud frame profiles in the perimeter connection profiles at appropriate spacings. With wall heights > 5.00 m fix double CW studs to UW runners on ceiling and floor at the shaft side with rivets, crimps or screws.

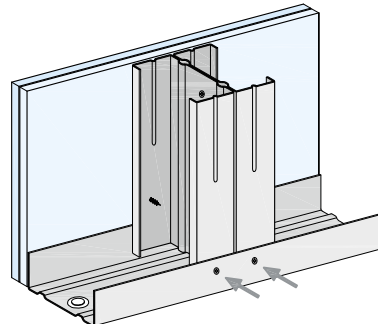

Note The permissible wall heights vary depending on the system variant. Please observe the table in section “Data for planning” on pages 8 to 19.

K251.de – Fireboard Installation Shaft Wall – Stud construction with CW double profiles

Screw two CW profiles to one another on the web side at centres ≤ 500 mm using Metal Screws LN 3.5x11. With wall heights > 3.00 m on the shaft side, screw fix alternating 12.5 mm Fireboard covering strips of width ≥ 100 mm and on the wall perimeter runner of width ≥ 50 mm at a spacing of ≤ 250 mm. Apply and align stud frame profiles in the perimeter connection profiles at appropriate spacings.

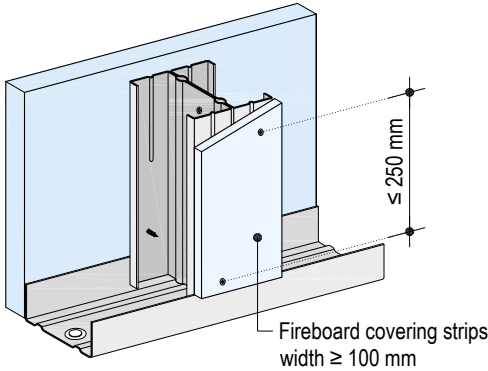

W635.de Installation Shaft Wall – Stud construction with UW double profiles

Screw two UW profiles to one another on the web side at centres ≤ 750 mm using Metal Screws LN 3.5x11. Apply and align stud frame profiles in the perimeter connection profiles at appropriate spacings.

Apply Acoustical Sealant to the inner surface of the shaft sided flange of the double UW runner and apply and push on a 12.5 mm layer of Knauf Piano fire resistant board.

Vertical profile extensions

Dimensions in mm

Alternative 1

2 CW profiles connected to form a box.

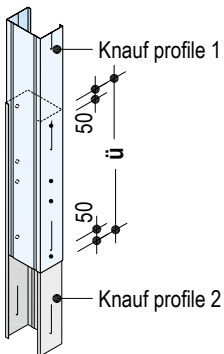

Alternative 2

2 CW profiles butt jointed, connected with additional UW runner.

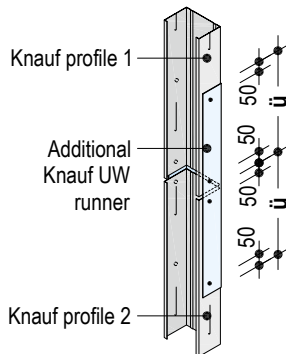

Profile extensions	
Knauf profiles	Overlap ü
CW 50	≥ 500 mm
CW 75	≥ 750 mm
CW 100	≥ 1000 mm

- Stagger the heights of the profile joints (alternating upper and lower wall half).
- Crimp, screw fix or, if possible, crimp the profiles in the overlapping area.

Insulation layer

General

Depending on the requirements for fire protection, sound insulation and thermal insulation, secure the insulation against sliding (compress up to approx. 10 mm) and tightly joint in the grid (or if necessary install insulation strips as to prevent sliding in the stud profiles).

Additional insulation strips for deviation of the insulation material thickness > 20 mm from the stud web width.

W629.de Installation Shaft Wall – Stud construction with CW double profiles

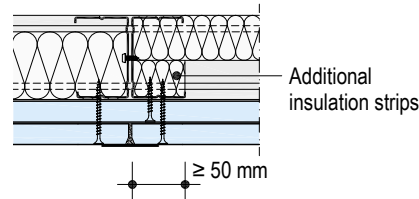

K251.de Fireboard Installation Shaft Wall – Stud construction with CW double profiles

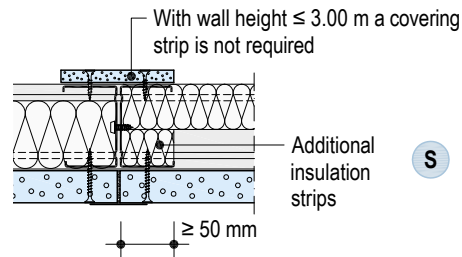

W635.de Installation Shaft Wall – Stud construction with UW double profiles

Fill the UW 75 / UW 100 runners completely with additional insulation **S**

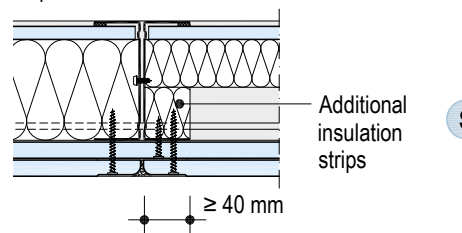

Installation schemes

W630.de Horizontal board layers

- Feuerschutzplatte Knauf Piano fire resistant board / Diamant (board width 1250 mm)
- Crossbar spacing 312.5 mm

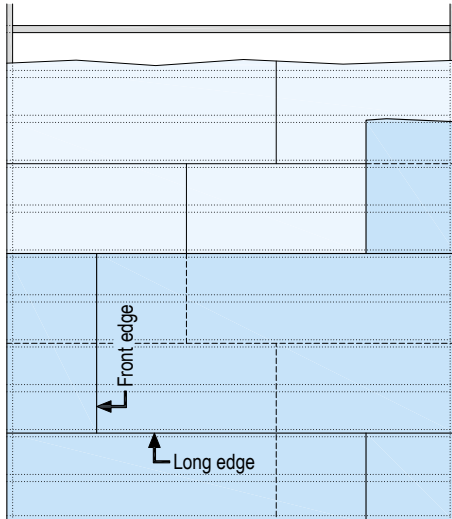

Lower/upper layer:

- Offset front edge joint by at least 500 mm.
- Arrange the long edge joints on the crossbar.

Offset between lower and upper layer:

- Stagger long edge joints by 625 mm.
- Stagger the front edge joints between board layers.

W630.de Board layer 1 horizontal, board layer 2 vertical

- 2x 20 mm Massivbauplatte Solid Board (board width 625 mm)
- Crossbar spacing 312.5 mm

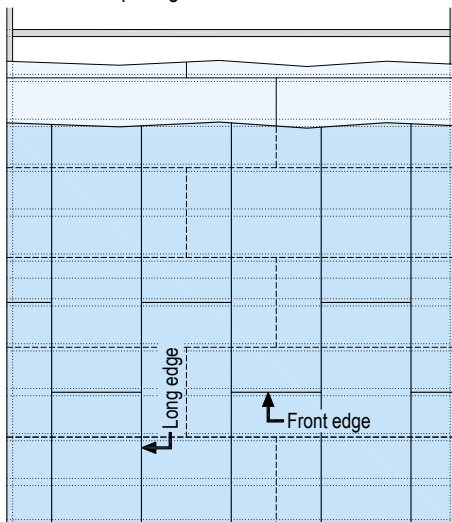

Lower layer:

- Offset front edge joint by at least 500 mm.
- Arrange the long edge joints on the crossbar.

Upper layer:

- Arrange the front edge joints on the crossbar and stagger by 625 mm.

Offset between lower and upper layer:

- Stagger the board joints of the upper layer by approx 312.5 mm to the board joints of the lower layer.

Scheme drawings | Dimensions in mm

W628B.de/W629.de Horizontal board layers

- Silentboard / Massivbauplatte Solid Board (board width 625 mm)
- Stud spacing 625 mm

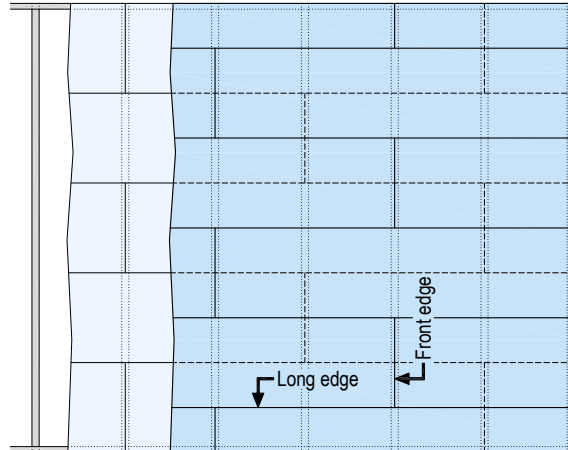

Lower/upper layer:

- Recommendation: Board length 2500 mm
- Front edge joints must be staggered by at least one stud spacing.
- Stagger the long joints between the cladding layers by at least half a board width.

W628B.de/W629.de/K251.de/W635.de Vertical board layers

- Feuerschutzplatte Knauf Piano Fire Resistant Board / Diamant / Knauf Feuerschutzplatte Fire Resistant Board / Fireboard (board width 1250 mm)
- Stud spacing 625 mm

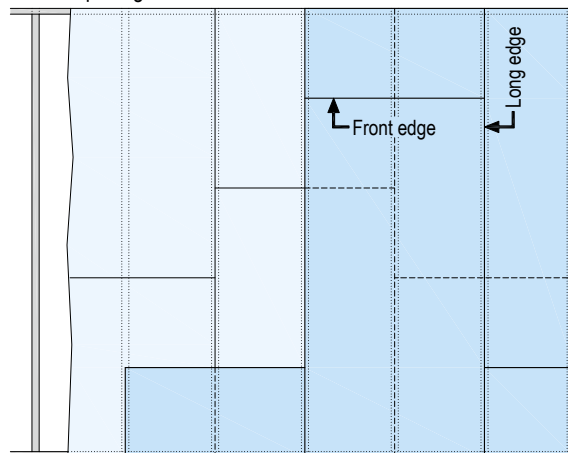

Lower/upper layer:

- Stagger long edge joints by 625 mm (one stud spacing)
- If non floor-to-ceiling high boards are used, stagger the front edge joints ≥ 500 mm (for K251.de ≥ 1000 mm) in a cladding layer.
- For K251.de apply backing to front joints using profiles or Fireboard strips.
- Stagger the front edge joints between board layers in case of multi-level cladding.

Fastening of the cladding to the stud frame with Knauf drywall screws

Cladding		Metal stud frame (Penetration ≥ 10 mm) Metal gauge s ≤ 0.7 mm		Maximum spacings	
Board type	Minimum thickness mm	Drywall screws		Fastener	
		TN	Diamant screws XTN	1st layer mm	2nd layer mm
W628A.de					
Massivbauplatte Solid Board	2x 25	TN 3.5 x 35 + TN 4.5 x 70	–	300	200
W630.de					
Feuerschutzplatte Knauf Piano Fire Resistant Board	2x 12.5	TN 3.5 x 25 + TN 3.5 x 35	–	750	250
Diamant	2x 12.5	–	XTN 3.9 x 23 + XTN 3.9 x 38	750	250
Massivbauplatte Solid Board	2x 20	TN 3.5 x 35 + TN 3.5 x 55	–	600	200
W628B.de / W629.de					
Feuerschutzplatte Knauf Piano Fire Resistant Board	2x 12.5	TN 3.5 x 25 + TN 3.5 x 35	–	750	250
Diamant	2x 12.5	–	XTN 3.9 x 23 + XTN 3.9 x 38	750	250
Silentboard	2x 12.5	–	XTN 3.9 x 23 + XTN 3.9 x 38	600	200
Knauf Feuerschutzplatte Fire Re- sistant Board	2x 15	TN 3.5 x 25 + TN 3.5 x 45	–	750	250
Diamant	2x 15	–	XTN 3.9 x 33 + XTN 3.9 x 55	750	250
Massivbauplatte Solid Board (W629.de only)	2x 20	TN 3.5 x 35 + TN 3.5 x 55	–	600	200
Fireboard	2x 20	TN 3.5 x 35 + TN 3.5 x 55	–	750	250
Massivbauplatte Solid Board	2x 25	TN 3.5 x 35 + TN 4.5 x 70	–	300	200
K251.de					
Fireboard covering strips	12.5	TN 3.5 x 25	–	250	–
Fireboard	30	TN 3.5 x 45	–	250	–
W635.de					
Diamant	2x 15	–	XTN 3.9 x 33 + XTN 3.9 x 55	750	250

Note

Alternative fastening possible using nails. Construction on request.

Jointing

Jointing of the boards in the required quality level Q1 to Q4 in accordance with Code of Practice no. 2 "Verspachtelung von Gipsplatten, Oberflächengüten"¹⁾.

Fill in visible screw heads.

With Fireboard, a skim coating of the entire surface, e.g. with Fireboard Filler is additionally required before application of direct coatings or linings.

Suitable jointing materials

- Uniflott
Hand filling without joint tape strips in the long joint edges
- Uniflott imprägniert
Hand filling of impregnated boards without joint tape in the long joint edges; water-repellent, green colour for easy identification
- Fugenfüller Leicht
Hand filling with joint tape, preferably Fugendeckstreifen Kurt joint tape
- Fireboard Filler
Hand filling of Fireboard with Fibre Glass joint tape

Suitable finish jointing compounds

- Q2, application by hand
Uniflott, Uniflott imprägniert, Fill & Finish, SuperFinish
- Q3/Q4, application by hand
Readygips, SuperFinish, Fill & Finish
- Q3/Q4, machine application:
ProSpray Light (preferably Q3), Readygips
- Fireboard-Spachtel filler for full surface skimming of Fireboard

Filling of the gypsum board joints

For multi-layer cladding, fill the lower layers with filler; fill the joints of the visible layer. Filling the joints of covered cladding layers with multi-layer cladding is necessary to provide technical fire protection and sound

insulation properties as well as the structural properties!

Recommendation

Front edge and cut edge joints as well as mixed joints (e.g. HRAK + cut edge) of the visible cladding layers filled using Uniflott with Kurt joint tape as well.

Jointing of connection joints

Apply Trenn-Fix or Kurt joint tape when filling joints to adjacent drywall constructions, depending on the conditions and requirements for crack safety.

Observe code of practice no. 3 "Gipsplattenkonstruktionen - Fugen und Anschlüsse"¹⁾ (German only)

Apply Trenn-Fix when filling joints to adjacent solid construction or timber components.

Sanding

Lightly sand visible surfaces after drying of the filler material, if required.

Application temperature/climate

Filling and covering of joints should only take place when no more longitudinal changes can be expected, i.e. expansion or contraction due to humidity or temperature changes.

Do not apply jointing at room or substrate temperatures below approx. +10 °C.

In case of mastic asphalt screed, cementitious screed and self-levelling screed, fill in board joints after screed has been applied.

Observe code of practice no. 1 "Baustellenbedingungen"¹⁾.

1) (German only), issued by the Bundesverband der Gipsindustrie e.V.

Quality levels	Jointing Long edge HRAK or HRK	Jointing Front edge SFK	Description working steps.
Q1			<ul style="list-style-type: none"> ■ Fill the joints with Uniflott or Uniflott imprägniert ■ Fill all visible fastener parts.
Q2			<ul style="list-style-type: none"> ■ Preliminary jointing in acc. with quality level Q1 ■ Finish (finish compound) until a smooth transition to the board surface is achieved using e.g. Uniflott, Uniflott imprägniert, Readygips, Fill & Finish or SuperFinish <p>No application marks or ridges may remain visible. Sand off the areas concerned if necessary.</p>
Q3			<ul style="list-style-type: none"> ■ Jointing in acc. with quality level Q2 ■ Wide jointing of the joints as well as clean and accurate removal of the remaining board liner filling the pores, e.g. with Readygips, SuperFinish, Fill & Finish or ProSpray Light. <p>If necessary, i.e. physical ridges and grooves are not acceptable and must be sanded.</p>
Q4			<ul style="list-style-type: none"> ■ Jointing in acc. with quality level Q2 ■ Complete surface covering of skim coat with a layer thickness of at least 1 mm, e.g. with Readygips, Fill & Finish or SuperFinish

Coatings and linings

Coating / lining	Recommended jointing	
	Gypsum boards EN 520 ¹⁾	Fireboard
Tiles or similar	Q1	Jointing
Linings with coarse textures (e.g. wood chip wallpaper)	Q2	Full surface skimming
Finely textured wallpapers	Q3/Q4	Full surface skimming
Matt, textured coats	Q3/Q4	Full surface skimming
Glossy, smooth coats	Q4	Full surface skimming
Plasters (grain size < 1 mm)	Q3/Q4	Full surface skimming
Plasters (grain size ≥ 1 mm)	Q2	Jointing

Pretreatment

Before further coating or lining is applied, the filled surface must be free of dust. Always prime gypsum board surfaces in compliance with the Code of Practice no. 6 of "Vorbehandlung von Trockenbauflächen aus Gipsplatten zur weitergehenden Oberflächenbeschichtung bzw. -bekleidung" (German only)¹⁾.

Ensure that the primer is compatible with the coating / paint / lining.

In order to compensate for the differences in absorption of surfaces, coatings of primer such as Tiefengrund primer is suitable.

Where a wallpaper lining is used, a primer that facilitates easier removal of wallpaper for redecoration is recommended.

With lining in bathrooms and areas that require high moisture resistance, sealing may be required - Observe Code of Practice No. 5 "Bäder, Feucht- und Nassräume im Holz- und Trockenbau" ¹⁾ (German only).

Note

Gypsum board surfaces that have constantly been exposed to light without any protection can cause yellowing. Therefore, a trial coat is recommended that will extend across several boards including all joints. Yellowing can, however, be successfully avoided only by using a special primer, e.g. Knauf Aton Sperrgrund for finishing plasters, Knauf Sperrgrund for coatings.

Suitable coatings and linings

The following coatings/linings can be applied to Knauf boards:

- Wallpapers
 - Paper, fleece, textile and synthetic wallpapers
Use only adhesives made of methyl cellulose according to Code of Practice no. 16, "Technische Richtlinien für Tapezier- und Spannarbeiten innen" ²⁾.
- Plaster and filler materials
 - Finishing plasters (e.g. Noblo, Raumklima Spritzputz, Rotkalk Filz)
 - Full surface plaster (e.g. Readygips, ProSpray Light).
Application of plaster layers only in conjunction with Fugendeckstreifen Kurt joint tape.
- Decorative coats

- Dispersion paints (e.g. Intol E.L.F., Malerweiss E.L.F.)
- Silicate-based emulsion paints with suitable primer.
- Others on request
- Ceramic tiles
 - System W628A.de only up to 1.00 m installation shaft width
 - Minimum cladding thickness 18 mm (Diamant: 15 mm), e.g. 2x 12.5 mm with stud pacing 625 mm
 - With narrower cladding thickness, reduce the stud spacing to max. 417 mm.

Unsuitable coatings and linings

- Alkaline coats such as lime-based paints, water glass paints and silicate-based paints.

Notes

After wallpapering or after application of plasters, quick drying must be ensured through adequate airing.

Other coatings or layers and vapour barriers up to about 0.5 mm thickness as well as claddings (with the exception of sheet steel), do not have any influence on the technical fire resistance classification of Knauf Installation Shaft Walls.

- 1) (German only), issued by the Bundesverband der Gipsindustrie e.V.
- 2) (German only), issued by the Bundesausschuss Farbe und Sachwerterschutz

Material requirement per m² of installation shaft wall without allowance for loss and waste.

Description	Unit	Quantity as average value					
		W628A.de F90	W630.de F30	W628B.de F90	W629.de F90	K251.de F90	W635.de F90
Stud frame							
Knauf angle profile 50/35/0.7	m	1	–	–	–	–	–
Knauf UW runner; e.g. UW 50	m	–	0.5	0.7	0.7	0.7	4.3
Knauf CW stud; e.g. CW 50	m	–	3.7	2.0	3.5	3.5	–
Knauf CW stud/UW runner as a joint backing	m	–	–	–	–	0.3	–
Knauf Metal Screw LN 3.5 x 11 (Connection to double stud)	pcs	–	–	–	3.8	3.8	2.8
<i>Metal blind rivet alternative: Metal screw LN 3.5 x 11 or crimped (Connect CW stud to UW runner)</i>	pcs	–	2.9	–	–	–	–
Knauf Trennwandkitt acoustical sealant	pcs	0.2	0.3	0.3	0.3	0.3	0.3
<i>Alternative</i> Knauf Dichtungsband sealing tape; e.g. 50/3.2 mm	m	1.0	1.2	1.2	1.2	1.2	1.2
Knauf Acoustical Sealant for installing intermediate board	pcs	–	–	–	–	–	0.4
With fasteners suitable for the substrate that are compliant with the fire protection requirements							
Knauf Ceiling Steel Dowel with reinforced concrete	pcs	2.2	0.7	0.9	0.9	0.9	0.9
<i>Alternative</i> Fasteners specially for the building materials that are suitably non-combustible	pcs	–	0.9	0.7	0.7	0.7	0.7
Insulation layer, e.g. Knauf Insulation	m ²	as req.	as req.	as req.	as req.	1.0	1.0
Knauf boards							
Feuerschutzplatte Knauf Piano fire resistant board; 12.5 mm	m ²	–	–	–	–	–	1
Diamant 12.5 mm	m ²	–	2	–	–	–	–
Diamant 15 mm	m ²	–	–	–	–	–	2
Massivbauplatte Solid Board 20 mm	m ²	–	–	–	2	–	–
Massivbauplatte Solid Board 25 mm	m ²	2	–	–	–	–	–
Fireboard 12.5 mm (board strips)	m ²	–	–	–	–	as req.	–
Fireboard 20 mm	m ²	–	–	2	–	–	–
Fireboard 30 mm	m ²	–	–	–	–	1	–
Fastening (fastening of the boards, Knauf fasteners see page 43)							
1st layer	pcs	5.5	11	8	10	18	8
2nd layer	pcs	7	22	16	18	–	16
Board strips	pcs	–	–	–	–	as req.	–
Jointing (e.g. quality level Q2) – see also page 44							
Knauf filling compound, e.g. Uniflott	kg	0.8	0.4	–	0.85	–	0.5
Fireboard Filler	kg	–	–	0.6	–	0.55	–
Fugendeckstreifen Kurt joint tape (for front edges)	m	–	as req.	–	as req.	–	as req.
Knauf fibre glass joint tape (long and front edges)	m	–	–	1.1	–	1.1	–
Trenn-Fix, 65 mm wide, self-adhesive	m	as req.	0.9	0.9	0.9	0.9	0.9
Knauf edge/corner trims; e.g. Kantenschutzprofil edge trim 23/13	m	as req.	as req.	as req.	as req.	as req.	as req.

Legend:

as req. = as required

Material not provided by Knauf = printed in italics

The quantity relates to a partition area of:

- W628A.de:
H = 2.75 m; L = 2.00 m; A = 5.50 m²
- W630.de / W628B.de / W629.de / K251.de / W635.de:
H = 2.75 m; L = 4.00 m; A = 11.00 m²

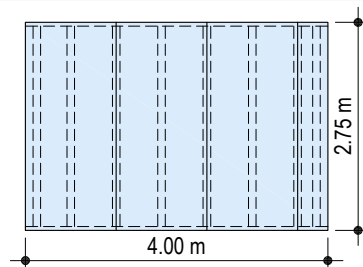

Technical advice

You ask. We answer. Knauf Direkt

Competent advice and information

Our extensive long-standing expertise for your safety and peace of mind – advice “just in time”.

Knauf Direkt is a team of technically competent employees with a wide skill base. Architects, building physicists, master timber construction craftsmen and many other areas assist you with professional advisory services in the areas of timber construction, drywalling, plastering/stucco work and architecture.

Competent building consultancy advice assures the use of efficient systems and avoids the cost of additional materials or overly complex constructions. Furthermore, the assurance you receive often saves multiples of the avoided building damage and compensation claims.

The Knauf Direkt employees can direct you to a Knauf system consultant for on-site consultation on building projects. They offer you support for your building projects including personal consultation on the building site - quickly, competently and free-of-charge.

We know you. It pays off.

We offer listed customers or partners telephone advice at a reduced tariff on a German land line. Furthermore, you are automatically directed to the next free colleague.

How to contact us

The right partner for every technical query.



- For questions on drywalling and floor systems
Tel.: 09001 31-1000¹⁾ (Germany only)
- For questions on plaster and façade systems
Tel.: 09001 31-2000¹⁾ (Germany only)

Availability:

Mo – Th 7:00 – 18:00 and

Fr 7:00 – 17:00

1) A call to Knauf Direkt is charged at € 0.39/min in Germany. Callers whose phone numbers are not registered within the Knauf address data base, e.g. private builders or non-customers, will be charged a rate of € 1.69 per minute within Germany. Calls from mobiles will be charged depending on the tariffs of the network operator.

Tendering centre

Quickly and comfortably create complete tender specifications

Your tender - quick and complete

The comprehensive platform offers more than 3000 up-to-date tendering specification texts in various formats (Word, GAEB, PDF, HTML). The complete texts are arranged systematically and available on an interdisciplinary basis for the areas of drywalling, floor systems and plaster and façade. Comprehensive tender specifications such as a complete external thermal insulation composite system can be put together in minutes.



Up-to-date tender specifications for everyone
Knauf systems and products
www.ausschreibungscenter.de

Access to certificates of usability for fire protection

In the abPs (German National Technical Test Certificate), a fire test performed according to the applicable standards is documented and the scope (possible applications) for the tested system that can be used in practice is described.

Here at

www.knauf.de/profi/tools-services/kontakt/

you can access the available test certificate for your building site.

CAD design details

All of the design details in this System Data Sheet as well as further details can be found at

www.knauf.de/profi/tools-services/dokumenten-center/cad-details-downloaden/

Available for download in the formats DWG, DXF, PDF and GIF.

Information on sustainability of Knauf Installation Shaft Walls

Building assessment systems ensure the sustainable quality of buildings and constructional structures by a detailed assessment of ecological, economic, social, functional and technical aspects.

The following certification systems have a particular relevance in Germany

- DGNB System
Deutsches Gütesiegel Nachhaltiges Bauen der DGNB (German Association for Sustainable Building)
- BNB
(Bewertungssystem Nachhaltiges Bauen)
- LEED
(Leadership in Energy and Environmental Design).

Knauf products and Knauf Installation Shaft Walls can positively influence many of these criteria.

DGNB/BNB

Ecological quality

- Criterion: Risks for the local environment
The relevant environmental data are contained in the EPD for gypsum products

Economic quality

- Criterion: Building related life-cycle costs
Cost-effective Knauf Drywalling

Sociocultural and functional quality

- Criterion: Space efficiency
Slim, floor-space enhancing Knauf Installation Shaft Walls
- Criterion: Suitability for conversion
Flexible Knauf Drywalling

Technical quality

- Criterion: Sound insulation
Exceeding the demands of the standard with Knauf sound protection
- Criteria: Ease of dismantling and recycling
Knauf Drywalling is fully compliant

LEED

Materials and resources

- Credit: Recycled Content
Recycled content in Knauf boards, e.g. FGD gypsum
- Credit: Regional Materials
Short transport routes provided by the extensive network of Knauf manufacturing facilities



The iPad App Knauf Infothek now provides all the current information and documents from Knauf Gips KG at any time and in every location in a clear and comfortable way.

[Knauf Infothek](#)

Knauf Direct

Technical Advisory Service:

▶ knauf-direkt@knauf.de

▶ www.knauf.de

Knauf Gips KG Am Bahnhof 7, 97346 Iphofen, Germany

All technical changes reserved. Only the current printed instructions are valid. The stated information represents current state-of-the-art Knauf technology. The entire state of approved engineering rules, appropriate standards, guidelines, and rules of craftsmanship are not included herewith. These and all application instructions have to be adhered to separately by the installer. Our warranty is expressly limited to our products in flawless condition. All application quantities and delivery amounts are based on empirical data that are not easily transferable to other deviating areas.

All rights reserved. All amendments, reprints and photocopies, including those of excerpts, require our expressed permission.