

Note on English translation / Hinweise zur englischen Fassung

This is a translation of the Technical Information valid in Germany.

All stated details and properties are in compliance with the regulations of the German standards and building regulations. They are only applicable for the specified products, system components, application rules, and construction details in connection with the specifications of the respective certificates and approvals.

Knauf Gips KG denies any liability for applications outside of Germany as this requires changes acc. to the respective national standards and building regulations.



Drywall Systems

VT03.de

Technical Information 2023-02

Fastening of Loads to Knauf Wall and Ceiling Systems

Knauf Traverses

Knauf Surface traverse

Knauf Sanistands

Knauf Boards

Knauf Anchoring



- Knauf Wall gypsum fibre insert 18
- Knauf damp room traverse C3
- Knauf Surface traverse – Diamant Steel

Contents

| | |
|---|----|
| Usage instructions | |
| Notes | 4 |
| Notes on the document | 4 |
| Intended use of Knauf Systems | 4 |
| <hr/> | |
| Loads on partitions and furrings | |
| Introduction | 5 |
| Cantilever loads | 6 |
| Rating tables / diagrams | 6 |
| Anchoring in the cladding | 8 |
| Fields of application | 8 |
| Fixing loads | 9 |
| Rating | 10 |
| Anchoring in the traverses | 11 |
| Fields of application | 11 |
| Fixing loads | 12 |
| Rating | 13 |
| Knauf multi-purpose traverses | 14 |
| Knauf steel anchoring traverse with gypsum fibre insert | 16 |
| Knauf Wall gypsum fibre insert 18 | 18 |
| Knauf steel anchoring traverse | 19 |
| Knauf damp room traverse C3 | 20 |
| Knauf Surface traverse – Diamant Steel GKFI | 22 |
| Full-length Sanistand | 23 |
| <hr/> | |
| Loads on board ceilings | |
| Fastening in the cladding / grid | 30 |
| Anchoring in the traverses – Suspended ceilings | 34 |
| Knauf multi-purpose traverses | 34 |

Notes

Notes on the document

Knauf technical information documents are the planning and application basis for planners and professional installers with the application of Knauf systems. The contained information and specifications, constructions, details and stated products are based, unless otherwise stated, on the certificates of usability (e.g. National Technical Test Certificate e.g. abP) valid at the date they are published as well as on the applicable standards. Additionally, design and structural requirements and those relating to building physics (fire resistance and sound insulation) are considered.

The contained construction details are examples and can be used in a similar way for various cladding variants of the respective system. At the same time, the demands made on fire resistance and/or sound insulation as well as any necessary additional measures and/or limitations must be observed.

References to other documents

System data sheets

- [Knauf Metal Stud Partitions W11.de](#)
- [Knauf Wood frame partitions W12.de](#)
- [Knauf Firewalls W13.de](#)
- [Knauf Furring W61.de](#)
- [Knauf AQUAPANEL Metal Stud Partitions® W38.de](#)
- [Knauf AQUAPANEL Furring® W68.de](#)
- [Knauf Board Ceiling D11.de](#)
- [Knauf Cleaneo Acoustic Board Ceilings D12.de](#)
- [Knauf Free-Spanning Ceilings D13.de](#)
- [Knauf Wood Joist Ceiling Systems D15.de](#)
- [Knauf Attic Systems D61.de](#)

Product data sheets

- Observe the product data sheets of the Knauf system components.

Intended use of Knauf Systems

Please observe the following:

| | |
|----------------|---|
| Caution | Knauf systems may only be used in the applications as described in the Knauf documents. In case third-party products or components are used, they must be recommended or approved by Knauf. Flawless application of products / systems assumes proper transport, storage, assembly, installation and maintenance. |
|----------------|---|

Loads on partitions and furrings

Partitions and furrings as drywall constructions are mainly non-load bearing constructions in keeping with the DIN EN 1991 standard. The excellent performance of the Knauf partitions in combination with additional measures such as installed traverses or Diamant Steel offers solutions for the implementation of constructional challenges.

This technical information document contains recommendations for the fastening and fixing of loads on partitions and furrings in the form of:

- Cantilever loads from static superimposed loads (e.g. cabinets, shelves, heating elements, TVs rigidly fixed to the wall)
- Dynamic loads such as handrails, TVs with a swivelling wall mount, folding handles and fold-down seats acc. to DIN 18 040 Construction of accessible buildings
- Attachment of the WC, bidet and washbasin using sanitary mounts in metal stud partitions

Normative definition of the loads on lightweight partitions are defined, for example, in the DIN 4103, DIN 18183 as well as in acc. to Code of Practice No. 8 of the Bundesverband der Gipsindustrie e.V. *German Gypsum Association*.

Cantilever loads as described in the DIN 4103 are considered to be permanent loads and apply, for example, to cabinets.

Dynamic loads are recurring loads effective for a short duration and are time-dependent. Dynamic loads result from folding handles and fold-down seats. For folding handles, a projection of 80 cm with a load of 1.00 kN is assumed for the following recommendations. Fold-down seats are considered as a maximum load of 1.50 kN with a projection of 48 cm.

Sanistands are offered by different manufacturers and are described normatively depending on the application, whether toilet pans or washbasins. The fracture load for toilet pans acc. to the EN 997 stipulates 4.00 kN and for washbasins according to EN 14688 a load of 1.50 kN is stipulated.

The Knauf partition systems in the following have been examined for the case above and determined to be appropriate for the load.

Note

Fasteners in acc. to DIN 4103, section 5.1.5 are to be used. The details contained in this technical information document have been tested in the course of mechanical tests by Knauf.

Differentiation cantilever load / fixing load

Two aspects must be considered in the attachment of loads on partitions and furrings.

Cantilever loads

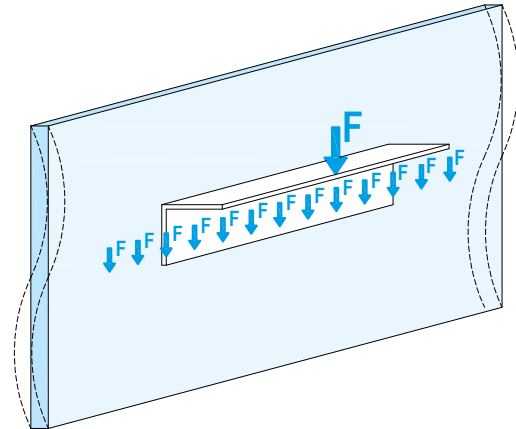

The cantilever load acts as a linear distributed load on the entire wall/partition wall system, i.e. the entire wall system must be specifically designed for the purpose and the load must be transferred to the supporting structure without permitting a structural failure or deformation, which exceed the limits of serviceability.

Fixing loads

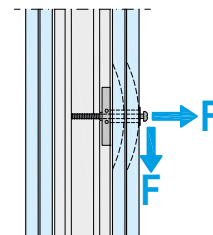

The fastening of attachments (shelves cabinets, mirrors, monitors) to wall systems is undertaken using fasteners such as screws and cavity dowels. The consideration of fastening loads must be for the local wall area and the load bearing capacity of the actual fasteners.

Benefits of the Knauf System

- Regulated construction
- Matched system components
- Diamant Steel GKFI as a surface traverse for flexible attachment in the entire wall area, even with subsequent installation

Cantilever loads

Rating tables / diagrams

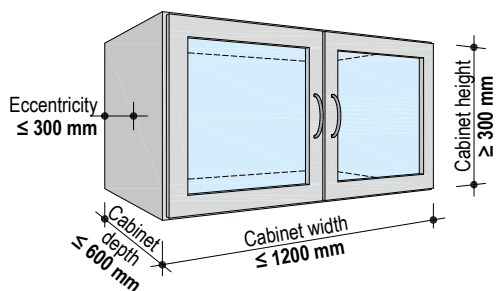

The specified permissible cantilever loads are in accordance with the DIN 18183 or DIN 4103-1 at an eccentricity (spacing of load resulting to the wall surface) of maximum 300 mm. The permissible load is reduced accordingly with greater eccentricity. The following tables and diagrams are intended as an aid in the determination of the permissible cantilever loads with divergent eccentricity. The values can be taken either from the tables or the diagrams.

Fastening spacing of the dowels / screws:

- Acc. to DIN 18183-1: ≥ 75 mm
- Knauf recommendation for approach to the full loadbearing capacity : ≥ 250 mm

Possible cantilever load without traverses – Anchoring in the cladding

Up to 0.4 kN/m (40 kg/m) wall length

Maximum permissible cabinet weight (kg) acc. to table

| Cabinet width mm | Cabinet depth mm | | | | | |
|---------------------|---------------------|-----|------|-----|------|-----|
| | 100 | 200 | 300 | 400 | 500 | 600 |
| 400 | 31 | 28 | 25 | 22 | 19 | 16 |
| 600 | 46.5 | 42 | 37.5 | 33 | 28.5 | 24 |
| 800 | 62 | 56 | 50 | 44 | 38 | 32 |
| 1000 | 77.5 | 70 | 62.5 | 55 | 47.5 | 40 |
| 1200 | 93 | 84 | 75 | 66 | 57 | 48 |

Assume the worst-case value with intermediate values or use the diagram procedure

or

Maximum permissible cabinet weight (kg) acc. to diagram

Max. permissible cabinet weight

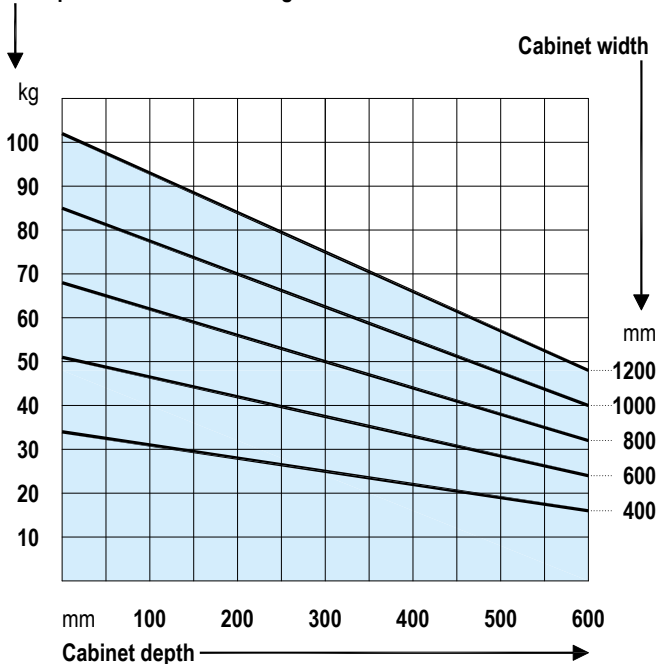

Up to 0.7 kN/m (70 kg/m) wall length

Maximum permissible cabinet weight (kg) acc. to table

| Cabinet width mm | Cabinet depth mm | | | | | |
|---------------------|---------------------|-----|------|-----|------|-----|
| | 100 | 200 | 300 | 400 | 500 | 600 |
| 400 | 43 | 40 | 37 | 34 | 31 | 28 |
| 600 | 64.5 | 60 | 55.5 | 51 | 46.5 | 42 |
| 800 | 86 | 80 | 74 | 68 | 62 | 56 |
| 1000 | 107.5 | 100 | 92.5 | 85 | 77.5 | 70 |
| 1200 | 129 | 120 | 111 | 102 | 93 | 84 |

Assume the worst-case value with intermediate values or use the diagram procedure

or

Maximum permissible cabinet weight (kg) acc. to diagram

Max. permissible cabinet weight

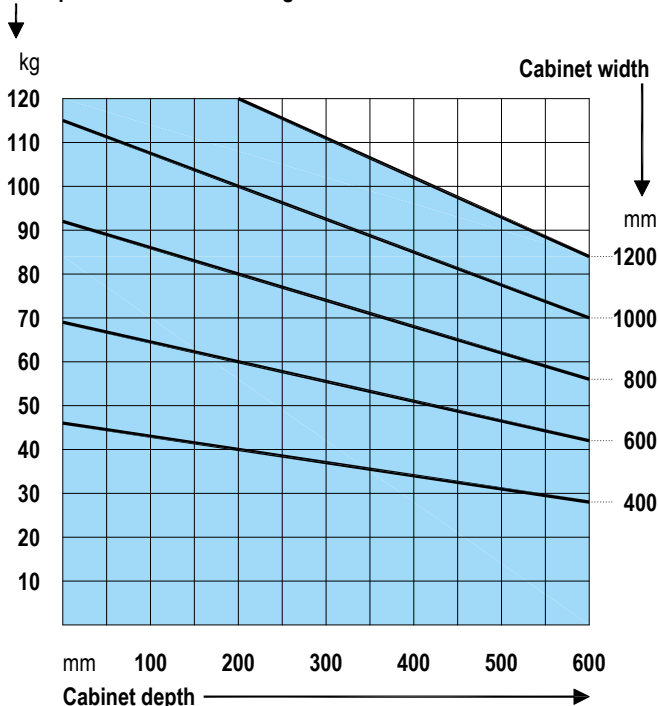

Possible cantilever load with traverses – Anchoring in traverses

Up to 1.0 kN/m (100 kg/m) wall length

Maximum permissible cabinet weight (kg) acc. to table

| Cabinet width mm | Cabinet depth mm | | | | | |
|---------------------|---------------------|-----|-----|-----|-----|-----|
| | 100 | 200 | 300 | 400 | 500 | 600 |
| 400 | 90 | 80 | 70 | 60 | 50 | 40 |
| 600 | 135 | 120 | 105 | 90 | 75 | 60 |
| 800 | 180 | 160 | 140 | 120 | 100 | 80 |
| 1000 | 225 | 200 | 175 | 150 | 125 | 100 |
| 1200 | 270 | 240 | 210 | 180 | 150 | 120 |

Assume the worst-case value with intermediate values or use the diagram procedure

or

Maximum permissible cabinet weight (kg) acc. to diagram

Max. permissible cabinet weight

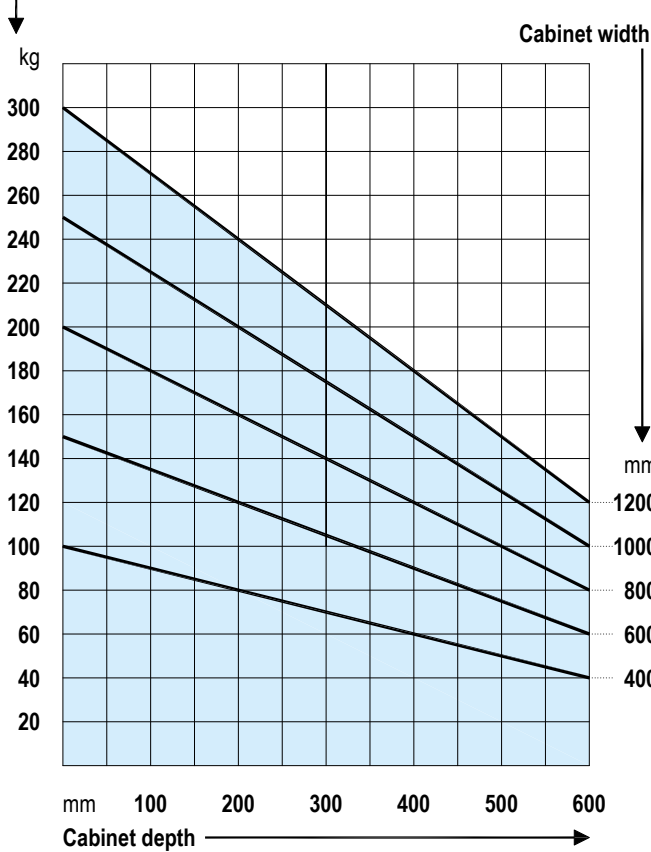

Up to 1.5 kN/m (150 kg/m) wall length

Maximum permissible cabinet weight (kg) acc. to table

| Cabinet width mm | Cabinet depth mm | | | | | |
|---------------------|---------------------|-----|-----|-----|-----|-----|
| | 100 | 200 | 300 | 400 | 500 | 600 |
| 400 | 135 | 120 | 105 | 90 | 75 | 60 |
| 600 | 202 | 180 | 157 | 135 | 112 | 90 |
| 800 | 270 | 240 | 210 | 180 | 150 | 120 |
| 1000 | 337 | 300 | 262 | 225 | 187 | 150 |
| 1200 | 360 | 360 | 315 | 270 | 225 | 180 |

Assume the worst-case value with intermediate values or use the diagram procedure

or

Maximum permissible cabinet weight (kg) acc. to diagram

Max. permissible cabinet weight

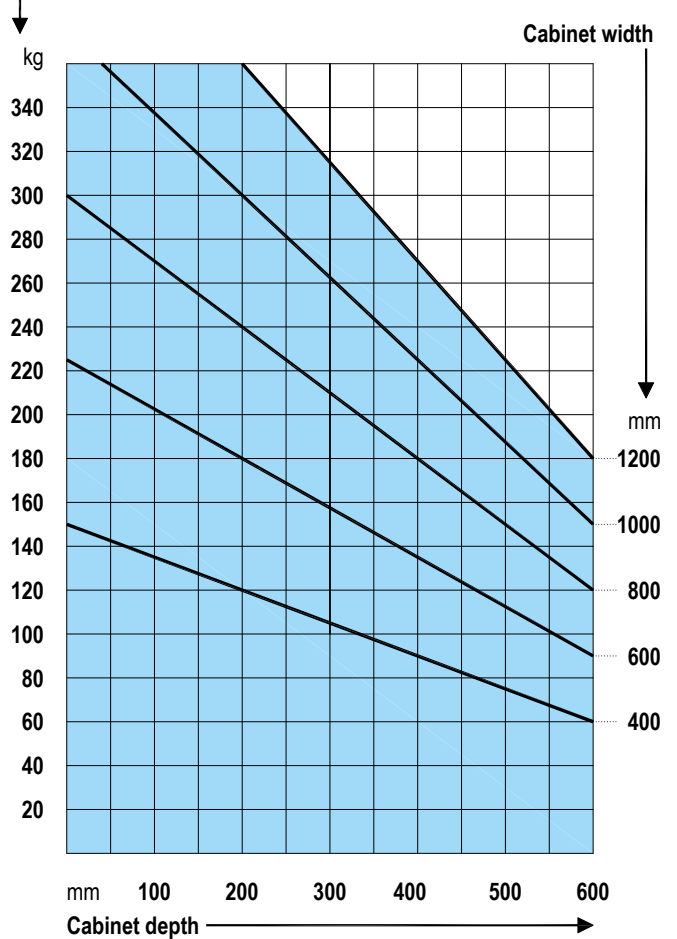

Fields of application

According to DIN 18183, the metal stud partitions and independent furrings can be loaded at any position by cantilever loads:

- Up to 0.4 kN/m (40 kg/m) wall length: Cladding thickness ≥ 12.5 mm Knauf boards
- Up to 0.7 kN/m (70 kg/m) wall length: Cladding thickness ≥ 15 mm Diamant (according to abP P-1405/928/10) / ≥ 18 mm Knauf boards

According to abP P-1101/711/18-MPA BS / abP P-1101/714/18-MPA BS Knauf Metal Stud Partitions AQUAPANEL® and Knauf Furring AQUAPANEL® can be subject to a load at any position by a cantilever load:

- Up to 0.4 kN/m (40 kg/m) wall length: Cladding thickness ≥ 12.5 mm AQUAPANEL® Cement Board Indoor L.E.F.
- Up to 0.7 kN/m (70 kg/m) wall length: Cladding thickness $\geq 2x 12.5$ mm AQUAPANEL® Cement Board Indoor L.E.F.

Selection of the grid in dependence on the expected load

| Maximum load kN/m ² | Load type | Profile At least | Minimum cladding thickness | | | | | | | | | | Furring possible |
|-----------------------------------|-----------|---------------------|----------------------------|---------|--------------------|--|---------------------------------------|---------------|---------|--------------------|--|------------------------------|------------------|
| | | | Loaded side | | | | | Unloaded side | | | | | |
| | | | Knauf boards | Diamant | Diamant Steel GKFI | AQUAPANEL® Cement Board Indoor L.E.F. | Minimum thickness t mm | Knauf boards | Diamant | Diamant Steel GKFI | AQUAPANEL® Cement Board Indoor L.E.F. | Minimum thickness t mm | |
| 0.4 | Static | CW 50 | • | | | | 12.5 | • | | | | 12.5 | Yes |
| | | CW 50 | | • | | | 12.5 | | • | | | 12.5 | Yes |
| | | CW 50 | | | | • | 12.5 | | | | • | 12.5 | Yes |
| 0.7 | Static | CW 50 | | | • | | 12.5 + 0.4 | | • | | | 12.5 | Yes |
| | | CW 50 | | | • | | 12.5 + 0.4 | | | • | | 12.5 + 0.4 | Yes |
| | | CW 50 | | | | • | 2x 12.5 | | | | • | 2x 12.5 | Yes |
| | | CW 75 | • | | | | 18 | • | | | | 18 | Yes |
| | | CW 70 | | • | | | 15 | | • | | | 15 | Yes |
| | | CW 75 | | • | | 15 | | • | | | 15 | Yes | |
| 1.0 | Static | CW 50 | | | • | | 12.5 + 0.4 ¹⁾ + 12.5 | | • | | | 2x 12.5 | Yes |
| | | CW 75 | | | • | | 12.5 + 0.4 | | • | | | 12.5 | No |
| 1.5 | Static | CW 75 | | | • | | 12.5 + 0.4 + 12.5 | | • | | | 2x 12.5 | No |

Always screw fasten Diamant Steel GKFI with Diamant Screws XTB even for a cover layer of Diamant.

One version as W623.de with double cladding (CD channel with Universal Bracket) can be loaded with a cantilever load of 0.4 kN/m. The construction is only intended for static loads.



1) Drywall screw spacing XTB 1st layer Diamant Steel GKFI ≤ 250 mm.

Static loads in this respect are permanently fastened loads such as TVs fixed to the wall, towel rails, cabinets, shelves and boilers.

Walls with dynamic loads are continuously exposed to changes in load, e.g. swivelling wall mount TV, hand rails, folding wall attached seats and folding handles. The use of traverses is required here, see page 11.

Fixing loads

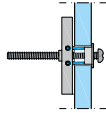
For anchoring of cantilever loads in Knauf gypsum boards

| Dowel / screw | Maximum dowel / screw load capacity in kg | |
|--|---|---|
| | Knauf Cavity Dowel Hartmut M5 screw | Knauf Universalschraube (multi-purpose screw) FN 4.3 x 35 / FN 4.3 x 65 |
| |  |  |
| Knauf Wallboard GKB | | |
| 12.5 mm | 20 | 8 |
| 2x 12.5 mm | 45 | 16 |
| Knauf Piano fire-resistant board GKF / Solidboard GKF | | |
| 12.5 mm | 30 | 10 |
| 25 mm | 60 | 20 |
| 2x 12.5 mm | 60 | 20 |
| Diamant / Silentboard | | |
| 12.5 mm | 40 | 12 |
| 15 mm | 50 | 15 |
| 18 mm | 60 | 20 |
| 2x 12.5 mm | 75 | 40 |
| Diamant Steel GKFI | | |
| 1x 12.5 + 0.4 mm | 80 | 30 |
| 2x 12.5 + 0.4 mm | 100 | 60 |

Measured with 300 mm eccentricity.

For anchoring of cantilever loads in AQUAPANEL® Cement Board

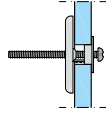
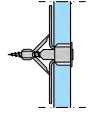
| Dowel / screw | Maximum dowel / screw load capacity in kg | |
|--|---|---|
| | Plastic toggle dowel ¹⁾ | Plastic cavity dowel ¹⁾ |
| |  |  |
| AQUAPANEL® Cement Board Indoor L.E.F. | | |
| 12.5 mm | 25 | 20 |
| 2x 12.5 mm | 40 | 35 |

Measured with 300 mm eccentricity.

¹⁾ Use suitable, certified corrosion protected (galvanized) fasteners.

Application examples – Fasteners

Light objects: e.g. picture frames and mirrors up to 12 kg (12.5 mm Diamant) or up to 40 kg (2x 12.5 mm Diamant) per screw: Knauf Multi-Purpose Screw FN

Higher loads: e.g. Kitchen cupboards up to 75 kg per dowel (2x 12.5 mm Diamant): Knauf Cavity Dowel Hartmut.

Rating

The specified permissible cantilever loads are in accordance with the DIN 18183 or DIN 4103-1 at an eccentricity (spacing of resulting load to the wall surface) of max. 300 mm. The permissible load is reduced accordingly with greater eccentricity. The determination of the permissible cantilever loads with divergent eccentricity is undertaken using the tables or diagrams on page 6 and page 7.

Rating examples

Determination of the permissible cabinet weight as well as the required minimum number of dowels / screws (always ≥ 2)

Metal stud partition W111 DIA70.de, CW 70, cladding 15 mm Diamant GKFI – acc. to table

Field of application: static load, max. cantilever load 0.7 kN/m (70 kg/m) wall length

- Cabinet depth 400 mm, cabinet width 1000 mm → Max. cabinet weight: **85 kg**
- Cladding thickness 15 mm, → Max. dowel load: **50 kg**
Knauf Cavity Dowel Hartmut

Required number of dowels (rounded up)

85 kg : 50 kg = 1.7 → **2 dowels**
are the minimum requirement

| Cabinet width mm | Cabinet depth mm | | | | | |
|---------------------|---------------------|-----|------|-----|------|-----|
| | 100 | 200 | 300 | 400 | 500 | 600 |
| 400 | 43 | 40 | 37 | 34 | 31 | 28 |
| 600 | 64.5 | 60 | 55.5 | 51 | 46.5 | 42 |
| 800 | 86 | 80 | 74 | 68 | 62 | 56 |
| 1000 | 107.5 | 100 | 92.5 | 85 | 77.5 | 70 |
| 1200 | 129 | 120 | 111 | 102 | 93 | 84 |

Metal stud partition W112.de, CW 75, cladding 2x 12.5 mm Knauf Piano fire-resistant board – acc. to diagram

Field of application: static load, max. cantilever load 0.7 kN/m (70 kg/m) wall length

Cabinet depth 450 mm, cabinet width 800 mm

- With cabinet depth 450 mm **1** vertically upwards, up to the cabinet width line 800 mm
- **2** at the intersection point horizontal to the left – read off value **3** : → Max. cabinet weight: **65 kg**
- Cladding thickness 2x 12.5 mm, → Max. dowel load: **60 kg**
Knauf Cavity Dowel Hartmut

Required number of dowels (rounded up)

65 kg : 60 kg = 1.08 → **2 dowels**
are the minimum requirement

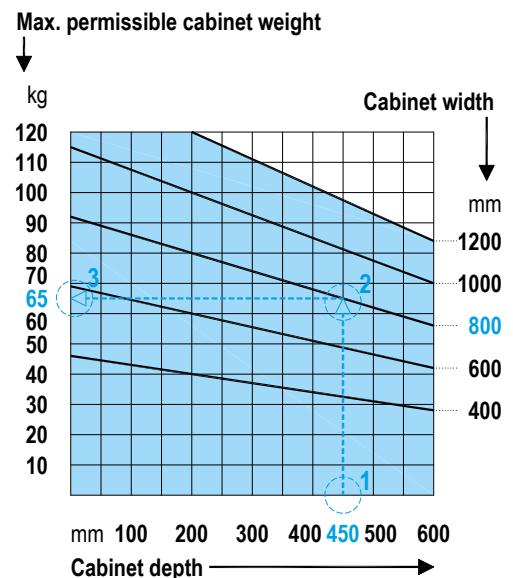

Fields of application

Traverses are built-in elements in lightweight partitions that transfer the fastening loads directly into the grid or into the flanking solid constructions. They facilitate the fixing of larger cantilever loads.

Selection of the traverse and grid in dependence on the expected load

| Fastening | Maximum Load kN/m ² | Load type | Profile At least | Minimum cladding thickness | | | Independent Furring possible |
|---|-----------------------------------|-----------|---------------------|----------------------------|---------------|---|------------------------------------|
| | | | | Knauf boards mm | Diamant mm | AQUAPANEL® Cement Board Indoor L.E.F. mm | |
| Steel Anchoring Traverse See page 19 | 0.7 | Static | CW 50 | 12.5 | 12.5 | – | No |
| | 1.0 | Static | CW 75 | 12.5 | 12.5 | – | No |
| | 1.0 | Static | CW 50 | 18 | 15 | – | Yes |
| Wall insert gypsum fibre 18 See page 18 | 0.7 | Static | CW 50 | 12.5 | 12.5 | – | No |
| | 1.0 | Static | CW 75 | 12.5 | 12.5 | – | No |
| | 1.0 | Static | CW 50 | 18 | 15 | – | Yes |
| | 1.5 | Static | CW 50 | 18 | 15 | – | No |
| Metal traverse with gypsum fibre insert See page 16 | 0.7 | Static | CW 50 | 12.5 | 12.5 | – | No |
| | 1.0 | Static | CW 75 | 12.5 | 12.5 | – | No |
| | 1.0 | Static | CW 50 | 18 | 15 | – | Yes |
| | 1.5 | Static | CW 50 | 18 | 15 | – | No |
| | 1.5 | Static | UA 50 | 18 | 15 | – | Yes |
| | 1.5 | Dynamic | UA 75 | 18 | 15 | – | Yes |
| Multi-purpose traverse See page 14 | 0.7 | Static | CW 50 | 12.5 | 12.5 | – | No |
| | 1.0 | Static | CW 75 | 12.5 | 12.5 | – | No |
| | 1.0 | Static | CW 50 | 18 | 15 | – | Yes |
| | 1.5 | Static | CW 50 | 18 | 15 | – | No |
| | 1.5 | Static | UA 50 | 18 | 15 | – | Yes |
| | 1.5 | Dynamic | UA 75 | 18 | 15 | – | Yes |
| Damp room traverse C3 See page 20 | 0.7 | Static | CW 50 | – | – | 12.5 | No |
| | 0.7 | Static | CW 75 | – | – | 12.5 | Yes |
| | 1.0 | Static | CW 50 | – | – | 2x 12.5 | No |
| | 1.0 | Static | CW 75 | – | – | 2x 12.5 | Yes |
| | 1.5 | Static | CW 75 | – | – | 2x 12.5 | No |

System W111 DIA70.de: Values analog to CW 75 or UA 75.



Notes

Static loads in this respect are permanently fastened loads such as TVs fixed to the wall, towel rails, cabinets, shelves and boilers.

Walls with dynamic loads are continuously exposed to changes in load, e.g. swivelling wall mount TV, hand rails, folding wall attached seats and folding handles.

Fixing loads

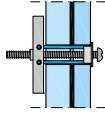
For fixing of cantilever loads

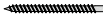
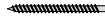
| Dowel / screw | Maximum dowel / screw load capacity in kg | | | |
|---|---|---|--|---|
| | Knauf Cavity Dowel Hartmut Screw M5 | Knauf Multi-Purpose Screw FN 4.3 x 35 / FN 4.3 x 65 | Wood screw Ø 5.0 mm | Wood screw Ø 6.0 mm |
| |  |  |  |  |
| Traverses | | | | |
| Steel Anchoring Traverse | 75 | 45 | – | – |
| Wall insert gypsum fibre 18 | 50 | 50 | – | – |
| Steel Anchoring Traverse with gypsum fibre insert | 90 | 65 | 55 | 70 |
| Multi-purpose traverse | – | 125 | 115 | 165 |

Measured with 300 mm eccentricity.

For fixing of cantilever loads

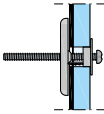
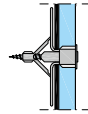
| Dowel / screw | Maximum dowel / screw load capacity in kg | |
|-----------------------|--|--|
| | Plastic toggle dowel ¹⁾ | Plastic cavity dowel ¹⁾ |
| |  |  |
| Traverse | | |
| Damp room traverse C3 | 40 | 35 |

Measured with 300 mm eccentricity.

¹⁾ Use suitable, certified corrosion protected (galvanized) fasteners.

Rating

The specified permissible cantilever loads are in accordance with the DIN 18183 or DIN 4103-1 at an eccentricity (spacing of resulting load to the wall surface) of max. 300 mm. The permissible load is reduced accordingly with greater eccentricity. The determination of the permissible cantilever loads with divergent eccentricity is undertaken using the tables or diagrams on page 6 and page 7.

Rating examples

Determination of the permissible cabinet weight as well as the required minimum number of dowels / screws (always ≥ 2)

Metal stud partition W111.de, CW 50, cladding 18 mm Knauf board – acc. to table

Field of application: static load, max. cantilever load 1.0 kN/m (100 kg/m) wall length

- Cabinet depth 500 mm, cabinet width 800 mm → Max. cabinet weight: **100 kg**
- Steel Anchoring Traverse, Knauf Multi-Purpose Screw FN → Max. screw load: **45 kg**

Required number of dowels (rounded up):

100 kg : 45 kg = 2.2 → **3 screws** are the minimum requirement

| Cabinet width mm | Cabinet depth mm | | | | | |
|---------------------|---------------------|-----|-----|-----|-----|-----|
| | 100 | 200 | 300 | 400 | 500 | 600 |
| 400 | 90 | 80 | 70 | 60 | 50 | 40 |
| 600 | 135 | 120 | 105 | 90 | 75 | 60 |
| 800 | 180 | 160 | 140 | 120 | 100 | 80 |
| 1000 | 225 | 200 | 175 | 150 | 125 | 100 |
| 1200 | 270 | 240 | 210 | 180 | 150 | 120 |

Metal stud partition W112.de, CW 50, cladding 2x 12.5 mm Diamant GKFI – acc. to diagram

Field of application: static load, max. cantilever load 1.5 kN/m (150 kg/m) wall length

Cabinet depth 450 mm, cabinet width 800 mm

- With cabinet depth 450 mm **1** vertically upwards, up to the cabinet width line 800 mm **2** at the intersection point horizontal to the left read off value **3**
- Multi-purpose Traverse, Knauf Multi-Purpose Screw FN → Max. screw load: **125 kg**

Required number of dowels (rounded up):

165 kg : 125 kg = 1.3 → **2 screws** are the minimum requirement

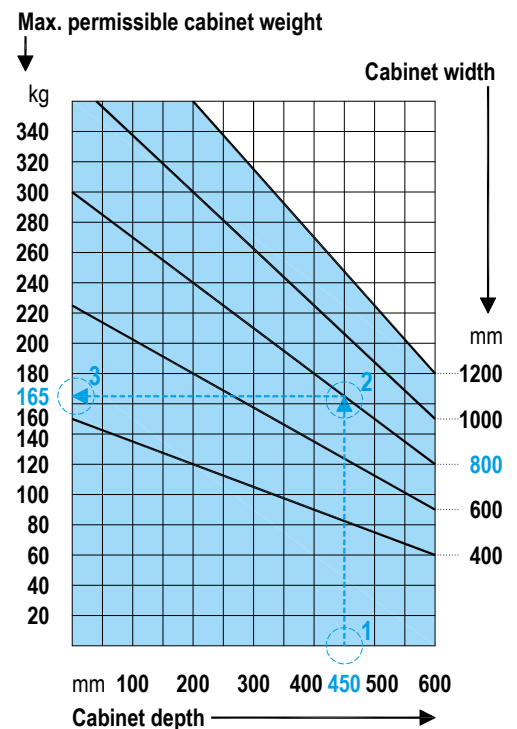

Knauf multi-purpose traverses



Properties and added value

- Premium solution
- 23 mm thick multi-layer wooden board and galvanized sheet metal profiles.
- For static and dynamic loads hanging on the wall up to 1.5 kN/m wall length
- Particularly simple installation
- High fixing loads with Knauf Multi-Purpose Screw FN as well as wood screws
- Arrangement in a row possible
- Suitable for CW and UA profiles
- Suitable as a ceiling traverse (see page 34)

Installation and application

Multi-purpose traverse made of multi-layer wooden board and galvanized sheet metal profiles attached to the side of the CW studs / UA profiles.

For CW studs, screw fasten using the 6 enclosed Metal Screws LN 3.5 x 11 mm (3 per side).

For UA profiles, screw fasten with the 6 enclosed Drilling Screws ST 4.2 x 13 mm (3 per side).

Arrangement in a row

UA profiles

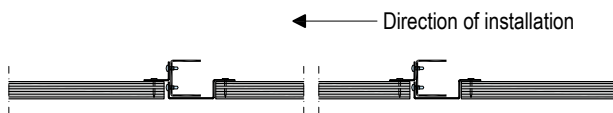

CW studs

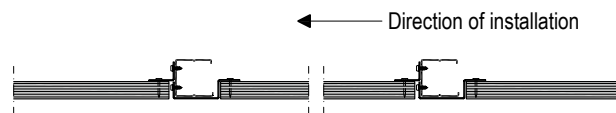

Details

Scale 1:10 | Dimensions in mm

W234.de-A10 View – Design with UA profile

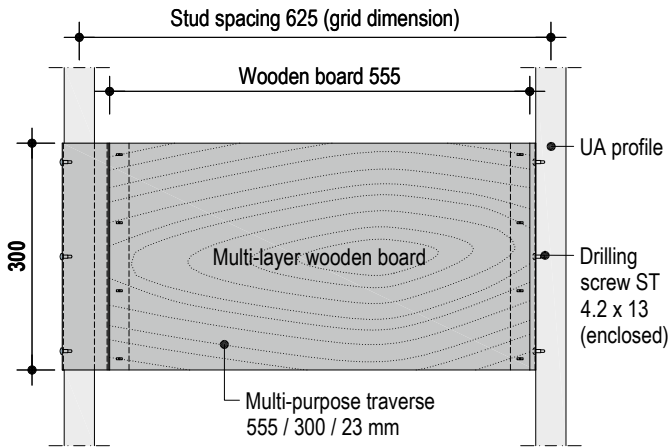

W234.de-A13 View – Design with CW stud

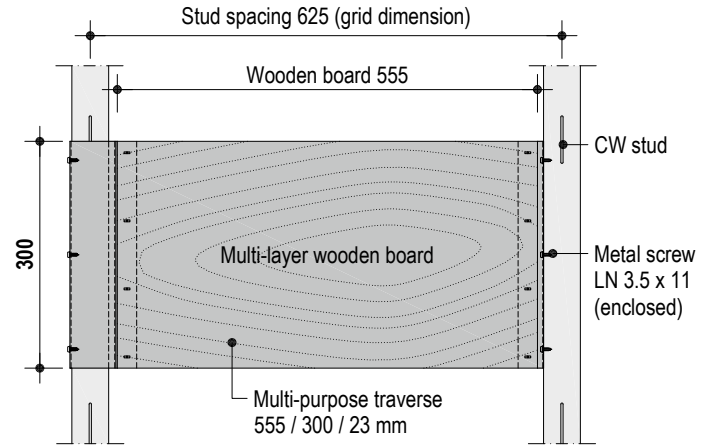

W234.de-H10 Horizontal section – Design with UA profile

e.g. W626.de

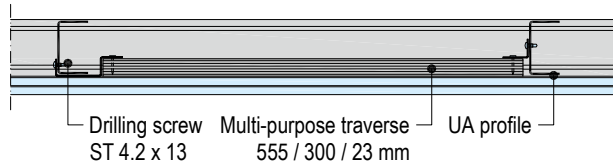

W234.de-H13 Horizontal section – Design with CW stud

e.g. W626.de

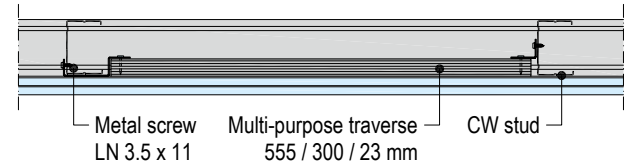

W234.de-V10 Vertical section – Design with UA profile

e.g. W116.de

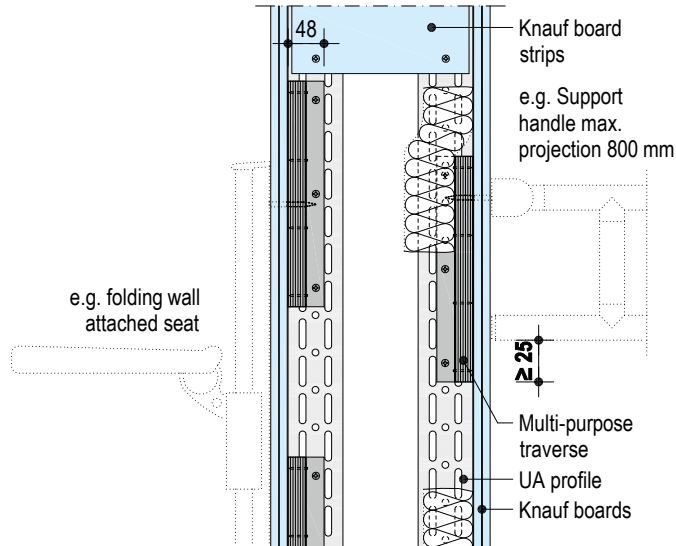

W234.de-V13 Vertical section – Design with CW stud

e.g. W112.de

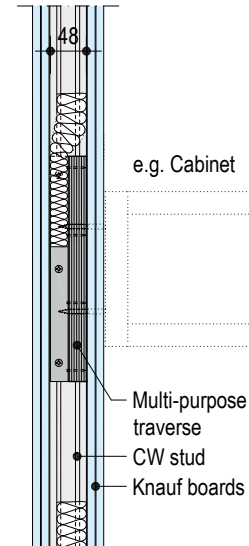

Note

In the case of traverses that are fastened to CW profiles, web cut-outs are not permitted in the traverse area. Additional permissible web cut-outs should have a minimum spacing of 30 cm to the perimeter of the traverse.

Knauf steel anchoring traverse with gypsum fibre insert

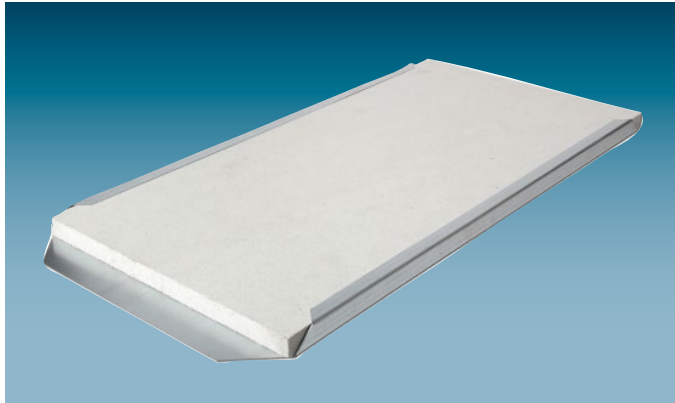

Properties and added value

- Fire protection solution
- Non-combustible
- Metal traverse made of 0.75 mm thick sheet metal with inlay made of 18 mm gypsum fibre board
- For static and dynamic loads hanging on the wall up to 1.5 kN/m wall length
- Easy to install
- Arrangement in a row possible
- Suitable for CW and UA profiles

Installation and application

Steel anchoring traverse made of galvanized steel with gypsum fibre insert fastened to the CW studs / UA profiles. In case of CW studs, crimp using a Stud Crimper and for UA profiles screw fasten with 6 Drilling screws LB 3.5 x 9.5 mm (3 per side).

Arrangement in a row

UA profiles



CW studs



Details

Scale 1:10 | Dimensions in mm

W234.de-A12 View – Design with UA profile

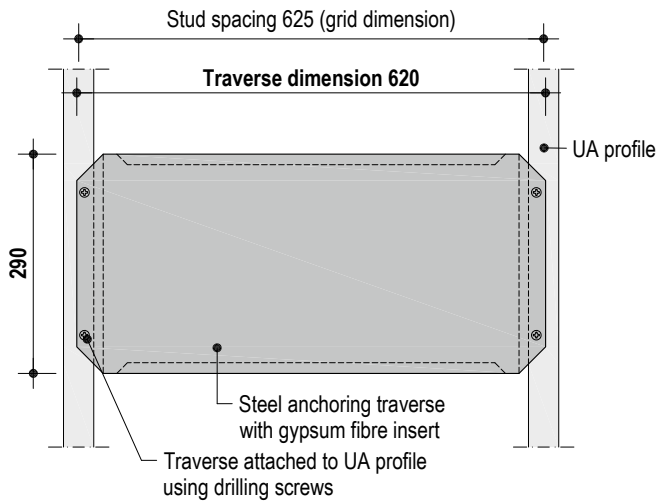

W234.de-A14 View – Design with CW stud

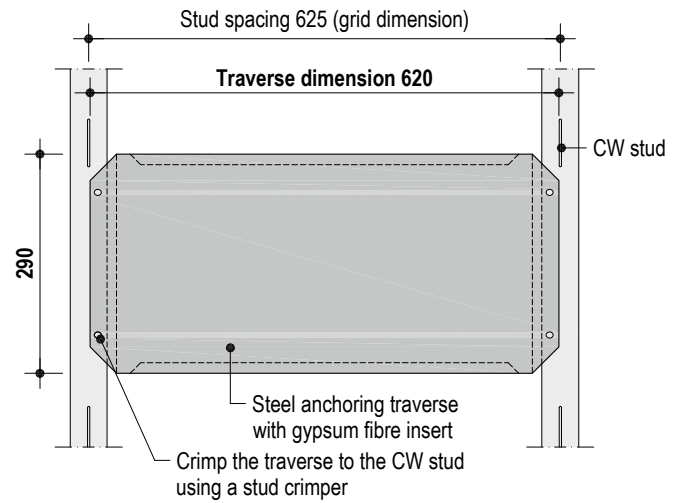

W234.de-H12 Horizontal section – Design with UA profile

e.g. W112.de

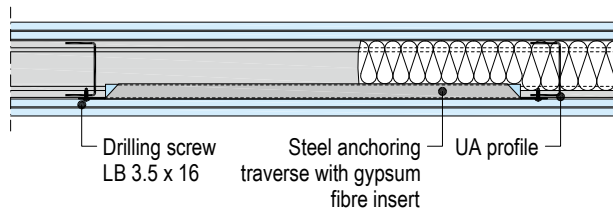

W234.de-H14 Horizontal section – Design with CW stud

e.g. W112.de

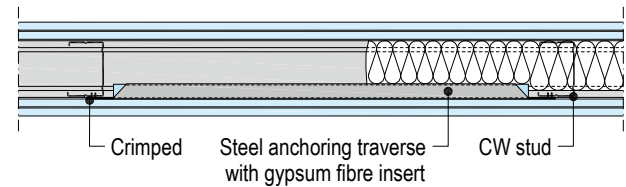

W234.de-V12 Vertical section – Design with UA profile

e.g. W112.de

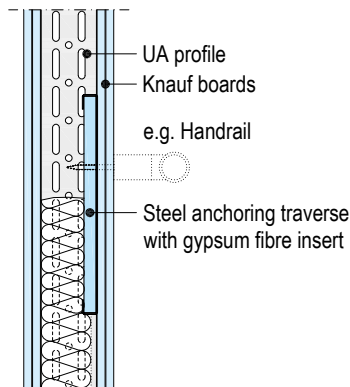

W234.de-V14 Vertical section – Design with CW stud

e.g. W112.de

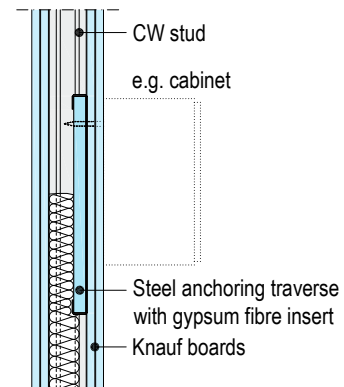

Note

In the case of traverses that are fastened to CW profiles, web cut-outs are not permitted in the traverse area. Additional permissible web cut-outs should have a minimum spacing of 30 cm to the perimeter of the traverse.

Knauf Wall gypsum fibre insert 18

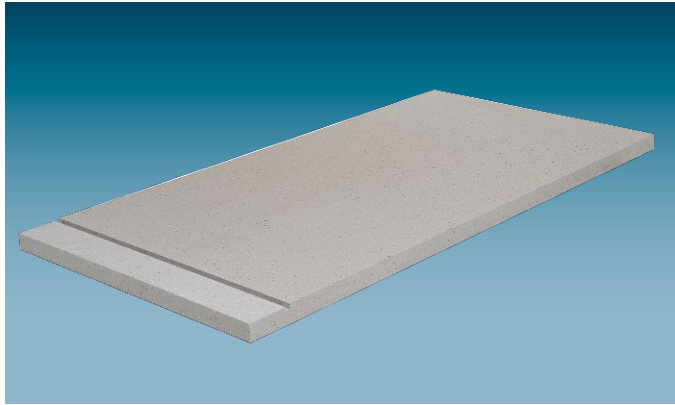

Properties and added value

- Object solution
- Wall insert made of 18 mm gypsum fibre board
- For static loads hanging on the wall up to 1.5 kN/m wall length
- Can be shortened to any length (sawed off) in case of stud spacing < 625 mm
- Custom heights possible
- Non-combustible
- Easy to install
- Suitable as backing for simplified board offset when laying screed
- Arrangement in a row possible
- Suitable for CW profiles

Installation and application

Fasten the wall insert gypsum fibre 18 to the CW studs.

Screw fasten using 6 Drywall Screws TB 3.5 x 35 mm (3 per side). Screw spacing ≤ 150 mm, break-outs are not permitted in case of front side screw fastening.

Arrangement in a row

CW studs

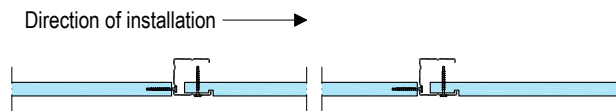

The traverse must be shortened in width depending on the stud spacing.



Details

W234.de-A15 View

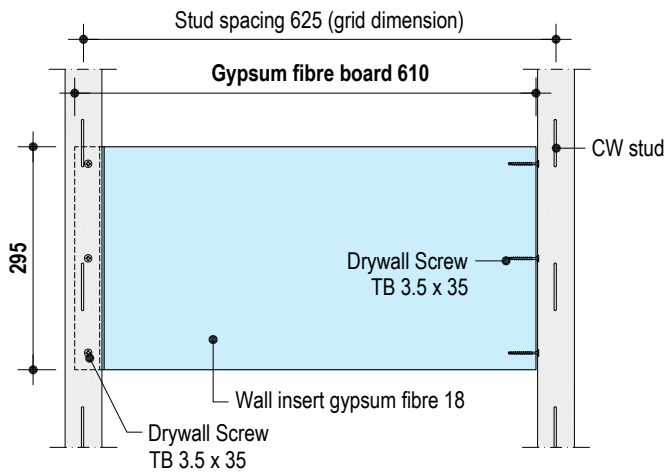

W234.de V15 Vertical section

e.g. W111 DIA70.de

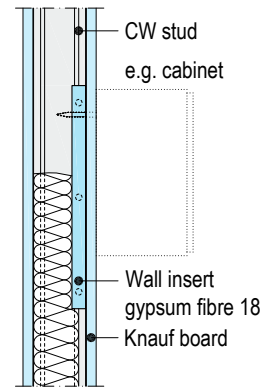

Scale 1:10 | Dimensions in mm

W234.de-H15 Horizontal section

e.g. W626.de

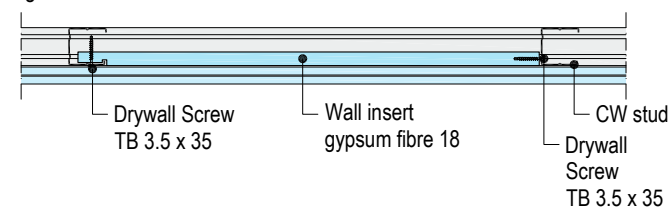

Note

In the case of traverses that are fastened to CW profiles, web cut-outs are not permitted in the traverse area. Additional permissible web cut-outs should have a minimum spacing of 30 cm to the perimeter of the traverse.

Knauf steel anchoring traverse

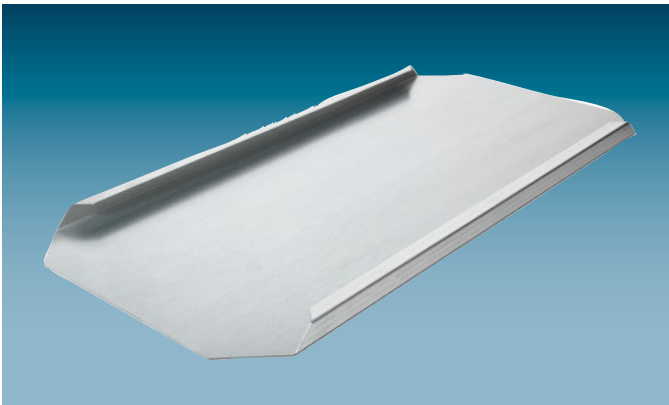

Properties and added value

- Basis solution
- Anchoring traverse made of 0.75 mm thick sheet metal
- For static loads hanging on the wall up to 1.0 kN/m wall length
- Non-combustible
- Easy to install
- Arrangement in a row possible
- Suitable for CW profiles

Installation and application

Crimp the steel anchoring traverse made of galvanized sheet steel to the CW studs using a Stud Crimper.

Additional screw fastening of the steel anchoring traverse via screw fastening of the cladding (min. 2 to 3 anchoring points). Reduce the screw spacing of the cladding if necessary.

Arrangement in a row

CW studs



Details

Scale 1:10 | Dimensions in mm

W234.de-A11 View

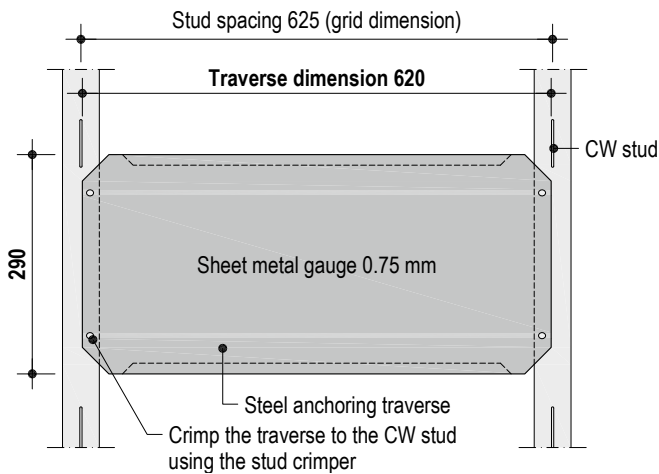

W234.de V11 Vertical section

e.g. W111.de

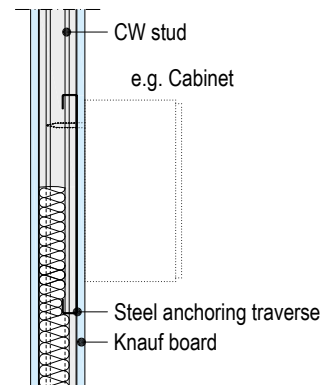

W234.de-H11 Horizontal section

e.g. W111.de

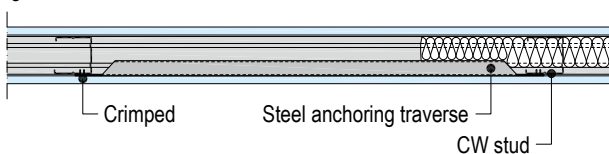

Note

In the case of traverses that are fastened to CW profiles, web cut-outs are not permitted in the traverse area. Additional permissible web cut-outs should have a minimum spacing of 30 cm to the perimeter of the traverse.

Knauf damp room traverse C3

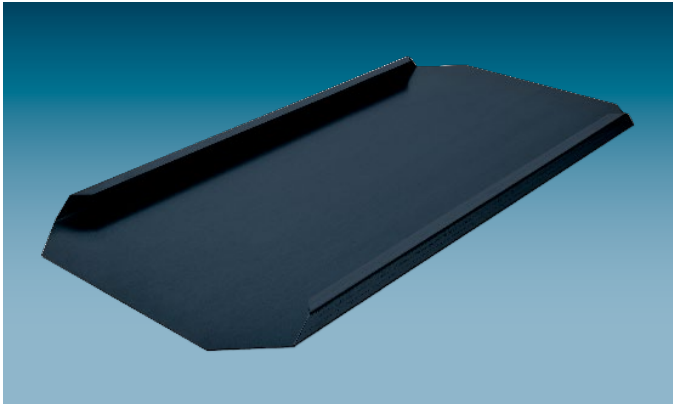

Properties and added value

- Solution for wet and damp rooms
- Corrosion protection C3
- Anchoring traverse made of 1.0 mm thick corrosion protected sheet metal
- For static loads hanging on the wall up to 1.5 kN/m wall length
- Non-combustible
- Easy to install
- Arrangement in a row possible
- Suitable for CW and UA profiles

Installation and application

Fasten the damp room traverse C3 made of sheet metal to the CW studs / UA profiles. In case of CW studs crimp with the Stud Crimper, in case of UA profiles fix using double-sided adhesive tape and then screw fasten using AQUAPANEL® Maxi Screws SB when attaching cladding.

The traverse is additionally fastened crosswise via the cover layer with 5 screws and in the profile area with at least 2 screws per traverse side.

Arrangement in a row

UA profiles

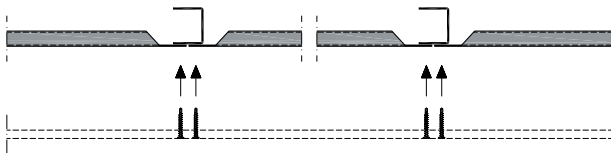

CW studs



Scale 1:10 | Dimensions in mm

W234.de-A16 View – Design with UA profile

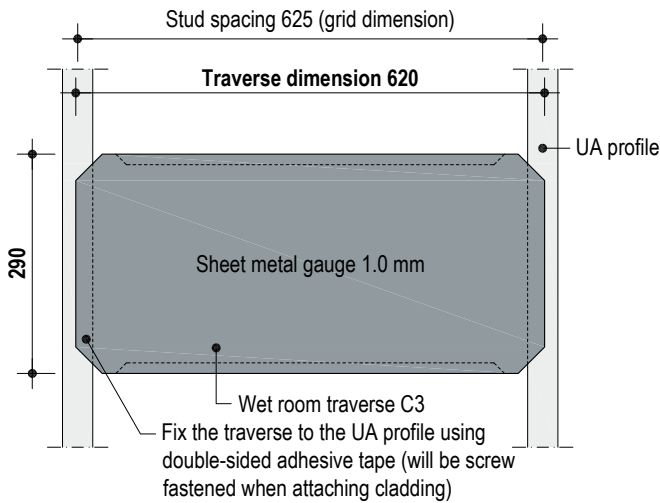

W234.de-A17 View – Design with CW stud

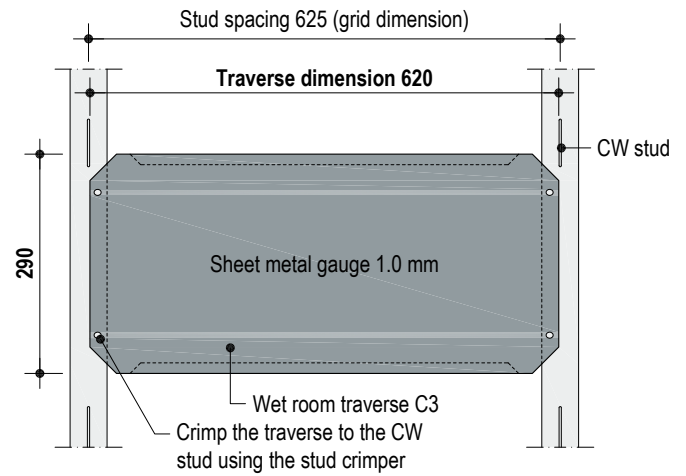

W234.de-H16 Horizontal section – Design with UA profile

e.g. W382.de

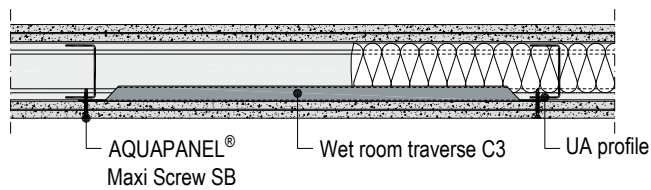

W234.de-H17 Horizontal section – Design with CW stud

e.g. W381.de

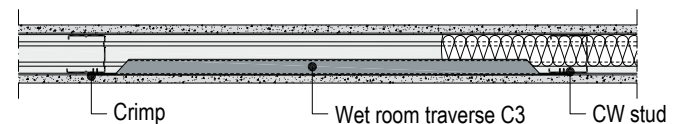

W234.de-V16 Vertical section – Design with UA profile

e.g. W382.de

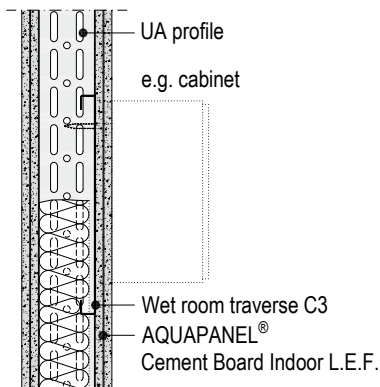

W234.de-V17 Vertical section – Design with CW stud

e.g. W381.de

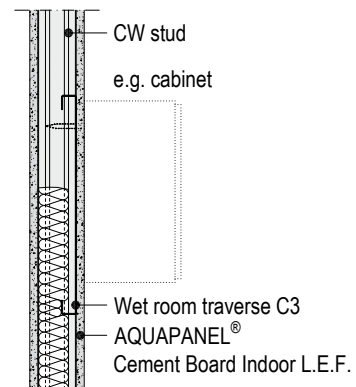

Note

In the case of traverses that are fastened to CW profiles, web cut-outs are not permitted in the traverse area. Additional permissible web cut-outs should have a minimum spacing of 30 cm to the perimeter of the traverse.

Knauf Surface traverse – Diamant Steel GKFI

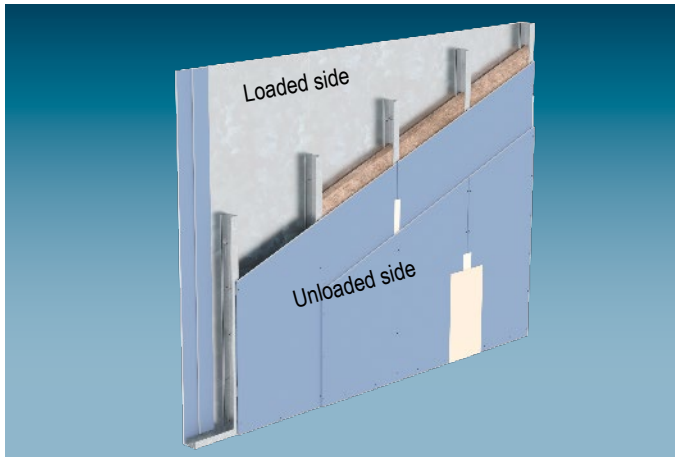

Properties and added value

- Surface traverse
- Non-combustible
- Diamant Steel GKFI: 12.5 mm Diamant with a 0.4 mm sheet metal lamination
- For static loads hanging on the wall up to 1.5 kN/m wall length
- Flexible attachment in the entire wall area
- Suitable for remodeling / retrofitting

Scheme drawing

Examples

Scale 1:10

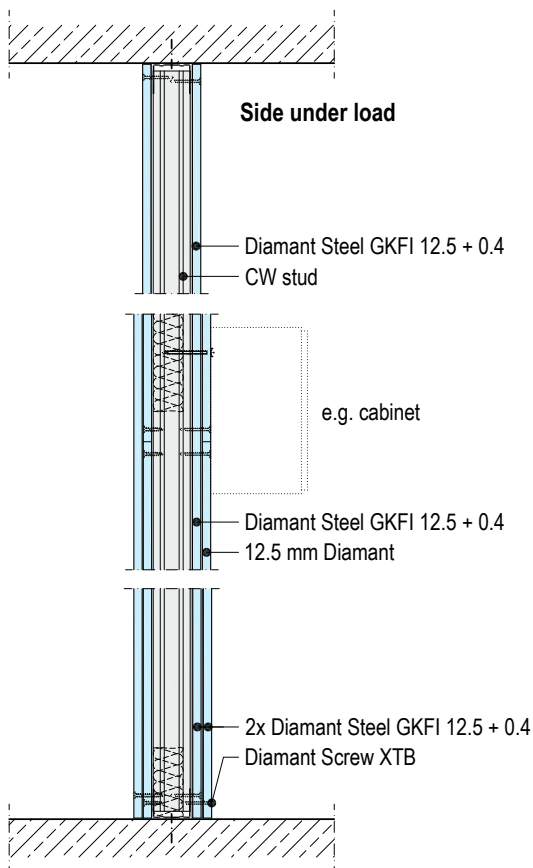

Notes

Design of the surface traverse (metal grid with Diamant Steel GKFI cladding) acc. to system data sheet [Knauf Metal Stud Partitions W11.de](http://KnaufMetalStudPartitionsW11.de)

Additional web cut-outs in the local load introduction area are not permissible.

Full-length Sanistand



Floor-to-ceiling Sanistands made of galvanized UA profiles (min. UA 75), 2 mm thick, are suitable for transferring loads from traverses into the supporting structure or for fixing loads hanging on walls such as school blackboards, up to 1.5 kN/m wall length.

The loads are connected directly to the flange of the UA profile.

Installation and application

Floor-to-ceiling Sanistands made of UA profiles must be anchored to the basic floor and ceiling with door frame brackets or connection brackets for UA profiles. The upper door frame bracket includes openings for routing cables such as pipe-in-pipe systems or electrical cables.

Fasten objects to UA profiles using threaded rods, U washers and M10/12 steel nuts or self-tapping screws.

Detail

W228.de-A10 View

Scale 1:10

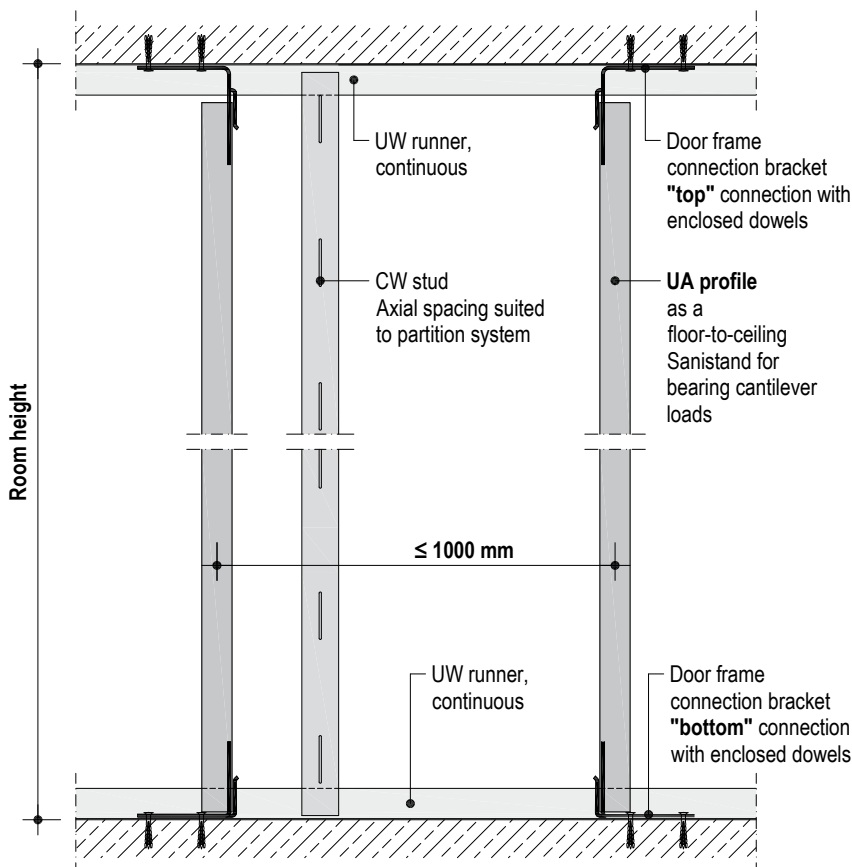

| | |
|--------------|--|
| Notes | Web cut-outs are not permissible in UA Sanistand subject to cantilever loads, point loads or linear distributed loads. |
| | Maximum screw load with connections to full height Sanistand (UA profile): |
| | Every UA profile flange and anchoring point may not exceed a resulting pull-out load of 1.50 kN (150 kg). |
| | Components similar to cantilevers such as foldable rails should be screwed onto two adjacent UA profiles. |
| | Use suitable drilling screws. |

Details

Scale 1:10

W116.de-V1 Sanistand

Vertical section I Without fire resistance

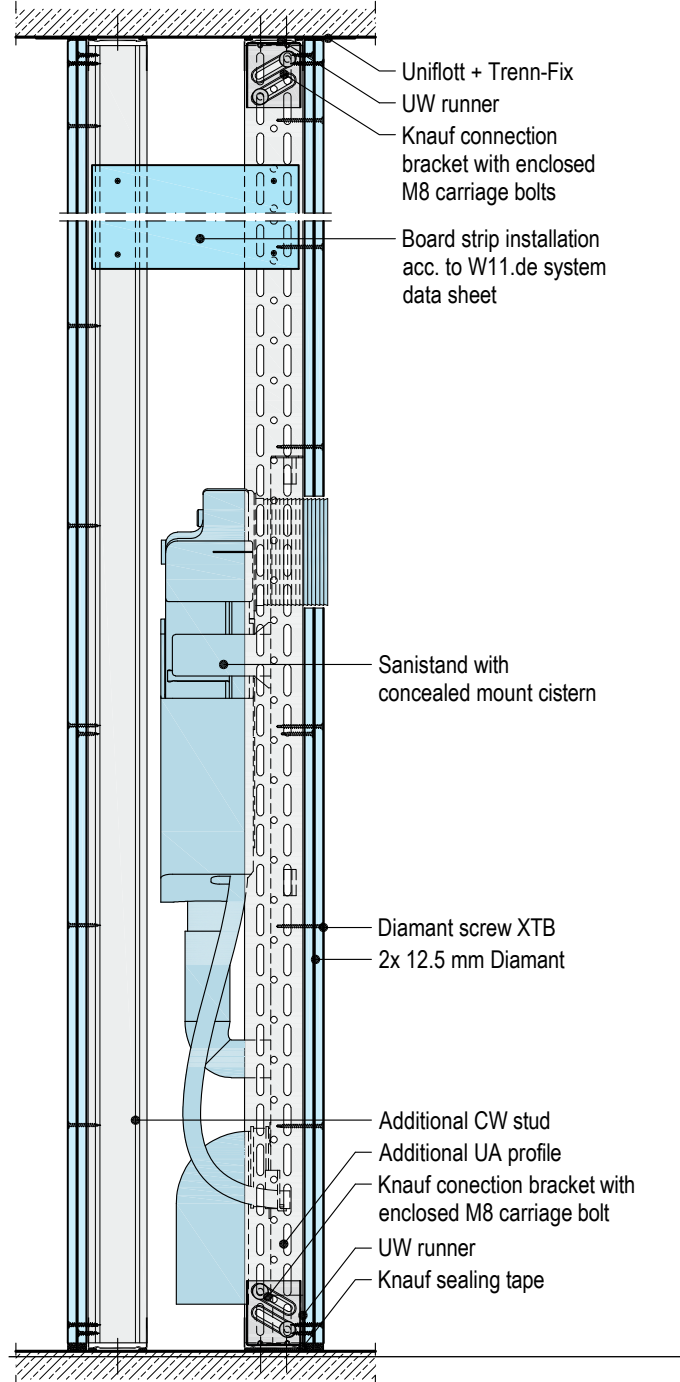

W116.de-H1 Sanistand

Horizontal section I Without fire resistance

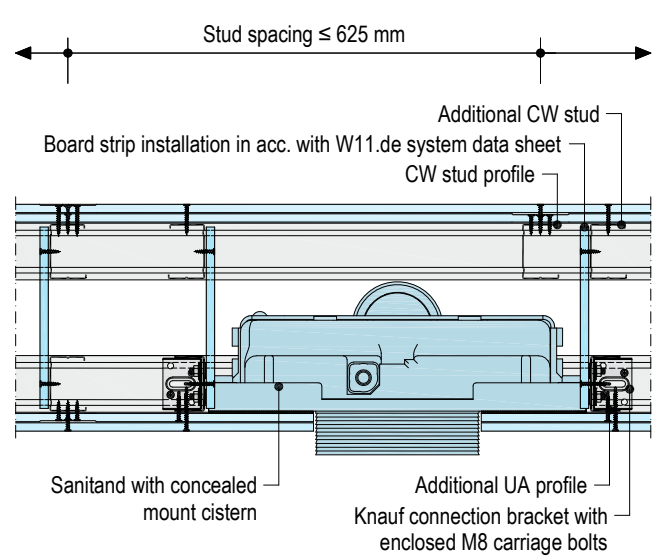

Notes

Maximum partition height:

- UA 50 = 3.00 m (not applicable in case of installation on toilet pan in barrier free sanitary facilities)
- UA 70 and \geq UA 75: See system data sheet [Knauf Metal Stud Partition W11.de for wall heights](#)

Minimum cladding:

- ≥ 15 mm Diamant / ≥ 18 mm Knauf boards, recommendation 2x 12.5 mm Knauf Diamant
- 2x 12.5 mm AQUAPANEL® Cement Board Indoor L.E.F.
- Observe the manufacturers specifications for cladding and lateral UA profiles.

Web cut-outs are not permissible in UA Sanistand subject to cantilever loads, point loads or linear distributed loads.

Additional UA profiles are required laterally on Sanistand mounts acc. to DIN 18340 section 3.7.4.

Only possible without additional UA profiles if the manufacturer of the Sanistand base or WC Sanistand permits it.

Deviating specifications of the Sanistand manufacturer must be considered and observed.

Details

Scale 1:10

W626V.de-V2 Back anchoring in traverse

Vertical section

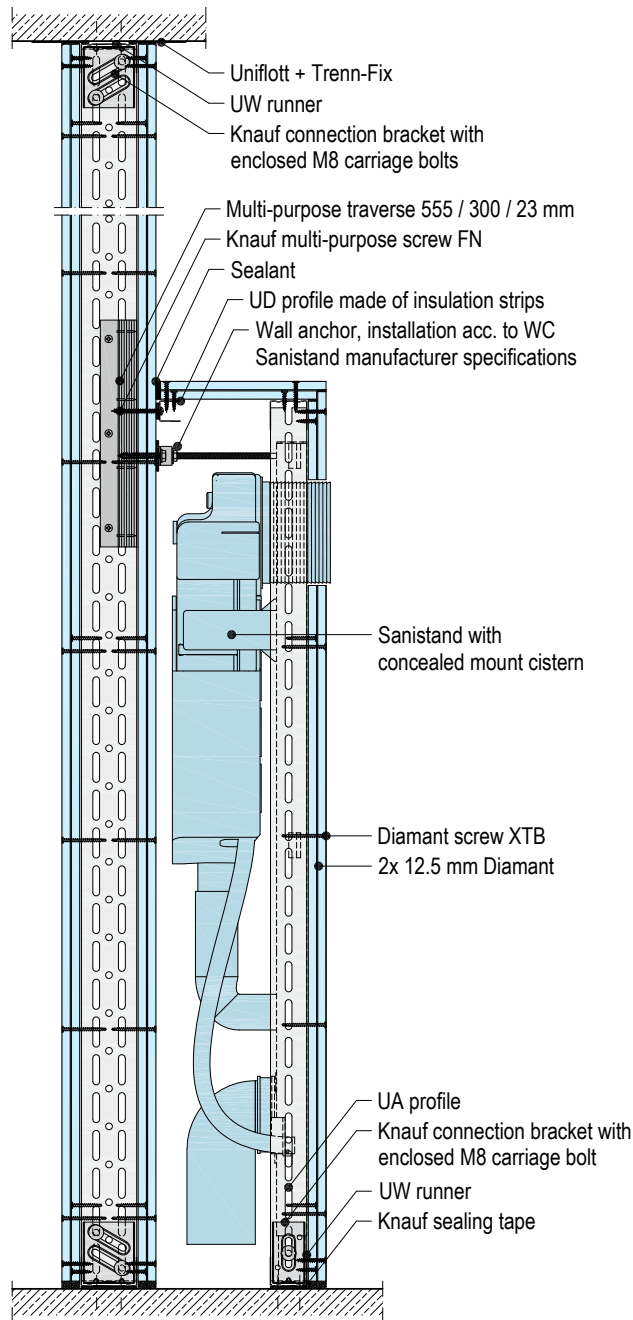

W626V.de-H2 Back anchoring in traverse

Horizontal section

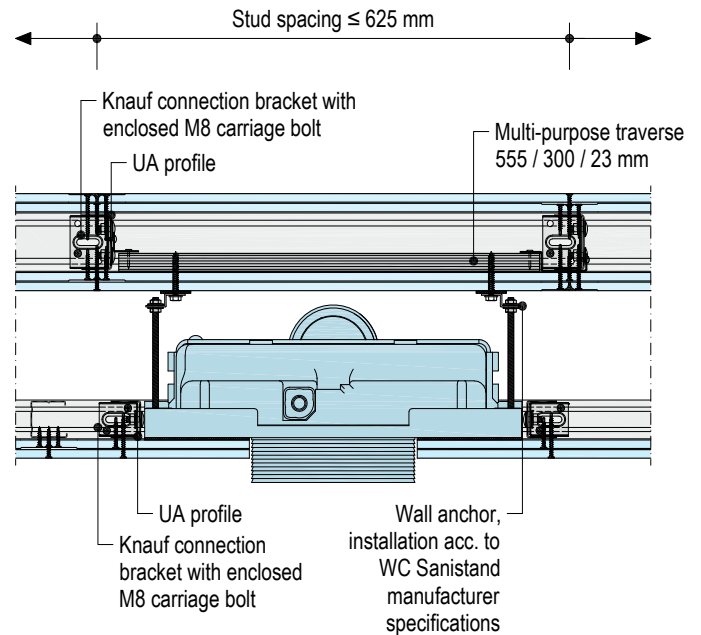

| | |
|---|---|
| Notes | Maximum partition height rear W112.de: |
| | <ul style="list-style-type: none"> ■ UA 50 = 3.00 m (not applicable in case of installation on toilet pan in barrier free sanitary facilities) ■ UA 70 and ≥ UA 75: See system data sheet Knauf Metal Stud Partition W11.de for wall heights |
| | Minimum cladding front wall installations: |
| | <ul style="list-style-type: none"> ■ ≥ 15 mm Diamant / ≥ 18 mm Knauf boards, recommendation 2x 12.5 mm Knauf Diamant ■ 2x 12.5 mm AQUAPANEL® Cement Board Indoor L.E.F. ■ Observe the manufacturers specifications for cladding and lateral UA profiles. |
| | Web cut-outs are not permissible in UA Sanistand subject to cantilever loads, point loads or linear distributed loads. |
| | Additional UA profiles are required laterally on Sanistand mounts acc. to DIN 18340 section 3.7.4. Only possible without additional UA profiles if the manufacturer of the Sanistand base or WC Sanistand permits it. |
| Deviating specifications of the Sanistand manufacturer must be considered and observed. | |

Details

Scale 1:10

W626V.de-V3 Back anchoring in UA profile

Vertical section

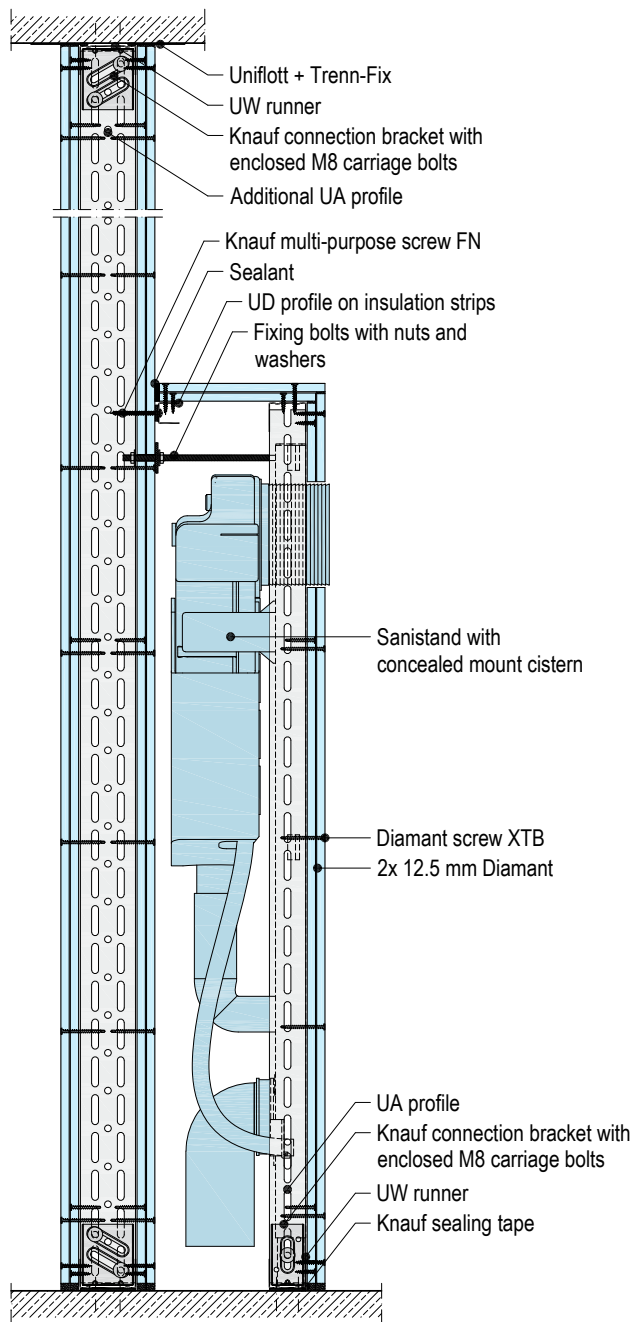

W626V.de-H3 Back anchoring in UA profile

Horizontal section

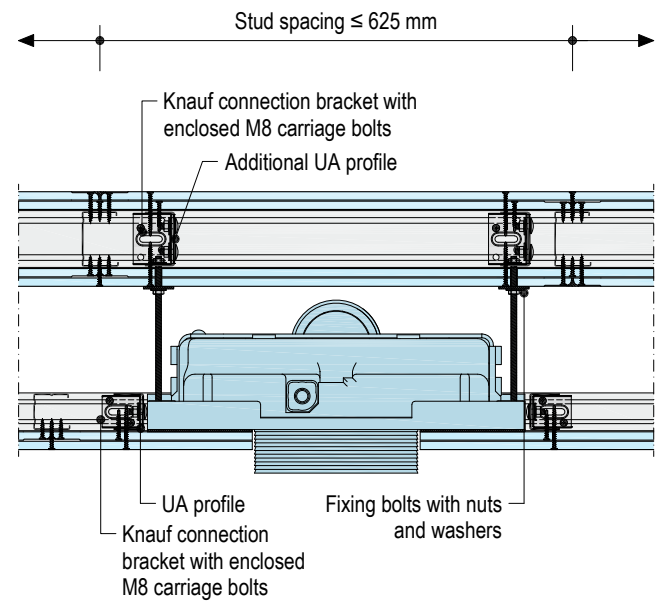

Notes

Maximum partition height rear W112.de:

- UA 50 = 3.00 m (not applicable in case of installation on toilet pan in barrier free sanitary facilities)
- UA 70 and ≥ UA 75: See system data sheet [Knauf Metal Stud Partition W112.de for wall heights](https://www.knauf.com/Products/Accessories/Partition-Accessories/W112.de)

Minimum cladding front wall installations:

- ≥ 15 mm Diamant / ≥ 18 mm Knauf boards, recommendation 2x 12.5 mm Knauf Diamant
- 2x 12.5 mm AQUAPANEL® Cement Board Indoor L.E.F.
- Observe the manufacturers specifications for cladding and lateral UA profiles.

Web cut-outs are not permissible in UA Sanistand subject to cantilever loads, point loads or linear distributed loads.

Additional UA profiles are required laterally on Sanistand mounts acc. to DIN 18340 section 3.7.4.

Only possible without additional UA profiles if the manufacturer of the Sanistand base or WC Sanistand permits it.

Deviating specifications of the Sanistand manufacturer must be considered and observed.

Details

Scale 1:10

W626V.de-V4 Back anchoring in mounting rail

Vertical section

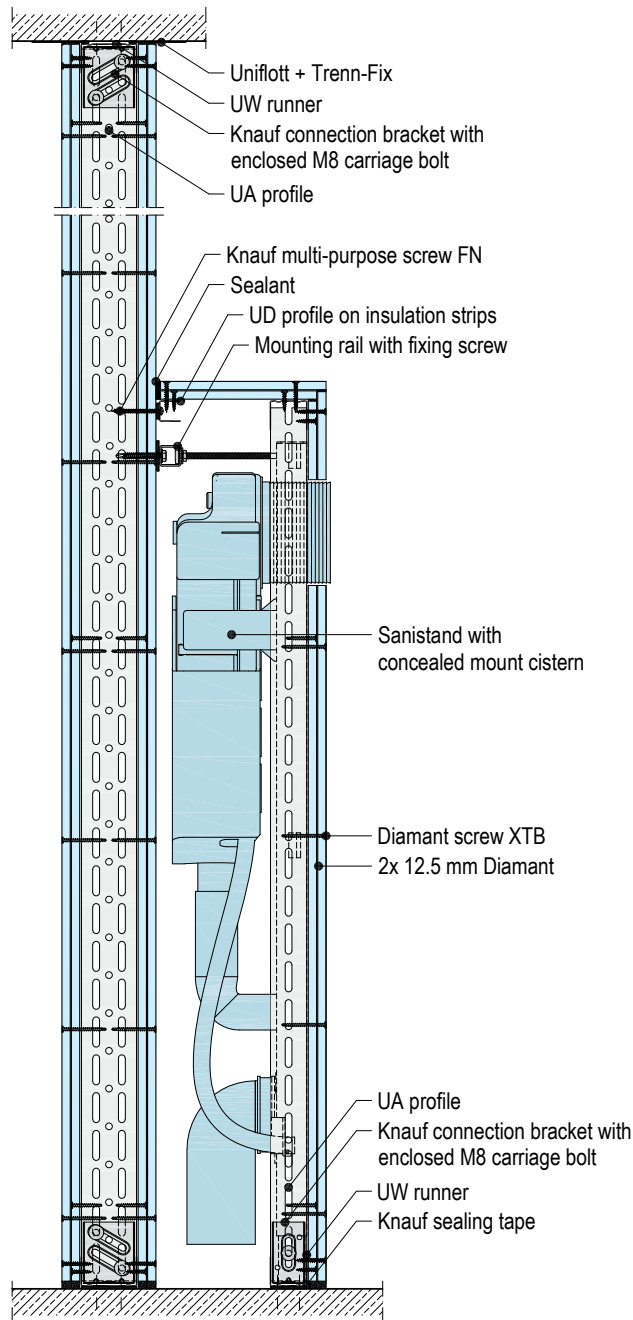

W626V.de-H4 Back anchoring in mounting rail

Horizontal section

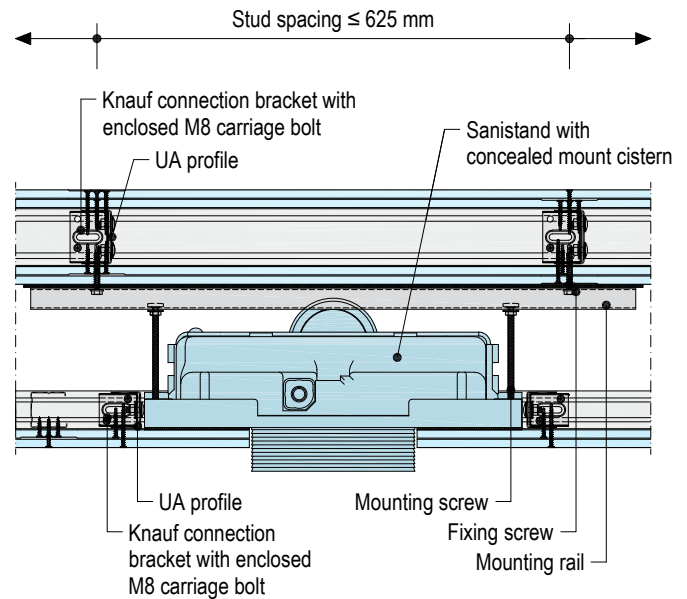

| | |
|--|---|
| Notes | Maximum partition height rear W112.de: |
| | <ul style="list-style-type: none"> ■ UA 50 = 3.00 m (not applicable in case of installation on toilet pan in barrier free sanitary facilities) ■ UA 70 and ≥ UA 75: See system data sheet Knauf Metal Stud Partition W11.de for wall heights |
| | Minimum cladding front wall installations: |
| | <ul style="list-style-type: none"> ■ ≥ 15 mm Diamant / ≥ 18 mm Knauf boards, recommendation 2x 12.5 mm Knauf Diamant ■ 2x 12.5 mm AQUAPANEL® Cement Board Indoor L.E.F. ■ Observe the manufacturers specifications for cladding and lateral UA profiles. |
| | Web cut-outs are not permissible in UA Sanistand subject to cantilever loads, point loads or linear distributed loads. |
| Additional UA profiles are required laterally on Sanistand mounts acc. to DIN 18340 section 3.7.4. | |
| Only possible without additional UA profiles if the manufacturer of the Sanistand base or WC Sanistand permits it. | |
| Deviating specifications of the Sanistand manufacturer must be considered and observed. | |

Attachment of loads to Knauf ceilings

Additional loads, e.g. lamps, curtain rails and similar can be fixed to Knauf ceilings using universal dowels, cavity dowels, spring toggle dowels or Knauf Hartmut cavity dowels. The weight of additional loads must be considered when planning the ceiling.

| | |
|--------------|---|
| Notes | Heavy loads must be e.g. traverses anchored directly on load-bearing building elements (basic ceiling) or on auxiliary constructions. |
| | As an alternative for free-spanning ceilings, separate rating of the maximum room widths is possible on request. |

The weight of the fastened components may not exceed following thresholds:

| Permissible weight per ceiling surface in kg/m ² | | |
|---|-------------------------|----------------------|
| Knauf Free-Spanning Ceiling | Without fire resistance | With fire resistance |
| Suspended board ceilings / cladding (D11.de / D15.de / D61.de) | 15 | 6 ¹⁾ |
| Suspended acoustical board ceiling (D12.de) | 15 | 6 |
| Free-spanning acoustical board ceiling (D12.de) | 3 | 3 |
| Free-Spanning Ceilings (D13.de) With application of the room widths including | | |
| 3 Kg/m ² additional load | 3 | 3 |
| 15 Kg/m ² additional load | 15 | 6 ¹⁾ |

1) In case of application as a fire resistance ceiling with exposed ceiling (multi-level ceiling system), 15 kg/m² is permissible as the total weight for the exposed ceiling (including insulation layer and attached loads) attached to the fire resistance ceiling.

Furthermore, the following conditions apply:

For every anchoring point, the following weights of components attached to the Knauf ceiling may not be exceeded:

| Permissible weight per anchoring point in kg | Without fire resistance | | With fire resistance | |
|---|---------------------------|-----------------------|---------------------------|-----------------------|
| | Fastening in the cladding | Fastening to the grid | Fastening in the cladding | Fastening to the grid |
| Knauf Free-Spanning Ceiling | | | | |
| Suspended board ceilings / cladding (D11.de / D15.de / D61.de) | 6 | 10 | 0.5 | 10 |
| Suspended acoustical board ceiling (D12.de) | 0.5 ²⁾ | 10 | 0.5 | 10 |
| Free-spanning acoustical board ceiling (D12.de) | 0.5 ²⁾ | 3 | 0.5 | 3 |
| Free-Spanning Ceilings (D13.de) With application of the room widths including | | | | |
| 3 Kg/m ² additional load | 3 | 3 | 0.5 | 3 |
| 15 Kg/m ² additional load | 6 | 10 | 0.5 | 10 |

2) Fastening in the claddings not permissible with Cleaneo UFF plaster base board

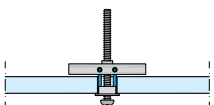
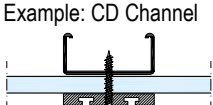
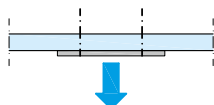
| Fastening in the cladding | Fastening to the grid | Note |
|---|---|--|
|  <p>Knauf Hartmut Hohlraumdübel cavity dowel Screw M5</p> |  <p>Example: CD Channel Knauf Multi-purpose screw FN e.g. curtain rail</p> |  <p>The attached loads can be introduced with several anchoring elements.</p> |

Minimum spacing of the anchoring points

The minimum separation spacings between individual attached loads must be observed to avoid local overloading of the ceiling. The minimum spacing between two anchoring points is dependent on both effective radii of the individual loads.

The effective radius of the individual load can be taken from the following diagram in dependence on the permissible weight per unit area for additional loads:

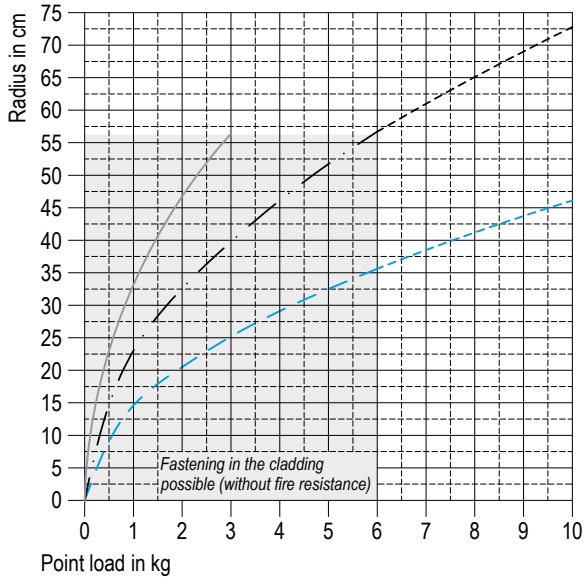

Suspended ceilings

- 3 kg/m² additional loads (on the exposed ceiling under a fire resistance ceiling, refer to the respective valid Knauf system data sheets)
- - - 6 kg/m² additional loads (with fire resistance)
- · · 15 kg/m² additional loads (without fire resistance)

Free-Spanning Ceilings D13.de

- 3 kg/m² additional load (application of the room widths up to 3 kg/m²)
- - - 6 kg/m² additional load (application of the room widths up to 15 kg/m² with fire resistance)
- · · 15 kg/m² additional load (application of the room widths up to 15 kg/m² without fire resistance / in case of Multi-level Ceiling System)

Example fastening scheme at 15 kg/m²

Suspended board ceiling

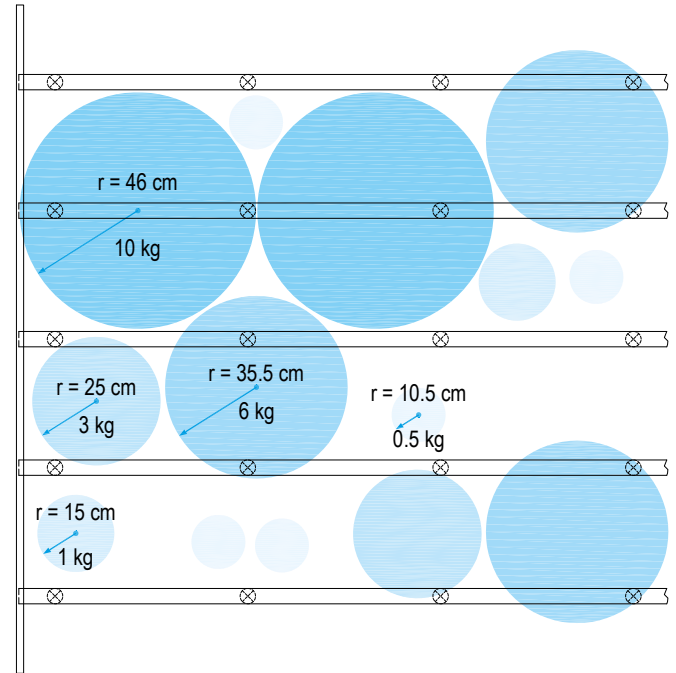

Suspended acoustical board ceiling

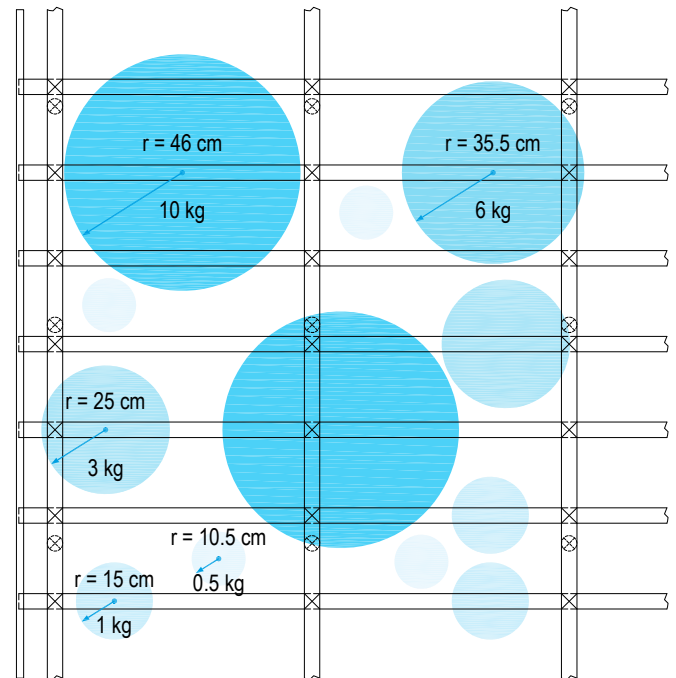

Rating example

e.g. Built-in/air-conditioning unit

- Dimension a x b: 850 x 850 mm
- Number of anchoring points: 4 pieces
- Weight: approx. 26 kg
- Fastening to the grid (furring channel)

Selected ceiling

- Knauf Board Ceiling D112.de
- cladding: 2x 12.5 mm Knauf Wallboard
- Without fire resistance

Dimensioning principles

With suspended Knauf ceiling systems:

To read off the required spacings for the grid, it is first of all necessary to determine the load class taking into consideration the self-weight of the selected system variant including any existing or planned additional loads.

Step 1:

Determination of the rated weight (See the respective system data sheet).

The rated weight (cladding with grid) of the suspended ceiling/ceiling lining can be read off from the Knauf system tables in dependence on the selected cladding thickness (system variants).

| Fire resistance class | Cladding | | Rated weight kg/m ² | Furring channel Max. axial clearances (b) | Insulation layer required for fire resistance | |
|--|-----------------|----------------------------|-----------------------------------|---|---|-------------------|
| | Knauf Wallboard | Fire-Resistant Board | | | Without insulation layer | Minimum thickness |
| | | mm | | | mm | kg/m ³ |
| D112.de Knauf board ceiling with metal grid | | | | | | |
| | • | 1x 12.5 | 11.7 | 500 | - | |
| | • | 2x 12.5 | 21.1 | | | |
| F... | • | 2x 12.5 | 24.3 | 500 | | Without or |

Step 2:

Consideration of additional loads

Additional loads, e.g. consisting of fire resistance necessary and unnecessary insulation materials, as well as planned fixing loads, increase the total area weight of the ceiling lining / suspended ceiling and must be considered with the rating of the load class.

(Rated weight + weight of additional loads = total area weight)

Each load introduction surface of the Knauf board ceiling may not exceed the weight threshold values with the fastened components: (See page 30)

Permissible weight per ceiling surface in kg/m²

| Knauf ceiling | Without fire resistance | With fire resistance |
|---------------|-------------------------|----------------------|
| D112.de | 15 | 6 |

Note

To obtain a small minimum fixing distance (radius from the diagram) for ceilings without fire resistance, a higher additional load (e.g. maximum 15 kg/m²) can already be assumed when dimensioning the grid.

Step 3:

Determination of the load class (See respective system data sheet).

Based on the resulting total area load of the ceiling lining / suspended ceilings, the corresponding load class (kN/m²) can be determined from the load class diagram.

Determination of the load class

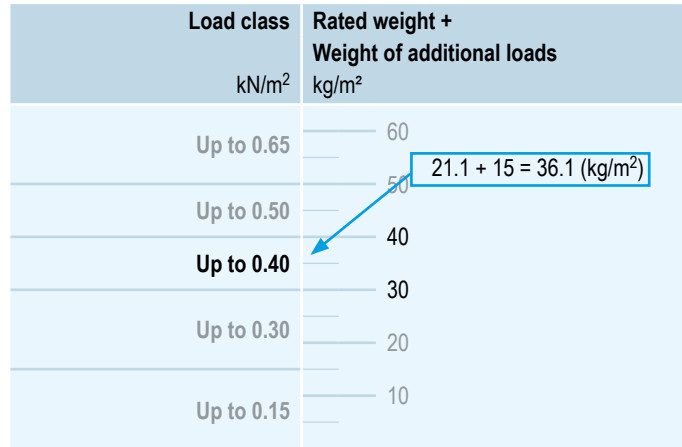

The self-weight of the ceiling may not exceed 0.50 kN/m². The load class up to 0.65 kN/m² may only be used in combination with additional loads, e.g. multi-level ceiling system. Rated acc. to DIN 18168-1.

Step 4:

Dimensioning of the grid (See respective system data sheet)

Using the determined load class, the maximum permissible spacings of the suspenders (a) as well as the profiles (b) can be read off (c) from the tables "System variants" and "Maximum grid spacings" depending on the fire resistance requirements and the selected grid/frame.

| Axial spacings furring channel (b) | Suspender spacings (a) | | | | |
|---------------------------------------|---------------------------------|------------|------------|------------|------------|
| | Load class in kN/m ² | | | | |
| | Up to 0.15 | Up to 0.30 | Up to 0.40 | Up to 0.50 | Up to 0.65 |
| 400 | 1400 | 1150 | 1050 | 1000 | 900 |
| 500 | 1300 | 1050 | 950 | 900 | 850 |
| 625 | 1200 | 1000 | 900 | 850 | 800 |

With free-spanning Knauf ceiling systems:

The maximum room widths result from the profile size / profile type / cladding + additional loads considered (3 kg/m² or 15 kg/m²). (See the respective system data sheet)

Step 5:

Observe the maximum weight of the anchoring point

For each anchoring point, the components fastened to the board ceiling may not exceed the following weights: (See page 30).

Permissible weight per anchoring point in kg

| Knauf ceiling | Without fire resistance | |
|---------------|---------------------------|-----------------------|
| | Fastening in the cladding | Fastening to the grid |
| D112.de | 6 | 10 |

Rating example – Continued

Step 6:

Observing the minimum spacings of the fixing loads

Air-conditioning unit = 26.0 kg

Anchoring points = 4 pcs

26.0 kg / 4 pcs. = 6.5 kg Individual load per anchoring point

The minimum separation spacings between individual attached loads must be observed to avoid local overloading of the ceiling.

(See page 31)

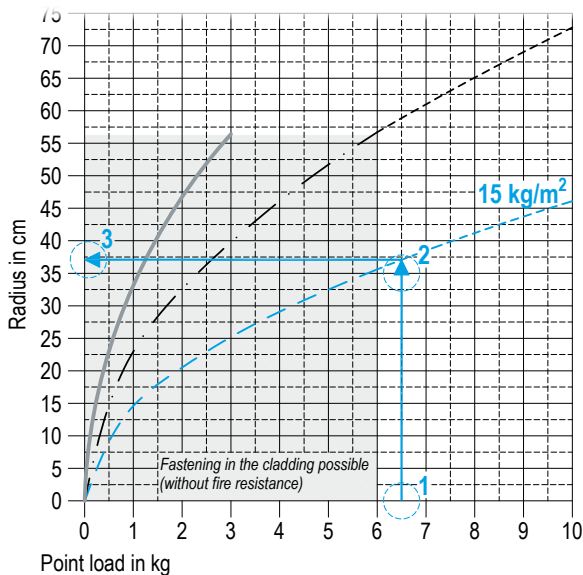

--- 15 kg/m² Additional weight (without fire resistance)

Read off value:

With a single load 6.5 kg (1) vertically upwards to the curve 15 kg/m² permissible additional weight (2) in this intersection point horizontal to the left

Read off (3) → Radius: 37 cm

Required minimum spacing of the anchoring points:

37 cm + 37 cm = 74 cm

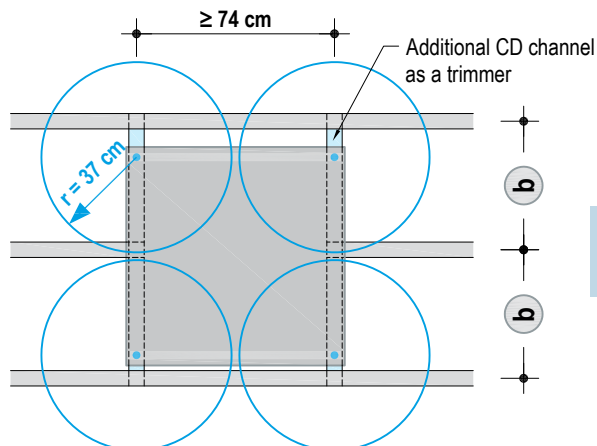

The effective radii do not intersect – the minimum spacing is observed.

Non permissible rating example

Step 1:

Determination of the rated weight

24.3 kg/m² (2x 12.5 mm Knauf Piano Fire-Resistant Board)

Step 2:

Consideration of additional loads

6 kg/m²

Step 3:

Determination of the load class

24.3 kg/m² + 6 kg/m² = 30.3 kg/m² = load class up to 0.40 kN/m²

Step 4:

Dimensioning of the grid

Read off the spacings of the suspenders and profiles

Step 5:

Observe the maximum weight of the anchoring point

Step 6:

Observing the minimum spacings of the fixing loads

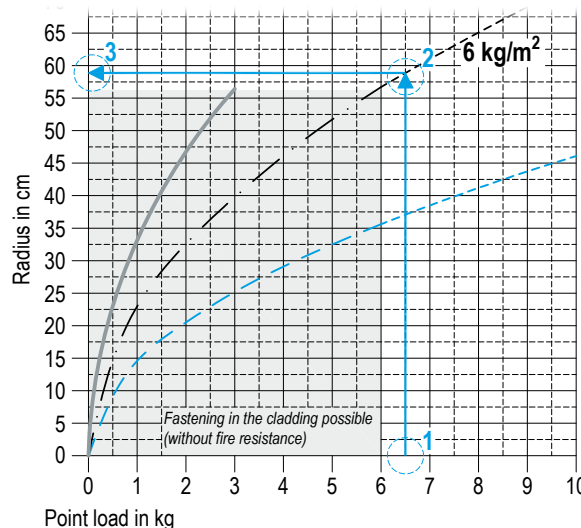

--- 6 kg/m² Permissible additional weight (with fire resistance)

Read off value:

Radius: 58.5 cm

Required minimum spacing of the anchoring points:

58.5 cm + 58.5 cm = 117 cm

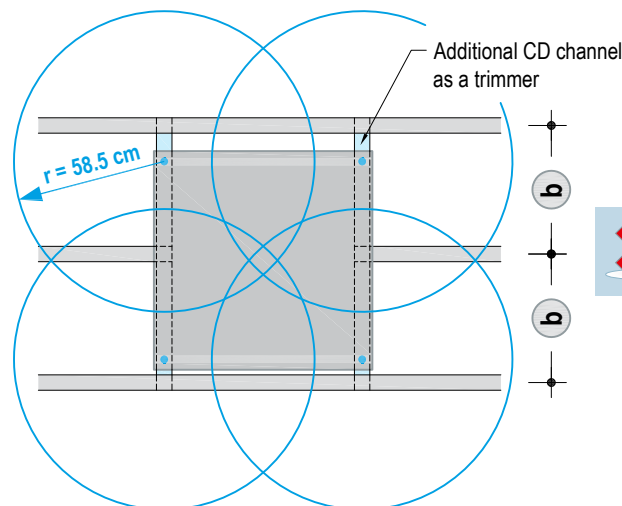

The effective radii intersect – the minimum spacing is not observed.

Knauf multi-purpose traverses

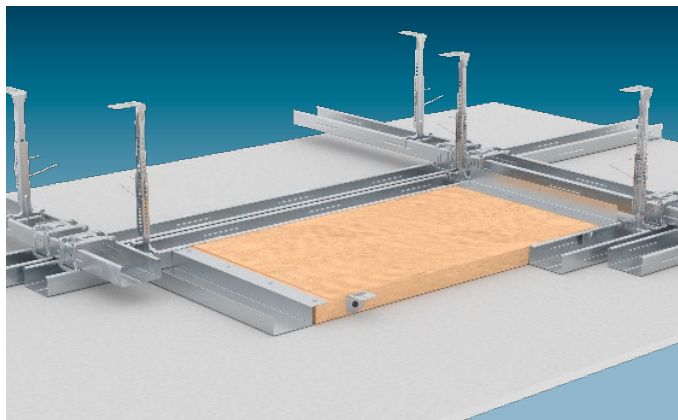

Properties and added value

- Ceiling traverse
- 23 mm thick multi-layer wooden board and galvanized sheet metal profiles.
- For point loads up to 0.75 kN, e.g. chandeliers, juke boxes, etc.
- Reliable solution
- Fastening of the loads, preferably with Multi-Purpose Screw FN
- Installation in doubled or flush grids

Installation and application

Bend the Daisy chain clip before lateral screw fastening. The Daisy chain clip is then Z shaped. The unpunched metal side of the Daisy chain clip is pushed onto the lower side of the traverse and then screw fastened laterally through the factory-made hole on the long side of the traverse. Screw fasten 2 Daisy Chain Clips on each of the long sides of the multi-layer wooden board. Fastening is undertaken using Drywall Screw TN 3.5 x 35 at spacing of approx. 100 mm from the corner of the multi-layer wooden board. Arrange an additional CD channel (length ≥ 650 mm) for every long edge in accordance with the width of the multi-purpose traverse. Alternately, a ceiling furring channel can be used for application of the multi-purpose traverse.

The supporting profiles are suspended using ceiling suspenders of load class 0.40 kN. The suspenders may not be situated in the direct vicinity of the longitudinal area of the traverse as this will hinder the installation of the traverse.

Introduce the multi-purpose traverse between the support profiles, bend the Daisy chain clip around the CD channel and engage it. In case of single-layer cladding do not screw fasten the surface cladding with the multi-purpose traverse.

1. Apply the Daisy chain clip

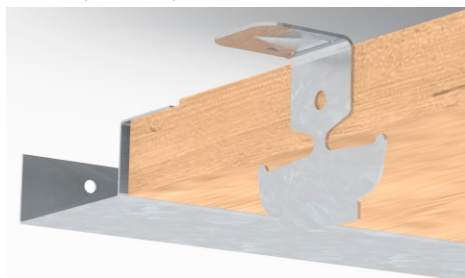

2. Bend the Daisy chain clip

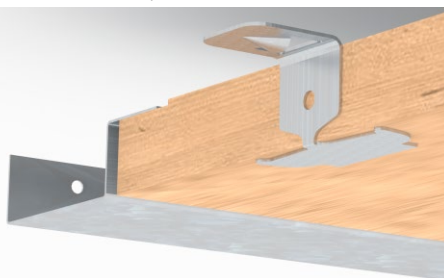

3. Screw fasten the Daisy chain clip

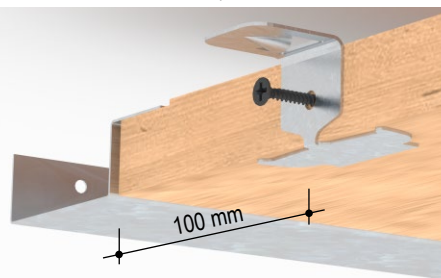

Scale 1:10 | Dimensions in mm

Details

D112.de SO18 Vertical section – Multi-purpose traverse

e.g. with two additional CD channels | Without fire resistance

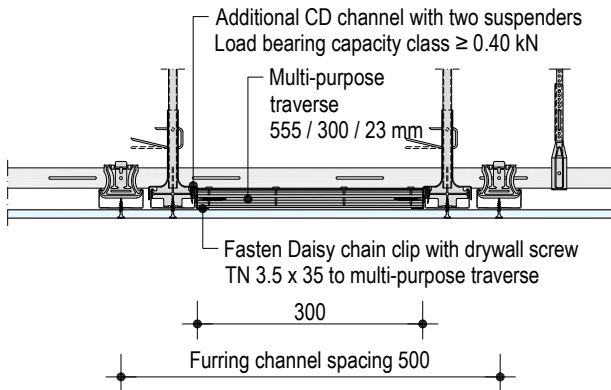

D113.de SO12 Vertical section – Multi-purpose traverse

e.g. with one additional CD channel | Without fire resistance

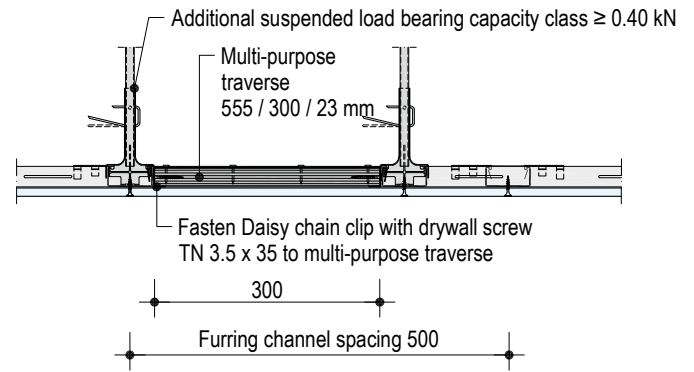

D112.de SO19 Vertical section – Multi-purpose traverse

e.g. with two additional CD channels | Without fire resistance

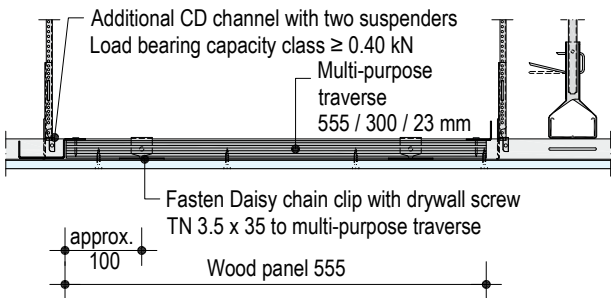

D113.de SO13 Vertical section – Multi-purpose traverse

e.g. with one additional CD channel | Without fire resistance

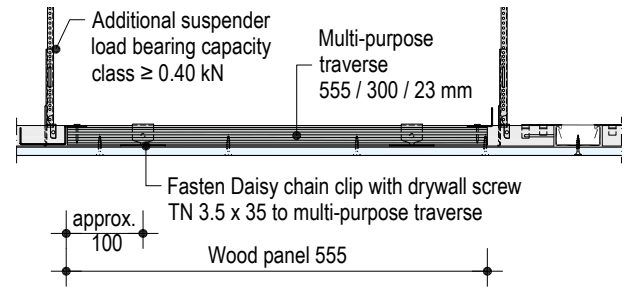

D112.de SO20 Top view – Multi-purpose traverse

e.g. with two additional CD channels | Without fire resistance

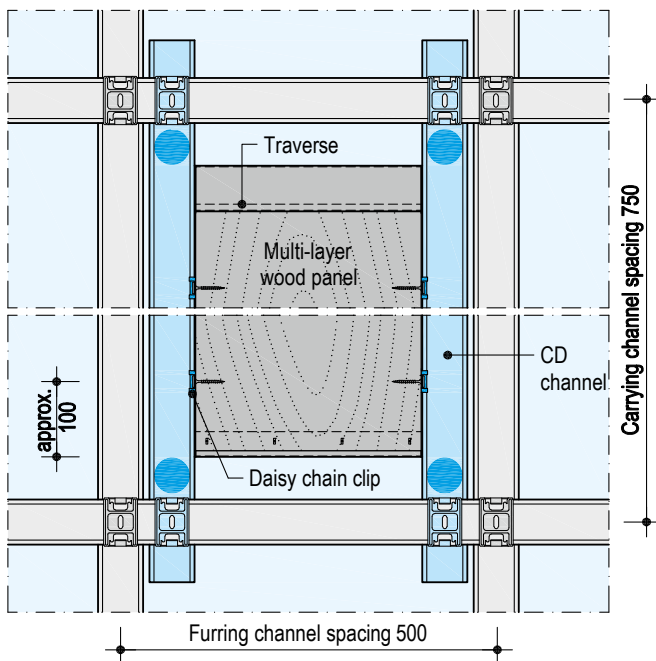

D113.de SO14 Top view – Multi-purpose traverse

e.g. with one additional CD channel | Without fire resistance

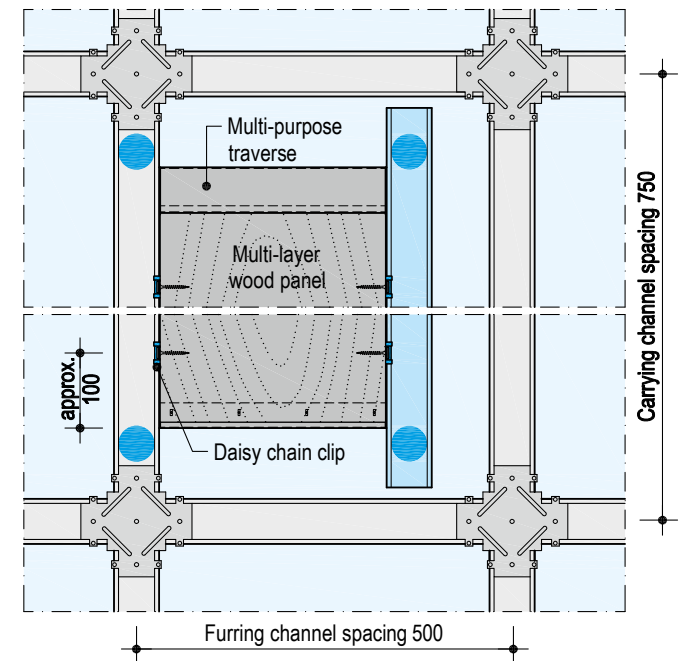

Additional grid

4 additional suspension points (e.g. Nonius suspension)



Videos for Knauf systems and products can be found under the following link:

youtube.com/knauf



The Knauf Infothek App now provides all the current information and documents from Knauf Gips KG at any time and in every location in a clear and comfortable way.

knauf.de/infothek

Knauf Direct
Technical Advisory Service:

knauf-direkt@knauf.com

www.knauf.de

Knauf Gips KG Am Bahnhof 7, 97346 Iphofen, Germany

All technical changes reserved. Only the current printed instructions are valid. The stated information represents current state-of-the-art Knauf technology. The entire state of approved engineering rules, appropriate standards, guidelines, and rules of craftsmanship are not included herewith. These and all application instructions have to be adhered to separately by the installer. Our warranty is expressly limited to our products in flawless condition. All application quantities and delivery amounts are based on empirical data that are not easily transferable to other deviating areas.

All rights reserved. All amendments, reprints and photocopies, including those of excerpts, require our expressed permission.