

KNAUF

INTRWALL[®]

*Separating and Corridor
Wall Systems for
Multi-Residential Buildings*



Build on us.

All works undertaken to prescribe the use of or to install Knauf's products and systems must be performed by experienced and, where required by applicable laws, appropriately licensed personnel. Knauf's products and systems must be installed in accordance with Knauf's installation manual, Systems+, and any other product or system specific literature issued by Knauf. If installation works are not performed in compliance with such product literature, by experienced and licensed personnel, or are incorrectly performed by experienced or licensed personnel, there is a serious risk that the works, application and performance of the relevant system or products will be compromised, which could result in property damage, injury or death.

All personnel who undertake works to install Knauf's products and systems must comply with all applicable health and safety laws, including wearing appropriate personal protection equipment. If personnel do not comply with applicable health and safety laws, including by not wearing appropriate personal protection equipment, there is a serious risk of injury or death.

All of Knauf's products and systems must only be used for the uses identified in this document (and any other product or system specific literature issued by Knauf from time to time). Before prescribing or using any Knauf product or system for any other use, you must contact Knauf. All recommended component parts for Knauf's products and systems should be used and not substituted for other products. If component parts are substituted, there is a serious risk that the works, application and performance of the relevant system or products will be compromised, which could result in property damage, injury or death.

This product manual is intended to provide general information on plasterboard products and should not be used as a substitute for professional building advice. We recommend you use a qualified person to install Knauf plasterboard. To ensure the information you are using is current, Knauf recommends you review the latest building information available on the Knauf website Knauf.com. For further information contact TecASSIST or your Knauf representative.

Content

1 GENERAL INFORMATION

Introduction	4
Description	4
Features and Benefits	5
Design Options	5
Standards	5

2 DESIGN CONSIDERATIONS

Fire Resistance	6
Fire Hazard Properties	6
Acoustics	6
Over-Partition Design	7
Wet Areas	7
Mould Resistance	7
Structural	7
Support Clips	7
Seismic	8
Structural Framing	8
Concrete Fasteners	8
Limitations	8
Construction Joints	8

3 MATERIALS

IntRwall Materials	9
Jointing and Finishing Decoration	9

4 INTRWALL SYSTEMS

IntRwall Systems	10–11
------------------	-------

5 INSTALLATION PROCEDURES

Installation Procedures	12–13
-------------------------	-------

6 INSTALLATION DETAILS

Installation Details	14–26
----------------------	-------



INTRWALL

Introduction

Knauf IntRwall is a lightweight separating wall system that offers a number of advantages compared to traditional fire-rated plasterboard systems and alternative heavyweight solutions.

IntRwall has been successfully used in a large number of apartment projects throughout Australia, including the landmark Eureka Tower in Melbourne, Raffles in Perth, Allegro in Brisbane, Elysee Residences on the Gold Coast, Bishopsgate Apartments in Newcastle and many others.

Description

Knauf IntRwall is the next generation of separating inter-tenancy and corridor wall systems designed specifically for residential apartments. Based on similar panelised Shaftliner MouldStop construction used in Knauf's PartiWall, IntRwall represents the latest advancement in lightweight fire and acoustic technology.

Shaftliner MouldStop panels are held in position by lightweight steel H-studs to form the fire barrier of the system, this can include a screw laminated layer of FireStop when using the Over-Partition Design.

The fire barrier does not require jointing or finishing. Internal linings are installed using conventional installation methods, as outlined in the Knauf Plasterboard Installation Manual.

GENERAL INFORMATION

Figure 1: Knauf IntRwall System IW60.3

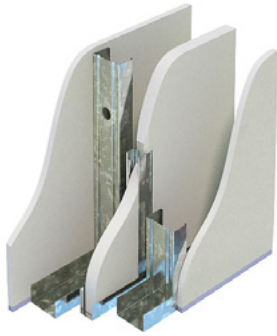

Features and Benefits

- A simple, panelised lightweight system that can be easily installed
- Lightweight system components can be manually installed without heavy lifting equipment (i.e. separating tools, hoists etc.)
- Outer linings can be terminated at ceiling level without affecting acoustic or FRL performance by following the Over-Partition design and do not require additional fire-treatment when penetrating the linings
- Services can be easily incorporated in wall cavities on one or both sides
- Services can be penetrated through the Shaftliner MouldStop barrier above the ceiling level when screw laminating additional layers of FireStop to the Shaftliner MouldStop panels

Design Options

Knauf IntRwall has been tested and assessed to meet Fire Resistance Levels (FRL) of -/60/60 and can achieve an acoustic performance of $R_w + C_{tr}$ 50 and R_w 50 as required by the National Construction Code (NCC).

IntRwall systems are available in two basic configurations:

Table 1: IntRwall System Configurations

System	Lining Configuration	FRL
IW60.3	1 x 25 mm Shaftliner MouldStop	-/60/60
IW60.4		-/60/60
IW60.5 [^]		-/60/60

[^] System IW60.5 is not covered in this manual. For system details refer to Knauf Systems+. For construction details contact TecASSIST.

Knauf IntRwall systems are available in a wide range of internal linings. These can include: water, acoustic and impact resistant plasterboard that can be applied to either side of the wall.

All construction details contained in this manual have been assessed by CSIRO.

Standards

The following Australasian Standards associated with the IntRwall systems:

- AS/NZS 2588 Gypsum plasterboard
- AS/NZS 2589 Gypsum linings – Application and finishing
- AS/NZS 1170.2 Structural Design Actions – Wind actions
- AS/NZS 1170.4 Structural Design Actions – Earthquake Actions
- AS 4055 Wind loads for housing
- AS 3999 Bulk thermal insulation – installation
- AS 1397 Steel sheet and strip – hot dipped, zinc coated or aluminium/zinc coated
- AS 3566 Self-drilling screws for the building and construction industries
- AS/NZS 4600 Cold-formed steel structures
- AS/NZS 5216 Fastenings in concrete
- AS/NZS 1530.4 Methods for fire tests on building materials
- AS/NZS 3837 Method of test for Heat and Smoke Release Rates for Materials and Products using an Oxygen Consumption Calorimeter
- AS 1191 Acoustics – Method for Laboratory Measurement of Airborne Sound Transmission Insulation of Building Elements
- AS/NZS ISO 717.1 Acoustics – Rating of Sound Insulation in Building and of Building Elements, Part 1: Airborne Sound Insulation.

DESIGN CONSIDERATIONS

Fire Resistance

IntRwall is suitable for use to meet the NCC FRL requirements for non-loadbearing corridor and intertenancy walls for Class 2 or 3 buildings of Type A or B Construction.

The IntRwall system has been fire tested and assessed by CSIRO. The performance of various system configurations has been assessed in CSIRO's assessment report FCO-3367. BRANZ has assessed Knauf Insulation to be used in IntRwall systems without affecting the established Fire Resistance Level, refer to BRANZ report FC 16109 for details. Polyester Insulation is not permitted.

As the primary fire barrier (the Shaftliner MouldStop panels) is located in the cavity between the frames, the system permits easy inclusion of services such as water and waste pipes, electrical and communications cables, as long as the primary barrier is not penetrated unless given the Certifier's approval (refer Installation Details).

The following penetrations – individually or in combinations, or back-to-back – are allowed in the outer linings and are not required to be fire-rated:

- Normal residential electrical switches and power points
- Data, communications or electrical cables passing through the linings into the cavity
- Copper, galvanized steel, or plastic water or wastewater pipes of up to 50 mm nominal diameter passing through the linings into the cavity
- Cabinets, baths, shower bases or vanities
- For other penetrations contact Knauf TecASSIST.

Fire Hazard Properties

Knauf plasterboard linings have been tested to AS/NZS 3837 – Method of Test for Heat and Smoke Release Rates for Materials and Products using an Oxygen Consumption Calorimeter. These tests were conducted in accordance with AS 5637.1 to determine their Group Number Classification, as required by NCC Specification S7C4 Fire Hazard Properties – Walls and Ceilings.

The following Knauf plasterboard linings have achieved a Group 1 classification and have an Average Specific Extinction Area of less than 250 m²/kg, making them suitable for use in buildings not fitted with a sprinkler system, in accordance with BRANZ Assessment Report FC13971:

- 25 mm Shaftliner MouldStop
- 13/16 mm FireStop
- 13 mm SHEETROCK ONE
- 13 mm WetStop
- 13 mm ImpactStop.

Acoustics

The IntRwall system has been the subject of extensive laboratory testing at the CSIRO Acoustic Laboratory at Highett, Victoria.

Acoustical opinions have been determined by Renzo Tonin and Associates Pty Ltd in opinion number RT&A TK778-21F01.

IW60.3 separating walls can satisfy NCC requirements of $R_w + C_{tr}$ equal or greater than 50 and IW60.4, IW60.5 corridor walls can satisfy NCC requirement of R_w equal or greater than 50.

Table 3: IntRwall Systems to Comply with $R_w + C_{tr}$ 50 requirements for Inter-tenancy Walls and R_w 50 requirements for Corridor Walls

System	FRL	Acoustic Performance
IW60.3	-/60/60	$R_w + C_{tr}$ 50
IW60.4/IW60.5	-/60/60	R_w 50

IntRwall satisfies NCC acoustic requirements for acoustic separation of adjoining soil and waste pipes within a cavity, providing $R_w + C_{tr}$ 40 and $R_w + C_{tr}$ 25 for services on the opposite side of Shaftliner MouldStop panels.

Figure 2: IntRwall Services Separation

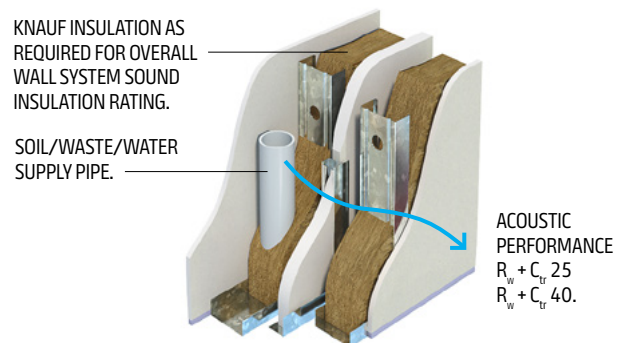

Notes

To achieve $R_w + C_{tr}$ 40 separation, insulation is required in the wall cavity on the opposite side of the pipe.

Small penetrations through outer linings in occupancy areas i.e. switches, power points, light fittings and pipes, do not need to be staggered or sealed for fire or to maintain acoustical performance. If numerous or large penetrations are required, an acoustic consultant should advise on the potential acoustic impact.

Knauf Insulation must be used within IntRwall system to achieve specified acoustic rating. Insulation thicker than the stud framing is acceptable, but is limited to the cavity size of the system.

IntRwall complies with NCC requirements for discontinuous construction.

DESIGN CONSIDERATIONS CONT.

Over-Partition Design

The Over-Partition innovation of the IntRwall system has been tested at the CSIRO for acoustic and fire performance.

Figure 3: Over-Partition IntRwall systems suitable for inter-tenancy and corridor wall systems

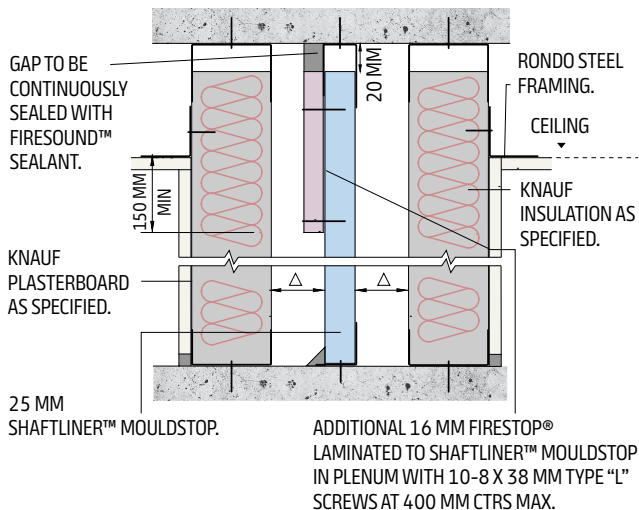

Acoustic testing was conducted on a high performance IntRwall system achieving $R_w + C_{tr}$ 55. The external linings were then stopped at the ceiling level and after adding a layer of 16 mm FireStop laminated to one side of the central Shaftliner MouldStop (to maintain the fire performance), the system was re-tested and showed no reduction in acoustic performance. Fire testing conducted for IntRwall with over-partition configuration as in Figure 3 maintained an FRL -/60/60.

Wet Areas

Water resistant wall linings must be used in areas classified as Wet Areas in accordance with the NCC. IntRwall systems are available with the following water-resistant linings on one or both sides:

- 13 mm WetStop
- 13 mm ImpactStop
- 6 mm VillaBoard fibre cement.

For installation details of Knauf Wet Area Systems refer to the Knauf Plasterboard Installation Manual. Knauf Wet Area Systems comply with the requirements of AS 3740 and is thus suitable for use in residential buildings and other buildings with a similar usage pattern.

Mould Resistance

Shaftliner MouldStop contains the added advantage of mould resistance and showed zero signs of mould growth when tested in accordance with ASTM D3273 and ASTM G21.

Structural

IntRwall systems have a maximum height of 3.0 m Shaftliner MouldStop and H studs to be full length at 0.25 kPa lateral pressure. For greater wall heights, the addition of lateral support in the form of Aluminium Wall Clips connecting H-studs to framing members at the ceiling level can be used to achieve an increased maximum height of 7.2 m.

Free standing steel studs on either side of the wall must be designed to withstand the required lateral pressure. For lateral pressures up to 0.25 kPa refer Steel Stud Walls Lined One Side in Knauf Systems+.

In high-rise apartment construction, confirmation of internal design pressures should be obtained from the project Structural Engineer, especially where there are large openings such as sliding glass doors onto balconies. Consult Knauf for stud sizes, heights and spacing for design pressures other than those specified.

Support Clips

Where required, aluminium clips on each side of the Shaftliner MouldStop central membrane at the H-stud location and be spaced at no more than 3000 mm vertically and 600 mm horizontally.

Notes

Heights of up to 7.2 m can be achieved with special detailing. Contact Knauf TecASSIST for further information.

DESIGN CONSIDERATIONS *CONT.*

Seismic

Framing components and connections must be suitably designed by Rondo in accordance with AS/NZS 1170.4 Earthquake Actions and other relevant Standards for use in seismic applications.

Structural Framing

All steel framing and components must be design by Rondo to relevant Australian Standards.

Knauf advises the use of Rondo steel framing and components in fire testing and Fire Testing Laboratory assessments of IntRwall systems.

Concrete Fasteners

Concrete fasteners to be spaced at 600 mm max centres. Fasteners must be designed by the Project Engineer in accordance with AS 5216 and all other relevant Australian Standards and provisions of the National Construction Code. Fastener manufacturer/supplier to provide compliance documentation to ensure design intent is satisfied.

Notes

Nylon anchors and drive pins are not acceptable concrete fasteners. Suitable fasteners include Rondo CERT-R-FIX or equivalent. Refer to Rondo for details.

Limitations

IntRwall systems are not suitable for use around lift shafts or in other similar applications where they may be subjected to cyclical loading.



















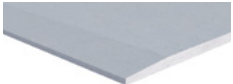

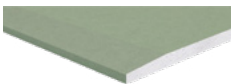



To ensure compliance with performance requirements under the NCC, it is specified that Knauf IntRwall systems are installed using the components and accessories specified and in accordance with the instructions outlined in this brochure. Material substitution may affect the performance of IntRwall systems and void the system certification.

Construction Joints

Where construction joints are necessary in IntRwall refer to Knauf Plasterboard Installation Manual or contact Knauf TecASSIST 1800 811 222 for construction details.

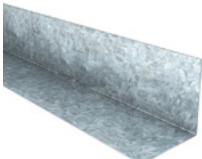
MATERIALS

Table 3: IntRwall Materials

Knauf Item Codes	Item Description	Product Image	Knauf Item Codes	Item Description	Product Image
00818588	25 mm Shaftliner MouldStop 600 x 3000 mm		00832942	6 g x 25 mm Type 'S' Steel Screws	
00818589	25 mm Shaftliner MouldStop 600 x 3600 mm		00832938	10 g x 38 mm Type 'L' Laminating Screws Pkt 500	
00817944	16 mm FireStop 1200 x 3600 mm		00832982	10 g x 16 mm Type 'D' Drill Point Wafer Head Screws	
00818593	13 mm SHEETROCK ONE 1200 x 3600 mm		00824145	CERT-R-FIX Fasteners M643	
00818643	13 mm WetStop 1200 x 3000 mm		00795248	50 mm Knauf Insulation Glasswool 11 kg/m ³ density	
00883062	13 mm ImpactStop 1200 x 3000 mm		00795250	75 mm Knauf Insulation Glasswool 11 kg/m ³ density	
00841593	IntRwall Deflection J-Track x 3000 mm		00795226	90 mm Knauf Insulation Glasswool 11 kg/m ³ density	
00824030	25 mm H-Stud x 3000 mm		00795228	90 mm Knauf Insulation Glasswool 14 kg/m ³ density	
00824031	25 mm H-Stud x 3600 mm		00820308	Knauf Firepack Mineral Wool Packer 5 m x 200 x 50 mm Pkt 3	
00757543	25 mm J-Track x 3000 mm		00820255	Sound Mastic 450 g Tube	
00817659	25 mm J-Track x 3600 mm				
00817768	35 x 35 x 0.7 mm BMT Galvanised Metal Angle x 3600 mm				
00757894	50 x 50 x 0.7 mm BMT Galvanised Metal Angle x 3600 mm				
00817836	Aluminium Clip				
00826209	Flat Aluminium Clip				

Jointing & Finishing

Knauf has a comprehensive range of jointing compounds in premixed or powder form to meet market needs and varying climatic conditions.

This manual does not provide plasterboard jointing and finishing details. Refer to Knauf Plasterboard Installation Manual or knauf.com for further information.

Decoration

Apply appropriate painting system or other decorative finishes as recommended for the required level of finish and application. Refer to Knauf Plasterboard Installation Manual.



INTRWALL SYSTEMS

Table 5: Systems IW60.3 – IntRwall Separating Walls

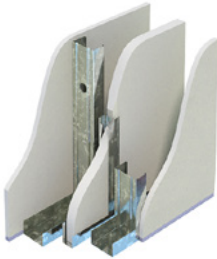
Fire Resistance Level NLB -/60/60 From both sides FRL Basis: FCO-3367	Acoustic Ratings Basis: TK778-21F01			Discontinuous Construction		
	System	Lining Side 1	Lining Side 2	Nom Wall Width (Gaps Side 1/Side 2) mm	Insulation	R _w (R _w + C _w)
 <p>System Description</p> <p>Side 1:</p> <ul style="list-style-type: none"> • Lining (refer to table) • 64 mm C-studs at 600 mm centres • Gap between C-studs and fire barrier (refer to table) • Insulation (refer to table) <p>Fire Barrier:</p> <ul style="list-style-type: none"> • 1 x 25 mm Shaftliner MouldStop between 25 mm H studs at 600 mm centres <p>Side 2:</p> <ul style="list-style-type: none"> • Lining (refer to table) • 64 mm C-studs at 600 mm centres • Gap between C-studs and fire barrier (refer to table) • Insulation (refer to table) 	IW60.3A	1 x 13 mm SHEETROCK ONE	1 x 13 mm SHEETROCK ONE	271(46/46)	KI 90G14 (both cavities)	65(50)
	IW60.3D	1 x 13 mm WetStop	1 x 13 mm WetStop	251(36/36)	KI 90G11 (both cavities)	67(52)
	IW60.3F	1 x 13 mm SHEETROCK ONE	1 x 13 mm WetStop	251(36/36)	KI 90G11 (both cavities)	66(51)
	IW60.3N	1 x 13 mm SHEETROCK ONE	1 x 6 mm Villaboard	244(36/36)	KI 90G11 (both cavities)	65(50)
	IW60.3V	1 x 13 mm ImpactStop	1 x 13 mm ImpactStop	219(20/20)	KI 75G11 (both cavities)	66(51)
	IW60.3W	1 x 13 mm ImpactStop	1 x 13 mm WetStop	239(30/30)	KI 90G11 (both cavities)	67(52)
	IW60.3X	1 x 13 mm ImpactStop	1 x 6 mm Villaboard	232(30/30)	KI 90G11 (both cavities)	67(51)
	<p>* KI 50G11 – 50 mm Knauf Insulation Glasswool 11 kg/m³ density. KI 75G11 – 75 mm Knauf Insulation Glasswool 11 kg/m³ density. KI 90G11 – 90 mm Knauf Insulation Glasswool 11 kg/m³ density.</p>					
<p>Notes Non-fire rated linings permitted to terminate at or above ceiling level for IW60.3 provided that 16 mm FireStop is laminated to Side 1 of the Shaftliner MouldStop barrier in accordance with the Knauf overpartition detail. Refer to Knauf for details.</p>						

INTRWALL SYSTEMS CONT.

Table 6: Systems IW60.4 - IntRwall Corridor Walls

Fire Resistance Level NLB -/60/60 From both sides FRL Basis: FCO-3367	Acoustic Ratings Basis: TK778-21F01					
	System	Lining Side 1	Lining Side 2	Nom Wall Width (Gaps Side 1/Side 2) mm	Insulation	$R_w(R_w + C_{tr})$
 <p>System Description</p> <p>Side 1:</p> <ul style="list-style-type: none"> • Lining (refer to table) • 64 mm C-studs at 600 mm centres • Gap between C-studs and fire barrier (refer to table) • Insulation (refer to table) <p>Fire Barrier:</p> <ul style="list-style-type: none"> • 1 x 25 mm Shaftliner MouldStop between 25 mm H studs at 600 mm centres <p>Side 2:</p> <ul style="list-style-type: none"> • Lining (refer to table) • 64 mm C-studs at 600 mm centres • Gap between C-studs and fire barrier (refer to table) • Insulation (refer to table) 	IW60.4A	1 x 13 mm SHEETROCK ONE	1 x 13 mm SHEETROCK ONE	199(20/0)	KI 50G11 (side 1 cavity)	51(37)
	IW60.4B	1 x 13 mm SHEETROCK ONE	1 x 13 mm WetStop	199(20/0)	KI 50G11 (side 1 cavity)	55(41)
	IW60.4C	1 x 13 mm SHEETROCK ONE	1 x 6 mm Villaboard	192(20/0)	KI 50G11 (side 1 cavity)	55(41)
	IW60.4J	1 x 6 mm Villaboard	1 x 6 mm Villaboard	185(20/0)	KI 50G11 (side 1 cavity)	56(43)

* KI 50G11 - 50 mm glasswool insulation 11 kg/m³.

Notes

Non-fire rated linings permitted to terminate at or above ceiling level for IW60.4 provided that 16 mm FireStop is laminated to Side 1 of the Shaftliner MouldStop barrier in accordance with the Knauf overpartition detail. Refer to Knauf for details.

INSTALLATION PROCEDURES

General Installation Notes

- Ensure that Shaftliner MouldStop panels and IntRwall H-studs are continuous and the same length prior to construction commencement. If required these can be cut to length
- 16 mm FireStop lamination to Shaftliner MouldStop panels are required for the Over-Partition installation detail only
- 16 mm FireStop and Shaftliner MouldStop panels should not be fixed to the deflection head track or base angle
- For Over-Partition design, 16 mm FireStop must be screw laminated to Shaftliner MouldStop using 10-8 x 38 mm Type "L" laminating screws at 400 mm centres in all directions and nominally 10 mm from the edges. Butt joints to fall centrally between H-studs
- Fixing sequence may be affected by existing service penetrations, refer to Knauf for details
- Penetrations requiring proprietary products must be installed in accordance with the manufacturer's specifications to ensure the fire performance is maintained



Step 1: Install Shaftliner MouldStop Framework

- Accurately align and position Base angle
- Fix Base angle, End track and IntRwall Deflection J head track to the superstructure following along the Base Angles positioning
- All fasteners to be fixed at 600 mm maximum spacing and 100 mm max from ends



Step 2: Install First Shaftliner MouldStop Panel

- Cut Shaftliner MouldStop panel to allow for 20 mm gap in IntRwall Deflection J head track
- Fit Shaftliner MouldStop panel into IntRwall Deflection J head track and push tight into End track



Step 3: Install Second Shaftliner MouldStop Panel

- Cut and fit 25 mm H-stud into IntRwall Deflection J head track, allowing for 20 mm gap
- Move tight along Base angle over the edge of Shaftliner MouldStop panel and tap lightly to provide a snug fit
- Fix 25 mm H-stud and Base Angle junction with 10 g x 16 mm Type 'D' drill point wafer head screws
- Cut second Shaftliner MouldStop panel as per Step 2 and fit into IntRwall Deflection J head track and push tight into 25 mm H-stud
- Continue to install Shaftliner MouldStop panels and 25 mm H-studs until reaching the end of the wall



Step 4: Install Final Shaftliner MouldStop Panel

- Align and fix End Angle to the end of the wall with fasteners to be fixed at 600 mm maximum spacing
- Fit final Shaftliner MouldStop panel in accordance with either installation methods shown in Figure 8 or 9
- Screw fix Shaftliner MouldStop to end angle with type 'S' screws at 400 mm maximum spacing

INSTALLATION PROCEDURES *CONT.*

General Installation Notes

- Builder/contractor to determine method of installing outer linings to suit project requirements
- Option 1: Outer linings finishing at the ceiling level OR Option 2: Outer linings to extend full height



Step 5a: OPTION 1: Over-Partition Installation - Seal Perimeter (Outer linings at ceiling level)

- Install FireStop layer continuously to one side of the Shaftliner MouldStop panels. Extending from 20 mm below the soffit above to 150 mm below the ceiling level of the wall
- Screw laminate 16 mm FireStop into the Shaftliner MouldStop using 10-8 x 40 mm Type 'L' laminating screws at max 400 mm centres (both directions) and nominal 10 mm from all edges. Plasterboard joints do not need to be set with compounds. Ensure joints are tight
- Apply continuous Firesound sealant along entire perimeter of Shaftliner MouldStop panels and FireStop lining, apply to the FireStop side of the wall only

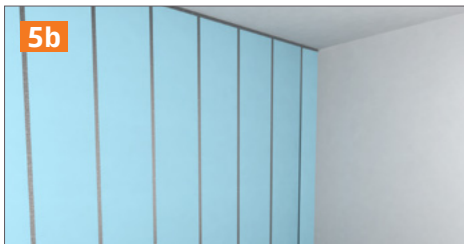

Step 5b: OPTION 2: Full-height Installation - Seal Perimeter (Outer Linings Full Height)

- Apply continuous Firesound sealant along entire perimeter of Shaftliner MouldStop panels on one side only
- As outer linings will be installed full height of wall, 16 mm FireStop in ceiling cavity is NOT necessary



Step 6: Framing Installation

- Position and install steel stud framework to both sides of the Shaftliner MouldStop panels at max 600 mm centres
- Ensure that specified cavity size for the selected IntRwall system is achieved to maintain acoustic performance and discontinuous construction (if applicable)
- Install Knauf acoustic insulation as specified

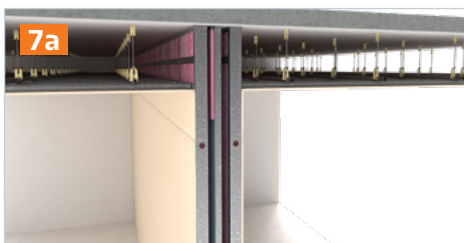

Step 7a: OPTION 1: Over-Partition Installation - Plasterboard Lining (Outer Linings at Ceiling Level)

- Knauf plasterboard outer linings may be installed to finish 100 mm above or at the ceiling height. Ensure step 5a is completed prior to installing outer linings
- Install outer non fire-rated linings as per technical literature, ensuring there is 6-10 mm gap at the base and side tracks
- Continuously fill outer lining base and side track gaps with Firesound sealant
- Finish all joints and internal and external corners with the appropriate Knauf jointing system
- Refer to Knauf Plasterboard Installation Manual and online CAD Finder for further details

INSTALLATION DETAILS

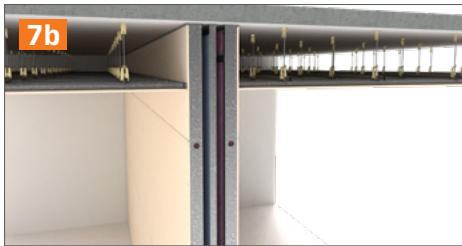

Step 7b: OPTION 2: Full-height Installation - Plasterboard Linking (Outer Linings Full Height)

- Install specified Knauf plasterboard linings to finish at the underside of slab
- Provide 20 mm gap at deflection top tracks and 6-10 mm gap at base and side tracks
- Continuously fill outer lining perimeter gaps with Firesound sealant
- Finish all joints and internal and external corners with the appropriate Knauf jointing system
- Refer to Knauf Plasterboard Installation Manual and online CAD Finder for further details

Figure 5: IntRwall Construction – Plan Detail

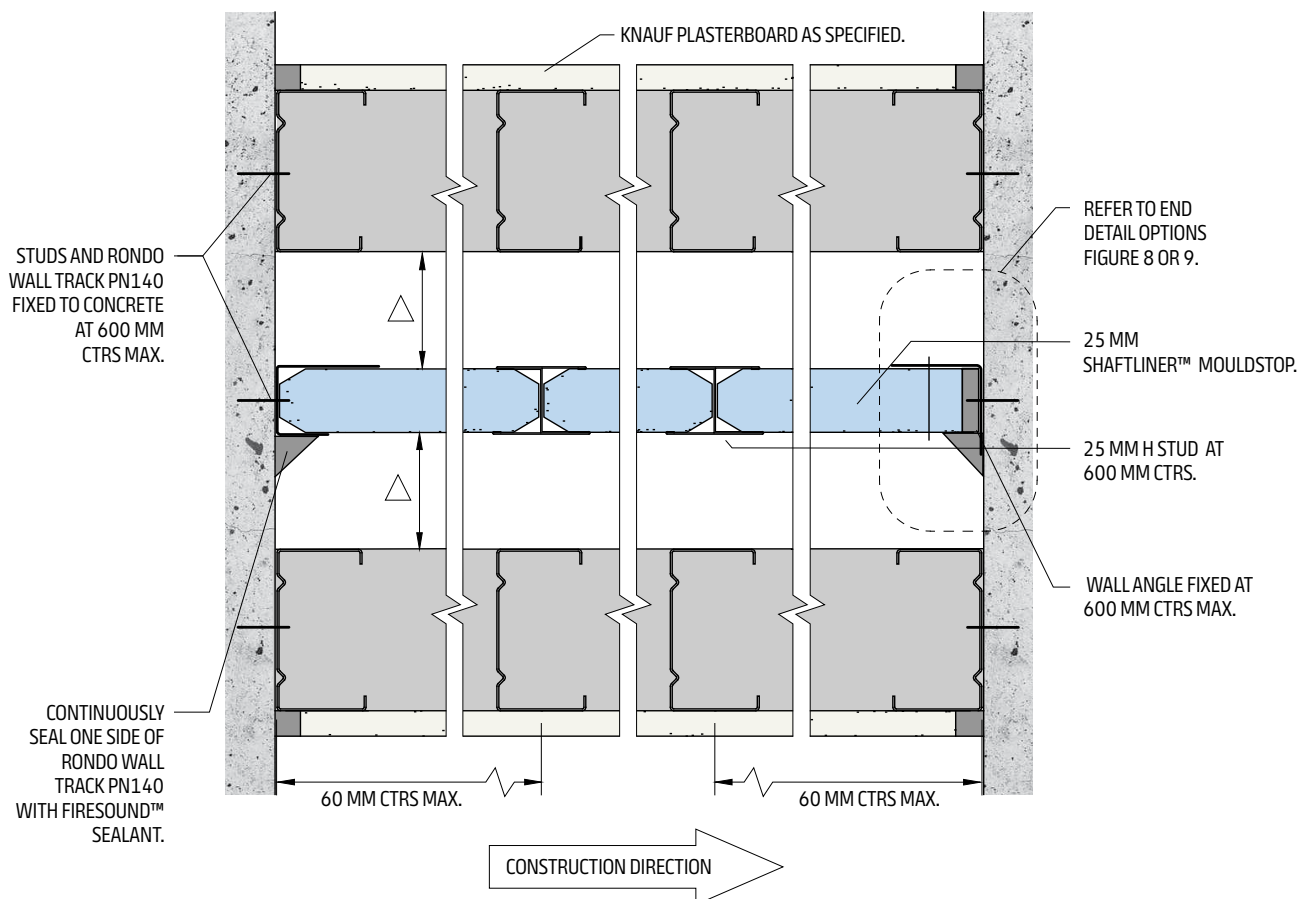

Notes

- Δ – Gap to be as per system requirement, 20 mm minimum for discontinuous construction.
- Maximum wall height is 3.6 m provided Shaftliner MouldStop and H studs are continuous and same length.

INSTALLATION DETAILS CONT.

Figure 6: Over-Partition – Section Detail

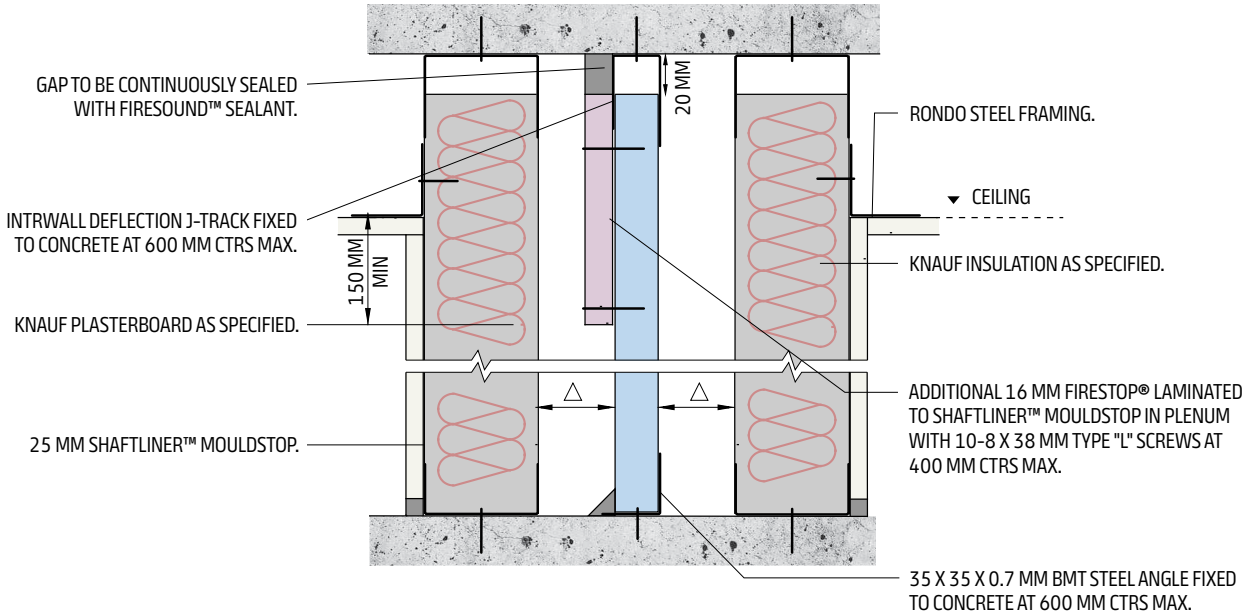
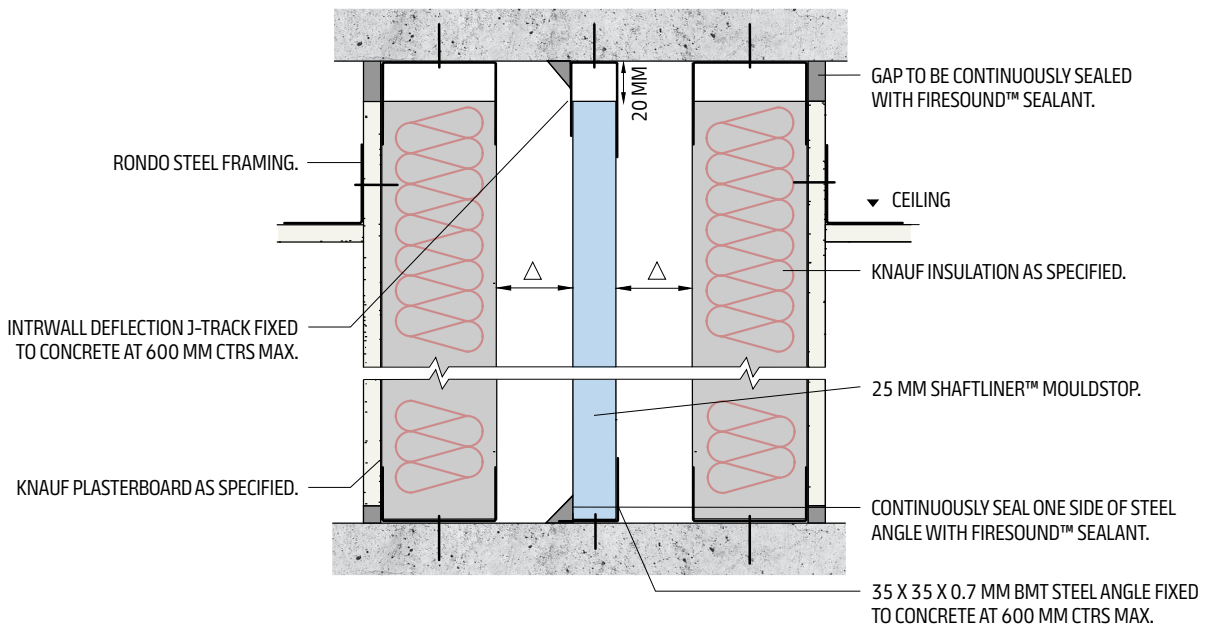

Figure 7: Full Height Internal Linings – Section Detail



Notes

- Δ – Gap to be as per system requirement, 20 mm minimum for discontinuous construction.
- Maximum wall height is 3.6 m provided Shaftliner and H studs are continuous and same length.

INSTALLATION DETAILS CONT.

Figure 8: End Panel Installation – OPTION 1 – Cutting End Panel in Half (Internal Linings Full Height)

Installation method:

- 1 Cut Shaftliner MouldStop panel into two halves, allowing for 20 mm gap in IntrWall Deflection J track, 5 mm gap between panels and trim short 5 mm on vertical edge.
- 2 Install Top panel tightly into 25 mm H-stud and raise into IntrWall Deflection J track.
- 3 Install Bottom panel tightly into 25 mm H-stud and fix into End angle with 6-18 x 40 mm wafer head type 'D' screws at max 400 mm centres.
- 4 Lower Top Panel to allow for 5 mm gap and fix into End angle with 6-18 x 40 mm wafer head type 'D' screws at max 400 mm centres.
- 5 Screw laminate 300 mm wide panel of 16 mm FireStop with 10-8 x 38 mm type 'L' screws at max 200 mm centres allowing for 6-10 mm gap at end wall.
- 6 Fully seal gap between panels and End track with Firesound sealant.

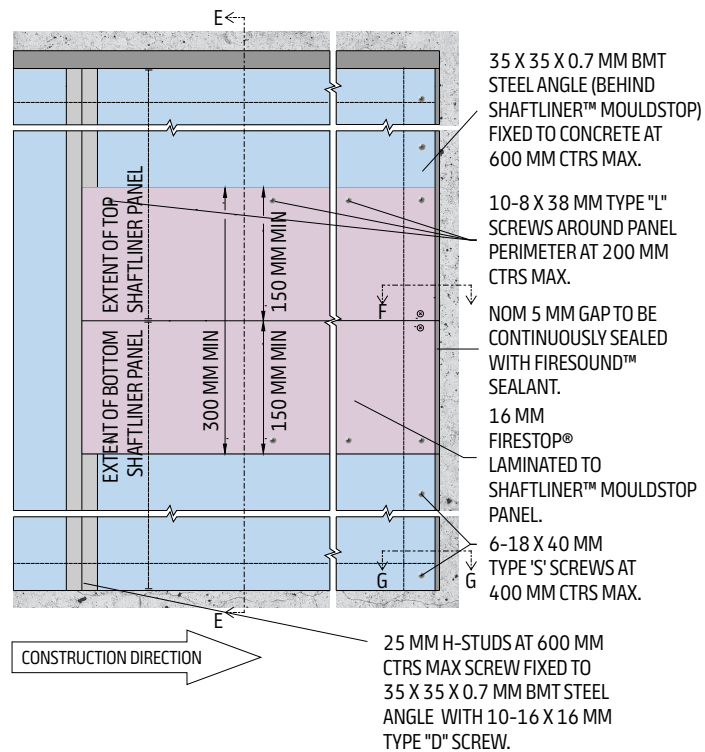

SECTION E-E

16 MM FIRESTOP® LAMINATED TO SHAFTLINER™ MOULDSTOP IN PLENUM WITH 10-8 X 38 MM TYPE "L" SCREWS AT 400 MM CTRS MAX.

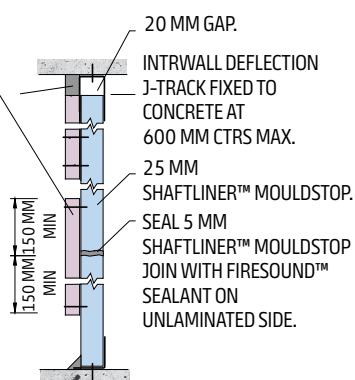

SECTION F-F

25 MM SHAFTLINER™ MOULDSTOP.

6-18 X 40 MM TYPE 'S' SCREWS AT 400 MM CTRS MAX.

SECTION G-G

NOM 5 MM GAP TO BE CONTINUOUSLY SEALED WITH FIRESOUND™ SEALANT.

25 MM SHAFTLINER™ MOULDSTOP.

INSTALLATION DETAILS CONT.

Figure 9: End Panel Installation – OPTION 2 – Trimming End Panel (Internal Linings Full Height)

Installation method:

- 1 Cut Shaftliner MouldStop panel allowing for 20 mm gap in InTRwall Deflection J track and trim short 20 mm on vertical edge.
- 3 Install Shaftliner MouldStop panel up into InTRwall Deflection J track and finish flush with the Base angle.
- 4 Push Shaftliner MouldStop panel tight into 25 mm H-Stud leaving a nominal 20 mm gap at End angle.
- 5 Screwfix Shaftliner MouldStop panel into End angle with 6-18 x 40 mm wafer head type 'D' screws at max 400 mm centres.
- 6 Fully seal gap between Shaftliner Mouldstop panel and End track with Firesound sealant.

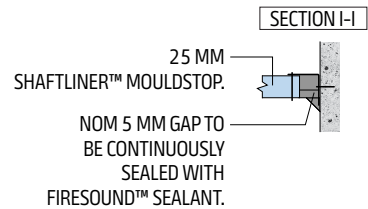
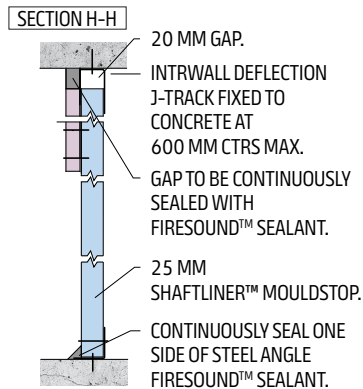
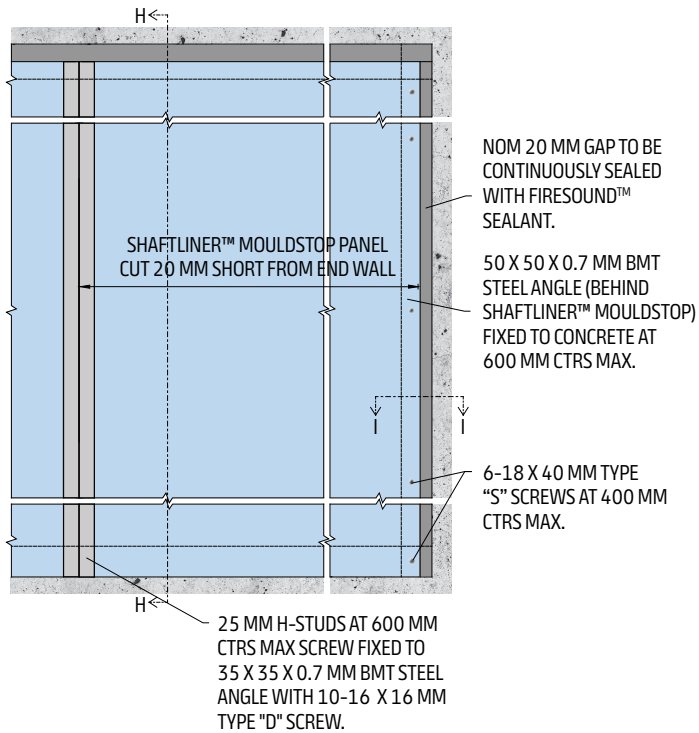

INSTALLATION DETAILS CONT.

Figure 10: Typical Corner – Plan Detail

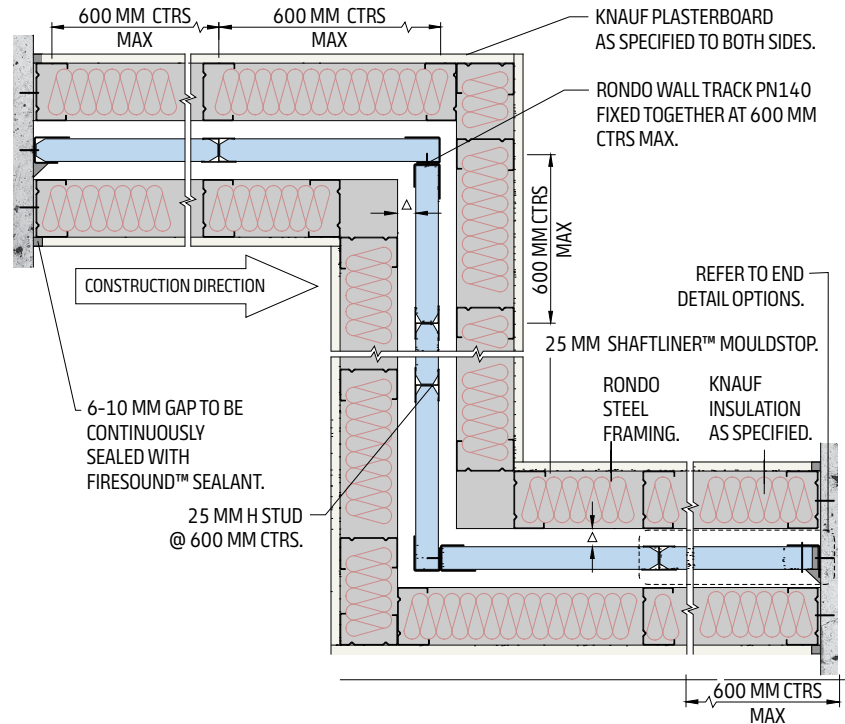
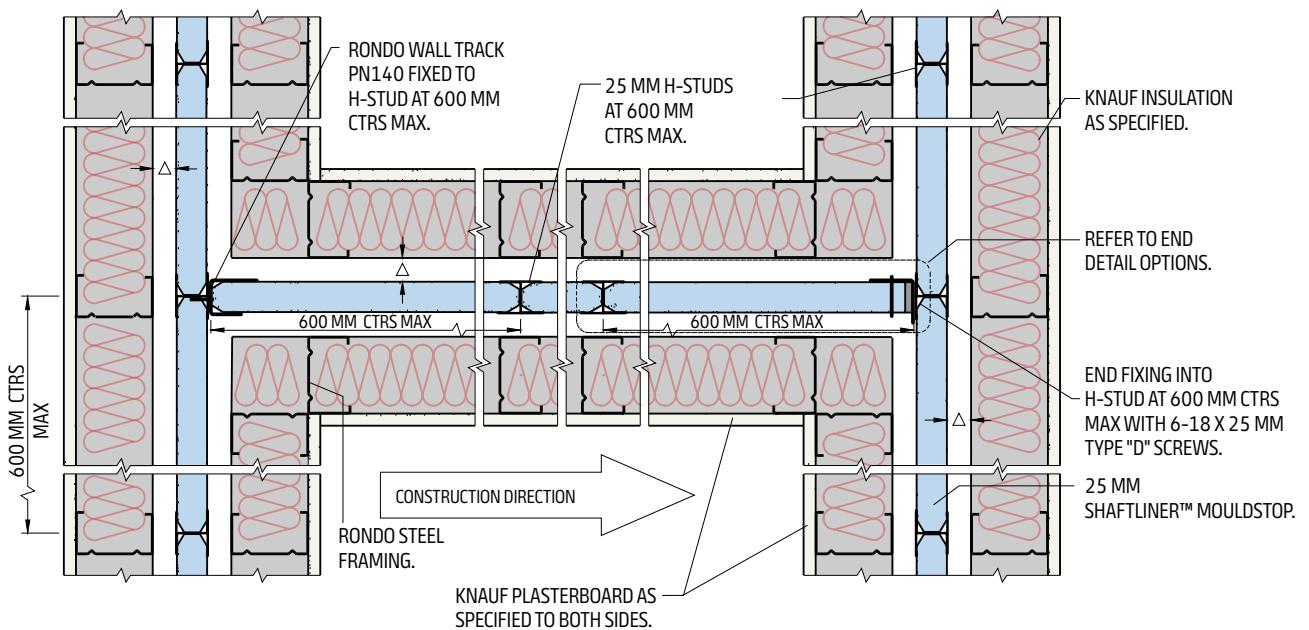

Figure 11: T-Intersection – Plan Detail



INSTALLATION DETAILS CONT.

Figure 12: Quiet Stud Junction – Plan Detail

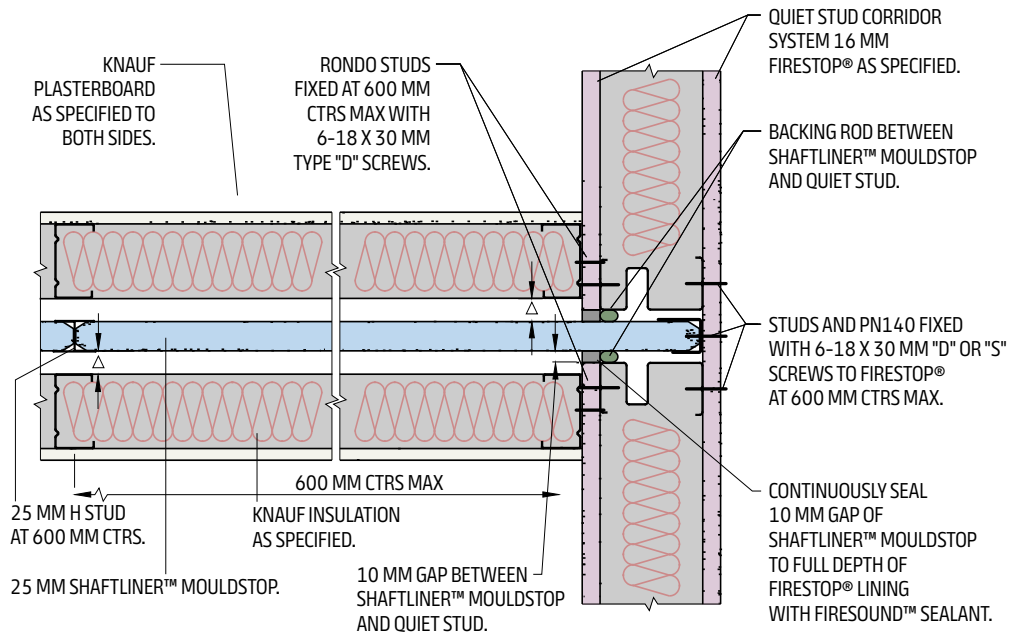

Figure 13: Control Joint – Plan Detail

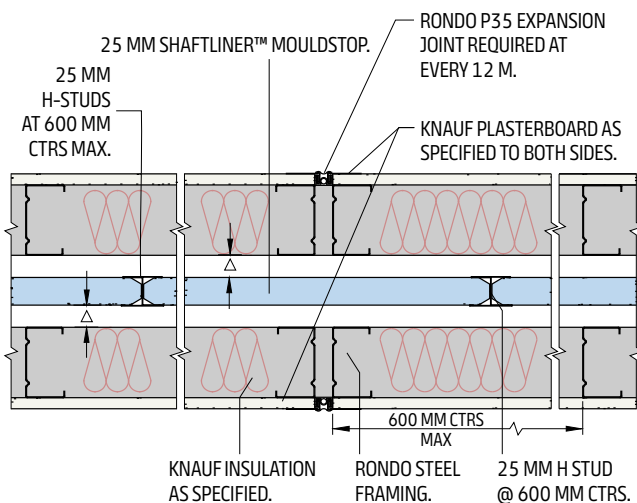
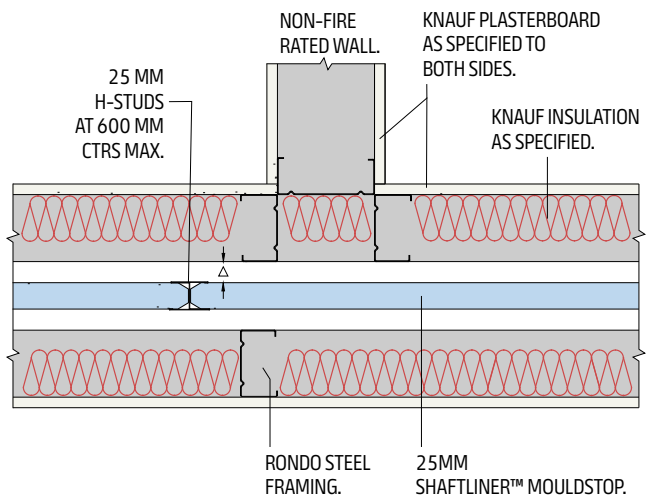

Figure 14: Internal Wall Junction – Plan Detail



Notes

Δ – Gap to be as per system requirement, 20 mm minimum for discontinuous construction.

INSTALLATION DETAILS CONT.

Figure 15: NFR External Clad Wall – Plan Detail
IntRwall FRL -/60/60 OutRwall FRL -/-/-

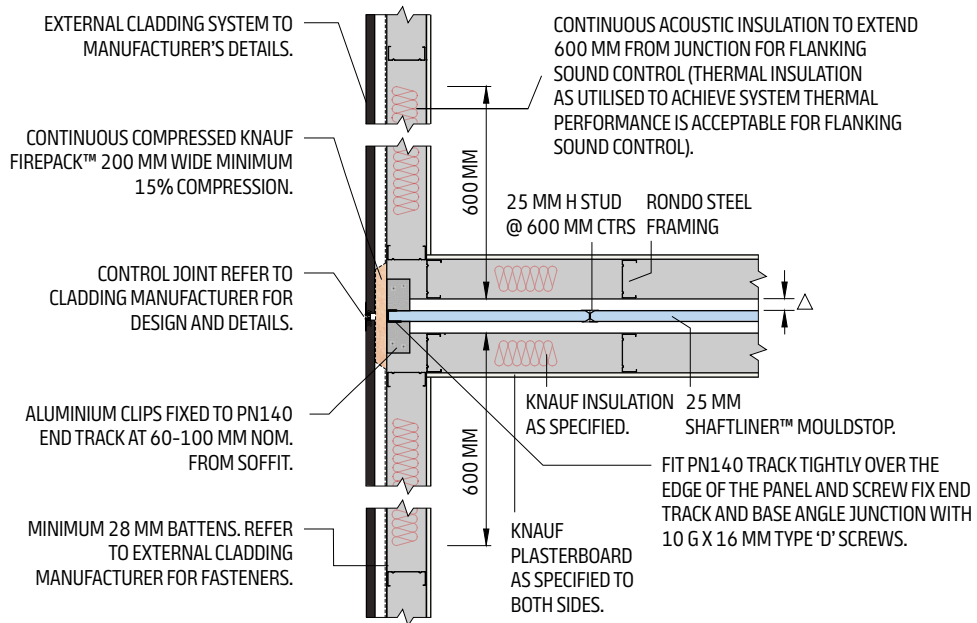

Notes

Refer to Knauf for OutRwall system design and details.

Figure 16: FR External Clad Wall – Plan Detail
IntRwall FRL -/60/60 OutRwall FRL -/60/60

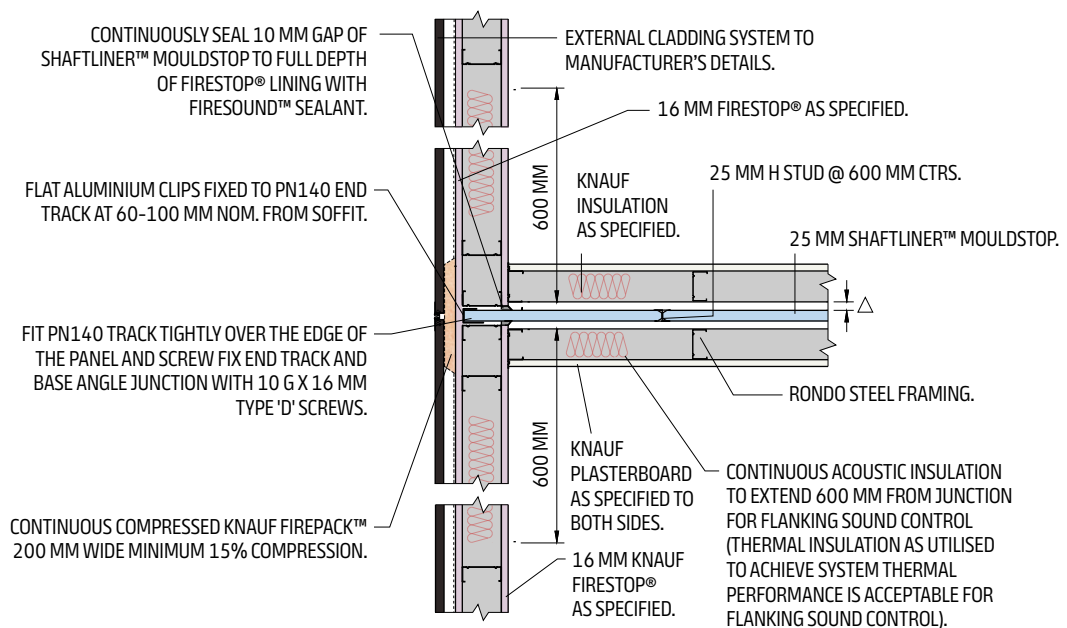

INSTALLATION DETAILS CONT.

Figure 17: Brick Veneer External Clad Wall – Section Plan

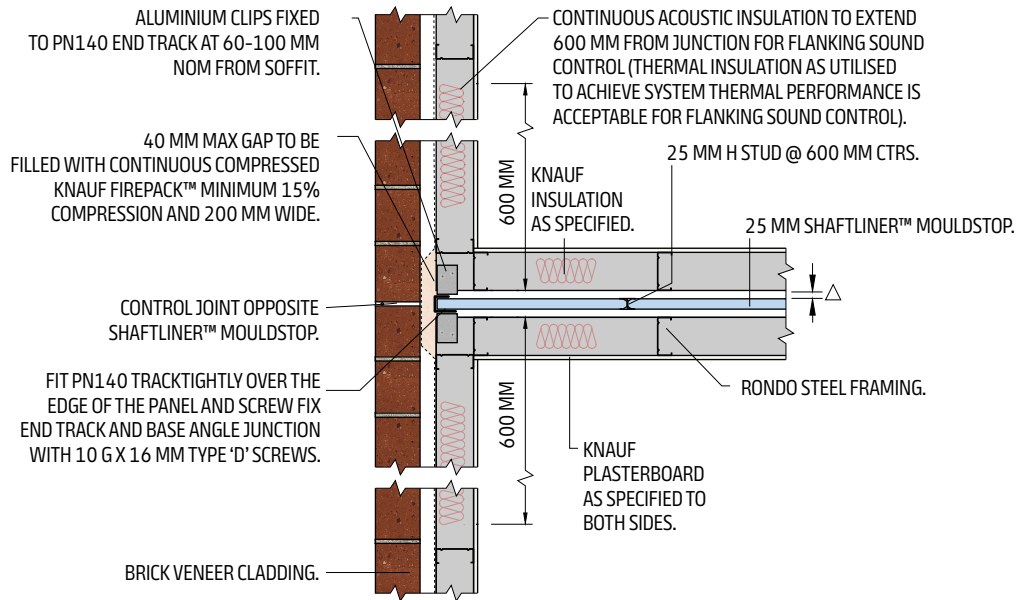
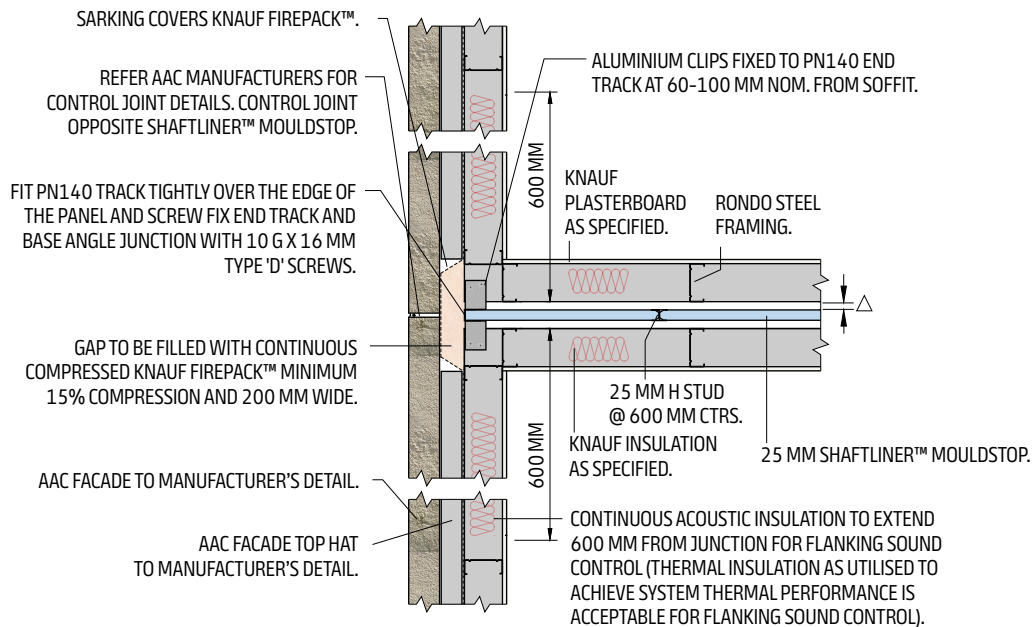

Figure 18: AAC External Clad Wall – Plan Detail



Notes

- Refer to Knauf for Brick Veneer system design and details.
- External insulation must extend min 600 mm both sides of the IntRwall and must satisfy thermal requirements.
- If no thermal insulation is required use insulation specified for IntRwall system.
- Δ – Gap to be as per system requirement, 20 mm min for discontinuous construction.

INSTALLATION DETAILS CONT.

Figure 19: Blade Column Transition – OPTION 1 – Plan Detail (Discontinuous)

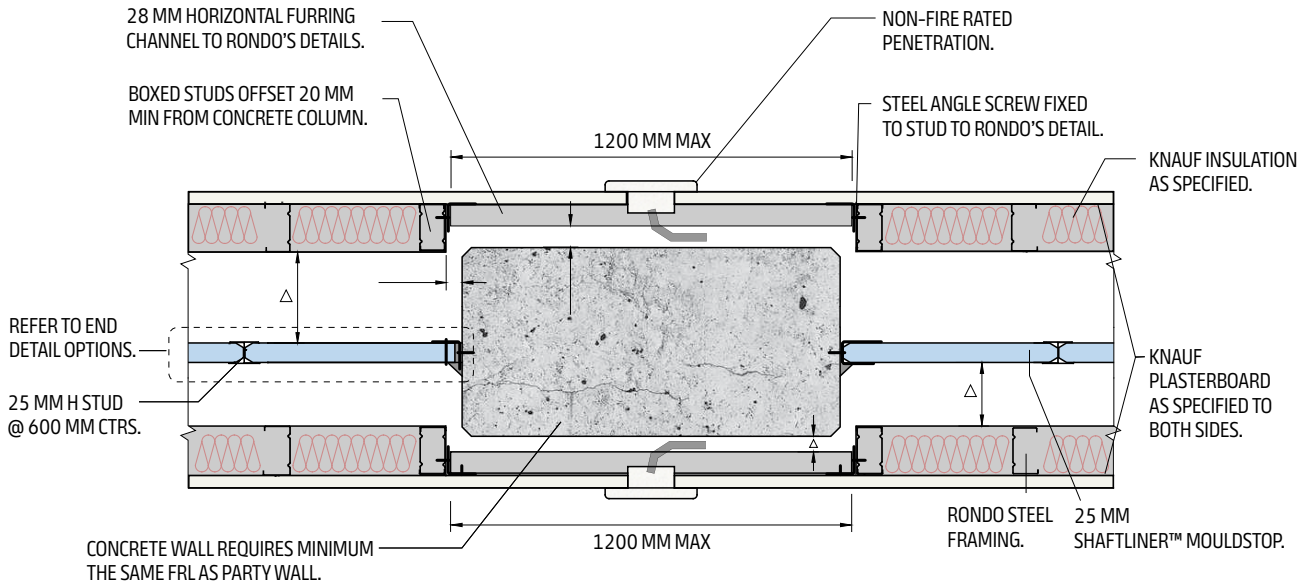
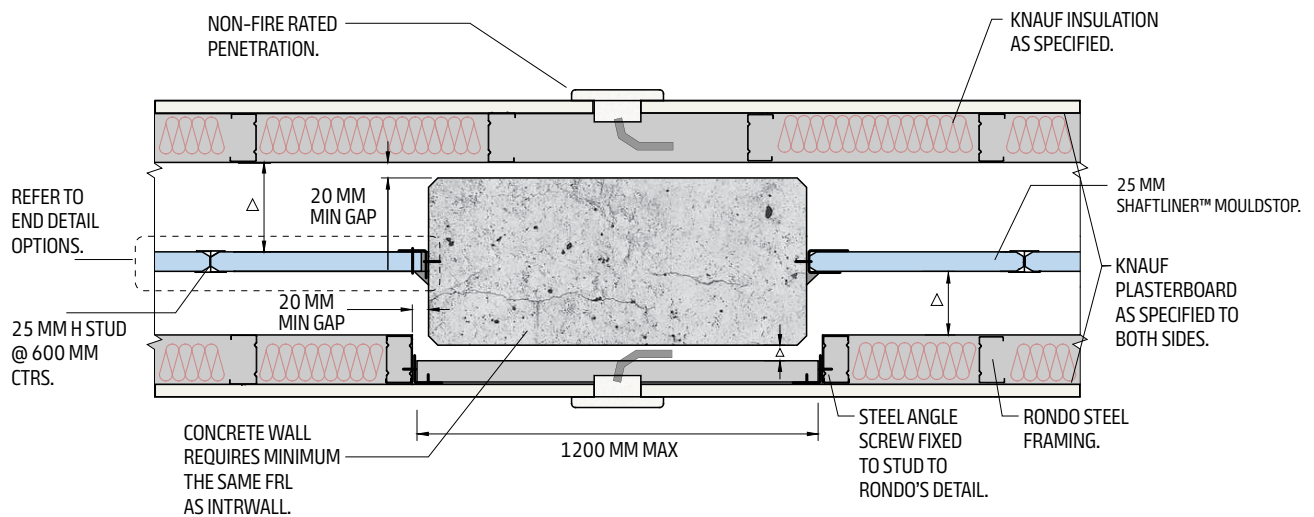

Figure 20: Blade Column Transition – OPTION 2 – Plan Detail (Discontinuous)



Notes

- Δ – Gap to be as per system requirement, 20 mm minimum for discontinuous construction.
- Blade column system to meet project specific acoustic requirements.

INSTALLATION DETAILS CONT.

Figure 21: Blade Column Transition – Plan Detail (Discontinuous/Continuous)

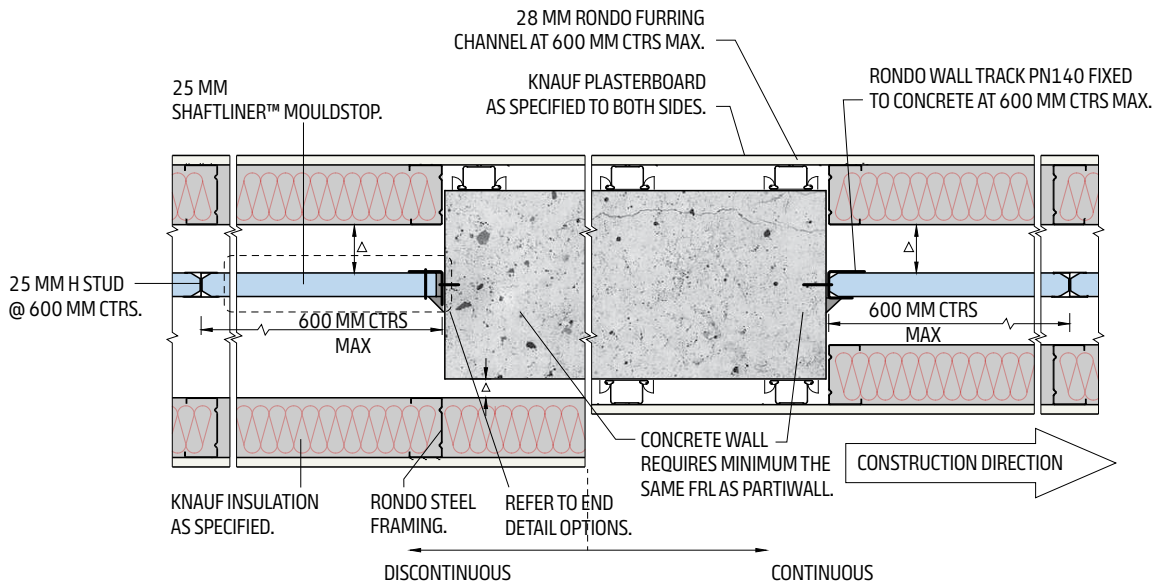
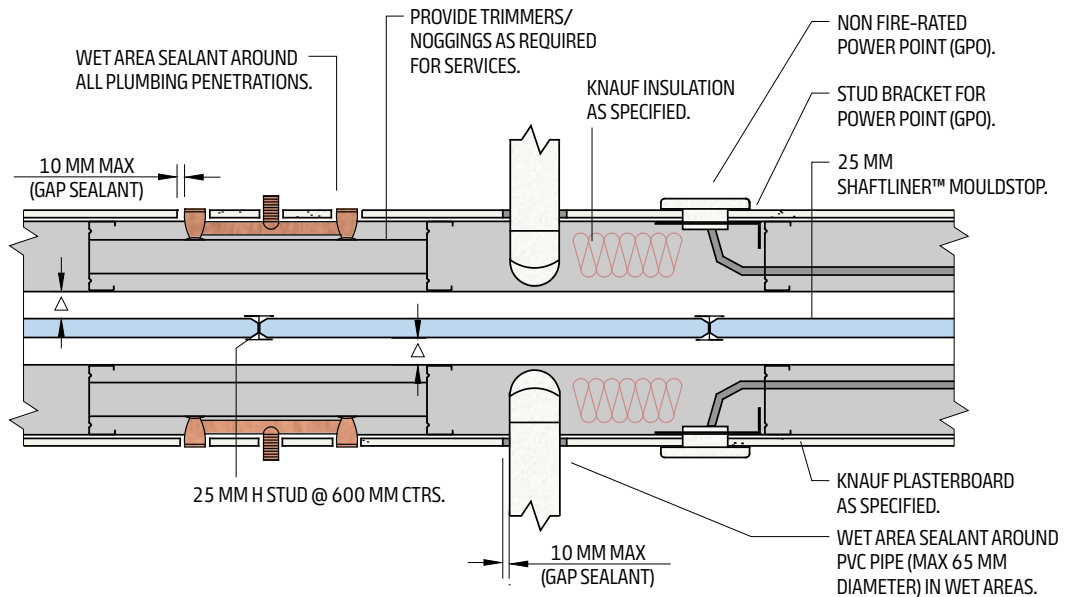

Figure 22: Non Fire-Rated Wall Penetration



Notes

- All penetrations can be back to back.
- Refer to IntRwall systems tables for insulation and wall linings.
- All penetrations must not penetrate the Shaftliner MouldStop.
- To achieve $R_w + C_w 40$ insulation is required in wall cavity on the opposite side if any soil/waste/water supply pipe.
- Δ – Gap to be as per system requirement, 20 mm min for discontinuous construction.
- Blade column system to meet project specific acoustic requirements.

INSTALLATION DETAILS CONT.

Figure 23: Metal Pipe Penetration – FRL –/60/–

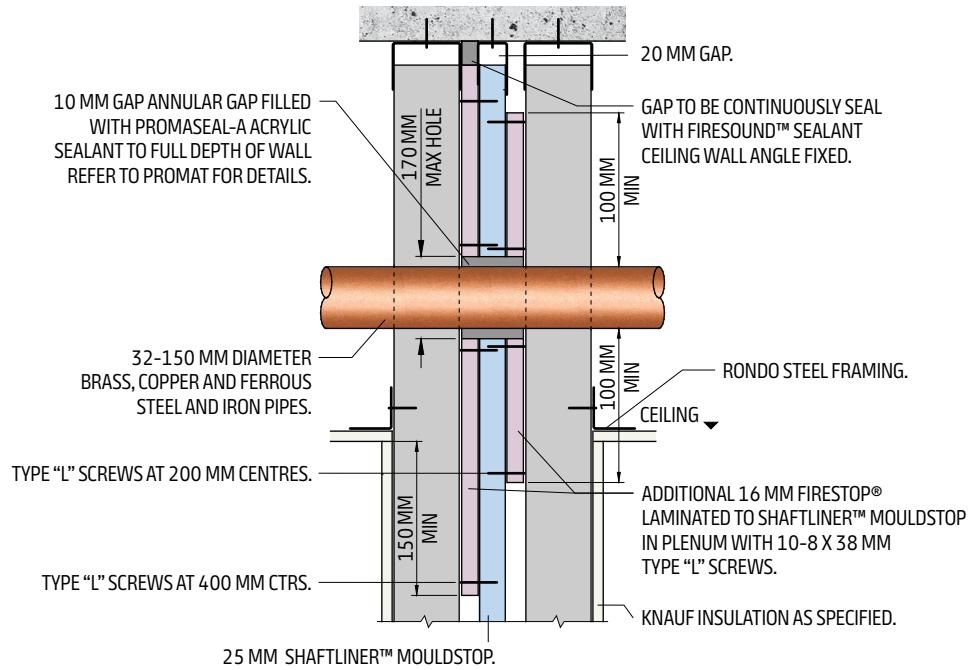

Notes

- Minimum 150 mm clearance between pipe and framing.
- Minimum 100 mm from any other combustible material or element for a distance of 2 m.
- Allow additional 20 mm in hole penetration.

Figure 24: Metal Pipe Penetration – FRL –/60/60

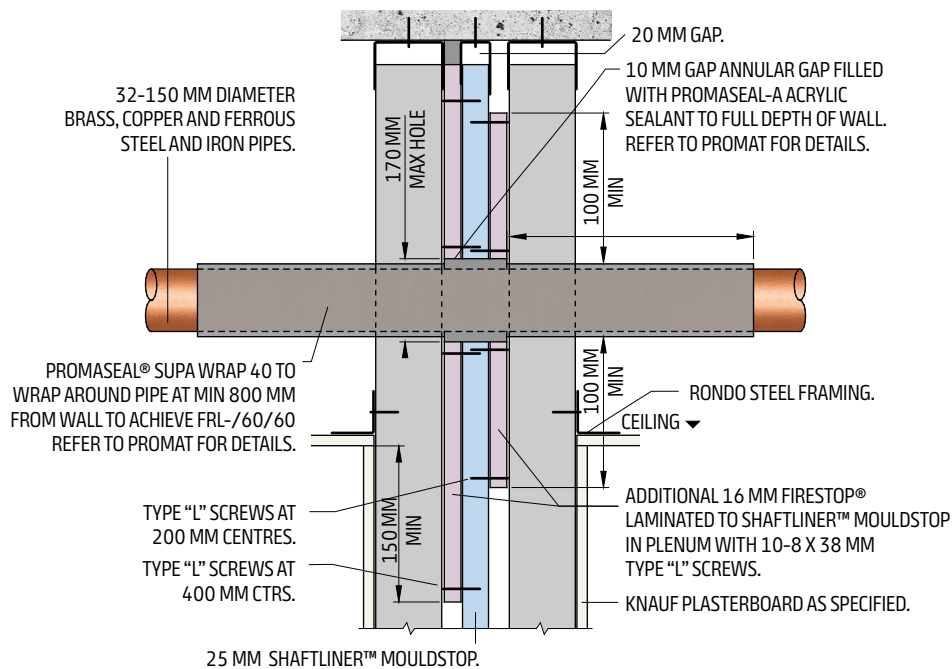

Notes

- Minimum 150 mm clearance between pipe and framing.
- Allow additional 20 mm in hole penetration.

INSTALLATION DETAILS *CONT.*

Figure 25: PE-X a Pipe Penetration – FRL -/60/60

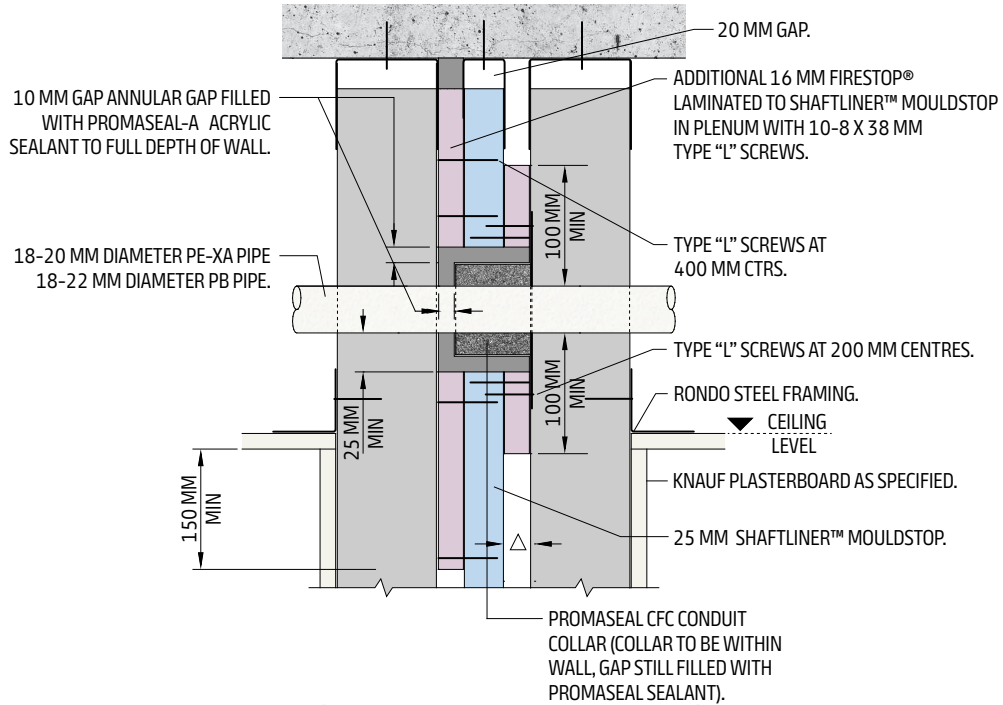
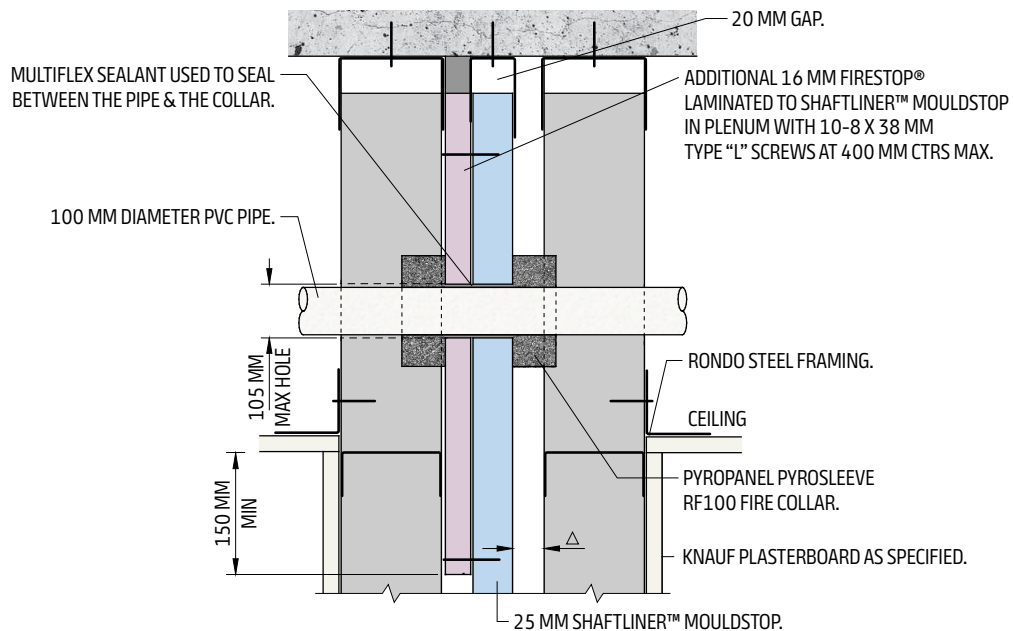

Figure 26: PVC Pipe Penetration – FRL -/60/60



Notes

- Penetrations through Shaftliner MouldStop are suitable for ceiling space only.
- Δ – Gap to be as per system requirement, 20 mm min for discontinuous construction.

INSTALLATION DETAILS *CONT.*

Figure 29: PVC Pipe Penetration – FRL -/60/60

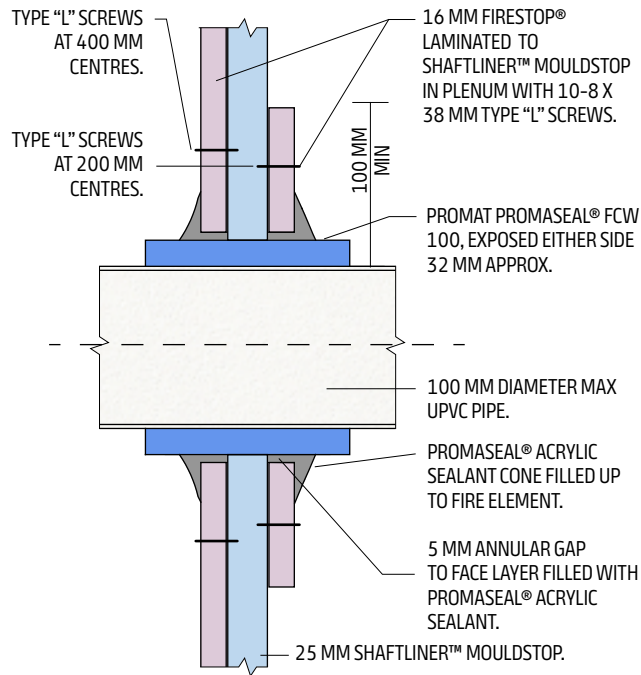
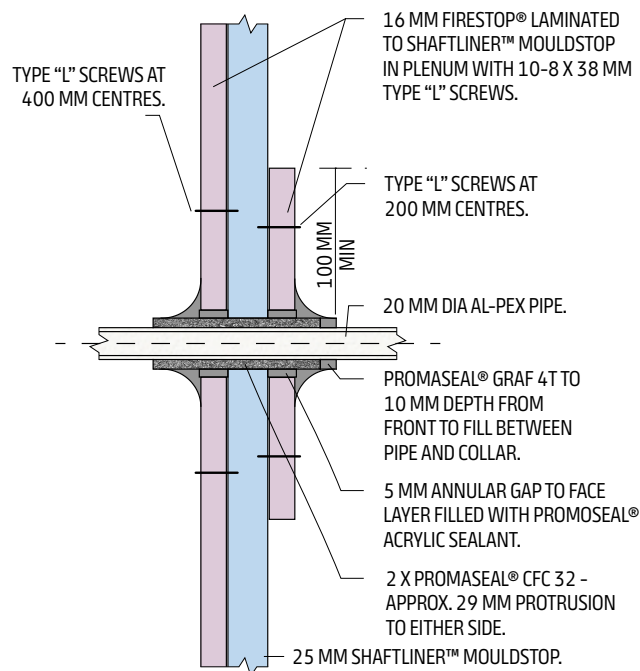

Figure 30: 20 mm PE-AL-PEX Pipe Penetration – FRL -/60/60

Notes Penetrations through Shaftliner MouldStop are suitable for ceiling space only.



INSTALLATION DETAILS CONT.

Figure 31: PB Polybutylene Pipe Penetration – FRL -/60/60

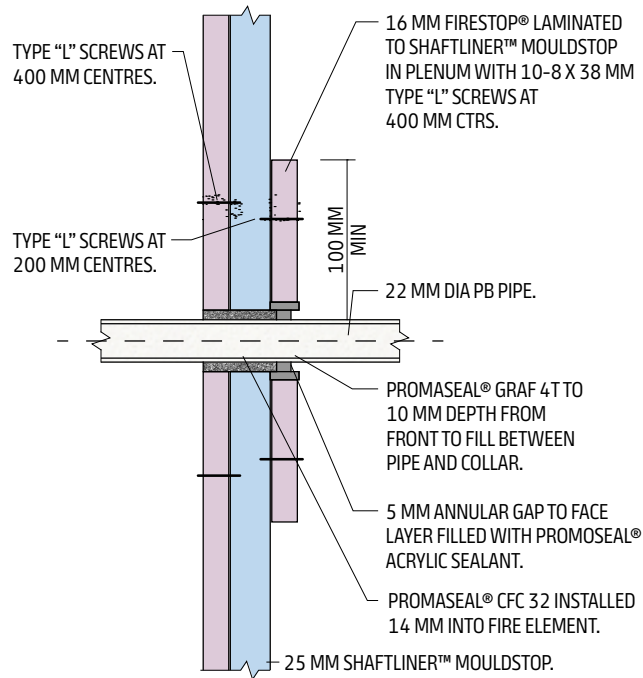
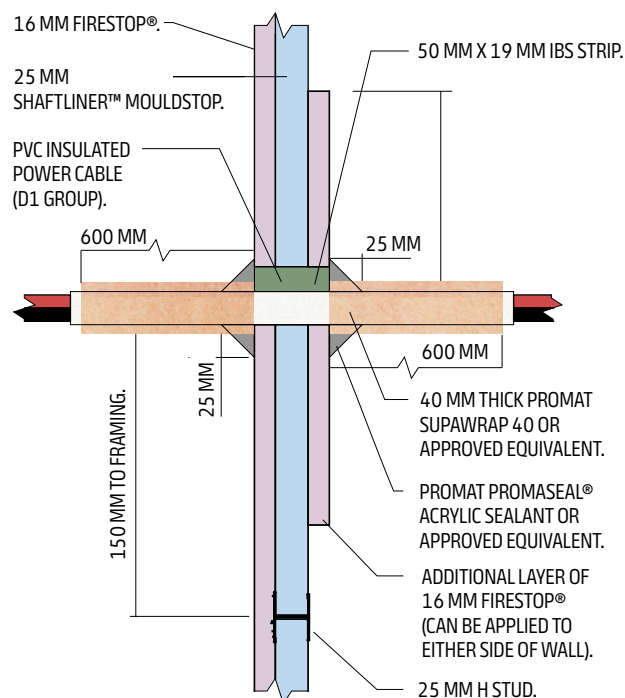

Figure 32: Power Cable Penetration at Roof Space – FRL -/60/60

Notes

Penetrations through Shaftliner MouldStop are suitable for ceiling space only.



BUILDING THE FUTURE TOGETHER.

The Knauf Group is one of the world's leading manufacturers of modern insulation materials, dry lining systems, plasters and accessories, thermal insulation composite systems, floor screed, floor systems, and construction equipment and tools. With more than 300 production facilities and sales organisations in over 90 countries, 42,000 employees worldwide, and sales of €12.6 billion, the Knauf Group is one of the largest players in the industry, with operations in Europe, the United States (US), South America, Asia, Africa, and Australia.

The Knauf Group believes that the best innovations start with a purpose; a focus on why the innovation is needed and who will benefit from it. The business's focus is to deliver innovations that help companies in the construction sector to work smarter, do more, and build better. This is achieved through investing in purposeful innovation, expanding into different markets and constantly searching for new ways to increase performance and productivity. This commitment to innovation and focus on customers is inspired by a desire to empower architects, contractors, and workers alike to improve the way societies live by changing the way buildings are designed and built. Knauf is committed to delivering only the best to its customers and partners.





Sales Enquiries

1800 003 377

To purchase Knauf plasterboard and other building materials including insulation, cornice, compounds, ceilings and accessories visit the Where To Buy page on our website for a list of Knauf Fulfilment Centres and distributors.

TecASSIST

1800 811 222

Our National TecASSIST helpline is available to answer technical questions and provide free advice to builders, contractors, architects, engineers and home owners throughout Australia.

Technical Resources

knauf.com/en-AU/tools/download-center

Find all of Knauf's technical literature in our comprehensive Download Centre. From CAD files to certifications, installation guides and data sheets - our most up to date product and system information is at your fingertips.



knauf.com

©2025 Knauf Gypsum Pty Ltd. All rights reserved. The trademarks Knauf, Build on us, TecASSIST, FireStop, Shaftliner, WetStop, ImpactStop and InTRwall are trademarks of Knauf Gypsum Pty Ltd or one or more of its affiliates, including Knauf Gips KG. SHEETROCK is a registered trademark of United States Gypsum Company and used under license. All other trademarks identified with ® or ™ are owned by third party manufacturers and not Knauf Gypsum.
Knauf Gypsum Pty Ltd. ABN 84 004 231 976. 3 Thackeray Street, Camellia NSW 2142, Australia.
29.09.2025_GVAU250819/08

**Build
on us.**