



# Lighter. Easier. Faster.

AQUAPANEL® Cement Board Indoor –  
Redefining expectations for building walls and ceilings in wetroom areas



## **AQUAPANEL® Cement Board Indoor**

Representing modern drylining technology, AQUAPANEL® is one of the leading premium cement boards, helping change the way people build, and the way buildings look and perform. Designed for interior walls and ceilings, AQUAPANEL® Cement Board Indoor is a key part of the range – enhancing the work of architects and installers alike.

It's the perfect board for exceptionally light performance, reliability and stability even in the most challenging wet and humid conditions for both wall and ceiling applications – making it ideal for everything from swimming pools and steam saunas to communal showers and kitchen areas.

Manufactured from inorganic materials and highly resistant to water and mould, AQUAPANEL® Cement Board Indoor weighs just 11 kg per square metre – making it easy to handle and fast to install, with superb flexibility for curved walls too.

Created for the next generation of imaginative, sustainable buildings, AQUAPANEL® Cement Board Indoor is changing the way the world builds.



## Contents

Features and benefits	<b>4-5</b>	Construction overview	
System overview	<b>6-9</b>	- Interior walls	<b>20-23</b>
Processing/handling	<b>11</b>	- Interior ceilings	<b>22-23</b>
Installation		Curved constructions	<b>25</b>
- Interior walls	<b>13-14</b>	Load fastening	
- Surface finishing	<b>15</b>	- Fastening loads to walls and ceilings	<b>26</b>
- Finishing options and quality levels	<b>16</b>	- Permitted console loads	<b>27</b>
- Interior ceilings	<b>17</b>	Access doors	<b>29</b>
		Technical product details	<b>31</b>

## Expectations. Redefined.

AQUAPANEL® Cement Board Indoor draws on our pioneering technology and the partnerships we build with our customers to deliver world-changing innovation in construction. By changing the way people build, we're redefining expectations for what can be achieved in wet and humid conditions – and making the whole process lighter, easier and faster.



Only 11 kg/m<sup>2</sup> for exceptionally light performance, AQUAPANEL® Cement Board Indoor saves effort in transportation and handling – while still delivering dimensional stability, reliability and best-in-class performance in the wet.



With a bending radius of 1 m, without needing to cut strips, AQUAPANEL® Cement Board Indoor provides unlimited design freedom for curved walls in everything from swimming pools to showers. Simple to score and snap, it's also easy to install.



As easy to use as gypsum board, the light cement board means faster installation, higher productivity and increased profitability at all stages of a construction project – even in the most challenging wet areas.

# AQUAPANEL® Cement Board Indoor

## Features and benefits

### AQUAPANEL® Cement Board Indoor

Aggregated Portland cement board with coated glass fibre mesh embedded in back and front surfaces. Ends are square cut, and edges reinforced and finished smoothly (EasyEdge™).

**Thickness:** 12.5 mm **Weight:** Approx. 11 kg/m<sup>2</sup>

Available dimensions			
Width (mm)	900	1200	1250
Length (mm)	1200/1250/ 2400/2500	900/2000/2400/2500/ 2600/2800/3000	900/2000/ 2500/2600



### Application fields

AQUAPANEL® Cement Board Indoor is perfect for wall and ceiling applications in wet and humid areas in a range of buildings, from sports halls and gymnasiums to schools, museums, hospitals and public buildings, as well as luxury hotels and apartments. The wide range of applications include:

- Communal/Public showers and bathroom areas
- Changing rooms
- Swimming pools and hot tubs
- Wellness areas and spa suites
- Steam saunas
- Operating theaters
- Industrial kitchens

### A host of benefits

#### Performance

- 100% water-resistant
- Mould and mildew-resistant
- Non-combustible (A1) – complies with European standards
- Robust and reliable with high impact resistance and sound insulation
- Safe to use, hygienic and manufactured from sustainable materials

#### Processing/Installation

- Only 11 kg/m<sup>2</sup> – meaning less effort in handling, including overhead installation
- Easy to cut using a simple score-and-snap technique
- No pre-drilling required
- Bending radius of 1 m at full board size

#### Finishing

- Ready keyed for tiling – only one layer required for tile finish
- Supports tiling up to 50 kg/m<sup>2</sup>
- Surface qualities up to Q4-level can be achieved

### **A reliable, robust system for wet and humid areas**

Dampness is the principal cause of structural damage. Water appears in a construction as:

- Standing and flowing water
- Capillary water
- Dripping water
- High relative air humidity

In many areas of the construction, the ability to withstand damp and water is critical for the quality and durability of a building unit, for example, in all domestic and commercial wet areas, in laboratories, kitchens, swimming pools and saunas. Protection from damp is also important in cellars and garages because these building units are often at risk from masonry damp or ground damp. Construction materials for these areas must meet a variety of requirements and display the following characteristics:

- Water resistance and dimensional stability of the material
- Resistance to mould formation
- Moisture vapour permeability for optimum indoor climate

AQUAPANEL® Cement Board Indoor is the ideal building panel for such areas. AQUAPANEL® Cement Board Indoor is water-resistant. Under water impact, AQUAPANEL® Cement Board Indoor displays extremely slight and system-safe changes in form. The cement board changes neither its structural cohesion nor its static characteristics. AQUAPANEL® Cement Board Indoor is resistant to mould growth and is therefore also suitable for use in areas where there is a high level of damp. Altogether, this robustness, resistance and reliability in performance makes AQUAPANEL® Cement Board Indoor perfect for both walls and ceilings in wet environments.

## Certifications of AQUAPANEL® Cement Board Indoor

### **CE Marking**



AQUAPANEL® Cement Board Indoor complies with EN 12467 Class 2.

### **Safe and hygienic solution**

AQUAPANEL® Cement Board Indoor is 100% water-resistant and completely inorganic, so there is no risk of mould or mildew. They meet the highest requirements for a safe and hygienic environment inside the building – as certified by the German Building Biological Institute Rosenheim (IBR).



### **Impact resistance**

AQUAPANEL® Cement Board Indoor have been tested for impact resistance. They have been officially certified by the Materials Testing Institute, University of Stuttgart (MPA) as having the rigidity and strength to withstand heavy ball impact.



# System overview

## Accessories

### Fastening

#### AQUAPANEL® Maxi Screws



AQUAPANEL® Maxi Screws have been specially developed for fixing AQUAPANEL® Cement Board onto timber and metal frameworks of differing thicknesses. Needlepoint and drillpoint versions with countersink are available.

All AQUAPANEL® Maxi Screws have a special corrosion-proof coating, which provides a guaranteed 720 hours' corrosion resistance in a salt spray test.

#### Packaging:

SN 25: 1000 pieces/carton

SB 25: 250 pieces/carton

SN 39: 500 pieces/carton

SB 39: 250 pieces/carton

SN 55: 250 pieces/carton

Collated screws available on request.

	Timber framework		Metal framework				
	Single layer	Double layer	Metal thickness 0.6-0.7 mm			Metal thickness 0.8-2.0 mm	
			Single layer	Double layer	Triple layer	Single layer	Double layer
AQUAPANEL® Maxi Screw SN 25			x				
AQUAPANEL® Maxi Screw SB 25						x	
AQUAPANEL® Maxi Screw SN 39	x		x	x			
AQUAPANEL® Maxi Screw SB 39						x	x
AQUAPANEL® Maxi Screw SN 55		x			x		

### Joint treatment and surface finishing

#### AQUAPANEL® Joint Adhesive (PU)



AQUAPANEL® Joint Adhesive (PU) is used for wall applications to bond individual AQUAPANEL® Cement Board Indoor panels.

#### Coverage:

Approx. 50 ml/m<sup>2</sup> (approx. 25 ml/m joint)

Cartridge contents sufficient for:

Approx. 6.5 m<sup>2</sup> (panel size 900 x 1250 mm)

Approx. 10 m<sup>2</sup> (panel size 1250 x 2000 mm;  
1250 x 2600 mm)

#### Packaging:

310 ml/cartridge

20 cartridges/carton

#### AQUAPANEL® Joint Filler & Skim Coating – white



AQUAPANEL® Joint Filler & Skim Coating – white is a cement-bound filling material for full-surface skim coating on AQUAPANEL® Cement Board, for example before the application of a decorative plaster or paint finish. AQUAPANEL® Reinforcing Mesh must be embedded.

AQUAPANEL® Joint Filler & Skim Coating – white can be also used for filling joints between panels.

AQUAPANEL® Tape (10 cm) must be embedded.

#### Coverage:

Approx. 0.7 kg/m<sup>2</sup>/mm coating depth

#### Packaging:

20 kg/bag

**Note:** Machine processing is possible with PFT RiTMO (230 V) (A3-2L pump unit, SWiNG sprayer, LK 402 air compressor).

---

### AQUAPANEL® Tape (10 cm)

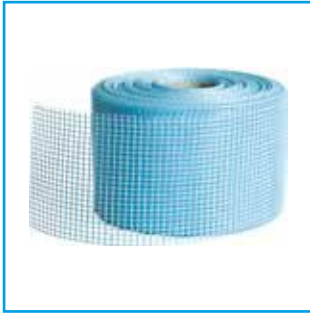

AQUAPANEL® Tape (10 cm) is a glass fibre tape with an alkali-resistant coating. It is used to reinforce joints.

Must be embedded in AQUAPANEL® Joint Filler & Skim Coating – white.

**Coverage:**

Approx. 2.1 m/m<sup>2</sup>

**Packaging:**

10 cm wide roll, 20 m long

18 rolls/carton

10 cm wide roll, 50 m long

12 rolls/carton

---

### AQUAPANEL® Reinforcing Mesh



AQUAPANEL® Reinforcing Mesh is a glass fibre fabric used to reinforce AQUAPANEL® Joint Filler & Skim Coating – white.

**Coverage:**

Approx. 1.1 m/m<sup>2</sup>

**Packaging:**

100 cm wide roll, 50 m long

30 rolls/pallet

---

### AQUAPANEL® Q4 Finish



AQUAPANEL® Q4 Finish is a ready-to-use and water-repellent skim coat for high-quality finely finished surfaces up to Q4 standard. For application above the tiled area or as an all-over skim coating over AQUAPANEL® Joint Filler & Skim Coating – white with AQUAPANEL® Reinforcing Mesh.

**Coverage:**

Approx. 1.7 kg/m<sup>2</sup>/mm coating depth

**Packaging:**

20 kg/pail

**Note:** For joint reinforcement, use Knauf glass fibre cover strips.

# System overview

## Accessories

### Priming

#### AQUAPANEL® Board Primer



AQUAPANEL® Board Primer is a ready-to-use synthetic dispersion for priming AQUAPANEL® Cement Board Indoor panels to provide maximum adhesion of tiles and plasters.

**Coverage:**  
Approx. 40-60 g/m<sup>2</sup>

**Dilution:**  
1:2 with water

**Packaging:**  
15 l/pail  
2.5 l/pail

### Additional accessories

#### AQUAPANEL® Traverse\*



AQUAPANEL® Traverses are used for fitting wall-mounted loads up to 1.5 kN/m (e.g. mounting bolts, shelving, handrails) onto drylining walls made with AQUAPANEL® Cement Board Indoor panelling. They are resistant to alkalis and moisture and are available with (MH type) or without (M type) timber insert.

**Axis frame dimensions:**  
600/625 mm

**Height:**  
Approx. 290 mm

**Plate thickness:**  
0.75 mm with special corrosion protection layer

**M type:**  
Without impregnated timber insert

**MH type:**  
With core-impregnated MDF filler, approx. 18 mm thick

\* Not suitable for ceiling application.

#### AQUAPANEL® Access Doors



AQUAPANEL® Access Doors can be installed in partition and plumbing walls built with AQUAPANEL® Cement Board Indoor. They are easy to install and safe to handle.

**Type 1:**  
AQUAPANEL® Access Door  
Splash Water Protection

**Type 2:**  
AQUAPANEL® Access Door  
Humid Rooms

**Sizes:**  
300 mm x 300 mm  
400 mm x 400 mm  
500 mm x 500 mm  
600 mm x 600 mm

Please indicate application details when ordering.

# System overview

## System solution

### System solution

A technologically advanced building system that perfectly integrates with the whole range of Knauf products and accessories, AQUAPANEL® Cement Board Indoor has been designed to be the ultimate installation solution for wetrooms and other wet or humid areas. Its performance in the wet, as well as its flexible joint treatment options, make it ideal for both walls and ceilings.

### Interior wall

Robust, impact resistant and 100% water-resistant for reliable performance. For wall applications, single and double planking are possible, depending on the fire protection and sound insulation demands of each project. See construction overview (p.20-23) for details.



#### Example of wall build-up

- |   |                                   |
|---|-----------------------------------|
| 1. Knauf CW corrosion-resistant metal profile | 5. AQUAPANEL® Joint Adhesive (PU) |
| 2. Knauf insulation materials                 | 6. AQUAPANEL® Board Primer        |
| 3. AQUAPANEL® Cement Board Indoor             | 7. Flexible tile adhesive         |
| 4. AQUAPANEL® Maxi Screw                      | 8. Tiles                          |
- Other surface options are possible (p.15-16)

### Interior ceiling

Suitable for indoor areas of high humidity including wet rooms. As in wall applications, AQUAPANEL® Cement Board Indoor can use single or double planking for ceilings, depending on fire and sound requirements. See construction overview (p.22-23) for details.

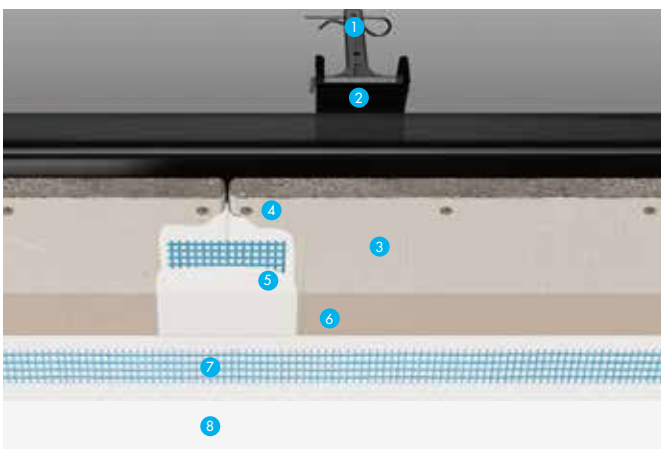

#### Example of ceiling build-up

- |   |   |
|---|---|
| 1. Nonious Hanger Bottom  | 6. AQUAPANEL® Board Primer  |
| 2. Knauf CD60/27 corrosion-resistant metal profile                                    | 7. AQUAPANEL® Joint Filler & Skim Coating – white and AQUAPANEL® Reinforcing Mesh |
| 3. AQUAPANEL® Cement Board Indoor   | 8. Paint  |
| 4. AQUAPANEL® Maxi Screw  | Other surface options are possible (p.15-16)                                      |
| 5. AQUAPANEL® Tape (10 cm) embedded in AQUAPANEL® Joint Filler & Skim Coating – white |   |

## 100% water-resistant

Superb for swimming pools

- Effortlessly handles splash, spray and even the highest humidity with no expansion or warping.
- Eliminates humidity and thermal-related expansion, which could otherwise cause tiles to crack or loosen.
- Compatible with acoustic ceiling plaster to absorb noise – perfect for swimming pools.



# Processing/handling

## Transporting, storing and formatting boards

### Transporting and storing

Always carry the boards upright, or use board rollers. Handle with fork lift or crane as palletted goods. Take care not to damage corners and edges when setting the boards down! Place boards down on their long edge before laying them flat.

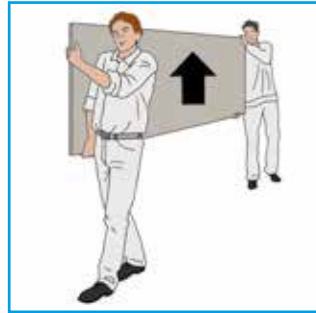

Use a pallet to support the boards when using mechanical handling equipment. Ensure that the base is strong enough to support the boards.

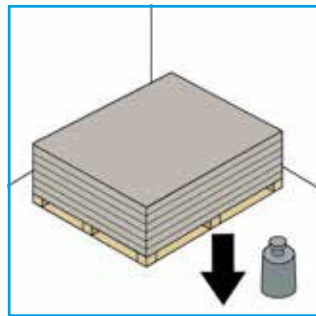

Store boards horizontal and flat. Protect boards from moisture and weathering before they are installed. Boards which have become damp must be dried on both sides on a flat surface prior to fitting.

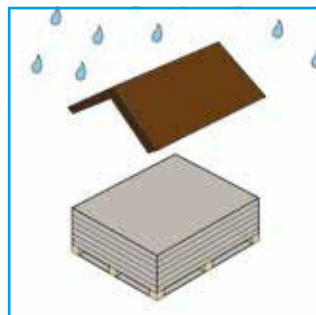

Before installing, condition the boards to the ambient temperature and humidity. The ambient air and component temperatures may not be below +5°C. Do not apply joint fillers, skim coat or finishing materials in temperatures less than +5°C.

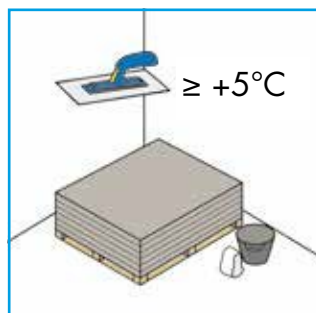

### Formatting

Mark the desired shape or opening on the board with pencil and ruler. Use a knife to score the board on one side along the line so that the mesh is cut. Snap the scored edge and cut the mesh on the rear side. Smooth any rough areas caused by scoring with a rasp.

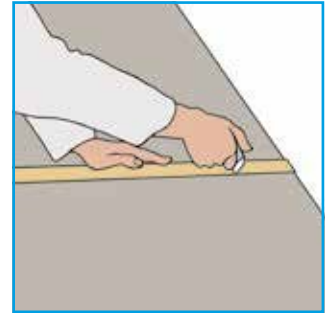

For sharp-edged cuts, for example, exterior edges, use a hand-held circular saw with a dust extractor or a pendulum jigsaw. Use of a carbide or diamond-tipped saw blade is recommended.



To make cut-outs for wiring and pipes, use a jigsaw or keyhole saw. The diameter of the opening should be approximately 10 mm greater than the diameter of the pipe. The remaining gap can be closed with a cuff, suitable sealant or sealing strip.

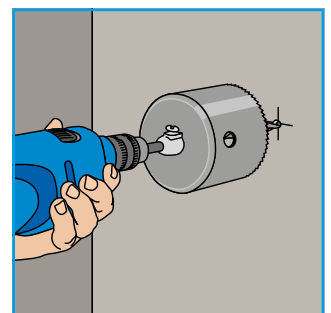
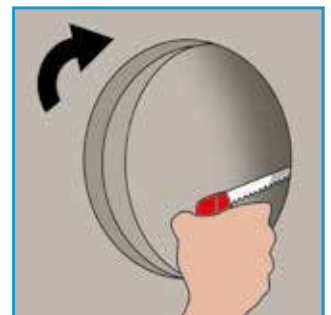

## Clean and safe

The perfect recipe in food processing

- 100% water-resistant – making it perfect for walls that need intensive cleaning and high-pressure jet spraying.
- Even with intense cleaning with chemical agents, AQUAPANEL® Cement Board Indoor will not soften, swell, crumble or disintegrate.
- Inorganic, and so will never harbour microbes, mould or mildew.
- Offers superior fire resistance – ideal for a range of applications and environments.



# Installation

## Installation of interior walls

### 1. Create substructure and align the board

The connection profile on either side must be coated with partition wall putty or sealing tape. Rotary pin dowels or other fasteners are used to secure the profiles to the walls.

For best results, use lightweight Knauf metal studs. This will ensure accuracy and that they will not move or twist due to shrinkage or water ingress. Set studs at a maximum 625 (600) mm for horizontal and vertical installation. Timber studs can also be used.

#### Align the board

Align the first AQUAPANEL® Cement Board Indoor panel along the profiles using a water level.

In addition to horizontal mounting, vertical mounting is also possible with all AQUAPANEL® Cement Board Indoor panels.

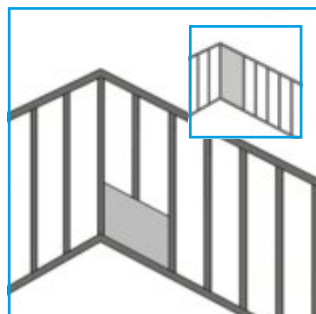

### 2. Fastening with screws

Fasten AQUAPANEL® Cement Board Indoor to the framework with AQUAPANEL® Maxi Screws. First fasten the screws into the centre of the cement boards; then work towards the ends and the edges. During installation, make sure the boards are resting on the framework.

Screw spacing  $\leq 250$  mm.  
Distance from edge  $\geq 15$  mm.

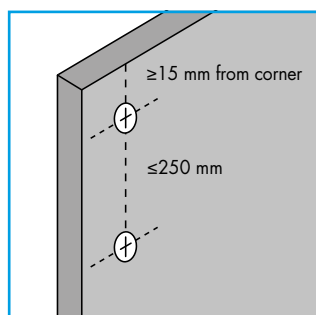
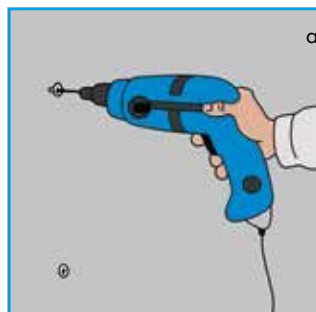

### 3. Place next board

#### Option 1:

##### Horizontal installation

Install the next AQUAPANEL® Cement Board Indoor panel and ensure that the boards are correctly aligned horizontally and vertically. Screw panel to the framework. When fitting subsequent rows of boards, ensure that the vertical joints are offset by a minimum of one stud cavity.

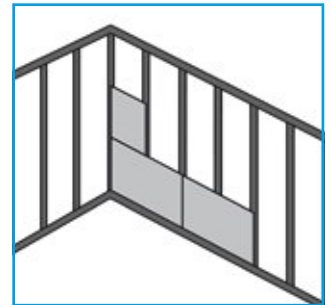

#### Option 2:

##### Vertical installation

Depending on the room height, additional boards must be placed vertically. In this case make sure they are aligned correctly and the added board height is at least 400 mm. Insert the AQUAPANEL® Cement Board Indoor into the bed of the adhesive and screw the panel to the framework. Joint reinforcement of the AQUAPANEL® Cement Board Indoor panel is achieved by means of the adhesion technique.

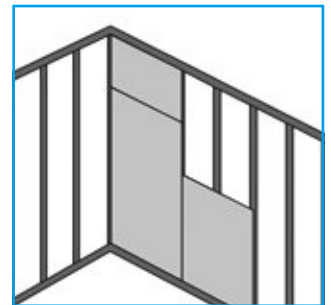

### Special notes

As preparation for joint treatment with AQUAPANEL® Joint Filler & Skim Coating – white, leave a gap of 3-5 mm between boards using a suitable spacer.



# Installation

## Installation of interior walls

### 4. Joint treatment

#### Option 1: AQUAPANEL® Joint Adhesive (PU)

In order to ensure good connection with AQUAPANEL® Joint Adhesive (PU), clean the edges of the board using, for example, a wet brush. Apply AQUAPANEL® Joint Adhesive (PU) before the next board is placed. Leave the adhesive to harden, after which the excess AQUAPANEL® Joint Adhesive (PU) can be scraped off (usually the next day). The joints between the walls, ceiling and floor require permanent elastic sealing in dry areas. Expansion joints should be at minimum of 7.5 (7.2) m intervals.

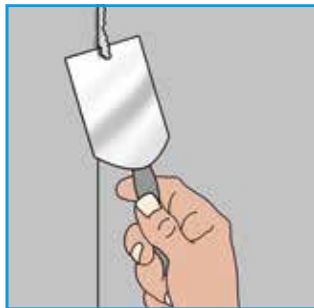
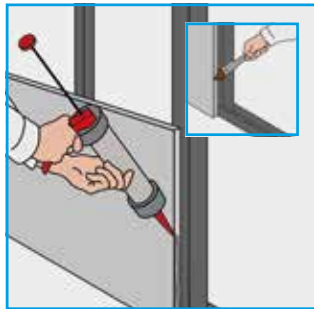

#### Option 2: AQUAPANEL® Joint Filler & Skim Coating – white and AQUAPANEL® Tape (10 cm)

All joints should be filled with AQUAPANEL® Joint Filler & Skim Coating – white, and then embed AQUAPANEL® Tape (10 cm) centred over all joints. Apply a thin layer of AQUAPANEL® Joint Filler & Skim Coating – white to cover the tape. Expansion joints should be at a minimum of 15 m intervals.

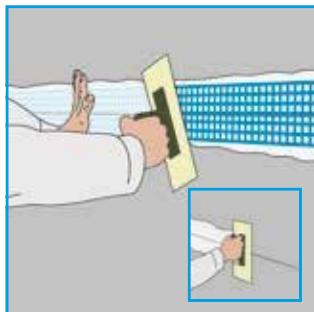

### 5. Horizontal multi-layer planking (optional)

For multi-layer planking, all horizontal and vertical panel joints must be offset. Vertical joints by a minimum of one stud cavity, horizontal joints by at least 300 mm. For double-sided double-layer constructions the panel joints of the facing boards also have to be offset. The first layer of multi-layer planking can be mounted with butt-joint boards (without adhesive) and fixed with 6 screws/m<sup>2</sup>.

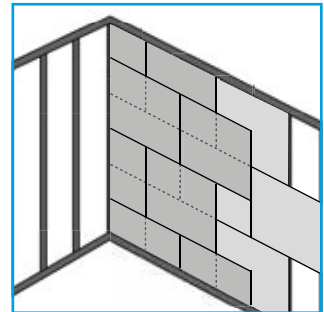

### 6. Vertical multi-layer planking (optional)

For multi-layer planking, all lateral panel joints must be offset by one stud cavity. Horizontal panel joints, which result from possible addition of boards in the vertical dimension, have to be mounted with an offset of minimum 300 mm. For double-sided double-layer constructions the panel joints of the facing boards also have to be offset. The first layer of multi-layer planking can be mounted with butt-joint boards (without adhesive) and fixed with 6 screws/m<sup>2</sup>.

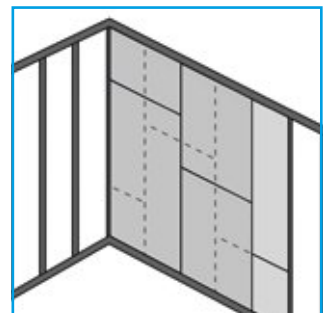

### 7. Priming

AQUAPANEL® Cement Board Indoor must be primed before tiling or finishing, using AQUAPANEL® Board Primer (primer/water 1:2).

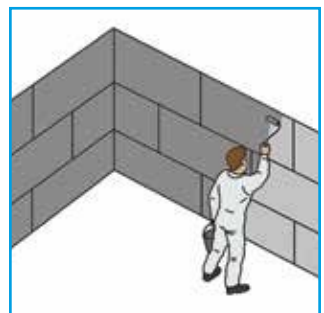

# Installation

## Surface finishing of interior walls

### Tiling

For ceramic tile coverings, (tile dimensions  $\leq 600$  mm x 600 mm), use a flexible adhesive when placing tiles. The tile adhesive must – as a minimum – meet the requirements of class C2 according to EN 12004. Tile weight: 50 kg/m<sup>2</sup> (for bigger tile sizes and heavier tiles, further measures apply).



### Skim coating

AQUAPANEL® Cement Board Indoor can be prepared for painting by applying AQUAPANEL® Joint Filler & Skim Coating – white to the full surface (minimum coating depth 4 mm).

AQUAPANEL® Reinforcing Mesh must be applied and embedded in AQUAPANEL® Joint Filler & Skim Coating – white. To achieve a finish level of Q2 apply another thin layer of AQUAPANEL® Joint Filler & Skim Coating – white and smooth out the full surface. When dry, the surface can be painted.

Most common painting systems can be used. These include water-based emulsions, matt enamels, polymer resin paints, and epoxy-based enamels. For surface finishes up to Q4 quality, apply AQUAPANEL® Q4 Finish over the entire pre-prepared (filled and reinforced) surface.

**Note:** A full range of other surface finishing options are also possible with AQUAPANEL® Cement Board Indoor, from clean room coatings to acoustic plasters – making it ideal for any wetroom environment.

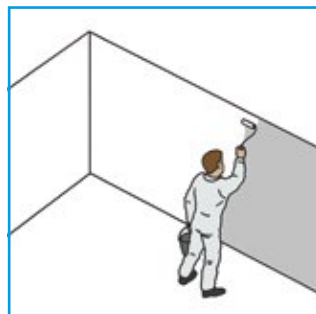
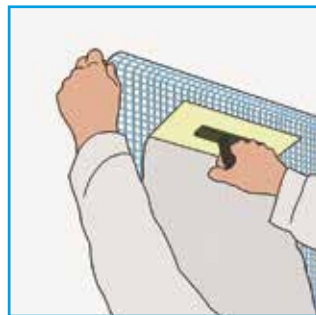

### Coating above the tiled section up to Q4 quality

Using a wide stainless steel finishing trowel, apply AQUAPANEL® Q4 Finish to the visible joints that have been bonded with AQUAPANEL® Joint Adhesive (PU). Embed the glass fibre joint cover strips into the centre of the paste so that they overlap the joints. Apply a thin layer of AQUAPANEL® Q4 Finish to the cover strips. Remove excess material. Fill the screw heads with AQUAPANEL® Q4 Finish. If necessary, after drying, use a hand sander to remove irregularities from the screw holes.

Sand away all surface unevenness. Apply AQUAPANEL® Q4 Finish to a width of at least 20 cm (5 cm beyond the edge of the first layer). Embed fastener heads and sand down any uneven areas. Apply AQUAPANEL® Q4 Finish to completely cover the untiled areas using a finishing trowel. Apply the filler solidly to fill in uneven areas in the joints and smooth the surface texture.

If necessary, sand down with paper. If a Q4 surface quality is required, apply a further layer of AQUAPANEL® Q4 Finish. After approx. 24 hours' drying, sand with abrasive paper (grade 120 or finer). For particularly smooth surfaces, sand down with, for example, an electric orbital sander.

### Coating

Depending on intended uses and requirements, water-based emulsion paints, silicate emulsion paints or latex paints can be used.

**Note:** The tiled section of the wall should be > 50% of the total height of the wall. Not suitable for areas subject to water spray.

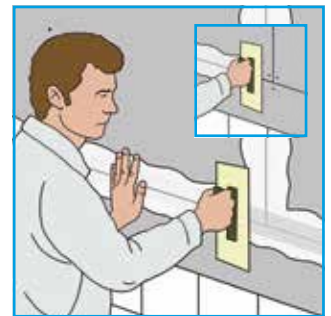

# Installation

## Finishing options and quality levels of interior walls

### Surface finishing and quality levels

AQUAPANEL® Cement Board Indoor can be used with every conceivable surface finish, while it is possible to achieve four quality levels when closing joints. Supporting tiling of up to 50 kg/m<sup>2</sup>, it also provides greater flexibility and options for finishing, adding value to the build while easing installation for contractors.

Level of finishing	Q1	Q2 (Standard)	Q3	Q4
	Jointed surface	Smooth surface for <u>normal</u> optical requirements	Smooth surface for <u>higher</u> visual requirements	Smooth surface for <u>high</u> visual requirements
Aesthetic requirements	None	Normal. Traces and trowel marks possible.	Enhanced. Few marks and traces under direct light. Shading is still possible under shallow light angles.	High end. Minimised appearance of any marks or traces. Shading caused by shallow light angles will be avoided to a large extent.
Application requirements	<p><b>Option 1:</b> Joint treatment with AQUAPANEL® Adhesive (PU). Joints scraped off (following day). All screw heads filled with AQUAPANEL® Joint Filler &amp; Skim Coating – white.</p> <p><b>Option 2:</b> Joint treatment with AQUAPANEL® Joint Filler &amp; Skim Coating – white and AQUAPANEL® Tape (10 cm). All screw heads filled with AQUAPANEL® Joint Filler &amp; Skim Coating – white.</p>	<p><u>Following Q1 treatment:</u></p> <p>Full coating with AQUAPANEL® Joint Filler &amp; Skim Coating – white with embedded AQUAPANEL® Reinforcing Mesh, followed by a thin layer AQUAPANEL® Joint Filler &amp; Skim Coating – white to cover the mesh. Imperfections and trowel marks smoothed out.</p>	<p><u>Following Q2 treatment:</u></p> <p>Apply an additional thin layer of AQUAPANEL® Joint Filler &amp; Skim Coating – white. Surface sanded (grade 120 or finer).</p>	<p><u>Following Q3 treatment:</u></p> <p>Fully coating with an additional layer AQUAPANEL® Q4 Finish. Re-finish with an electric orbital sander (grade 120 or finer).</p>
Finished surface suitability	Only suitable for functional applications such as stability, fire resistance and sound insulation. Medium and coarse-structured paint coatings.	Medium and coarse-structured wall coverings, matt filling, medium and coarse-structured paint coatings/coats, top coats (particle size/largest particle over 1 mm).	Fine-structured wall coverings, matt, fine-structured paint coatings/coats, top coats (largest particle size less than 1 mm).	Smooth or glossy wall coverings, e.g. metal-based or vinyl wallpapers, scumbles, paints or coats up to medium gloss, stucco marble or similar specialist decorative finishes.
<b>Note:</b> AQUAPANEL® Cement Board Indoor must be primed before tiling or finishing				



# Installation

## Installation of interior ceilings

### Fixing

Align the first AQUAPANEL® Cement Board Indoor panel carefully, perpendicular to the supporting profile. Screw the panel to the framework using AQUAPANEL® Maxi Screws (material requirement 25 pcs/m<sup>2</sup>). The centre space between the supporting profiles is 300/312.5 mm.

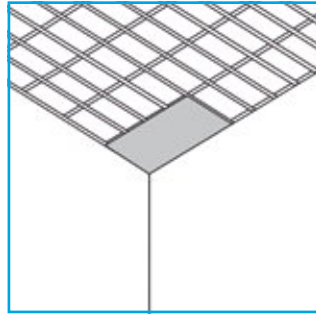

Leave a gap between joints of at least 3-4 mm. Make sure all joints are staggered. After installation, joints should be filled in with AQUAPANEL® Joint Filler & Skim Coating – white, with 10 cm AQUAPANEL® Tape embedded into the filler. Fill all screw heads.

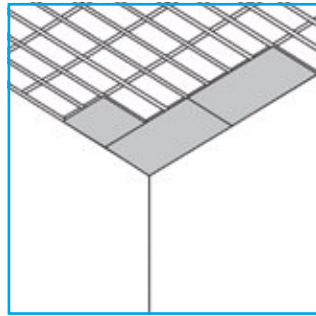

### Priming

Prime the surface over using AQUAPANEL® Board Primer (primer/water 1:2).



### Surface finishing

Use AQUAPANEL® Joint Filler & Skim Coating – white to coat the panels to at least 4 mm depth all over, and embed the AQUAPANEL® Reinforcing Mesh.

For fine finishing up to Q4 surface quality, use AQUAPANEL® Q4 Finish on AQUAPANEL® Joint Filler & Skim Coating – white.

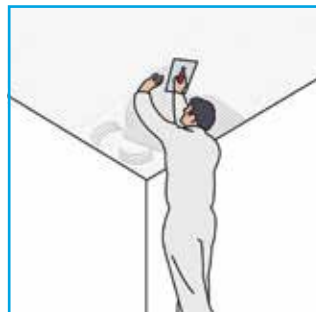

### Special notes

In rooms with continuous high humidity levels, such as commercial kitchens, swimming pools, saunas or chemical laboratories, it is necessary to provide improved corrosion protection for the metal framework.

When cutting AQUAPANEL® Cement Board Indoor, the distance of the screws from the board edge must be  $\geq 15$  mm. The distance between screws must be  $\leq 250$  mm.

Fasten the hanger of the framework with suitable, building authority-approved ceiling pins.

We recommend that expansion joints are included at maximum 15 m intervals. Align with the expansion joints in the background if practical.

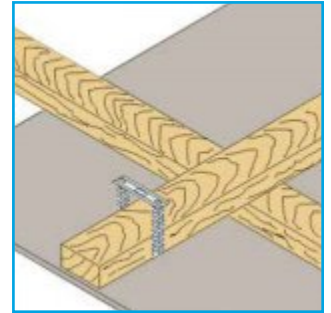
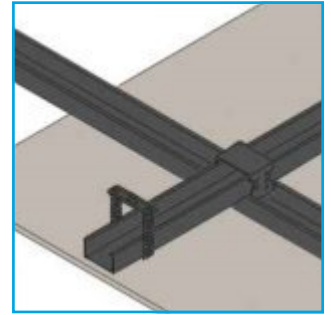

### Metal substructure

- The framework of suspended ceilings is constructed in accordance with EN 13964.
- Built-in units such as lamps and ventilation extractors may load the framework in terms of its bearing capability.
- Large loads must be attached to separate suspensions.
- Suspended ceilings with fire protection requirements may not be stressed with extra loads.

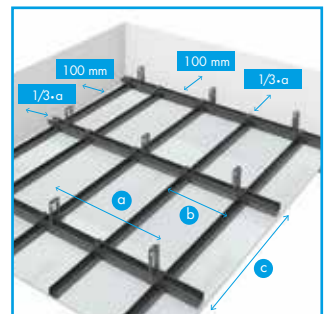

- a. Spacing hangers  $\leq 750$  mm
- b. Spacing of support profiles = 312.5 (300) mm
- c. Spacing of base profiles  $\leq 1000$  mm

## High performance in humid and damp areas

Makes it the clear winner in sporting facilities

- 100% water-resistant, making it the ideal backing board in your sports facility's bathroom and shower areas.
- Great for other humid or damp areas, such as changing rooms.
- Highly impact-resistant – perfect for use in indoor playing areas.











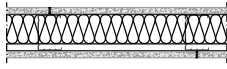
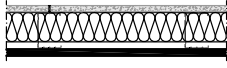

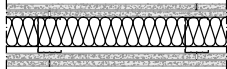
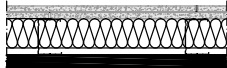
# Construction overview

## A complete system solution for walls and ceilings

### Interior walls

System	Drawing	Wall thickness	Profile	
		(mm)	(UW/CW)	
W 381 – Metal single stud frame wall, single-layer planking		75	50/0.6	
		100	75/0.6	
		125	100/0.6	
W 381 – Metal single stud frame wall, single-layer planking		75	50/0.6	
		100	75/0.6	
		125	100/0.6	
W 383 – Metal single stud frame wall, single-layer mixed planking		75	50/0.6	
		100	75/0.6	
		125	100/0.6	
W 382 – Metal single stud frame wall, double-layer planking		100	50/0.6	
		125	75/0.6	
		150	100/0.6	
W 382 – Metal single stud frame wall, double-layer planking		100	50/0.6	
		125	75/0.6	
		150	100/0.6	
W 384 – Metal single stud frame wall, double-layer mixed planking		100	50/0.6	
		125	75/0.6	
		150	100/0.6	
W 385 – Metal double stud frame wall, single-layer planking		130	2 x 50/0.6	
		180	2 x 75/0.6	
		230	2 x 100/0.6	
W 385 – Metal double stud frame wall, single-layer planking		130	2 x 50/0.6	
		180	2 x 75/0.6	
		230	2 x 100/0.6	
W 385 – Metal double stud frame wall, single-layer mixed planking		130	2 x 50/0.6	
		180	2 x 75/0.6	
		230	2 x 100/0.6	
W 385 – Metal double stud frame wall, double-layer planking		155	2 x 50/0.6	
		205	2 x 75/0.6	
		255	2 x 100/0.6	
W 385 – Metal double stud frame wall, double-layer planking		155	2 x 50/0.6	
		205	2 x 75/0.6	
		255	2 x 100/0.6	
W 385 – Metal double stud frame wall, double-layer mixed planking		155	2 x 50/0.6	
		205	2 x 75/0.6	
		255	2 x 100/0.6	







	Layer planking	Mineral wool	Maximum wall height (cm)*		Sound insulation (Rw, P)	Fire protection
	(mm)		(mm)/(kg/m³)	Installation range 1/2		
	12.5 AQUAPANEL® Cement Board Indoor	None	285/ – 450/400 500/445	285 400 400	– – –	EI 30 EI 30 EI 30
	12.5 AQUAPANEL® Cement Board Indoor	(50)/(14)	285/ – 450/400 500/445	285 400 400	43 46±3** 48±3**	EI 30 EI 30 EI 30
	12.5 AQUAPANEL® Cement Board Indoor 12.5 KNAUF GKF	(50)/(14)	300/ – 450/400 500/475	300 300 300	44 47±3** 48±3**	EI 30 EI 30 EI 30
	2 x 12.5 AQUAPANEL® Cement Board Indoor	None	330/ – 550/400 650/510	330 400 400	– – –	EI 90 EI 90 EI 90
	2 x 12.5 AQUAPANEL® Cement Board Indoor	(50)/(14)	330/ – 550/400 650/510	330 400 400	55 57 60	EI 90 EI 90 EI 90
	2 x 12.5 AQUAPANEL® Cement Board Indoor 2 x 12.5 Knauf GKF 2 x 12.5 Knauf Diamant	(50)/(14)	400/390 550/420 650/605	300 300 300	54 <sup>1</sup> 57 <sup>2</sup> 56±3**	EI 90 EI 90 EI 90
	12.5 AQUAPANEL® Cement Board Indoor	None	255/ – 500/380 600/400	255 400 400	– – –	EI 30 EI 30 EI 30
	12.5 AQUAPANEL® Cement Board Indoor	(50)/(14)	255/ – 500/380 600/400	255 400 400	53±3** 55±3** –	EI 30 EI 30 EI 30
	12.5 AQUAPANEL® Cement Board Indoor 12.5 KNAUF GKF	(50)/(14)	255/ – 500/380 600/400	255 300 300	52±3** 55±3** –	EI 30 EI 30 EI 30
	2 x 12.5 AQUAPANEL® Cement Board Indoor	None	260/ – 540/395 650/400	260 400 400	– – –	EI 90 EI 90 EI 90
	2 x 12.5 AQUAPANEL® Cement Board Indoor	(50)/(14)	260/ – 540/395 650/400	260 400 400	64 68±3** –	EI 90 EI 90 EI 90
	2 x 12.5 AQUAPANEL® Cement Board Indoor 2 x 12.5 Knauf GKF 2 x 12.5 Knauf Diamant	(50)/(14)	260/ – 540/395 650/400	260 300 300	66 <sup>2</sup> 67±3** –	EI 90 EI 90 EI 90

<sup>1</sup> Knauf GKF <sup>2</sup> Knauf Diamant \*Lower value is decisive. \*\*Calculated values

# Construction overview

## A complete system solution for walls and ceilings

### Interior walls

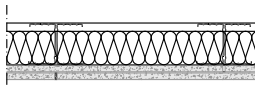
System	Drawing	Wall thickness	Profile	
		(mm)	(UW/CW)	
W 386 – Plumbing wall fishplated double stud frame, single-layer planking		min. 130 min. 180 min. 230	2 x 50/0.6 2 x 75/0.6 2 x 100/0.6	
W 386 – Plumbing wall fishplated double stud frame, single-layer planking		min. 130 min. 180 min. 230	2 x 50/0.6 2 x 75/0.6 2 x 100/0.6	
W 386 – Plumbing wall fishplated double stud frame, single-layer mixed planking		min. 130 min. 180 min. 230	2 x 50/0.6 2 x 75/0.6 2 x 100/0.6	
W 386 – Plumbing wall fishplated double stud frame, double-layer planking		min. 155 min. 205 min. 255	2 x 50/0.6 2 x 75/0.6 2 x 100/0.6	
W 386 – Plumbing wall fishplated double stud frame, double-layer planking		min. 155 min. 205 min. 255	2 x 50/0.6 2 x 75/0.6 2 x 100/0.6	
W 386 – Plumbing wall fishplated double stud frame, double-layer mixed planking		min. 155 min. 205 min. 255	2 x 50/0.6 2 x 75/0.6 2 x 100/0.6	
W 685 – Independent wall lining, single-layer planking		62.5 87.5 112.5	50/0.6 75/0.6 100/0.6	
W 685 - Independent wall lining with double studs, double-layer planking		75 100 125	50/0.6 75/0.6 100/0.6	

### Interior ceilings

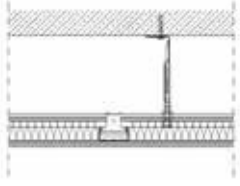
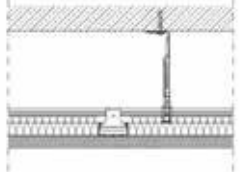
System	Drawing	Profile	Hangers	
D 282 – Suspended ceiling, single-layer planking		CD 60/27 UD 28/27	– 0.40 kN	
D 282 – Suspended ceiling, double-layer planking		CD 60/27 UD 28/27	– 0.40 kN	

	Layer planking	Mineral wool	Maximum wall height (cm)*		Sound insulation (R <sub>w</sub> , P)	Fire protection
	(mm)		(mm)/(kg/m <sup>3</sup> )	Installation range 1/2		
	12.5 mm AQUAPANEL® Cement Board Indoor	None	285/ – 450/400 500/445	285 400 400	– – –	EI 30 EI 30 EI 30
	12.5 mm AQUAPANEL® Cement Board Indoor	(50)/(14)	285/ – 450/400 500/445	285 400 400	50 57±3* –	EI 30 EI 30 EI 30
	12.5 mm AQUAPANEL® Cement Board Indoor 12.5 mm KNAUF GKF	(50)/(14)	300/ – 450/400 500/475	300 300 300	53 57±3* –	EI 30 EI 30 EI 30
	2 x 12.5 mm AQUAPANEL® Cement Board Indoor	None	330/ – 540/400 650/510	330 400 400	– – –	EI 90 EI 90 EI 90
	2 x 12.5 mm AQUAPANEL® Cement Board Indoor	(50)/(14)	330/ – 540/400 650/510	330 400 400	57 69±3* –	EI 90 EI 90 EI 90
	2 x 12.5 mm AQUAPANEL® Cement Board Indoor 2 x 12.5 mm KNAUF GKF	(50)/(14)	400/390 540/420 650/605	300 300 300	61 69±3* –	EI 90 EI 90 EI 90
	12.5 mm AQUAPANEL® Cement Board Indoor	None	255/ – 300/380 400/400	– – –	– – –	– – –
	2 x 12.5 mm AQUAPANEL® Cement Board Indoor	(40/30)	260/ – 350/395 425/400	260 300 300	– – –	EI 30 EI 30 EI 30

\*Lower value is decisive. \*\*Calculated values

	Layer planking	Mineral wool	Ceiling weight	Distance profiles and hangers	Fire Protection
	12.5 mm AQUAPANEL® Cement Board Indoor	None – –	– approx. 16 –	Base profile: 1000 mm Supporting profile: 300 mm Hangers: 750 mm	– – –
	2 x 12.5 mm AQUAPANEL® Cement Board Indoor	(40)/(14) – –	– approx. 31 –	Base profile: 750 mm Supporting profile: 300 mm Hangers: 750 mm	EI 30 / EI 45* – –

\* Depending to local regulations and requirements

## Spectacular design options

For distinctive walls and ceilings

- Full-board bending radius of 1 m makes it easy to create stylish curved walls.
- Large glass, ceramic, stone and mosaic tile coverings for splash areas – up to 600 x 600 mm or larger sizes.
- Highly resistant to chlorine-based cleaning agents.
- Simple to remove and replace in line with changing designs.

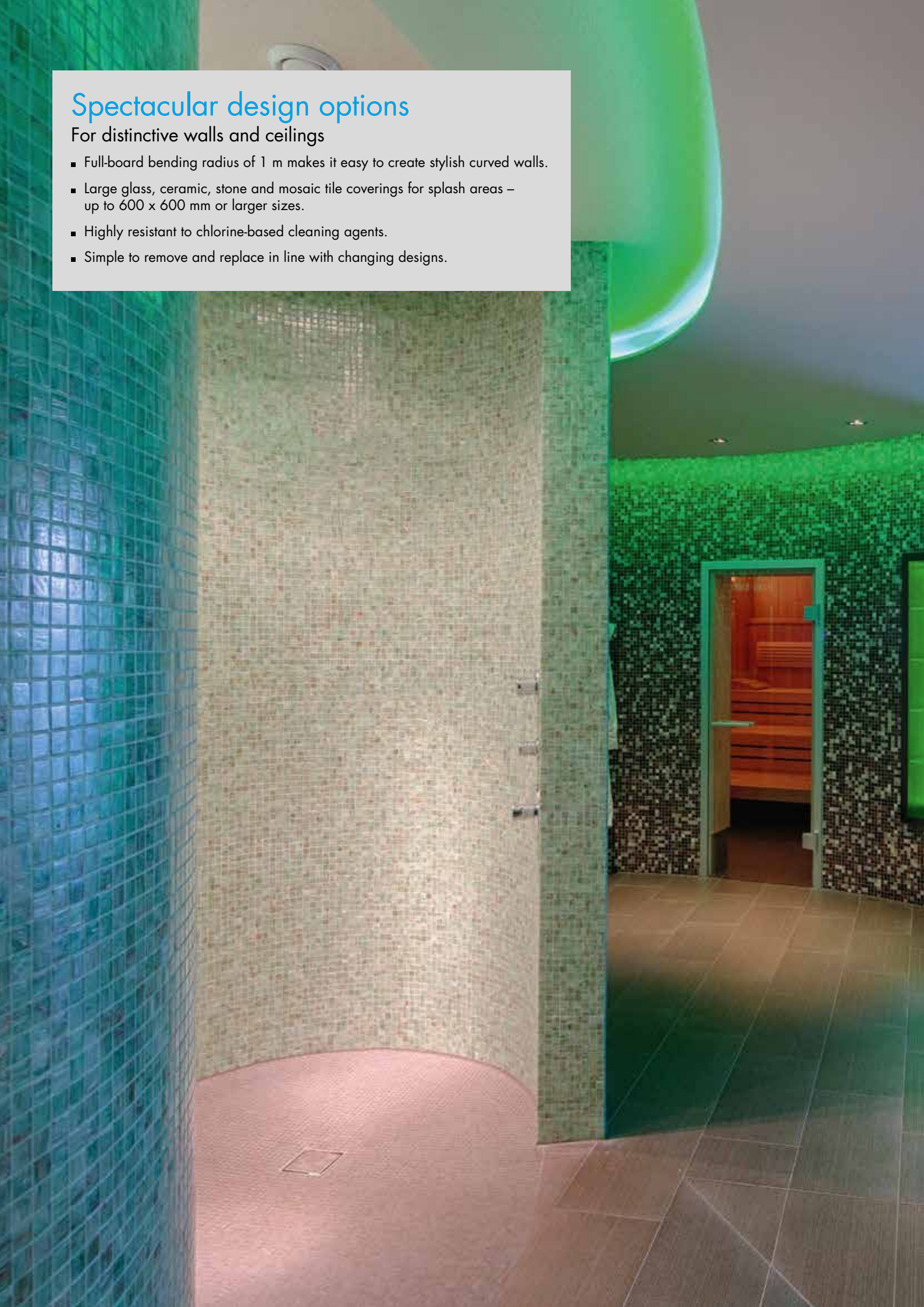

# Curved constructions

## Flexible design for walls and ceilings

### Applying AQUAPANEL® Cement Board Indoor to curved constructions

For everything from arches to rounded walls, AQUAPANEL® Cement Board Indoor provides unlimited design flexibility and ease. With a full-board bending radius of 1 m, while retaining robustness and resistance, it opens up more options for tackling wet and humid environments. For installation, use metal shears to cut and fit the UW profile to the desired radius, and crimp the CW profile to the perforated UW profile. Before installation, bend the panel – the fine cracks that appear on the surface will not cause any loss of performance. Max. stud spacing  $\leq 300/312.5$  mm (external radius).

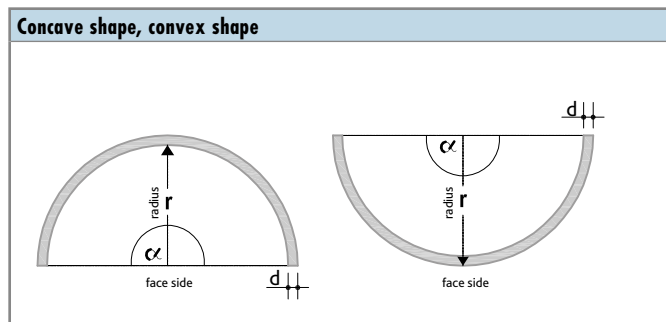

Board thickness	Bending radius $r$ of AQUAPANEL® Cement Board Indoor
$d$	Width 900 mm, 1200 mm, 1250 mm
mm	mm
12.5	$\geq 1000$

**Unwound length L**

Angle $\alpha$ 90°	All angles up to $\alpha$ 180°
--------------------	--------------------------------

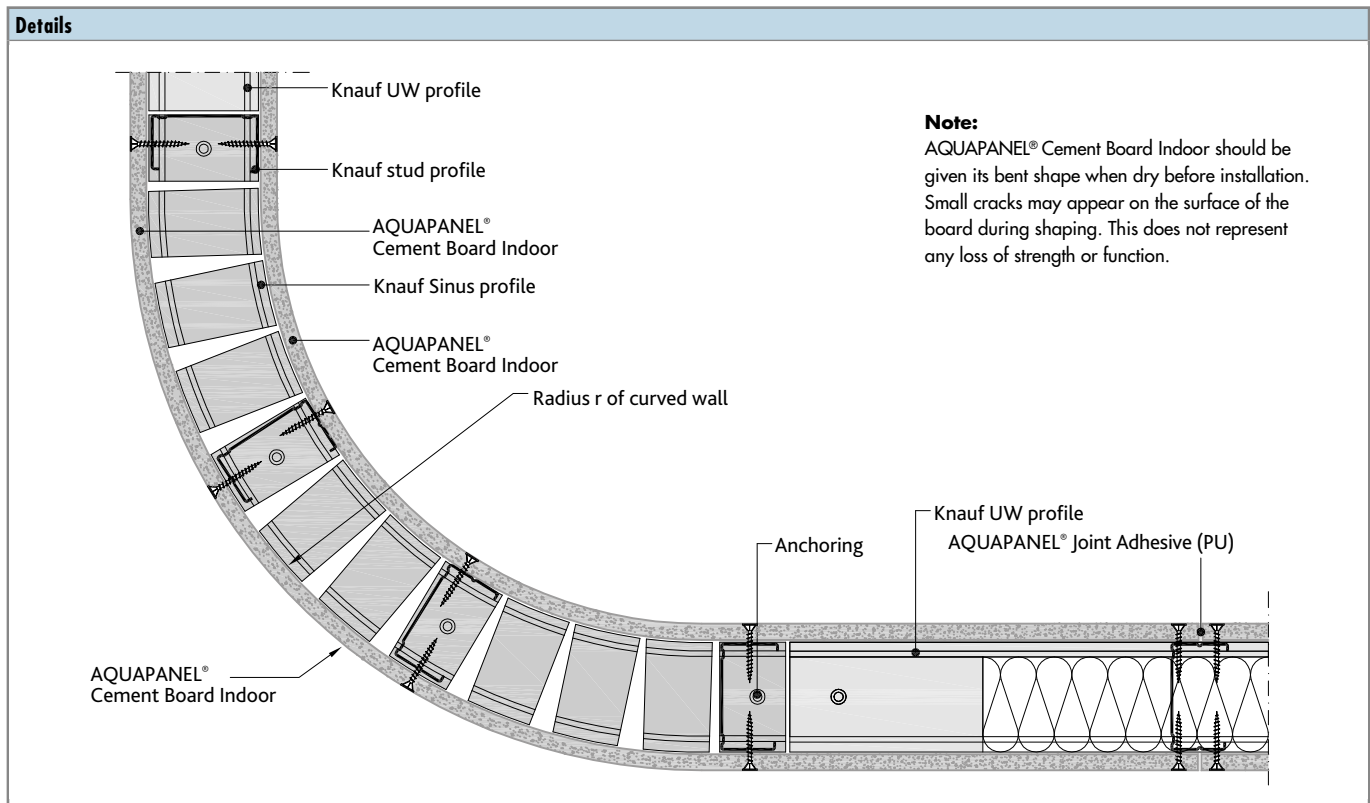
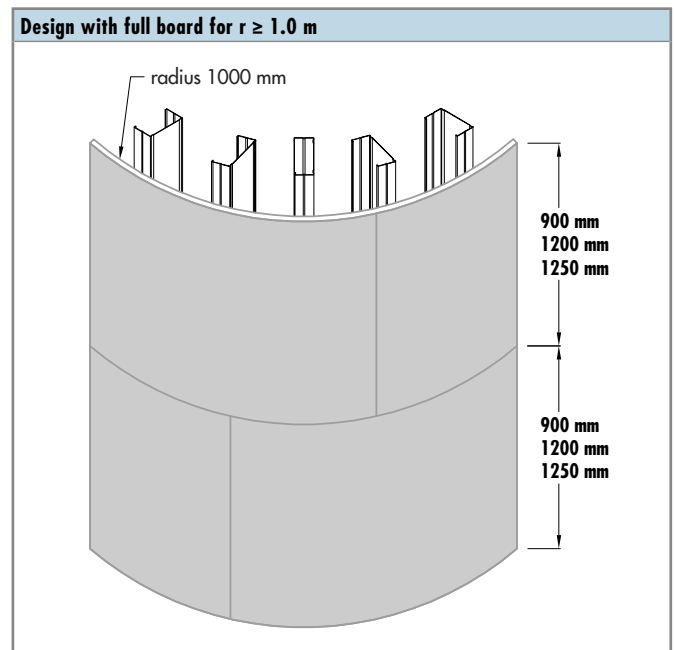

# Load fastening

## Load fastenings for walls and ceilings

### Fastening loads to walls

#### Heavy bracket loads up to 1.5 kN/m (trusses, crossbeams)

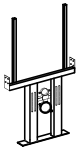

Bracket loads over 0.7 kN/m to 1.5 kN/m wall length are to be installed onto the substructure via main trusses and crossbeams.

#### Note:

According to DIN 18183, single-layer walls may be loaded at any point by bracket loads up to 0.4 kN/m wall length taking into account the leverage (cabinet height > 30 cm) and eccentricity (cabinet width < 60 cm). Fastening distance of the plugs is > 75 mm. The bracket loads must be fastened with at least two cavity fixing plugs of plastic or metal, e.g. Fischer FU, UX, K54; GKS; Hilti HLD. For all plugs stainless steel screws  $d = 4-6$  mm are recommended.

#### Other bracket loads up to 0.7 kN/m (plug)

Plastic cavity fixing plugs

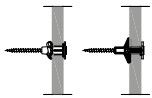

Metal cavity fixing plugs



Wall cabinets

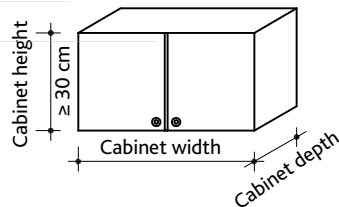

#### Bracket loads up to 15 kg (hook)

Load  
5 kg



Load  
10 kg



Load  
15 kg



#### Note:

Light objects e.g. pictures can be fastened with X-hooks.

Up to 40 kg – cavity dowel

For anchoring cantilever loads up to 0.4 kN/m or 0.7 kN/m

AQUAPANEL® Cement Board Indoor	Dowel loading – tension and shear load (kg)				
	Universal nylon dowel <sup>1</sup>		Plastic cavity dowel <sup>2</sup>	Plastic toggle dowel <sup>3</sup>	Plasterboard dowel <sup>4</sup>
–	Ø 6 mm	Ø 8 mm	Ø 10 mm	Ø 8 mm	
1 x 12.5 mm	20	25	20	25	10
2 x 12.5 mm	35	40	35	40	20

<sup>1</sup> Universal nylon Plug: e.g. Fischer FU, UX. <sup>2</sup> Plastic cavity plug: e.g. Hilti HLD. <sup>3</sup> Plastic toggle plug: e.g. Fischer K 54. <sup>4</sup> Plasterboard dowel: e.g. Fischer GKS. For all mentioned dowels the use of stainless steel screws is recommended.

### Fastening loads to ceilings

Light loads, which do not exceed the load-bearing capacity of a light suspended ceiling, may be fastened to AQUAPANEL® Cement Board Indoor, taking advantage of the panel's in-built strength and robustness. Heavier loads must be secured separately to the original ceiling using tilting ceiling hooks or spring toggle ceiling hooks, with a maximum load-bearing capacity of 20 kg in single-layer panelling and 25 kg in double-layer panelling.

#### Ceiling hooks

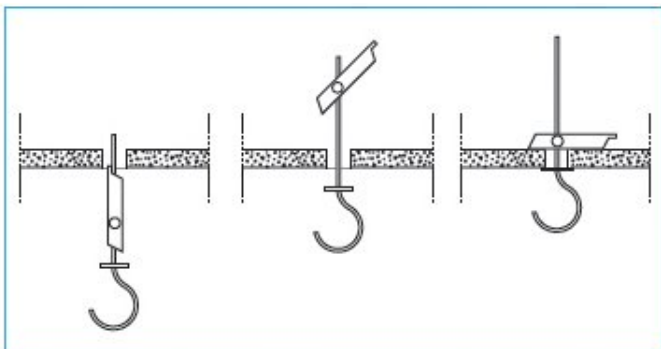

Tilting ceiling hooks

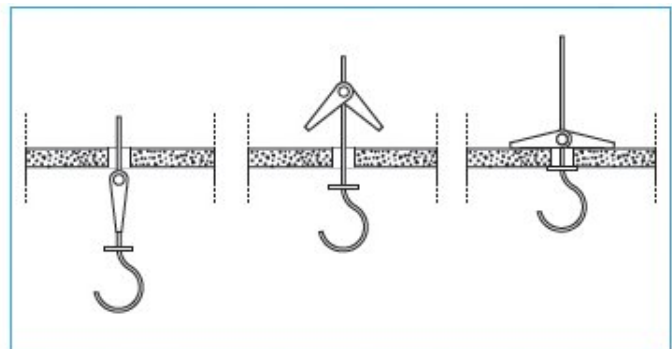

Spring toggle ceiling hooks

# Load fastening

## Permitted console loads

### Permitted console loads

Light partition walls built with AQUAPANEL® Cement Board Indoor can accept console loads of different sizes. Should loads be inserted in double-layer walls, the stud rows must be connected using consoles to ensure tensile strength. The size and geometry of the load must be monitored for all walls. A deciding size is the "load height", i.e. the distance of the load outer edge from the wall, or the height of a hanging shelf or hanging cabinet. The following cases can be distinguished depending on the size and height of the load.

#### Light console loads up to 40 kg/m wall length

These can be arranged on any position of the wall or facing panel. If the load is attached to the panel, the distance of the fastening points from each other must be at least 75 mm. Loads of up to 40 kg per metre wall length at a load height of 60 cm are considered light console loads. Loads can be increased if the load height is low.

Maximum size "light console loads" as a function of load depth						
Load depth (cm)	10	20	30	40	50	60
Permissible console load P (kg/m wall length)	78	71	63	55	48	40

#### Other console loads of 40 to 70 kg/m wall length

Other console loads can be attached in any position on a single or double stud installation with double-layer panelling of AQUAPANEL® Cement Board Indoor. With double stud walls, the stud rows must be fixed with consoles to ensure tensile strength. Loads of between 40 and 70 kg per metre wall length at a load height of 60 cm are considered medium console loads. Loads can be increased if the load height is low.

Maximum size "other console loads" as a function of load depth b						
Load depth (cm)	10	20	30	40	50	60
Permissible console load P (kg/m wall length)	107	100	93	85	78	70

#### Heavy console loads of 70 to 150 kg/m wall length

Heavy console loads must be attached to special construction parts such as cross beams, console frames or cross member bracing. Cross beams and cross member braces are directly linked to the framework so that loads can be securely taken into the framework. Supporting frames are fastened to the framework depending on the type of construction, but are generally anchored directly to the original floor.

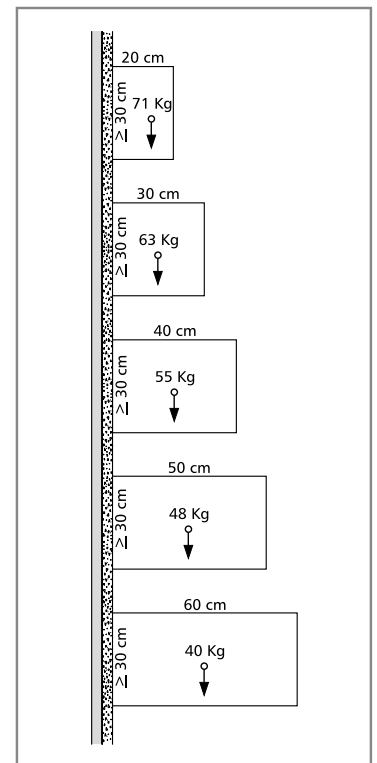

Light console loads

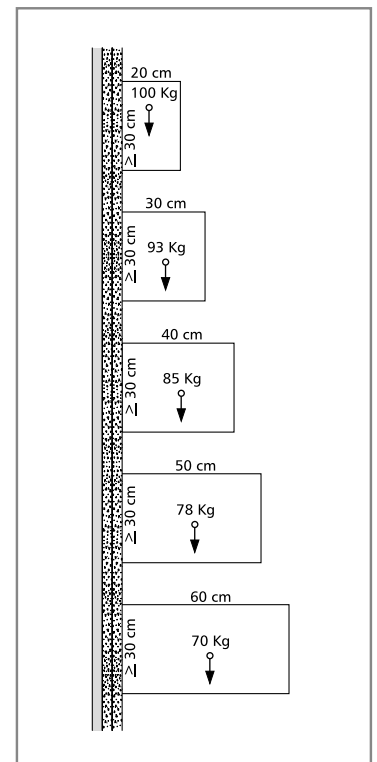

Other console loads

## Extreme temperature resistance

Perfect for wellness centres and steam saunas

- Suitable for sustained temperatures of up to 70°C.
- 100% water-resistant – will never swell, soften, flake or crumble.
- Inorganic, so resistant to mould and mildew.
- An ultra-hygienic, ecological and safe building material.



# Access doors

## Access doors for interior walls and ceilings

AQUAPANEL® Access Doors can be installed in any partition or plumbed wall constructed from AQUAPANEL® Cement Board Indoor panels. Easy to install and safe to handle, they provide greater convenience and quality, as well as being tested for imperviousness to water in accordance with the BBW 0215069 test report issued by LGA Bayern.

### AQUAPANEL® Access Door for splash water protection

This is a water spray protected version which offers a dust-proof and airtight seal – perfect for universal application in walls and ceilings, as well as single or double layer panels or for use with tiles and plaster. The door features a coated edge.

### AQUAPANEL® Access Door for humid rooms

This second version is for use in areas that don't require spray water protection. It can also be supplied with a coated edge, if required, allowing easy application of AQUAPANEL® Q4 Finish, and is suitable for use in walls or ceilings. Versions for single and double panels are available.

### Installing AQUAPANEL® Access Door for splash water protection

The door can be installed either when building the wall substructure or afterwards. Make an opening 20 mm larger than the frame of the AQUAPANEL® Access Door. Construct a frame from CD or CW/UW profiles according to the dimensions of the access door. When installing in a ceiling, fasten an additional four suspension brackets at the corners of the access door. Position, align and screw the frame of the door onto the profile frame. Now place the inner cover in position and check that it closes properly. The panelling should be screwed to the frame using AQUAPANEL® Maxi Screws SN or SB.

**WARNING:** The screw length depends on the panel. At least three screws must be used for each side of the frame. The maximum distance between screws is 150 mm. There should be no joins in the panels near the access door. For wall-mounted access doors, allow a clearance of  $\geq 50$  mm at the top third of the panel for opening.

### Installing AQUAPANEL® Access Door for humid rooms

Cut an opening 12 mm larger than the access door (equal inside dimensions). If required, make an additional external frame from CD or CW profiles according to the dimensions of the access door. Ensure distances of minimum 30 mm and maximum 100 mm between the opening and the CD or UW profiles (in the case of walls to the profile frame, with ceilings on at least two opposite sides). When replacing suspended ceiling profiles, additional suspension brackets are required. Place the outer frame of the access door in the opening, position on the panelling, align and screw down. Now place the inner cover in position and check that it closes properly. If the distance from installations in the wall or ceiling is less than 200 mm, the external frame must be built into the AQUAPANEL® Cement Board Indoor before the area is panelled.

AQUAPANEL® Cement Board Indoor	Wall
Panel thickness (mm)	1 x 12.5 2 x 12.5
Standard sizes W x H (LD in mm)	300 x 300 400 x 400 500 x 500 600 x 600

Dimensions	AQUAPANEL® Access Door Splash Water Protection	AQUAPANEL® Access Door Humid Rooms
Order size	500 mm x 500 mm	500 mm x 500 mm
Inside dimensions	465 mm x 465 mm	500 mm x 500 mm
Panel opening	520 mm x 520 mm	512 mm x 512 mm

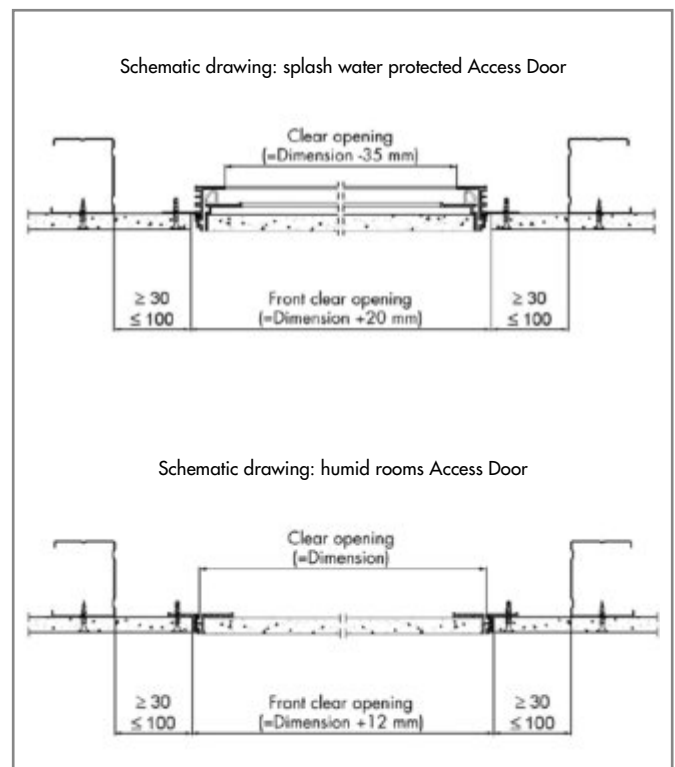

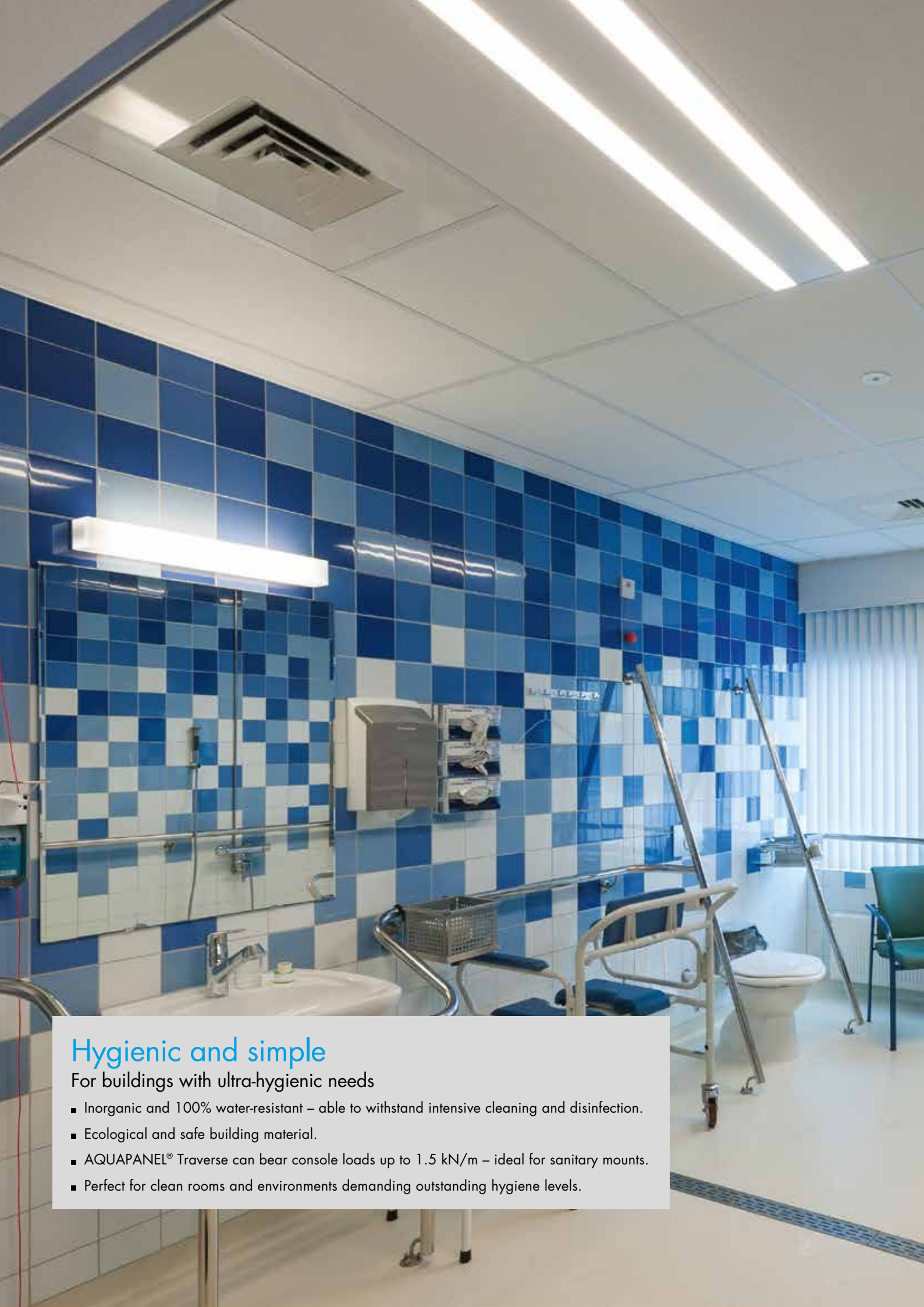

## Hygienic and simple

For buildings with ultra-hygienic needs

- Inorganic and 100% water-resistant – able to withstand intensive cleaning and disinfection.
- Ecological and safe building material.
- AQUAPANEL® Traverse can bear console loads up to 1.5 kN/m – ideal for sanitary mounts.
- Perfect for clean rooms and environments demanding outstanding hygiene levels.

# Technical product details

## Physical properties and material consumption

### Physical properties

<b>Length (mm)</b>	1200/1250/2400/2500	900/2000/2400/2500/ 2600/2800/3000	900/2000/2500/2600
<b>Width (mm)</b>	900	1200	1250
<b>Thickness (mm)</b>	12.5		
<b>Min. bending radius for 900/1200/1250 mm wide board</b>	1		
<b>Weight (kg/m<sup>2</sup>)</b>	Approx. 11		
<b>Dry bulk density (kg/m<sup>3</sup>) according to EN 12467</b>	Approx. 750		
<b>Bending strength (MPa) according to EN 12467</b>	≥ 7		
<b>pH-value</b>	12		
<b>Building material class according to EN 13501</b>	A1 non-combustible		
<b>Linear moisture movement 30% to 90% humidity (23±2°C) according EN 12467</b>	L <sub>m</sub> = 0.0606%		
<b>Water vapour diffusion resistance according DIN EN ISO 7783</b>	μ = 25		
<b>Thermal conductivity (dry) according to DIN EN 12664</b>	λ <sub>10,1r</sub> = 0.1509 W/(m·K)		
<b>Thermal conductivity (wet) according to DIN EN 12664</b>	λ <sub>23/80</sub> = 0.188 W/(m·K)		

### Material consumption

#### Interior walls

Material	Unit	Single layer (per m <sup>2</sup> )	Double layer (per m <sup>2</sup> )
AQUAPANEL® Cement Board Indoor	m <sup>2</sup>	1	2
AQUAPANEL® Maxi Screws (SN, SB)	pieces; stud spacing 600/625 mm	15	21
AQUAPANEL® Joint Adhesive (PU)	ml	50	50
AQUAPANEL® Tape (10 cm)	m	2.1	2.1
AQUAPANEL® Joint Filler & Skim Coating – white	kg/m <sup>2</sup> /mm (joint treatment)	0.7	0.7
	kg/m <sup>2</sup> /mm (full-surface skim coat)	0.7	0.7
AQUAPANEL® Board Primer	g	40-60	40-60
AQUAPANEL® Reinforcing Mesh	m <sup>2</sup>	1.1	1.1
AQUAPANEL® Q4 Finish	kg; layer thickness 1 mm	1.7	1.7
	kg; layer thickness 2 mm	3.4	3.4

#### Interior ceilings

Material	Unit	Single layer (per m <sup>2</sup> )	Double layer (per m <sup>2</sup> )
AQUAPANEL® Cement Board Indoor	m <sup>2</sup>	1	2
AQUAPANEL® Maxi Screws	pieces	25	50
AQUAPANEL® Joint Filler & Skim Coating – white	kg/m <sup>2</sup> (joint treatment)	0.7	1.4
	kg/m <sup>2</sup> /mm (full-surface skim coat)	0.7	0.7
AQUAPANEL® Tape (10 cm)	m	2.1	4.2
AQUAPANEL® Board Primer	g	Approx. 50	Approx. 50
AQUAPANEL® Reinforcing Mesh	m <sup>2</sup>	1.1	1.1

# KNAUF

All technical changes reserved. Only the current printed instructions are valid. Our warranty is expressly limited to our products in flawless condition. The constructional and structural properties and characteristic building physics of Knauf systems can solely be ensured with the exclusive use of Knauf system components, or other products expressly recommended by Knauf. All application quantities and delivery amounts are based on empirical data that are not easily transferable to other deviating areas. All rights reserved. All amendments, reprints and photocopies, including those of excerpts, require the express permission of Knauf Aquapanel GmbH & Co. KG, Zur Helle 11, 58638 Iserlohn, Germany.

AQUAPANEL® is a registered trademark.

© 2017 EN-06/17



## AQUAPANEL®

[www.AQUAPANEL.com](http://www.AQUAPANEL.com)

AQUAPANEL® Cement Board Indoor

Knauf Aquapanel GmbH & Co. KG  
Zur Helle 11  
58638 Iserlohn  
Germany