

ENVIRONMENTAL PRODUCT DECLARATION

as per ISO 14025 and EN 15804+A2

Owner of the Declaration	Knauf Gips KG
Publisher	Institut Bauen und Umwelt e.V. (IBU)
Programme holder	Institut Bauen und Umwelt e.V. (IBU)
Declaration number	EPD-KNA-20250175-IBA1-EN
Issue date	21.10.2025
Valid to	20.10.2030

Knauf Fireboard
Knauf Gips KG

www.ibu-epd.com | <https://epd-online.com>



ECO PLATFORM

EPD
VERIFIED



KNAUF Fireboard AI-DIN 18180 25.0 mm

1. General Information

Knauf Gips KG

Programme holder

IBU – Institut Bauen und Umwelt e.V.
 Hegelplatz 1
 10117 Berlin
 Germany

Declaration number

EPD-KNA-20250175-IBA1-EN

This declaration is based on the product category rules:

Plasterboard, 01.08.2021
 (PCR checked and approved by the SVR)

Issue date

21.10.2025

Valid to

20.10.2030



Dipl.-Ing. Hans Peters
 (Chairman of Institut Bauen und Umwelt e.V.)



Florian Pronold
 (Managing Director Institut Bauen und Umwelt e.V.)

Knauf Fireboard

Owner of the declaration

Knauf Gips KG
 Am Bahnhof 7
 97346 Iphofen
 Germany

Declared product / declared unit

Gypsum board with fleece reinforcement Knauf Fireboard type GM-F according to *EN 15283-1*, 1 m², board thickness 20.0 mm, weight of board approx. 16.4 kg/m²

Scope:

This EPD covers 100 % of manufacture of the gypsum board with fleece reinforcement Knauf Fireboard GM-F. This board is manufactured in Knauf plant Rottleberode (Germany). The life cycle assessment is based on production data for 2024.

In order to enable the user of the EPD to calculate the LCA results for different board thicknesses, the EPD contains the respective calculation rules.

The owner of the declaration shall be liable for the underlying information and evidence; the IBU shall not be liable with respect to manufacturer information, life cycle assessment data and evidences.

The EPD was created according to the specifications of EN 15804+A2. In the following, the standard will be simplified as *EN 15804*.

Verification

The standard EN 15804 serves as the core PCR	
Independent verification of the declaration and data according to ISO 14025:2011	
<input type="checkbox"/>	internally
<input checked="" type="checkbox"/>	externally



Dr.-Ing. Wolfram Trinius,
 (Independent verifier)

2. Product

2.1 Product description/Product definition

Knauf Fireboard is a fibre-reinforced gypsum board with fleece reinforcement. The board is non-combustible (A1) for premium quality fire protection.

For the placing on the market of the product in the European Union/European Free Trade Association (EU/EFTA) (with the exception of Switzerland) *Regulation (EU) No. 305/2011 (CPR)* applies. The product Knauf Fireboard GM-F needs a declaration of performance taking into consideration *EN 15283-1:2009 Gypsum boards with fibrous reinforcement - Definitions, requirements and test methods* and the CE-marking.

For the application and use the respective national provisions apply.

2.2 Application

Knauf Fireboard is used in special drywalling systems. The board is suitable for the following systems:

- Steel beam and steel column encasements
- Encasement of wooden columns and wooden beams
- Room-in-room systems Knauf Cubo
- Free-spanning ceilings F90
- Ceiling linings and suspended ceilings
- Installation shaft walls
- Metal stud partitions
- Fire protection encasement of timber frames and steel components
- Fire resistance cladding of trapezoid sheet metal
- Engineered fire protection / special solutions

2.3 Technical Data

The technical datasheets can be downloaded from the website. <https://knauf.com>

Constructional data

Name	Value	Unit
Density	≥ 780	kg/m ³
Flexural breaking load traverse direction acc. to EN 15283-1 (depends on board thickness)	≥ 336	N/mm ²
Flexural breaking load longitudinal direction acc. to EN 15283-1 (depends on board thickness)	≥ 860	N/mm ²
Water vapour resistance factor μ dry acc. to EN ISO 10456	10	
Water vapour resistance factor μ wet acc. to EN ISO 10456	4	
Thermal conductivity λ acc. EN ISO 10456	0.23	W/(mK)
Max. limit for long term temperature exposure	≤ 50	°C
Arc behaviour number acc. to DIN VDE 0303-5	1.1.1.2	LV

Further information is available in the technical data sheet *K7501_DSP.de* under <https://knauf.com>.

Performance data of the product in accordance with the declaration of performance with respect to its essential characteristics according to *EN 15283-1:2009 Gypsum boards with fibrous reinforcement - Definitions, requirements and test methods*.

2.4 Delivery status

Gypsum boards Knauf Fireboard GM-F according to EN 15283 are delivered with a board thickness of 20.0 mm as well as a size of 2000 mm (length) and 1250 mm (width) with a full longitudinal edge (VK) and front cut square edge (SSK). Knauf Fireboard GM-F is also available with customized dimensions of length and width.

Further board thicknesses (12.5, 15, 25 and 30 mm) are also available.

2.5 Base materials/Ancillary materials

Knauf Fireboard GM-F consists of a special gypsum core (> 90 %) covered with fleece reinforcement (< 4 %), containing small amounts (< 5 %) of glass fibres, tensides and further additives.

This product at least one partial article contains substances listed in the candidate list (date: 27.06.2024) exceeding 0.1 percentage by mass: no

This product at least one partial article contains other carcinogenic, mutagenic, reprotoxic substances in categories 1A or 1B which are not on the candidate list, exceeding 0.1 percentage by mass: no

Biocide products were added to this construction product or it has been treated with biocide products (this then concerns a treated product as defined by the (EU) Ordinance on Biocide Products No. 528/2012): no

2.6 Manufacture

The manufacturing process for gypsum boards is shown in figure 1.

MANUFACTURING OF GYPSUM BOARDS

- ① Boardliner of visible side is fed to the boardline and cut on edges
- ② Gypsum slurry of raw materials is spread on boardliner
- ③ Feeding of second sheet of board liner (backside of plasterboard)
- ④ Setting section
- ⑤ Shears
- ⑥ Turning table
- ⑦ Multi-level dryer
- ⑧ Trimming of transverse edges
- ⑨ Stacking of boards

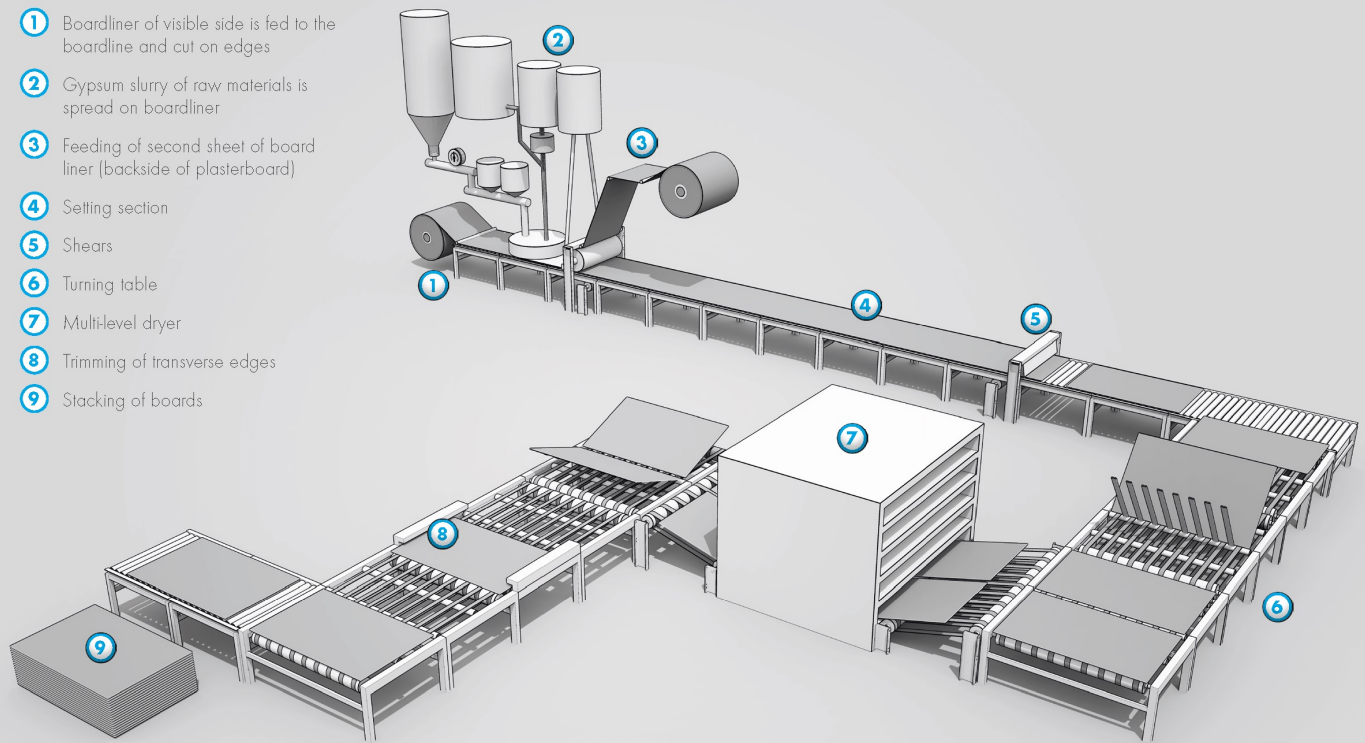

Figure 1: Manufacturing process of gypsum boards

The components of Knauf Fireboard GM-F are suspended in water and spread on a continuous sheet of glass fibre fleece (visible face, lower layer). Beforehand, the fleece is cut on the sides for edge shaping. The slurry is covered with a second sheet of fleece (back surface) in the forming station and the edges of the visible face fleece are flipped upwards. On the subsequent board line the gypsum sets continuously and is dried in a multi-level drier to the permitted residual moisture level. Drying is followed by the cutting of the boards to the desired lengths. All processes within the company are certified according to *ISO 9001*.

2.7 Environment and health during manufacturing

The manufacturing plant is certified according to *ISO 45001* and *ISO 50001* and meets the standard of the *Federal Immission Control Act (BImSchG)*.

Natural gypsum is used in the production of Knauf Fireboard GM-F. Production waste as well as dust from the filtration plants are recycled internally and fed back into the production of plasterboards.

2.8 Product processing/Installation

Storage

Knauf Fireboard GM-F should be stored indoors under dust free and dry conditions in a horizontal position.

Application

Knauf Fireboard GM-F is mechanically fixed to the substrate. During application, dust thresholds are to be observed

according to *TRGS 900* and *TRGS 559*. The application and installation should follow the instruction sheets provided under <https://knauf.com>. Endless filament glass fibres are used in the manufacturing of Knauf Fireboard GM-F for enhanced fire protection. These fibres do not fan out during application and therefore no fibre dusts according to *TRGS 521* occur.

2.9 Packaging

Gypsum boards Knauf Fireboard GM-F are stacked on reusable wooden pallets, covered with two rejected boards per pallet and strapped with PE straps. The edges are protected with galvanized steel angles.

2.10 Condition of use

Knauf Fireboard is used in all interior fitting areas as cladding and for equipping drywalling systems with premium quality fire protection. There is no change in the chemical composition during use.

2.11 Environment and health during use

Since Knauf Fireboard GM-F is particularly designed for fire protection, it contributes to health in exceptional situations. According to the emission test of Eurofins Product Testing A/S (*Eurofins2021*), no hazardous substances are emitted above permissible thresholds during use. The emission test showed that Knauf Fireboard GM-F undercuts the required thresholds of the AgBB standard.

2.12 Reference service life

There was no reference service life determined according to *ISO 15686-1*. However, a service life of 50 years can be considered for gypsum plasterboards according to the Guideline for Sustainable Building *BBSR2017*. There are no

influences on the ageing of Knauf Fireboard GM-F during use when following the established engineering practice.

2.13 Extraordinary effects

Fire

The reaction to fire of gypsum board Knauf Fireboard GM-F is classified as follows according to EN 520 in conjunction with EN 13501-1.

Fire protection

Name	Value
Building material class	A1

A1 = non-combustible

Knauf Fireboard GM-F offers outstanding fire protection. This is due to the fact that the gypsum core contains crystal water which evaporates when exposed to fire thereby consuming energy by means of conversion. The fleece reinforcement and the glass fibres contained in the gypsum core improve the structural cohesion under fire. The temperature on the side facing away from the fire remains constant at approx. 110 °C over a longer period of time depending on the board thickness. The resulting dehydrated gypsum layer offers increased thermal insulation.

Water

Knauf Fireboard GM-F shows a small tendency to swell or shrink within changes of the climatic conditions. However, a permanent exposure to wet conditions or very high levels of relative humidity may lead to a decrease in strength. An instruction sheet about restoration of flood damage is available under www.knauf.com/BDSH2013.

Mechanical destruction

Minor damages on gypsum boards Knauf Fireboard GM-F can be mended with suitable gypsum-based filling materials. The installation with screws allows an easy exchange of heavily damaged boards. In this case, the substructure should be

examined, too, and replaced if necessary.

2.14 Re-use phase

Re-use

Once gypsum boards Knauf Fireboard GM-F are installed, they are not suited for re-use in an unchanged way. Prior to collection, gypsum boards Knauf Fireboard GM-F should be separated from other used building materials and pruned of foreign matter, e.g., metals from the substructure already on site for easier recycling or disposal.

Further use

Residual materials from new gypsum boards Knauf Fireboard GM-F, e.g., from cut waste at the building site, can be disposed of at a landfill.

Recycling

In principle, gypsum boards can be recycled. Currently, Knauf Fireboard GM-F is not recycled.

2.15 Disposal

Gypsum boards Knauf Fireboard GM-F have to be disposed of in compliance with the following waste codes of the *European Waste Catalogue EWC*:

- 17 09 04 - mixed construction and demolition wastes other than those mentioned in 17 09 01, 17 09 02 and 17 09 03
- 17 08 02 - gypsum-based construction materials other than those mentioned in 17 08 01

In Germany, Knauf Fireboard GM-F are to be disposed of at landfills of landfill category 1 or higher according to the regulation of landfills *DepV*.

2.16 Further information

Further information about Knauf Fireboard GM-F, e.g., the technical data sheet or the product safety information sheet are available at <https://knauf.com>.

3. LCA: Calculation rules

3.1 Declared Unit

The declared unit is 1 m² of Knauf Fireboard GM-F with a thickness of 20.0 mm, weight approx. 16,4 kg/m².

Declared unit and mass reference

Name	Value	Unit
Declared unit	1	m ²
conversion factor from 1 m ² to 1 kg	0.061	-
Grammage	16.4	kg/m ²
Layer thickness	0.02	m
Gross density	≥ 780	kg/m ³

3.2 System boundary

The EPD is a declaration cradle to gate with options, modules C1–C4, and module D (A1–A3, C, D, and additional modules A4 and A5).

This Environmental Product Declaration according to EN 15804 contains:

- Provision of raw materials and transport to plant, production of boards (A1-A3) including thermal energy for calcination and drying (from natural gas, geographic scope: DE), as well as electricity (electricity grid mix DE)
- Transport to building site (A4)
- Installation at building site (A5) including the incineration of transport packaging
- Disassembly (C1)

- Transport to landfill site (C2)
- Landfilling at end of life (C4)
- Credits in D from incineration of packaging material in module A5

The life cycle of Knauf Fireboard GM-F is outlined in Figure 2.

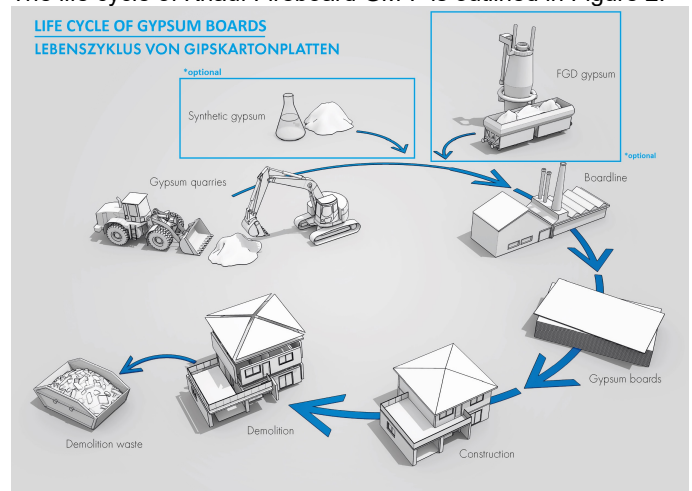

Figure 2: Principal life cycle of gypsum boards

3.3 Estimates and assumptions

For modelling the life cycle of Knauf Fireboard GM-F, the electricity grid mix for Germany has been chosen.

Some raw materials were not available in the used LCA calculator. Some of them have been substituted with chemically similar substances. Transport to the building site (module A4) as well as transport from the building site to the landfill (module C2) is calculated with a standard distance of 100 km. These are not actual transport distances but shall facilitate the extrapolation to the 'real' distances on building level.

It is assumed that wooden pallets are re-used 5 times and incinerated at their end of life.

3.4 Cut-off criteria

All raw materials for the manufacturing of Knauf Fireboard GM-F, the required energy, water and the resulting emissions are considered in the life cycle assessment. That way, recipe components with a share even smaller than 1 % are included. Cut-off rules as required by EN 15804+A2 are respected. The environmental impacts imposed by these cut-offs are considered neglectable. All neglected processes contribute less than 5 % to the total mass or less than 5 % to the total energy consumption

3.5 Background data

For modelling the BV Gips LCA tool, version 1.0 created by Sphera Solutions GmbH, IBU-BVG-202101-LT1-DE has been used.

3.6 Data quality

The LCA of the gypsum board Knauf Fireboard GM-F is modelled by using the BV Gips LCA tool provided by Sphera. For some raw materials no direct match was available in the

LCA tool datasets. The sum of these substituted materials is smaller than 5% of mass. The substitution follows a conservative approach, ensuring that it has low impacts on the displayed results.

With respect to technological, geographic and time representativeness, the overall data quality is evaluated to be 'satisfactory'.

3.7 Period under review

The modelling is based on the annual production of Knauf Fireboard GM-F in production year 2024.

3.8 Geographic Representativeness

Land or region, in which the declared product system is manufactured, used or handled at the end of the product's lifespan: Global

3.9 Allocation

Allocations in the foreground data have only been applied for energy data which is monitored on an annual basis for the whole plant. The energy was allocated by taking production amounts into account.

3.10 Comparability

Basically, a comparison or an evaluation of EPD data is only possible if all the data sets to be compared were created according to EN 15804 and the building context, respectively the product-specific characteristics of performance, are taken into account. The used background database is GaBi ts (SP40).

4. LCA: Scenarios and additional technical information

Characteristic product properties of biogenic carbon

Information on describing the biogenic carbon content at factory gate

Name	Value	Unit
Biogenic carbon content in product	-	kg C
Biogenic carbon content in accompanying packaging	0.031	kg C

The factors shown in the following table can be used to calculate the biogenic carbon in accompanying packaging for different board thicknesses. For this conversion the value for the 20.0 mm must be multiplied with the scaling factors.

Factors to convert the biogenic carbon in accompanying packaging			
12.5 mm	15.0 mm	25.0 mm	30.0 mm
0.60	0.75	1.25	1.50

Note: 1 kg of biogenic carbon is equivalent to 44/12 kg of CO₂.

Product Stage (A1-A3)

Supply of raw materials (A1)

Knauf Fireboard GM-F consists of a gypsum core which is reinforced with mineral fillers and glass fibres. The natural gypsum is mainly extracted from quarries in close vicinity to the manufacturing site. Furthermore, Knauf Fireboard is covered with glass fibre fleece. Additives are added for an easier processing and a fine adjustment of properties of Knauf Fireboard GM-F. These additives add up to less than 5 %.

Transport of raw materials (A2)

Natural gypsum is extracted from mines close to the manufacturing sites of Knauf Fireboard GM-F. Accordingly

transport distances are short and trucks can be used. Further raw materials are supplied by trucks and / or ocean-going ships depending on the country of origin.

Manufacturing (A3)

Natural gypsum is calcined prior to the mixing with other components. Stucco, mineral fillers and additives are mixed with water and processed as described in section 2.6. The addition of water allows the stucco to incorporate the water in its crystal lattice. By this process the gypsum sets and hardens. Redundant surface water is removed in a multi-level dryer.

Transport to the building site (A4)

For transport, a standard distance of 100 km by truck is assumed. This declaration facilitates the extrapolation of the results in A4 to the real distance.

Name	Value	Unit
Transport distance	100	km
Capacity utilisation (including empty runs)	60	%
Gross density of products transported	≥ 780	kg/m ³

Installation into the building (A5)

The installation in the building includes the electricity consumption for fastening the Knauf Fireboard GM-F using handheld power screwdrivers. Accessoires such as screws or the substructure itself are not part of the LCA in this EPD.

The packaging material, including defective re-usable wooden pallets and PE-straps, are incinerated. The credits from this process are reported in module D.

Name	Value	Unit
Electricity consumption	0.0018	kWh

Use phase (B1-B7)

Excluded since no environmental impacts/benefits are

expected. A service life of 50 years can be considered for gypsum plasterboards according to the Guideline for Sustainable Building BBSR2017.

End of life (C1-C4)

The demolition (C1) of Knauf Fireboard GM-F from the building is considered to be done 100% manually. It is assumed that the deconstruction would take place without further processing of the waste.

For the transport (C2) from the demolition site to the landfill by truck, a distance of 100 km was assumed in the calculation.

Name	Value	Unit
Collected separately waste type	16.4	kg
Landfilling	16.4	kg

Reuse, recovery and/or recycling potentials (D)

Module D contains only credits for exported energy from incineration of packaging material, such as defective re-usable wooden pallets and PE-straps (results only from A5).

5. LCA: Results

Factors for different thicknesses

The LCA results for Knauf Fireboard declared in this EPD refer to a product with a thickness of 20 mm. The following table enables the user of this EPD to calculate the results for different thicknesses. The LCA results in chapter 5 have to be multiplied by these factors.

Indicators	Factors for Knauf Fireboard 12.5 mm						Factors for Knauf Fireboard 15.0 mm						Factors for Knauf Fireboard 25.0 mm						Factors for Knauf Fireboard 30.0 mm					
	A1-A3	A4	A5	C2	C4	D	A1-A3	A4	A5	C2	C4	D	A1-A3	A4	A5	C2	C4	D	A1-A3	A4	A5	C2	C4	D
GWP-total	0,79	0,64	0,60	0,69	0,68	0,60	0,83	0,78	0,75	0,77	0,76	0,75	1,22	1,21	1,25	1,25	1,24	1,25	1,40	1,51	1,50	1,51	1,51	1,50
GWP-fossil	0,79	0,64	0,66	0,69	0,69	0,60	0,83	0,78	0,78	0,77	0,77	0,75	1,22	1,21	1,22	1,25	1,25	1,25	1,40	1,51	1,44	1,51	1,51	1,50
GWP-biogenic	0,57	0,64	0,60	0,69	0,62	0,60	0,73	0,78	0,75	0,77	0,68	0,75	1,25	1,21	1,25	1,25	1,15	1,25	1,50	1,51	1,50	1,51	1,32	1,50
GWP-luluc	0,52	0,64	0,85	0,69	0,69	0,60	0,72	0,78	0,90	0,77	0,77	0,75	1,25	1,21	1,10	1,25	1,25	1,25	1,40	1,51	1,19	1,51	1,51	1,50
ODP	0,37	0,64	0,85	0,69	0,69	0,60	0,66	0,78	0,90	0,77	0,77	0,75	1,27	1,21	1,10	1,25	1,25	1,25	1,39	1,51	1,19	1,51	1,51	1,50
AP	0,89	0,64	0,63	0,69	0,69	0,60	0,92	0,78	0,77	0,77	0,77	0,75	1,09	1,21	1,23	1,25	1,25	1,25	1,16	1,51	1,47	1,51	1,51	1,50
EP-freshwater	0,83	0,64	0,84	0,69	0,69	0,60	0,86	0,78	0,90	0,77	0,77	0,75	1,17	1,21	1,10	1,25	1,25	1,25	1,31	1,51	1,21	1,51	1,51	1,50
EP-marine	0,84	0,64	0,63	0,69	0,69	0,60	0,88	0,78	0,77	0,77	0,77	0,75	1,16	1,21	1,23	1,25	1,25	1,25	1,28	1,51	1,47	1,51	1,51	1,50
EP-terrestrial	0,84	0,64	0,62	0,69	0,69	0,60	0,88	0,78	0,76	0,77	0,77	0,75	1,14	1,21	1,24	1,25	1,25	1,25	1,25	1,51	1,48	1,51	1,51	1,50
POCP	0,84	0,64	0,62	0,69	0,69	0,60	0,89	0,78	0,76	0,77	0,77	0,75	1,13	1,21	1,24	1,25	1,25	1,25	1,24	1,51	1,47	1,51	1,51	1,50
ADPE	0,84	0,64	0,82	0,69	0,69	0,60	0,87	0,78	0,89	0,77	0,77	0,75	1,16	1,21	1,11	1,25	1,25	1,25	1,30	1,51	1,23	1,51	1,51	1,50
ADPF	0,80	0,64	0,71	0,69	0,69	0,60	0,83	0,78	0,82	0,77	0,77	0,75	1,21	1,21	1,18	1,25	1,25	1,25	1,39	1,51	1,37	1,51	1,51	1,50
WDP	0,90	0,64	0,60	0,69	0,69	0,60	0,92	0,78	0,75	0,77	0,77	0,75	1,09	1,21	1,25	1,25	1,25	1,25	1,16	1,51	1,50	1,51	1,51	1,50
PERE	0,85	0,64	0,60	0,69	0,69	0,60	0,88	0,78	0,75	0,77	0,77	0,75	1,16	1,21	1,25	1,25	1,25	1,25	1,30	1,51	1,50	1,51	1,51	1,50
PERM	0,60		0,60				0,75		0,75				1,25		1,25				1,50		1,50			
Pert	0,80	0,64	0,81	0,69	0,69	0,60	0,85	0,78	0,88	0,77	0,77	0,75	1,18	1,21	1,12	1,25	1,25	1,25	1,34	1,51	1,23	1,51	1,51	1,50
PENRE	0,80	0,64	0,71	0,69	0,69	0,60	0,83	0,78	0,82	0,77	0,77	0,75	1,21	1,21	1,18	1,25	1,25	1,25	1,39	1,51	1,37	1,51	1,51	1,50
PENRT	0,80	0,64	0,71	0,69	0,69	0,60	0,83	0,78	0,82	0,77	0,77	0,75	1,21	1,21	1,18	1,25	1,25	1,25	1,39	1,51	1,37	1,51	1,51	1,50
SM	0,00						0,98						1,20						1,30					
FW	0,80	0,64	0,61	0,69	0,69	0,60	0,83	0,78	0,75	0,77	0,77	0,75	1,20	1,21	1,25	1,25	1,25	1,25	1,36	1,51	1,49	1,51	1,51	1,50
HWD	0,38	0,64	0,69	0,69	0,69	0,60	0,66	0,78	0,81	0,77	0,77	0,75	1,27	1,21	1,19	1,25	1,25	1,25	1,39	1,51	1,39	1,51	1,51	1,50
NHWD	0,93	0,64	0,61	0,69	0,69	0,60	0,94	0,78	0,75	0,77	0,77	0,75	1,05	1,21	1,25	1,25	1,25	1,25	1,09	1,51	1,50	1,51	1,51	1,50
RWD	0,88	0,64	0,74	0,69	0,69	0,60	0,90	0,78	0,84	0,77	0,77	0,75	1,12	1,21	1,16	1,25	1,25	1,25	1,22	1,51	1,32	1,51	1,51	1,50
MFR			0,60						0,75															1,50
EEE			0,60						0,75															1,50
EET			0,60						0,75															1,50
PM	0,74	0,64	0,64	0,69	0,69	0,60	0,95	0,89	3,23	0,80	0,80	3,24	1,20	1,21	1,23	1,25	1,25	1,25	1,40	1,51	1,45	1,51	1,51	1,50
IR	0,90	0,64	0,70	0,69	0,69	0,60	0,93	0,89	3,00	0,80	0,80	3,59	1,10	1,21	1,19	1,25	1,25	1,25	1,18	1,51	1,38	1,51	1,51	1,50
ETF-fw	0,83	0,64	0,70	0,69	0,69	0,60	0,91	0,89	2,85	0,80	0,80	3,58	1,17	1,21	1,19	1,25	1,25	1,25	1,31	1,51	1,38	1,51	1,51	1,50
HTP-c	0,78	0,64	0,66	0,69	0,69	0,60	0,90	0,89	3,12	0,80	0,80	3,87	1,20	1,21	1,21	1,25	1,25	1,25	1,38	1,51	1,43	1,51	1,51	1,50
HTP-nc	0,81	0,64	0,66	0,69	0,69	0,60	0,88	0,89	2,77	0,80	0,80	3,36	1,18	1,21	1,22	1,25	1,25	1,25	1,33	1,51	1,43	1,51	1,51	1,50
SQP	0,66	0,64	0,76	0,69	0,69	0,60	2,94	0,89	2,53	0,80	0,80	3,59	1,23	1,21	1,15	1,25	1,25	1,25	1,45	1,51	1,30	1,51	1,51	1,50

DESCRIPTION OF THE SYSTEM BOUNDARY (X = INCLUDED IN LCA; MND = MODULE OR INDICATOR NOT DECLARED; MNR = MODULE NOT RELEVANT)

Product stage			Construction process stage		Use stage								End of life stage				Benefits and loads beyond the system boundaries
Raw material supply	Transport	Manufacturing	Transport from the gate to the site	Assembly	Use	Maintenance	Repair	Replacement	Refurbishment	Operational energy use	Operational water use	De-construction demolition	Transport	Waste processing	Disposal	Reuse-Recovery-Recycling potential	
A1	A2	A3	A4	A5	B1	B2	B3	B4	B5	B6	B7	C1	C2	C3	C4	D	
X	X	X	X	X	MND	MND	MNR	MNR	MNR	MND	MND	X	X	X	X	X	

RESULTS OF THE LCA - ENVIRONMENTAL IMPACT according to EN 15804+A2: 1 m² Knauf Fireboard GM-F

Parameter	Unit	A1-A3	A4	A5	C1	C2	C3	C4	D
GWP-total	kg CO ₂ eq	3.88E+00	6.62E-02	1.16E-01	0	1.42E-01	0	2.52E-01	-5.66E-02
GWP-fossil	kg CO ₂ eq	3.97E+00	6.33E-02	9.17E-03	0	1.36E-01	0	2.47E-01	-5.64E-02
GWP-biogenic	kg CO ₂ eq	-9.76E-02	2.92E-03	1.07E-01	0	6.29E-03	0	4.53E-03	-1.3E-04
GWP-luluc	kg CO ₂ eq	6.65E-03	1.51E-06	4.24E-06	0	3.24E-06	0	7.1E-04	-3.77E-05
ODP	kg CFC11 eq	7.58E-10	6.68E-18	5.13E-17	0	1.44E-17	0	9.15E-16	-5.58E-16
AP	mol H ⁺ eq	1.41E-02	6.33E-05	2.38E-05	0	1.36E-04	0	1.77E-03	-8.13E-05
EP-freshwater	kg P eq	4.64E-06	1.35E-08	7.23E-09	0	2.91E-08	0	4.24E-07	-7.11E-08
EP-marine	kg N eq	2.83E-03	2.01E-05	7.66E-06	0	4.33E-05	0	4.56E-04	-2.06E-05
EP-terrestrial	mol N eq	2.9E-02	2.24E-04	1.1E-04	0	4.82E-04	0	5.01E-03	-2.2E-04
POCP	kg NMVOC eq	8.05E-03	5.7E-05	2.08E-05	0	1.23E-04	0	1.38E-03	-6.04E-05
ADPE	kg Sb eq	5.64E-07	1.9E-09	7E-10	0	4.08E-09	0	2.22E-08	-5.11E-08
ADPF	MJ	6.14E+01	8.97E-01	4.72E-02	0	1.93E+00	0	3.24E+00	-9.35E-01
WDP	m ³ world eq deprived	2.41E-01	1.24E-04	1.61E-02	0	2.67E-04	0	2.59E-02	-5.79E-03

GWP = Global warming potential; ODP = Depletion potential of the stratospheric ozone layer; AP = Acidification potential of land and water; EP = Eutrophication potential; POCP = Formation potential of tropospheric ozone photochemical oxidants; ADPE = Abiotic depletion potential for non-fossil resources; ADPF = Abiotic depletion potential for fossil resources; WDP = Water (user) deprivation potential

RESULTS OF THE LCA - INDICATORS TO DESCRIBE RESOURCE USE according to EN 15804+A2: 1 m² Knauf Fireboard GM-F

Parameter	Unit	A1-A3	A4	A5	C1	C2	C3	C4	D
-----------	------	-------	----	----	----	----	----	----	---

PERE	MJ	5.71E+00	2.83E-03	1.33E+00	0	6.08E-03	0	4.24E-01	-1.98E-01
PERM	MJ	1.32E+00	0	-1.32E+00	0	0	0	0	0
PERT	MJ	7.03E+00	2.83E-03	1.38E-02	0	6.08E-03	0	4.24E-01	-1.98E-01
PENRE	MJ	6.14E+01	8.98E-01	4.72E-02	0	1.93E+00	0	3.24E+00	-9.36E-01
PENRM	MJ	0	0	0	0	0	0	0	0
PENRT	MJ	6.14E+01	8.98E-01	4.72E-02	0	1.93E+00	0	3.24E+00	-9.36E-01
SM	kg	6.71E-02	0	0	0	0	0	0	0
RSF	MJ	0	0	0	0	0	0	0	0
NRSF	MJ	0	0	0	0	0	0	0	0
FW	m ³	1.72E-02	5.07E-06	3.82E-04	0	1.09E-05	0	8.17E-04	-2.36E-04

PERE = Use of renewable primary energy excluding renewable primary energy resources used as raw materials; PERM = Use of renewable primary energy resources used as raw materials; PERT = Total use of renewable primary energy resources; PENRE = Use of non-renewable primary energy excluding non-renewable primary energy resources used as raw materials; PENRM = Use of non-renewable primary energy resources used as raw materials; PENRT = Total use of non-renewable primary energy resources; SM = Use of secondary material; RSF = Use of renewable secondary fuels; NRSF = Use of non-renewable secondary fuels; FW = Use of net fresh water

RESULTS OF THE LCA – WASTE CATEGORIES AND OUTPUT FLOWS according to EN 15804+A2: 1 m² Knauf Fireboard GM-F

Parameter	Unit	A1-A3	A4	A5	C1	C2	C3	C4	D
HWD	kg	5.23E-06	8.71E-11	3.88E-11	0	1.87E-10	0	4.94E-08	-3.23E-09
NHWD	kg	1.6E-01	9.18E-05	1.65E-03	0	1.97E-04	0	1.63E+01	-1.56E-04
RWD	kg	1.46E-03	9.64E-07	3E-06	0	2.07E-06	0	3.68E-05	-6.83E-05
CRU	kg	0	0	0	0	0	0	0	0
MFR	kg	0	0	1.49E-03	0	0	0	0	0
MER	kg	0	0	0	0	0	0	0	0
EEE	MJ	0	0	2.29E-01	0	0	0	0	0
EET	MJ	0	0	4.1E-01	0	0	0	0	0

HWD = Hazardous waste disposed; NHWD = Non-hazardous waste disposed; RWD = Radioactive waste disposed; CRU = Components for re-use; MFR = Materials for recycling; MER = Materials for energy recovery; EEE = Exported electrical energy; EET = Exported thermal energy

RESULTS OF THE LCA – additional impact categories according to EN 15804+A2-optional: 1 m² Knauf Fireboard GM-F

Parameter	Unit	A1-A3	A4	A5	C1	C2	C3	C4	D
PM	Disease incidence	3.25E-07	3.33E-10	1.32E-10	0	7.16E-10	0	2.19E-08	-7.28E-10
IR	kBq U235 eq	2.15E-01	1.38E-04	3.99E-04	0	2.96E-04	0	3.78E-03	-1.12E-02
ETP-fw	CTUe	9.76E+00	6.36E-01	2.06E-02	0	1.37E+00	0	1.85E+00	-1.98E-01
HTP-c	CTUh	5.53E-10	1.2E-11	1.2E-12	0	2.57E-11	0	2.74E-10	-7.74E-12
HTP-nc	CTUh	3.1E-08	5.12E-10	4.88E-11	0	1.1E-09	0	3.02E-08	-3.44E-10
SQP	SQP	1.94E+01	2.31E-03	1.6E-02	0	4.96E-03	0	6.75E-01	-1.43E-01

PM = Potential incidence of disease due to PM emissions; IR = Potential Human exposure efficiency relative to U235; ETP-fw = Potential comparative Toxic Unit for ecosystems; HTP-c = Potential comparative Toxic Unit for humans (cancerogenic); HTP-nc = Potential comparative Toxic Unit for humans (not cancerogenic); SQP = Potential soil quality index

Disclaimer 1 – for the indicator “Potential Human exposure efficiency relative to U235”. This impact category deals mainly with the eventual impact of low-dose ionizing radiation on human health of the nuclear fuel cycle. It does not consider effects due to possible nuclear accidents, occupational exposure or radioactive waste disposal in underground facilities. Potential ionizing radiation from the soil, radon and from some construction materials is also not measured by this indicator.

Disclaimer 2 – for the indicators “abiotic depletion potential for non-fossil resources”, “abiotic depletion potential for fossil resources”, “water (user) deprivation potential, deprivation-weighted water consumption”, “potential comparative toxic unit for ecosystems”, “potential comparative toxic unit for humans – cancerogenic”, “Potential comparative toxic unit for humans - not cancerogenic”, “potential soil quality index”. The results of this environmental impact indicator shall be used with care as the uncertainties on these results are high as there is limited experience with the indicator.

This EPD was created using a software tool.

6. LCA: Interpretation

In general, the highest environmental impacts of Knauf Fireboard GM-F result from the product stage A1-A3 with the exception of Non-hazardous waste disposed (NHWD). For this indicator, module C4 and the disposal of the boards at inert landfill leads to the highest overall contribution.

Within product stage module A1 has noticeable effects on many indicators. It dominates Ozone depletion potential (ODP) with approx. 100 % and Hazardous waste disposed (HWD) with approx. 99 %. Module A1 has significant effects on Water deprivation potential (WDP) with approx. 77 % and Radioactive waste disposed (RWD) with approx. 74 %. Transports (A2) have low impacts overall. Contributions to Acidification potential

(AP) (approx. 12 %), Eutrophication potential marine (EP-marine) (approx. 16 %), Eutrophication potential terrestrial (EP-terrestrial) (approx. 16 %) and Formation potential of tropospheric ozone photochemical oxidants (POCP) (approx. 15 %) should be mentioned. Manufacturing (A3) dominates Global warming potential fossil (GWP-fossil) with approx. 52%. Contributions of approx. 40 % to Abiotic depletion potential for non-fossil resources (ADPE) and approx 53 % to Abiotic depletion potential for fossil resources (ADPF) should be mentioned. Module A3 dominates the Use of net fresh water (FW) with approx. 56 %. Module A3 significantly contributes to Total use of renewable primary energy resources (PERT) with approx. 47 % and to Total use of non-renewable primary energy

resources (PENRT) with approx. 53 %.

The Non-hazardous waste disposed (NHWD) is dominated by disposal C4 with approx. 99 %. This was expected since there is no recycling at the end of life but a complete landfilling.

Transports in module A4 and C2 have minor impacts overall.

Some small credits given in module D result from the incineration and recycling of packaging only. The disassembled product is landfilled after disassembly.

7. Requisite evidence

7.1 Leaching (sulphates and heavy metals)

Gypsum board Knauf Fireboard GM-F shows a leaching behaviour typical for gypsum-based building products *Dre2006*. That is why disposal is only allowed in landfills from landfill category 1 in Germany *DepV2021*. Plasterboards Knauf Fireboard GM-F are classified in waterhazard class 1 (slightly water-hazardous) AwSV.

7.2 Radioactivity

According to *Report BfS 2012* and *RP 112* dose values and radon concentrations of gypsum-based building products are below 0.3 mSv/a. Thus, they can be used without restrictions.

7.3 VOC emissions

According to the emission test from Eurofins Product Testing A/S, no hazardous substances are emitted above permissible thresholds during use *Eurofins2021*.

Test after 3 days (limit value)

Name	Value	Unit
TVOC	≤ 10	mg/m ³
Total carcinogenes	< 0.01	mg/m ³

Test after 28 days (limit value)

Name	Value	Unit
TVOC	≤ 1.0	mg/m ³
TSVOC	≤ 0.1	mg/m ³
R-value (dimensionless)	≤ 1	-
Sum of VOC without NIK/LCI	≤ 0.1	mg/m ³
Formaldehyde	≤ 0.1	mg/m ³
Total carcinogenes	≤ 0.001	mg/m ³

VOC emission tests showed that Knauf Fireboard GM-F significantly undercuts the required thresholds.

8. References

Standards

DIN 18180

DIN 18180:2014-09: Gypsum plasterboards - Types and requirements

EN 520

EN 520:2004+A1:2009: Gypsum plasterboards - Definitions, requirements and test methods

EN 12664

EN 12664:2001: Thermal Performance of Building Materials and Products - Determination of Thermal Resistance by Means of Guarded Hot Plate and Heat Flow Meter Methods - Dry and Moist Products with Medium and Low Thermal

EN 13501-1

EN 15283-2:2008+A1:2009: Fire classification of construction products and building elements – Part 1: Classification using data from reaction to fire tests

EN 15283

EN 15283-1:2009 Gypsum boards with fibrous reinforcement - Definitions, requirements and test methods and the CE-marking

EN 15804

EN 15804:2012+A2:2019 + AC:2021: Sustainability of construction works - Environmental product declarations - Core rules for the product category of construction products

EN 15804

EN 15804:2012+A1 2013: Sustainability of construction works — Environmental Product Declarations — Core rules for the product category of construction products

ISO 9001

EN ISO 9001:2015: Quality management systems - Requirements

ISO 14025

EN ISO 14025:2011: Environmental labels and declarations — Type III environmental declarations — Principles and procedures

ISO 14044

EN ISO 14044:2006 + A1:2018 + A2:2020: Environmental management - Life cycle assessment - Requirements and guidelines

ISO 15686

BS DD ISO/TS 15686-9:2010-01-31: Buildings and constructed assets -- Service life planning - Part 1: General principles and framework

ISO 45001

EN ISO 45001:2018: Occupational health and safety management systems – Requirements with guidance for use

ISO 50001

EN ISO 50001:2018: Energy management systems – Requirements with guidance for use

Further References

AgBB

Evaluation procedure for VOC emissions from building products, Committee for Health-related Evaluation of Building Products, 2023

AwSV 18.04.2017

Verordnung über Anlagen zum Umgang mit wassergefährdenden Stoffen 1,2 (AwSV) 18.04.2017 vom Bundesministerium der Justiz

BBSR2017

Service life of building components for life cycle analyses acc. to the Sustainable Building Assessment System (BNB) -- Nutzungsdauer von Bauteilen für Lebens-zyklusanalysen nach Bewertungssystem Nachhaltiges Bauen (BNB) 2017-02-24 vom Bundesinstitut für Bau-, Stadt-, Raumforschung (BBSR)

BDSH2013

Bauschäden durch Hochwasser - Tipps für die Sanierung (Flood damage - tips for recovery), instruction sheet, Knauf Gips KG (editor), Iphofen, 2013, <http://knauf.com>

BImSchG

Act on the Prevention of Harmful Effects on the Environment Caused by Air Pollution, Noise, Vibration and Similar Phenomena (Federal Immission Control Act - BImSchG), Publication 2013-05-2017 (BGBl. I p. 1274), last amended 2015-08-31 (BGBl. I p. 1474)

CPR2011

Regulation (EU) No 305/2011 for construction products (CPR), Regulation (EU) No 305/2011 of the European Parliament and of the Council of 9 March 2011 laying down harmonised conditions for the marketing of construction products.

DepV2021

Verordnung über Deponien und Langzeitlager (Deponieverordnung – DepV), German regulation on landfills, last amended and supplemented: 2021-07-09

Dre2006

H. Drexler, Test report no. 1080556 AU-23572, Dorfner Analysenzentrum und Anlagenplanungsgesellschaft mbH, Hirschau, 11.01.2006 (originator: Bundesverband Gips e. V., Dr. H.-J. Kersten, Berlin)

ECHA-List

Candidate List of substances of very high concern for Authorisation from the European Chemicals Agency, published in accordance with Article 59(10) of the 2024-11-07 REACH Regulation; <https://echa.europa.eu/de/candidate-list-table>

EU/EFTA

European Union/European Free Trade Association (EU/EFTA) (with the exception of Switzerland); <https://www.efta.int>

Eurofins2021

VOC Emission Test Report for Knauf Fireboard 15 mm by the institute 'Eurofins Product Testing A/S in Galten- Denmark; 2021-10-29

EWC

European Waste Catalogue, established by Decision 2000/532/EC of European Commission

IBU 2021

Institut Bauen und Umwelt e.V.: General Instructions for the EPD programme of Institut Bauen und Umwelt e.V., Version 2.0, Berlin: Institut Bauen und Umwelt e.V., 2021 www.ibu-epd.com

IBU PCR Part A

Institut Bauen und Umwelt e.V.: Product Category Rules for Building-Related Products and Services Part A: Calculation Rules for the Life Cycle Assessment and Requirements on the Project Report according to EN 15804+A2:2019, version 1.1.1, 2021-09-02

IBU PCR Part B "Plasterboards"

Institut Bauen und Umwelt e.V.: PCR Guidance-Texts for Building-Related Products and Services Part B: Requirements on the EPD for Plasterboard, v5, 2021-08-21

LCA tool

BV Gips LCA tool, version 1.0 created by Sphera Solutions GmbH, IBU-BVG-202101-LT1-DE

Regulation (EU) No 305/2011

Regulation (EU) No 305/2011 for construction products (CPR), Regulation (EU) No 305/2011 of the European Parliament and of the Council of 9 March 2011 laying down harmonized conditions for the marketing of construction products

Regulation (EU) No 1272/2008

REGULATION (EC) No 1272/2008 OF THE EUROPEAN PARLIAMENT AND OF THE COUNCIL of 16 December 2008 on classification, labelling and packaging of substances and mixtures, amending and repealing Directives 67/548/EEC and 1999/45/EC, and amending Regulation (EC) No 1907/2006

Regulation (EU) No 528/2012

REGULATION (EU) No 528/2012 OF THE EUROPEAN PARLIAMENT AND OF THE COUNCIL of 22 May 2012 concerning the making available on the market and use of biocidal products.

Report BfS 2012

Natürliche Radioaktivität in Baumaterialien und die daraus resultierende Strahlenexposition Fachbereich Strahlenschutz und Umwelt Gehrcke, K.; Hoffmann, B.; Schkade, U.; Schmidt, V.; Wichterey, K; Bundesamt für Strahlenschutz Salzgitter, November 2012 <http://nbn-resolving.de/urn:nbn:de:0221-201210099810>

RP 112

Radiological Protection Principals concerning the Natural Radioactivity of Building Materials, 1999

TRGS 521

Technical Rules for Hazardous Substances No. 521: 'Demolition, reconstruction and maintenance work with biopersistent mineral wools', German Federal Institute for Occupational Safety and Health, 2008-02

TRGS 559

Technical Rules for Hazardous Substances TRGS 559: Mineral Dust, Edition: February 2010, Federal Institute for Occupational Safety and Health (editor), last amended and supplemented: GMBI 2011

TRGS 900

Technical Rules for Hazardous Substances TRGS 900: Occupational Exposure Limits, Edition: January 2006, Federal Institute for Occupational Safety and Health (editor), last amended and supplemented: GMBI 201

Technical brochures Knauf

Downloadable under <https://knauf.com>

Declaration of Performance

DoP_EN_15283-1_GM-F_0010_Knauf_Fireboard_20_2020-03-12.pdf

Safety Datasheet

SORG_0010_Fireboard_20_10084_0010_SDS_1.0_EU_en.pdf

Technical Datasheet

K7501_DSP.de Fireboard.pdf

VOC Emission Test

VOC15_ND.de VOC Emissionsmessung - Fireboard.pdf



Publisher

Institut Bauen und Umwelt e.V.
Hegelplatz 1
10117 Berlin
Germany

+49 (0)30 3087748- 0
info@ibu-epd.com
www.ibu-epd.com



Programme holder

Institut Bauen und Umwelt e.V.
Hegelplatz 1
10117 Berlin
Germany

+49 (0)30 3087748- 0
info@ibu-epd.com
www.ibu-epd.com



Author of the Life Cycle Assessment

Knauf Gips KG
Am Bahnhof 7
97346 Iphofen
Germany

0049 9001 31-1000 *
knauf-direkt@knauf.com
www.knauf.com



Owner of the Declaration

Knauf Gips KG
Am Bahnhof 7
97346 Iphofen
Germany

0049 9001 31-1000 *
knauf-direkt@knauf.com
www.knauf.com