



KNAUF IMPACTWALL™ SYSTEM

KNAUF

Build on us.



The construction industry is progressing rapidly. Innovative developers and architects are now specifying drywall construction for commercial and residential buildings as it is faster, lighter and safer than conventional construction methods and has better functional performances.

Gypsum-based drywall products and systems were developed in the US from the early 1900s and have been adopted predominantly in the residential construction industry in North America, Australasia, and Europe for decades. In Malaysia, the gypsum-based drywall systems have been widely used in the commercial segment. However, there is a rising trend of adopting this system in the residential segment in which developers can fully optimise its benefits.

The Knauf Impactwall™ System is constructed specifically for use in residential homes and stress tested for durability and resilience. Moreover, this system provides functional acoustic, fire-and moisture-resistant performance.

There are commercial buildings used by the public intensively which are prone to abnormally rough use and vandalism. Hospital corridors are particularly susceptible to knocks by trolleys and general traffic. Stretchers, wheelchairs, medical equipment, and furniture are all moved frequently and often in a hurry. Therefore, these areas are required to use the impact resistant lining materials. The Knauf Impactwall™ System meets the severe duty rating, which is the highest category of performance in the Strength and Robustness Test BS 5234 part 2.

Knauf's 102mm Impactwall™ System is constructed using high density, fire and moisture resistant gypsum boards, which is 100% recyclable. This system is ideally suited for high-traffic areas in hotels, and healthcare and residential interior environments. The Knauf Impactwall™ System combines fire rating and impact resistance qualities with an easily buildable and attractive finish.

KNAUF IMPACTWALL™ SYSTEM ADVANTAGES



High Impact Resistance

Severe Duty as per BS 5234 part 2 (Knauf Sheetrock® Impactstop™ 19mm for both sides + 64mm 0.5mm BMT Metal).



Better WiFi Coverage⁽¹⁾

Knauf Drywall is proven with excellent WiFi performance or coverage at higher bandwidths (2.4GHz vs 5GHz) across a larger floor space.



Better Acoustic Performance

STC : 46
**With 1 layer 19mm Knauf Sheetrock® Impactstop™ for both sides of wall, Knauf Insulation 16kg/m³, 50mm thickness.



Greater Floor Area

Knauf Impactwall™ System 102mm wall thickness offers more useable space and yet with high functional performances.



Aesthetics

Smooth surface for instant finishing. Electrical cabling and services can be accommodated within the wall cavity.



Non-Combustible and Fire Resistance

Knauf Sheetrock® Impactstop™ board is a non-combustible material. 1-hour and 2-hour fire rated systems are available.



Moisture-Resistant

Knauf Sheetrock® Impactstop™ board has less than 5% water absorption performance in accordance to BS EN520 standard.



Reduced Construction Time

Drywall is a fast track construction material, which is 3 to 4 times faster than conventional brick wall construction.



Lightweight

Knauf Impactwall™ System is 8 times lesser weight than conventional brick wall. It helps to reduce structural cost especially for high-rise buildings.

(1) Knauf contracted RUCKAS, a market leader in the supply of WiFi services, to simulate a typical hotel accommodation layout using different types of partition made from drywall and blockwall in order to map WiFi propagation across the floor. Detailed results available on request.

KNAUF IMPACTWALL™ SYSTEMS VS CONVENTIONAL WALL SYSTEMS

	Precast Panel	Brick	Knauf Impactwall™ System 1-Hour	Knauf Impactwall™ System 2-Hour
Weight	420kg/3m	900kg/3m	113kg/3m	144kg/3m
Thickness	100mm	100mm	102mm	140mm
Productivity	18 - 23m ² /man/day	4 - 7m ² /man/day	25m ² /man/day	20m ² /man/day
Sound Insulation	41 dB	35 - 40 dB	46 dB ⁽¹⁾	57 dB*
Fire Resistance Rating	1 Hour	2 Hours	1 Hour	2 Hours
Non-Combustibility	Pass	Pass	Pass	Pass
On-site Installation of Concealed Wiring, Ducting & Pipework	During installation of wall, services can be run through wall cell. After installation of wall, wall surface can be chased and avoided within wall filling with packing material.	By surface hacking	By fitting services before covering the face of the wall	By fitting services before covering the face of the wall
Surface Appearance	Smooth, with 3mm of skim coat.	Smooth, only with skilled plasterers.	Very smooth. No skim coat required.	Very smooth. No skim coat required.
Applied Finishes Tiling	Yes	Yes	Yes	Yes
Joint Treatment	Cementitious joint compound is applied between abutting panels. When dry, joint is tooled to form a 3mm groove and applied with a finishing compound.	Not applicable	Paper tape is used to seal joint, followed by application of joint compound.	Paper tape is used to seal joint, followed by application of joint compound.
Fasteners Type	Cavity Anchors	Plastic Plugs, Chemical Anchors, Impact Anchors	Cavity Anchors, Gypsum Screws	Cavity Anchors, Gypsum Screws
Flexibility of Relocation	Can be removed and replaced with relative ease and minimal mess.	Removal and replacement is very messy due to hacking and wet trade	Removal and replacement is fast and easy	Removal and replacement is fast and easy
Industrialised Building System (IBS)	Yes	No	Yes	Yes

*INSUL simulation

(1) With 1 layer 19mm Knauf Sheetrock® Impactstop™ for both sides of wall, Knauf wall stud 64mm x 0.50BMT @ 610 c/c, Knauf Insulation 16kg/m³, 50mm thickness.

STRENGTH AND ROBUSTNESS OF DRYWALL SYSTEM



Impact-Resistant Plasterboard

Impact resistance on walls typically takes into account collisions in the form of soft body, abrasive and hard body under the BS 5234 Part 2 tests. Knauf Sheetrock® Impactstop™ plasterboard forms heavy-duty systems that not only achieve heavy to severe-duty performance but can also be engineered to resist damage from door slamming and heavyweight anchorages of wash basins.

Knauf impact-resistant plasterboard can be used in areas such as corridors where a solid partition is desired as shown in the table below:

Drywall	Typical Occurrence	Description
Light Duty	<ul style="list-style-type: none"> • Areas with no or less crowd traffic 	<ul style="list-style-type: none"> • Small chances of accidents • People tend to exercise care
Medium Duty	<ul style="list-style-type: none"> • Business offices 	<ul style="list-style-type: none"> • Some chances of accidents and misuse • Spaces are moderately used • People tend to exercise some care
Heavy Duty	<ul style="list-style-type: none"> • Industrial areas • Public areas with light to medium crowd traffic 	<ul style="list-style-type: none"> • Chance of misuse and accident occurring • Areas are highly used • People tend to exercise minimal care
Severe Duty	<ul style="list-style-type: none"> • Heavy industrial areas • High-traffic public areas 	<ul style="list-style-type: none"> • Susceptible to vandalism with high chance of accident and misuse • High traffic with space being used extensively by public

The strength of a partition is judged by the ability to resist deflection under load or by the force needed to break through the partition when subjected to an impact by either a hard or soft body. The factors which control these aspects of acceptability are:

- | | | |
|--|--|--|
| 1 The bending strength of the frame | 5 The rigidity of the head and base fixing | 9 Any temporary point load (if any) at mid height |
| 2 Partition maximum height | 6 The spacings of the studs | 10 The stiffness of the plasterboard |
| 3 The thickness of the plasterboard | 7 The axial load (if any) from above | 11 The bending or breaking strength of the plasterboard |
| 4 The number of plasterboard layers | 8 The wind load – uniformly distributed load (UDL) (if any) | |

The main tests are:

- | | |
|---|---|
| 1 Stiffness
– 500N temporary pressure | 3 Large soft body impact
– 50kg swinging bag |
| 2 Small hard body impact
– 3kg swing hammer | 4 Door slamming
– 20 slams, 35kg door for LD and MD
– 100 slams, 60kg door for HD and SD |

From these tests, it is possible to judge whether the partition is graded as:

- Light duty LD
- Medium duty MD
- Heavy duty HD
- Severe duty SD

BS 5234 Part 2 - Performance Tables

Partition grades: Summary of requirements and principle test performance levels.

Requirements and Test Methods	Unit	Grade				Principle Criteria
		LD	MD	HD	SD	
Stiffness	mm	25	20	15	10	Maximum deflection Maximum residual deformation
	mm	5	3	2	1	
Small hard body impact: Surface damage	N.m	3	3	6	10	Judgement of incident
Perforation	N.m	(2)	5	15	30	No perforation on facing
Large body soft impact	N.m	20	20	40	100	2mm minimum deflection
Structural damage	N.m	60	60	120	120	No collapse or dislocation
Door slam	No.	20	20	100	100	No damage and 1mm maximum displacement

1. Test methods are shown by letters in brackets which refer to annexes in BS 5234 Part 2.
2. No requirements for this grade.

The following non-compulsory tests as part of BS 5234 Part 2 can also be conducted with consideration to the respective partition grading (Light Duty, Medium Duty, Heavy Duty or Severe Duty):

- | | |
|--------------------------------|--|
| 1 Crowd Pressure | – 0.75kN/m, 1.5kN/m or 3.0kN/m pressure |
| 2 Lightweight anchorage | – Pull Out Test (Static Pull Out Load of minimum 100N)
– Pull Down Test (Static Pull Down Load of minimum 250N) |
| 3 Heavyweight anchorage | – Wash Basin (Eccentric Cyclic Load of minimum 500N)
– Wall Cupboard (Incremental Load Step in the range of 2000N to 4000N) |

MAIN TESTS AS PER BS 5234 PART 2

1. Partition Stiffness Test

Objective: To determine maximum deflection and residual deflection of partition after point load was applied at 1.50m height.

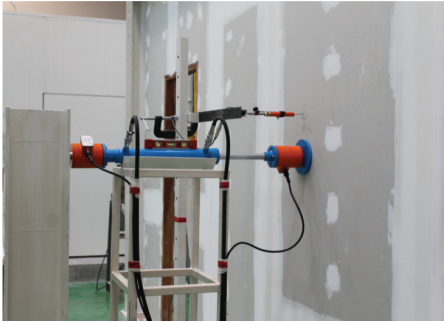

- 1 Apply point load on partition specimen, 1.50m height.
- 2 Magnitude of load varies with time according to BS 5234 Part 2.
- 3 Measure maximum deflection and residual deflection of partition.

2. Small Hard Body Impact

- Surface Damage
- Perforation

Objective: To determine extent of damage, and depth of indent of partition surface after impact by small hard object was applied.



- 1 Hammer hits partition specimen.
- 2 Measure diameter and depth of surface damage.

3. Large Soft Body Impact

- Resistance to surface damage
- Resistance to structural damage by multiple impacts

Objective: To determine extent of damage, and deformation of partition after impact by large soft object was applied.



- 1 Measure maximum deflection and residual deflection of partition.

ADDITIONAL REQUIREMENT PERFORMANCE LEVELS

1. Crowd Pressure Test – 0.75kN/m, 1.5kN/m or 3.0kN/m Pressure)

Objective: To determine maximum deflection and residual deflection of partition after contribute load was applied at 1.25m height.



- 1 Apply continuous load with steel beam 2.50m length at 1.25m height.
- 2 Magnitude of load varies with time according to BS 5234 Part 2.
- 3 Measure maximum deflection and residual deflection of partition.

2. Lightweight Anchorage

- Pull Out Test (Static Pull Out Load of minimum 100N)
- Pull Down Test (Static Pull Down Load of minimum 250N)

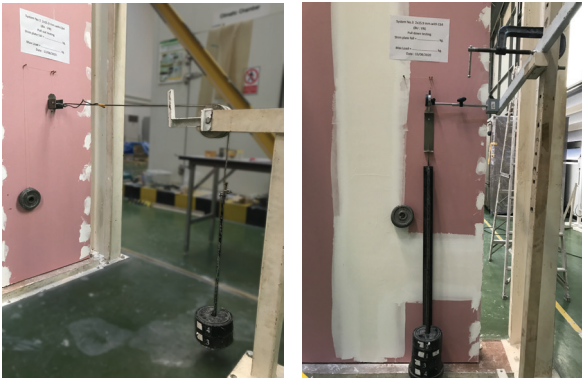

3. Heavy Weight Anchorage

Objective: To make sure that the partition specimen is able to withstand bending moment due to wash basin/wall cupboard application.



- 1 Apply point load in vertical direction to wash basin/wall cupboard frame.
- 2 Magnitude of load varies with time according to BS 5234 Part 2.
- 3 Measure maximum deflection and residual deflection of partition.

KNAUF SHEETROCK® IMPACTSTOP™

Knauf Sheetrock® Impactstop™ is manufactured from a specially formulated high density core encased in heavy face and strong back liner papers, with the unique ability to withstand damage caused by impact from various objects. Knauf Sheetrock® Impactstop™ meets the need for lightweight, fire, moisture and high-impact resistance solutions that are suitable for residential homes, hospitals, education centres, etc.

Features

- Higher density gypsum core provides additional protection recommended for severe duty applications as per BS 5234 Part 2 when assembled with Knauf metal framing system.
- Complies with international standards such as BS EN 520, or equivalent local standard for physical properties classification for gypsum boards, as well as BS 476 Part 6 & 7 for non-combustibility.
- Excellent acoustic properties when assembled in systems.
- Moisture-resistant and fire-resistant. It can be used in the approved systems to provide additional fire protection.



Property	Knauf Sheetrock® Impactstop™ 19mm
Weight (kg/m ²)	16.8
Thickness (mm)	19.0
Width (mm)	1220
Length (mm)	2440
Edges	Tapered
Face Paper Colour	Pink

*The above is standard size. Please refer to your Knauf representative for other board sizes.

Knauf Sheetrock® Impactstop™ complies with:

	Property	Test Methods	Specification	Knauf Sheetrock® Impactstop™ 19mm
Fire Reaction	Flexural Strength	BS EN 520	Parallel	>817N
			Perpendicular	>319N
	Non-combustibility Class O	BS 476 Part 6 & 7	Pass	Pass
Physical Properties	Water Absorption	BS EN 520	H1 (≤5%)	H1 (≤5%)
	Impact-resistant System Test (System Duty Rating Test)	BS 5234 Part 2	Severe Duty	Severe Duty
	Fire-resistant System Test	BS 476 Part 22	n/a	Yes

1-Hr Fire Rated Wall Systems

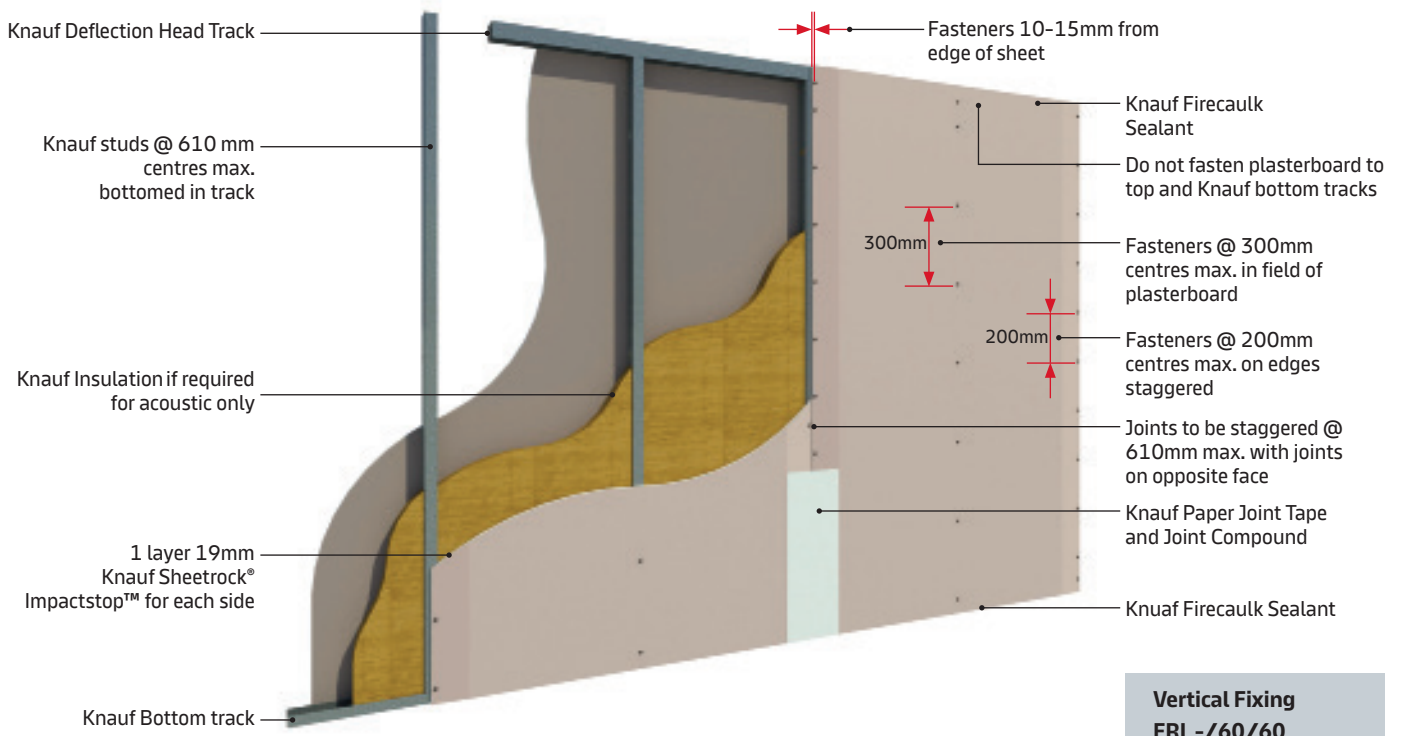

NOTE: Mid-span nogging is recommended for erection purpose in wall height than 4000mm.

2-Hr Fire Rated Wall Systems

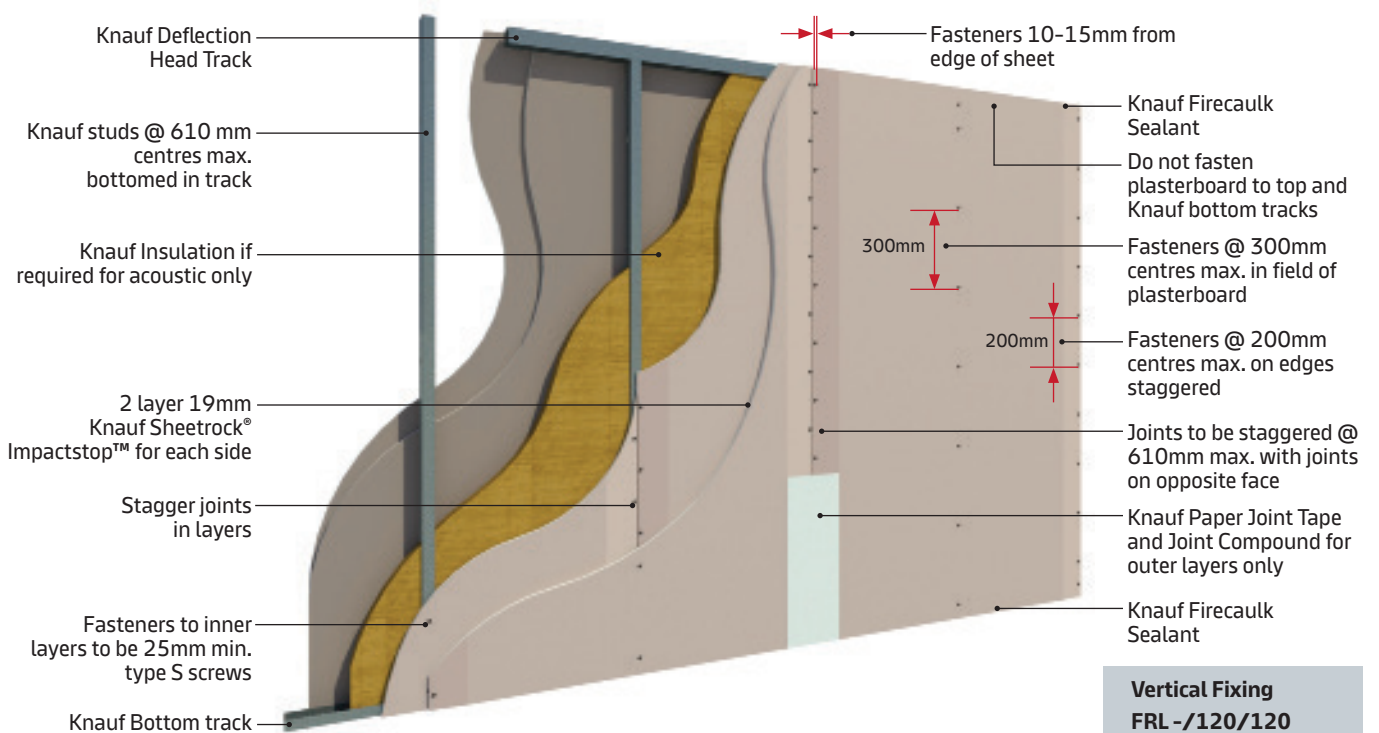

NOTE: Mid-span nogging is recommended for erection purpose in wall height than 4000mm.

INTERNAL DRYWALL FINISHING

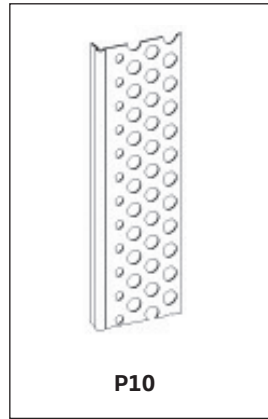
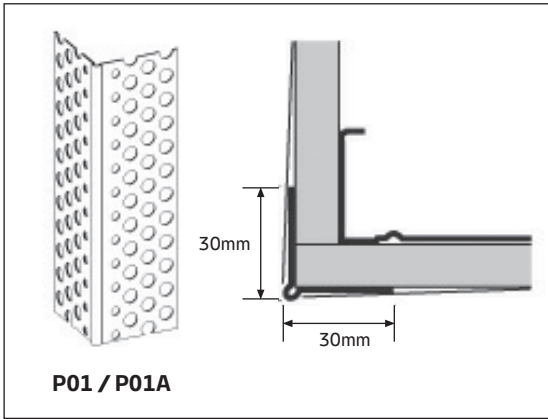

Perforated Sections & Detail

Property	Approx. Weight Per Lineal Metre (kg)	Material Thickness (BMT)	STD Lengths (m)
P01	0.155	0.35	2.4, 2.7, 3.0, 3.6 SA Only: 1.2, 2.12, 2.42
P01A	0.155	0.33	2.4, 2.7, 3.0, 3.6
P10	0.147	0.35	3.0

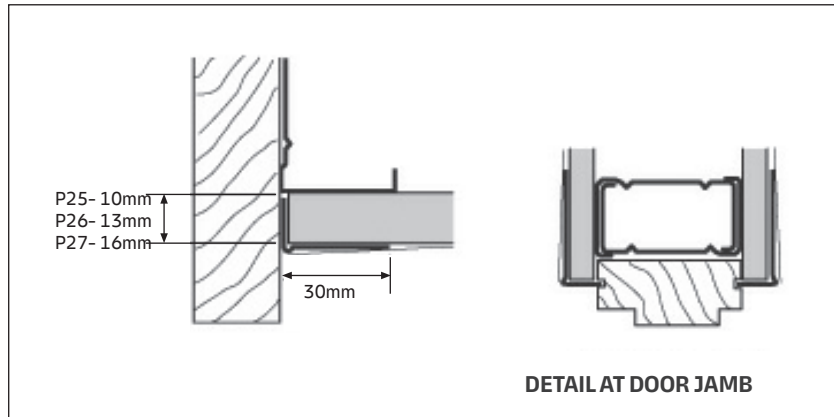
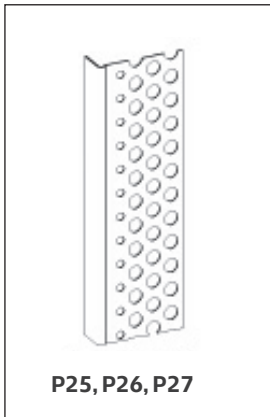

Stopping Angle

Stopping Angle: Detail at Door Jamb

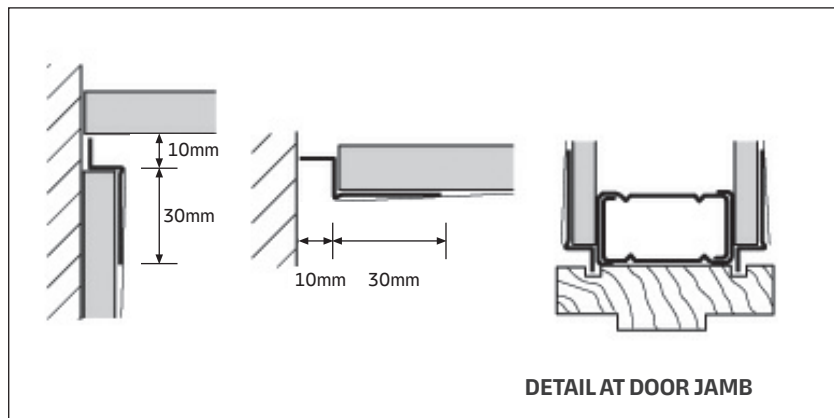
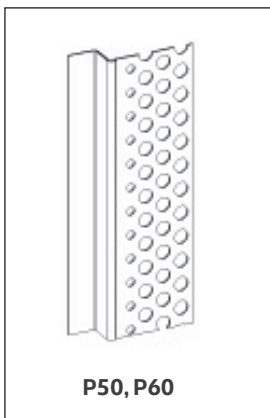

Shadowline Stopping Angle

Shadowline Stopping Angle: Detail at Door Jamb

Door Frame Details

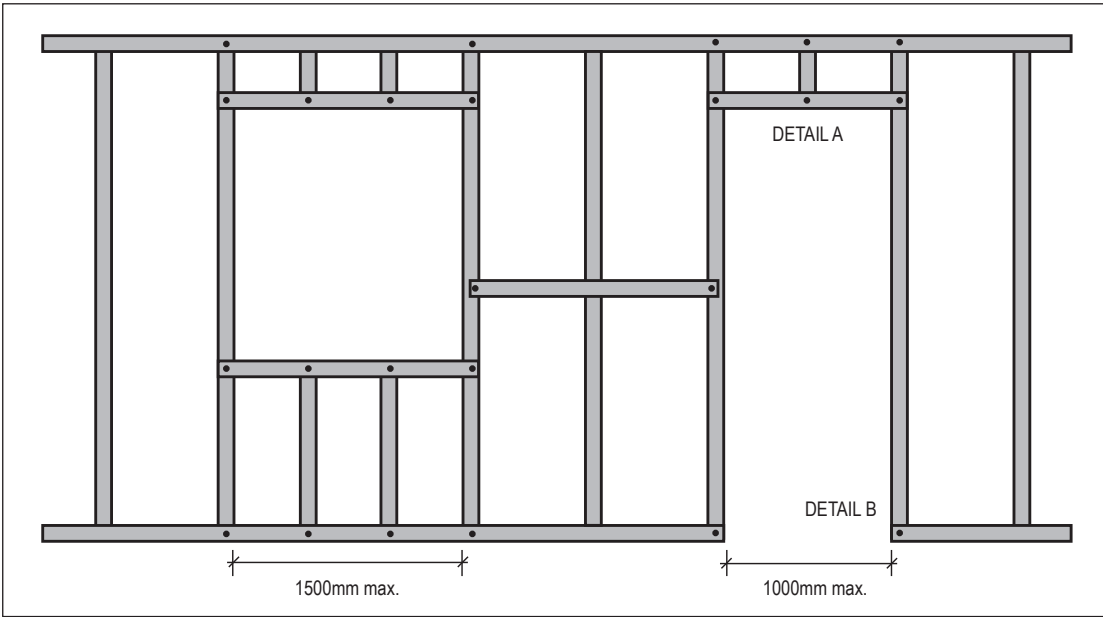

Internal Wall Framing

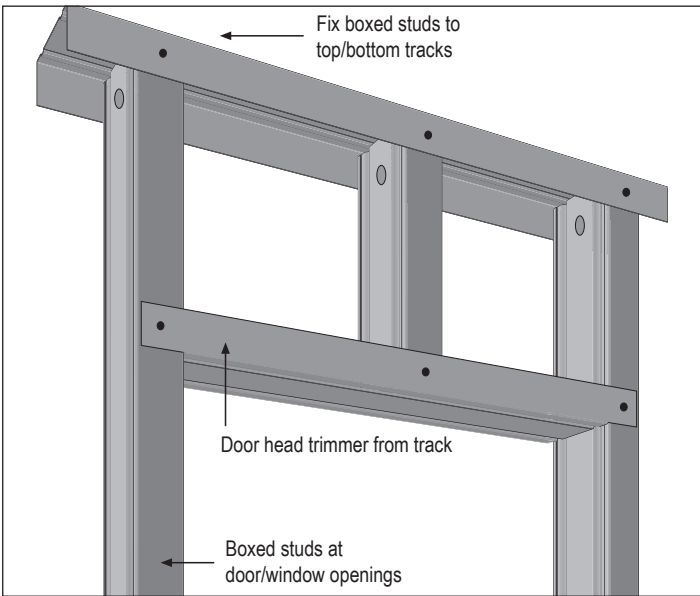

Detail A: Door/Window Head Detail

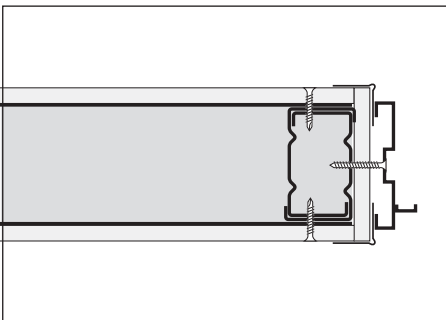

Detail B:
Extruded Aluminium
Door Jamb Profile

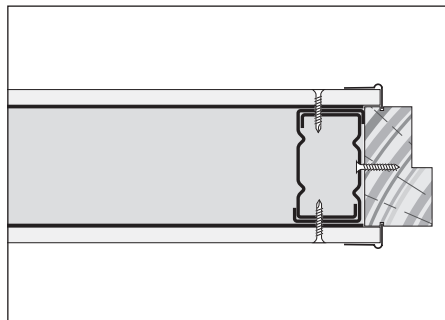

Detail B:
Timber Door Jamb with
Stopping Bead to Lining Board

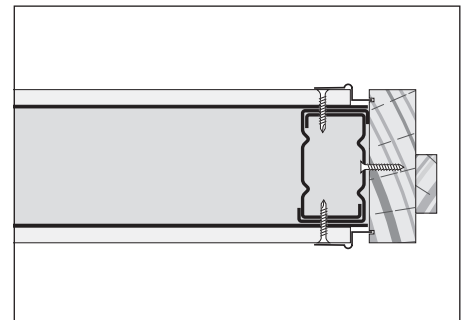

Detail B:
Timber Door Jamb with
Shadowline Detail

Door Jamb Detail

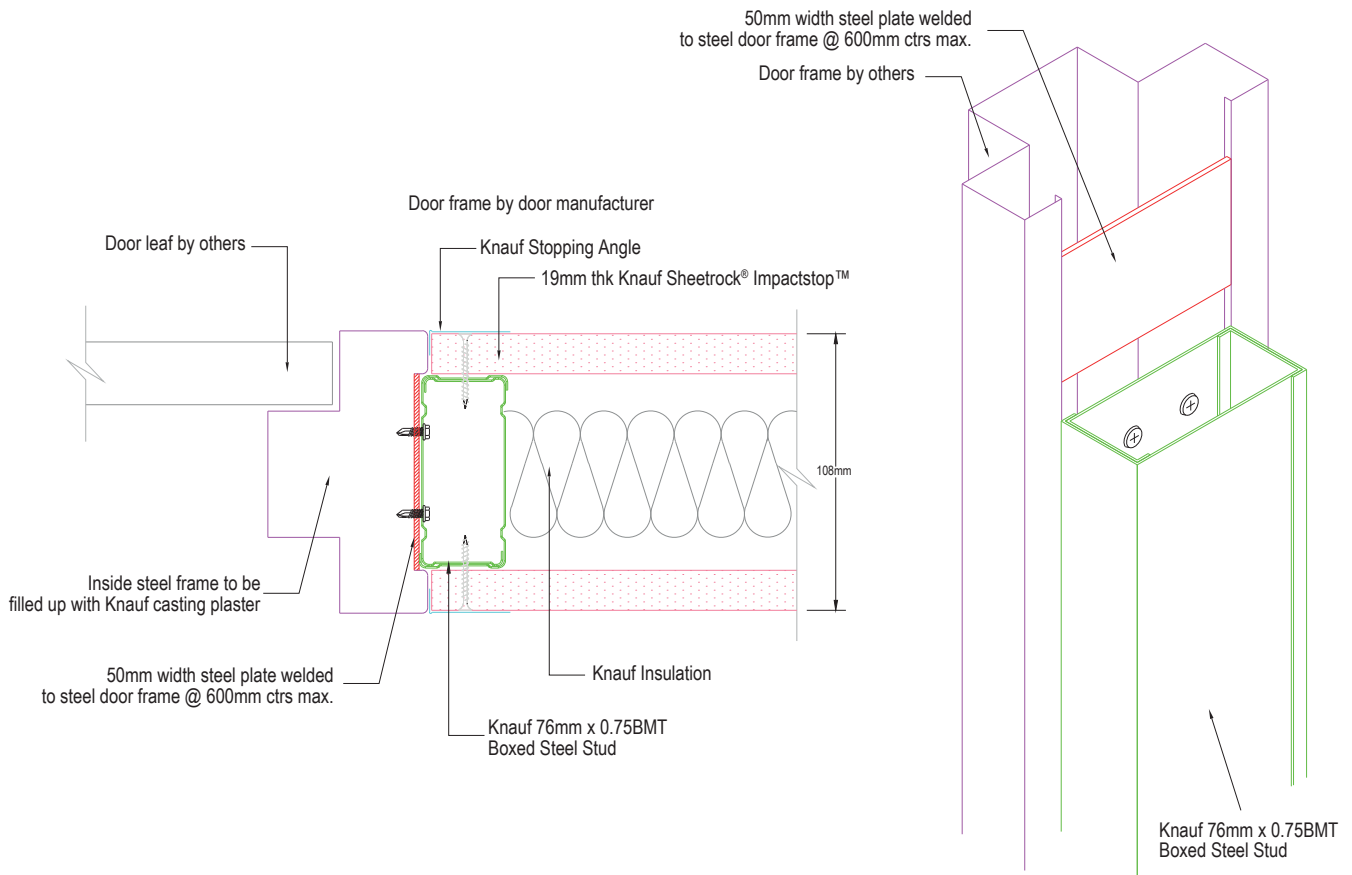

Door Jamb Detail (NTS)

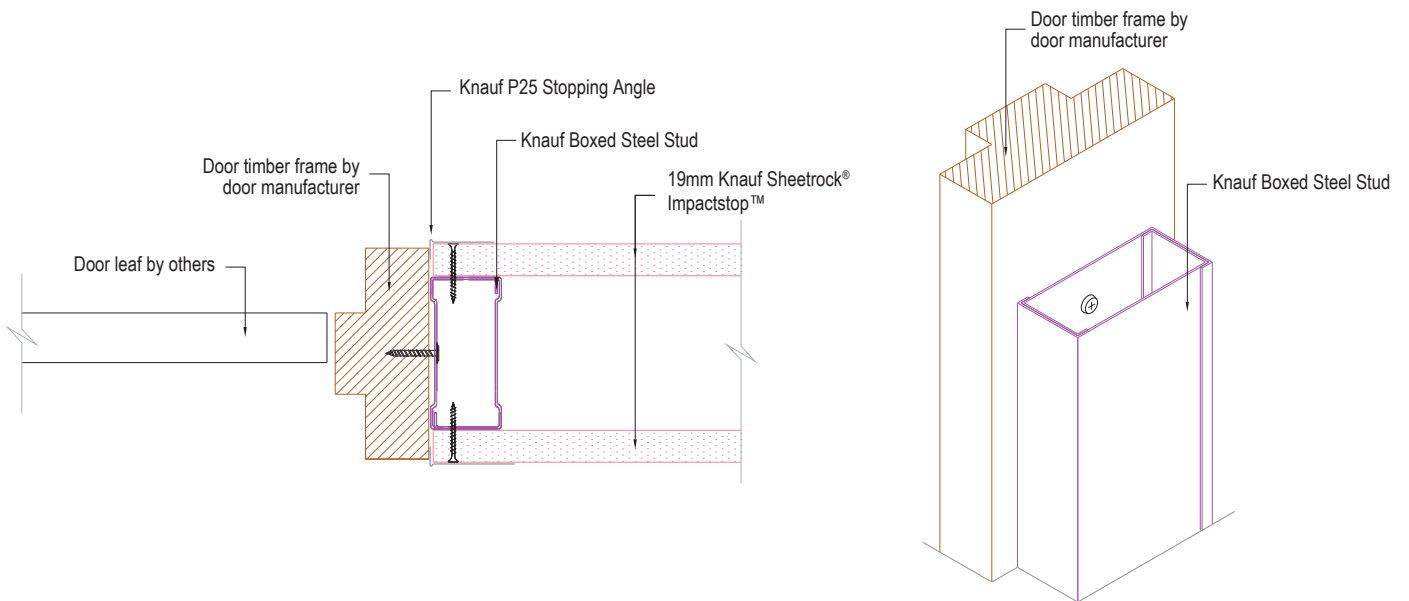

RESIDENTIAL PROJECT REFERENCES

Drywall in Residential Buildings



9 Bukit Utama Condo



Monash Residential Condo



Putrajaya Presint 16 (14 bungalow units)



Skysuites KLCC



St. Regis Residences



Four Seasons Private Residences



Tropicana Residences

© KNAUF 2021 and other third party copyright. All images shown are for reference purposes only. Any unauthorised reproduction is strictly prohibited.



Knauf Singapore Pte. Ltd.

79 Anson Road #07-01 Singapore 079906

T: (65) 6272 9272 E: contact-us.sg@knauf.com W: www.knauf.com

© 2024 KNAUF. All rights reserved. KNAUF and IMPACTSTOP are trademarks of Knauf Singapore Pte. Ltd. or one or more of its affiliates. SHEETROCK is a trademark owned by United States Gypsum Company and used under license. Information provided is for reference purpose only. Due care has been taken to ensure accuracy at time of publication. Products, specifications, and requirements may vary according to geographical locations and applications. As each project is unique, please contact your nearest Knauf representative for further assessment.

Scan to visit
our website



SG_PB39_CTG_0824_V1 P_SG_PB39_0824_01