



KNAUF

**MESH
CEILING
SOLUTIONS**

Installation Manual

Build on us.

Index

1 GENERAL INFORMATION

A	General Installation Conditions	6
B03	MESH General	14

2 SUSPENSION SYSTEMS

C01	T-Grid	20
C02	U-Profile	28
C04	Primary Angle	40
C05	DP12 A-Bar	44

3 EXPOSED GRID CEILINGS

D03.001	MESH Board / MESH MicroLook / MESH Tegular	T-Grid	52
D03.002	MESH R-L 201 / MESH R-L 201 MT	U-Profile primary grid	56
D03.002.1	MESH R-L 201 / MESH R-L 201 MT	Primary Angle primary grid	62
D03.002.2	MESH R-L 201 / MESH R-L 201 MT	Direct suspended	70
D03.003	MESH B-L 302 / MESH B-L 302 MT	U-Profile primary grid	78
D03.004	MESH B-H 300 / MESH B-H 300 MT	U-Profile primary grid	86
D03.004.1	MESH B-H 300 / MESH B-H 300 MT	Direct suspended	94
D03.005	MESH K-H 400 / MESH K-H 400 MT	Direct suspended	104

4 CONCEALED GRID CEILINGS

D03.100	MESH R-Clip	U-Profile primary grid	114
D03.100.1	MESH R-Clip	DP12 A-Bar primary grid	120
D03.100.2	MESH R-Clip	Direct suspended	126
D03.101	MESH R-H 200 / MESH R-H 200 MT	U-Profile primary grid	132
D03.101.1	MESH R-H 200 / MESH R-H 200 MT	Primary Angle primary grid	140
D03.101.2	MESH R-H 200 / MESH R-H 200 MT	Direct suspended	148
D03.102	MESH R-H 215 / MESH R-H 215 MT	U-Profile primary grid	156
D03.102.1	MESH R-H 215 / MESH R-H 215 MT	Direct suspended	162

5 FREE SPAN CORRIDOR CEILINGS

D03.400	MESH F-L 601 / MESH F-L 601 MT	Perimeter trim	170
D03.401	MESH F-Clip	Half DP12 A-Bar	178
D03.401.1	MESH F-Clip	DP12 A-Bar	186
D03.402	MESH F-H 600 / MESH F-H 600 MT	J-Bar	194

6 FLOATING CEILINGS - CANOPIES

E03.001	MESH Sonic Element MT	Direct suspended	204
E03.002	MESH Sky Element Hook MT	U-Profile primary grid	208

7 PERIMETER TRIMS & TRANSITIONS

T03.001	MESH Perimeter Solutions		216
T03.002	MESH Steel Bulkhead Solutions		220

8 CUTTING & MODIFICATIONS

U03	MESH Cutting & Modifications		232
-----	------------------------------	--	-----

9 MAINTENANCE & CLEANING

V03	MESH Maintenance & Cleaning		236
-----	-----------------------------	--	-----



MESH F-L 601

Stanley Black & Decker, Warsaw, Poland © Szymon Polański



General Information

General Installation Conditions

Brief overview

This installation manual replaces all previous documents. It contains information for specifiers and installers of suspended ceilings and wall applications.

Field of validity and application

The installation manual is to be regarded as an application standard and does not represent a complete reference to other existing standards. All statements and guidelines given concerning structural design refer exclusively to Knauf Ceiling Solutions products. It defines dimensions, tolerances on dimensions and necessary installation requirements for suspension and ceiling elements for interiors. In addition, the installer is obliged to observe any project-related specifications and individually applicable standard requirements. This installation manual is also in line with the guidelines provided in Annex A and Annex B of the suspended ceiling standard EN 13964.

For some areas, however, this installation manual is not valid. These are as follows:

- ceilings in means of transport
- heating and cooling ceilings
- air leakage
- thermal insulation
- ceilings with seismic requirements, except specific indicated solutions.
- ceilings subject to requirements regarding ingress of water
- ceilings for exterior applications, for which other extended requirements apply (tunnels, shelters, petrol stations, arcades, public sports facilities, car parks etc.), except specific indicated solutions.
- suspended ceilings or its supporting structure, on which you can walk
- ceilings with specific requirements for corrosion resistance, dynamic and/or static effects of loads (swimming pools, underground railway stations etc.)

For mountings of all kinds, the regulations documented here are to be observed.

All specifications and technical information in this manual or other publications referring to Knauf Ceiling Solutions products are based on test results, according to EN 13964. Technical modifications in the interest of improvements may be made by Knauf Ceiling Solutions at any time without prior notice.

The currently valid version can be obtained from Knauf Ceiling Solutions or can be downloaded directly from our website www.knauf.com.

Safety

Thin-gauged materials, particularly profiles and cut tile edges, are to be handled with due care in order to prevent injuries and damage. It is the obligation and full responsibility of the ceiling fixer to ensure sufficient safety.

Quality

Knauf Ceiling Solutions is certified in accordance with the ISO 9001 quality standard. For material properties, dimensional accuracy and coloration, our quality standard shall apply.

The installer is responsible for the quality of the finished ceiling, carried out according to the installation instructions shown in this document.

Fire protection

Knauf Ceiling Solutions delivers suspended ceiling components, which can be assembled and form fire protective barrier. Ceiling components have to be assembled in accordance with relevant classification report and country-specific and must comply with the requirements in accordance with EN 13501-1 (Reaction to fire), EN 13501-2 (Resistance to fire) and the country-specific standards and regulations.

Corrosion

In their standard version, Knauf Ceiling Solutions Suspension components are made of galvanised sheet steel or aluminium and thus protected against corrosion in accordance with EN 13964, provided that they are not exposed to any extreme corrosive atmospheres or emissions and the corrosion protection is not damaged during installation or the assembly of parts not supplied by Knauf Ceiling Solutions.

If it is evident from the design that contact corrosion can occur between different materials, this is to be pointed out by the planner and appropriate protective measures defined in accordance with EN ISO 12944-3 point 5.10.

To counteract the danger of condensation forming in ceiling cavities, sufficient rear ventilation of the ceiling construction is to be ensured. It is always advisable to consult a specialist.

General Installation Conditions

A

Statics

In terms of their load-bearing capacity and fitness for use (deflection), all systems documented in the installation instructions are statically tested and documented. Technical documentation of loadbearing elements is in accordance with the valid European Standard EN 13964. Please specify the desired, permitted deflection e.g. EN13964, class 1-3 in advance.

Additional loads are not provided for in their standard version. Apart from that of the dead load, the system constructions described have no load-bearing capacity for other components and are to be attached to supporting components. Neither the suspension nor the top layer must be walked on. The customer is responsible for defining the relevant additional loads and their written documentation.

Material expansion

The expansion of the ceiling construction as a result of temperature fluctuations due to exposure to direct sunlight or the failure of the air conditioning system is usually unproblematic. With very large ceiling areas and different material expansion coefficients, however, this may lead to issues.

Special attention should be paid here to wall joints and, if necessary, expansion joints. Careful, detailed planning and accurate installation are therefore all the more important.

Transport and storage

During transport and subsequent storage, the elements should be protected from moisture, high humidity and weather. Plastic packaging is not waterproof.

Attention should be given to the underlying surface which should be clean, dry and flat (full surface support) to avoid soiling or damage. Elements from different production dates / batches should not be installed within the same area. Recognisable, visibly damaged and broken parts (tiles, profiles, accessories, etc.) must not be installed.

Handling

It is essential to carefully handle both full cartons as well as individual elements, in accordance with workplace safety standards. They must not be thrown, dragged, pushed or slid across the floor. Cartons and elements should not be stood or turned on their corners or edges. No heavy objects should be placed on the cartons. Even short-term external influences can lead to damage. We recommend that any risks that may arise from this type of handling are carefully assessed.

To remove the elements, the packaging should be opened and removed all the way around. Individual elements should be handled carefully, preferably using suitable, clean installation gloves (white material).

Installation conditions

Knauf Ceiling Solutions elements should only be installed once all wet trades have been completed, building is sealed with doors and windows fitted and the room completely dried out. The heating system should be in operation in order to ensure a working temperature of 15 - 20°C. Before starting the installation, we recommend taking measurements with regards humidity and temperature. It is not recommended to start the installation if the relative humidity is over 70%.

During the subsequent period of use, the relative humidity may not exceed 90% or 95% depending on the type of tile used (see product data sheet).

In rooms with continually high relative humidity, special provisions should be made (see installation guidelines for wet rooms and swimming pools).

Improper handling and lack of observation of the installation conditions invalidates all warranties.

Installation

The individual installation company is responsible for correct, perfect installation as well as observance of the system standards specified here. Knauf Ceiling Solutions products and systems should only be installed by qualified and experienced fixers in order to maintain the high product quality of the Knauf Ceiling Solutions products. Any materials that are visibly damaged or exhibiting recognisable optical or technical impairments must not be installed. In this case, please contact Knauf Ceiling Solutions.

Fixings

The fixing of the perimeter trim to adjacent walls as well as the installation of the hangers and cross bracing should be carried out with appropriate and approved fixings (by others). As this is dependent on what material is being fixed to, the choice of fixing should always be carried out in consultation with the fixing manufacturer and approvals (ETA: European Technical Approval).

General Installation Conditions**A****General installation sequence**

- 1 Read the Knauf Ceiling Solutions installation instructions carefully.
- 2 Check the ceiling layout drawings or installation sketch based on the actual building conditions.
- 3 Determine the location and layout of ceiling elements (Main Runners and Cross Tees / primary and secondary grid, etc) according to instructions.
The position of the service integrations must also be taken into account.
- 4 Construction site equipment (scaffolding, assembly area, ladders, power connection, etc.).
- 5 Check the soffit and walls for the appropriate type of fixings.
- 6 Attach perimeter trims to the walls at the specified height / level. Depending on the construction of the walls, choose the appropriate type of fixings. For perimeter solutions see separate datasheet.
- 7 Determine the grid direction and mark suspension points on the structural soffit in the exact module dimensions.
The suspension and profile distances must be as specified.
- 8 Align the grid system according to the specifications and fix to the structural soffit with the selected suspension method. Check the squareness.
- 9 Install the ceiling elements. At the perimeter, the ceiling elements have to be cut to size on site.
- 10 In the course of installing the ceiling elements, the service integration components must also be installed.
Heavy service integrations must be suspended separately.
- 11 Align ceiling elements with precise joints and clean any soiled areas as specified.
- 12 Ceiling acceptance by construction management.

General Installation Conditions

A

Recommended layout for square tiles

Layout 1 - Not recommended

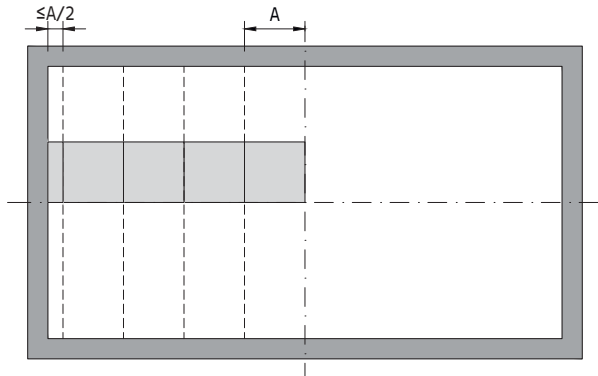

Layout 2 - Not recommended

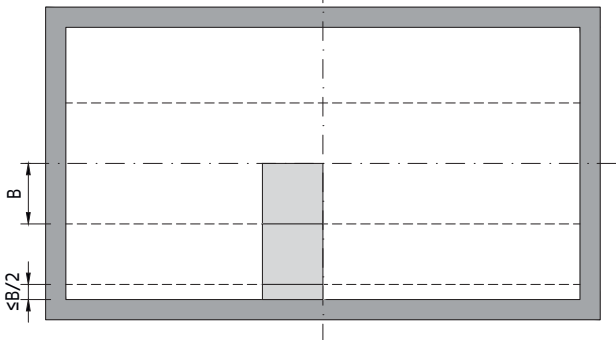

Layout 3 - Recommended

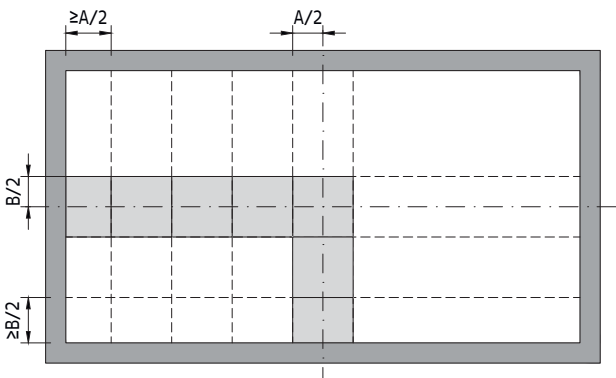

Layout 1 / 2

The ceiling is set out from the middle of the room in modules. In the example shown, the cut tile at the perimeter is very small.

Tile length (A) = tile width (B)

If the cut tile is less than half the tile length (A) or width (B), the layout is not recommended and should be avoided. In addition to requiring more profiles, small cuts appear aesthetically poor. If layout 1 and / or 2 does not provide the desired visual appearance (small tile cuts), layout 3 should be chosen.

Layout 3

Ceilings with larger cut tiles are aesthetically more pleasing and are more efficient to install. When setting out the ceiling, start from the middle. Ideally the first tile should be directly on the centre line (half the tile each side of the centre) unless this results in a small perimeter cut in which case align the tile edge with the centre line.

The layout then continues in the other direction.

General Installation Conditions

A

Recommended layout for rectangular panels

Layout 1 - Not recommended

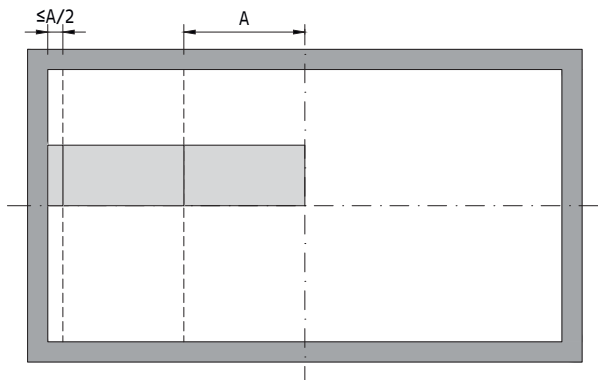

Layout 2 - Not recommended

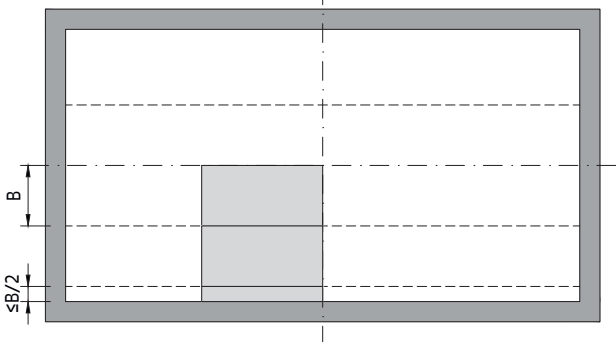

Layout 3 - Recommended

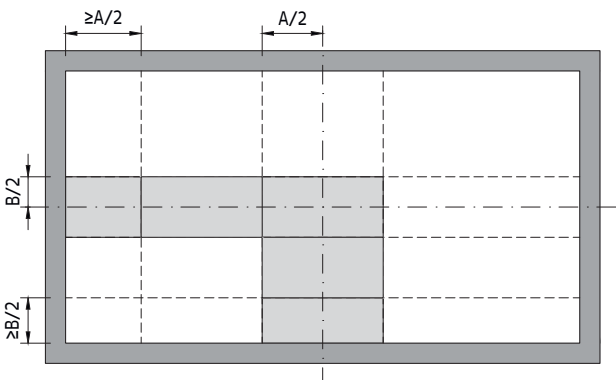

Layout 1 / 2

The ceiling is set out from the middle of the room in modules. In the example shown, the cut panel at the perimeter is very small.

Panel length (A), panel width (B)

If the cut panel is less than half the panel length (A) or width (B), the layout is not recommended and should be avoided. In addition to requiring more profiles, small cuts appear aesthetically poor. If layout 1 and / or 2 does not provide the desired visual appearance (small panel cuts), layout 3 should be chosen.

Layout 3

Ceilings with larger cut panels are aesthetically more pleasing and are more efficient to install. When setting out the ceiling, start from the first panel should be directly on the centre line (half the panel each side of the centre) unless this results in a small perimeter cut in which case align the panel edge with the centre line.

The layout then continues in the other direction.

General Installation Conditions

A

Recommended layout for linear grid

Layout 1 - Not recommended

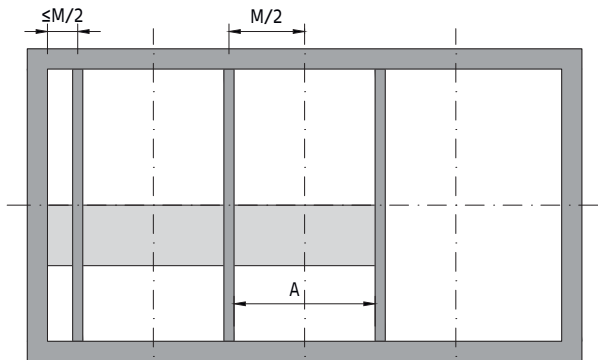

Layout 2 - Not recommended

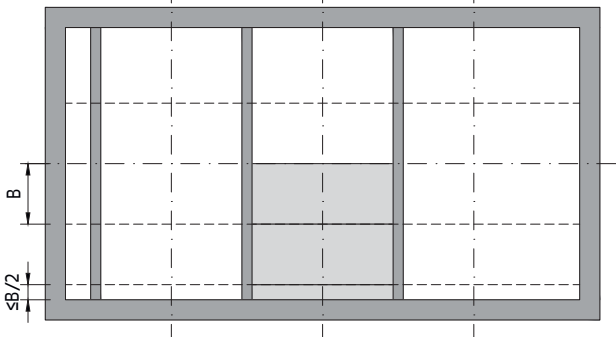

Layout 3 - Recommended

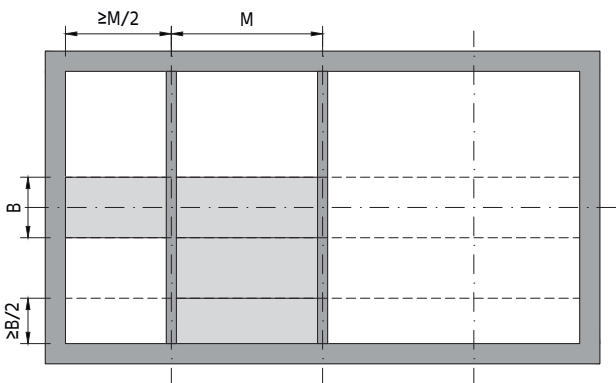

Layout 4 - Guide string / angled rooms and walls

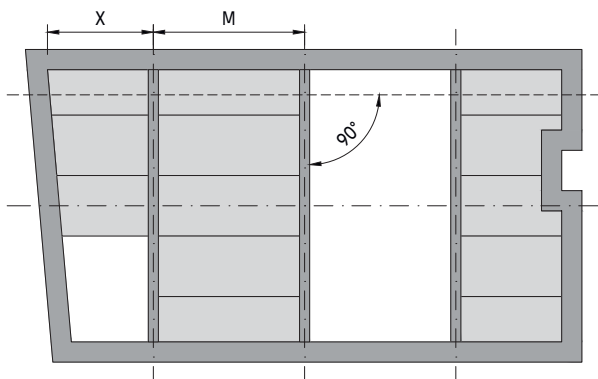

Bandraaster module

Each element has an overlay on the Bandraaster. The overlay depends on the selected ceiling system. See individual document for more information.

C-Profile module

Since the plates sit between the profiles, the C-Profile width must be subtracted to get the correct panel length (A).

Module length (M), panel length (A), panel width (B)

Layout 1 / 2

If the cut panel is less than half the module length (M) or width (B), it could appear aesthetically poor and is therefore not a recommended layout.

Layout 3

Usually the building center dimension specifies the alignment. The ceiling layout follows this modularisation.

If the layout of the building allows it, it is aesthetically more pleasing and more efficient to install a ceiling with larger cut panels. This will result in a cut panel length greater than half the module length (M) and therefore a correct layout.

Layout 4

As the rest of the installation follows the first panel, special care should be taken to ensure its correct installation. In order that the joints are aligned with the Bandraaster, it is helpful to span a guide string or laser level across the entire room's length. Starting from this reference line, the panels are cut to fit. It is usually enough to measure the width adjacent to the linear grid and then transfer it to the panel to be cut (the element width should be measured in two places). This can then be cut accordingly. The guide string can help to achieve a parallel joint pattern. Wall unevenness can also be better compensated for. Should the cut panels meet with an angled wall, the longest side (X) should equal the panel length; otherwise the layout should be adjusted.

General Installation Conditions

A

Recommended layout for baffles

Layout 1 - Not recommended

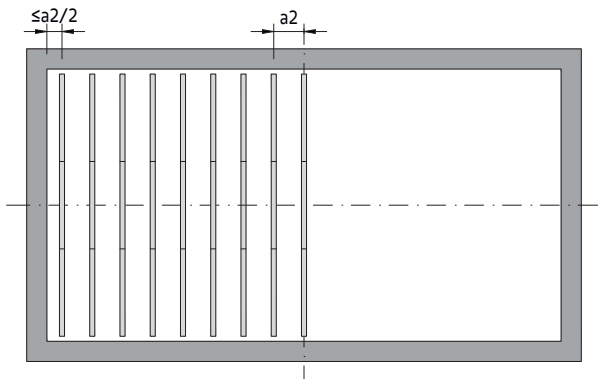

Layout 1

Starting from the middle of the room, the layout continues in baffle distances of ($a2$). The example shown results in a very small distance between the last baffle and the wall. If the last baffle distance to the wall is smaller than half ($a2$), the layout is not recommended for optical reasons.

Layout 2 - Not recommended

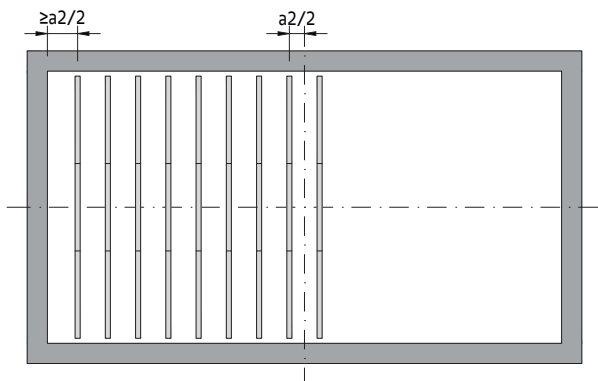

Layout 2

It is aesthetically more pleasing and more efficient to install a baffle ceiling with a larger distance between the last baffle and the wall. If, as described above, the baffles are set out from the middle of the room but results in an unfavourable layout, the baffle layout should be moved over by half of a distance ($a2$). This always results in a baffle distance to the wall larger than half a distance ($a2$).

Layout 3 - Recommended

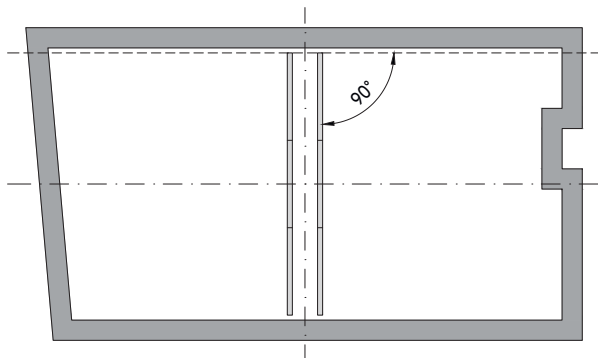

Layout 3

In order that the baffles are aligned in one row, it is helpful to span a guide string or laser level across the entire room's length. Starting from this reference line, the baffles can be aligned in long direction. The guide string can help to achieve a parallel layout. Wall unevenness can also be better compensated for.

General Installation Conditions

A

Canopy layouts

Where available, positioning devices provided in the packaging can simplify the alignment of the floating ceilings. Especially with non-rectangular shapes, such as circular, etc

Recommended layout for corridors

Layout 1 - Not recommended

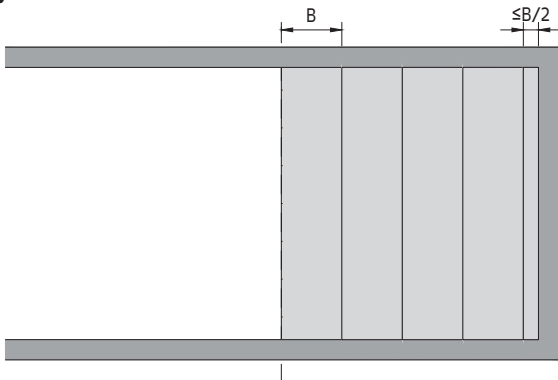

Layout 1

Starting from the middle of the corridor, the layout continues in element widths (B). The example shown results in a very small cut panel width (B). If the last cut panel is smaller than half a panel width, the layout is not recommended for optical reasons. If layout 1 does not provide the desired visual appearance (small panel cuts), layout 2 should be chosen.

Layout 2 - Recommended

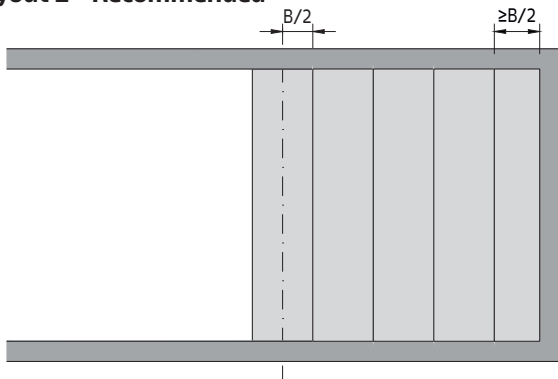

Layout 2

It is aesthetically more pleasing and more efficient to install a ceiling with larger cut panels. If, as described above, the ceiling is set out from the middle of the corridor but results in an unfavourable layout, the ceiling layout should be moved over by half a module width. This always results in a cut panel larger than half a panel width (B).

MESH General information

Base material

Material composition

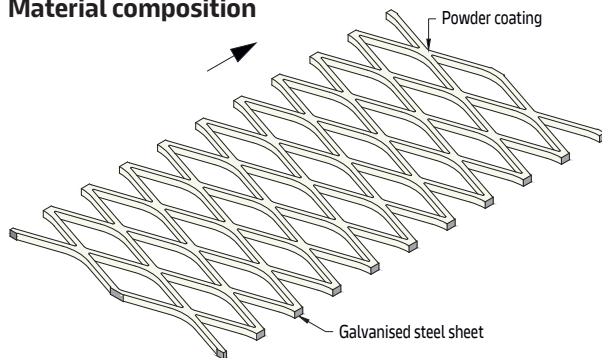

The mesh ceiling solutions from Knauf Ceiling Solutions are generally offered in galvanised steel. Some of the products can be made of aluminum on request. The material thickness depends on the selected mesh pattern. Square tiles are manufactured with a gauge of 1.0 mm, rectangular panels with 1.0 - 1.5 mm.

Surface/coating

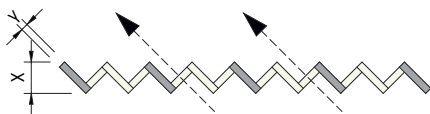

The standard finish is a high quality powder coating. A selection of popular colours is offered, other colours are available on request. By default, the visible side is coated, including edges that are defined as visible. All other surfaces are not supplied fully coated, which applies to the back and non-exposed edges. Depending on the direction of the mesh pattern, the surface has different shades of colour, which is due to the shadow play. This means that the surface can appear light and dark grey, for example, depending on which side you are looking at it from. Small colour differences can occur between the mesh elements and the profiles, wall angles, etc. Since the surfaces can yellow over time, subsequent items may show a colour difference. A low gloss level is recommended, otherwise reflections will make the ceiling appear more restless and the sagging of the elements will be emphasised (pillow effect), especially on smaller patterns. Whenever the coated surfaces are touched, this should always be done with soft white gloves, otherwise fingerprints will be left on the surface, which makes cleaning more time consuming.

Patterns

As a typical feature, mesh ceilings show a high open area surface. This is part of the design and can be used for ventilation / air circulation. Mesh products are directional, which has to do with the manufacturing process. The mesh direction is specified in the data sheets and runs in the longitudinal direction of the panels. Symmetrical products can therefore only be laid in one direction. Depending on the viewing direction, the surface either appears closed or open and then you can see everything behind it. This must be taken into account during planning and designed in such a way that the desired effect is achieved. Due to the expansion process, the surface has a three-dimensional appearance and gives the product an industrial look. There is a difference between the gauge of the raw material and the finished mesh pattern.

X = Mesh thickness

Y = Material gauge

MESH General information

B03

Dimensions / deflection / tolerances

1 Lay-in with square tiles

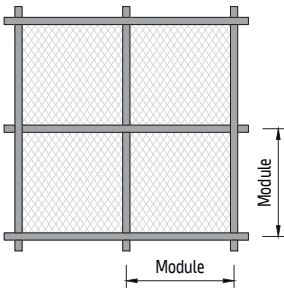

Square and rectangular tiles are specified in modular dimensions, such as 600 x 600, 625 x 625, 1200 x 600 mm. These are the distances between the T-grid (1).

With configurable rectangular panels in the Vario Design range, a distinction must be made between module size and actual dimensions (manufacturing size).

Example: Ceiling module size 2000 x 400 mm
 (2) Clip-in / hook-on with gap = 1997 x 397 mm
 (3) Linear with C-profile 100 mm + gap = 1894 x 397mm
 This logic is applicable to all systems and products shown in the this literature.

2 Clip-in / hook-on with rectangular panels + gap

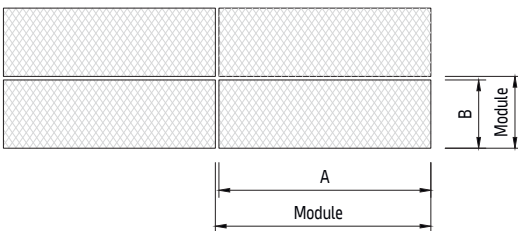

When planning and ordering, the rectangular panel (4) is shown as reclined from the rear side, with the long side C at the top, the long side D at the bottom, the short side E on the left and the short side F on the right. This allows each side to be uniquely defined. The upstands with the reinforcement angles on the long sides C / D are responsible for the stability of the panel and therefore for the flatness of the ceiling.

3 Linear grid with rectangular panels + gap

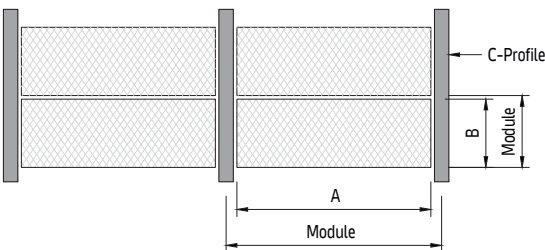

Large panels have an increased risk of being damaged during transport, handling and installation. Therefore, it is recommended not to exceed the specified limits. The panel width in particular is critical, as this is responsible for increased deflection in the center of the panel. If less deflection is desired, the panel width should be kept narrow. Reduce the width and use two panels instead of one wide one, if possible. Large panels can show a deflection on the long edges, up to 2 mm.

4 Rectangular panel parameters

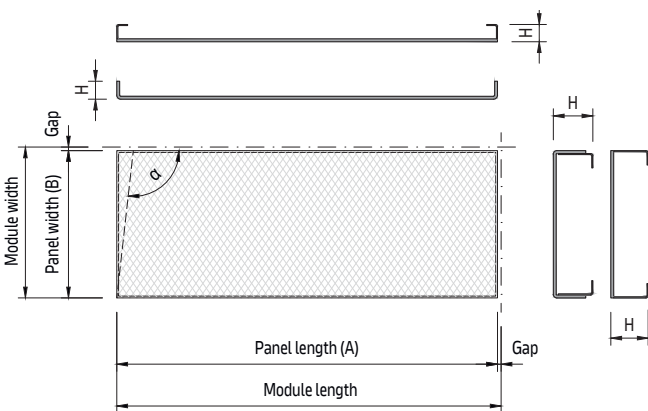

The larger the panel and the selected mesh pattern, the bigger the potential tolerances in bending and welding. The tolerances can vary from panel to panel, which is linked to the mesh pattern and welding process. Mesh panels always show a minus tolerance, which ensures the element fits into the modulation of the grid system. The panels are designed so that they can be installed at any time, but cannot fall out. With systems such as for example MESH R-H 200, where the panels are hooked-on a concealed grid, the shadow effect and larger joints caused by the tolerances can be more visible using smaller mesh types, light colours and in combination with daylight than with larger mesh types and darker colours. So let us advise you on the choice of system and configuration of the panels.

- Panel length (A) up to -6 mm
- Panel width (B) up to -4 mm
- Panel squareness (α) ±3 mm
- Edge heights (H) up to ±2 mm

MESH General information

B03

Edge / joint details

Most mesh products are offered in two design options, some either or.

Mesh

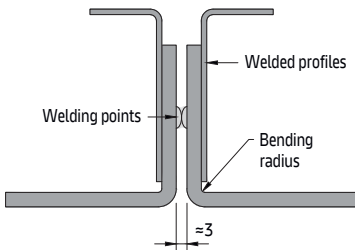

The mesh sheet edges are bent up 90° on all four sides. Reinforcement profiles are welded to the long edges and depending on the product, also to the short edges. The larger the mesh pattern, the bigger the bending radius and the potential tolerances.

Mesh MT

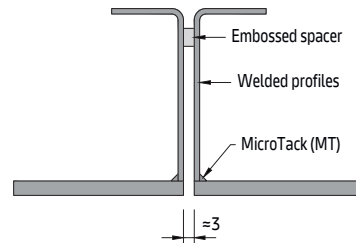

The mesh sheet remains flat. Reinforcement profiles are welded to the long and short sides by MicroTacks (MT). Depending on the mesh pattern, colour and incidence of light, these may be slightly visible from below.

The panels should be theoretically installed with a ≈ 3 mm open gap, which enables installation. Due to the tolerances, the gap size can be larger. During installation, the panels should always be laid in the predefined module size, even if the panel is smaller because of the tolerance. The joint is correspondingly larger.

Example: Module size of 400 mm

Theoretical panel width (B) = 397 mm = 3 mm gap

Delivered panel width (B) = 395 mm (-2 mm tolerance) = 5 mm gap

If these are pushed together to the theoretical joint dimension, an offset can occur at the crossing point and the ceiling looks restless as a result.

With the Mesh variant, the panels should therefore never be pushed together so that they touch. Due to the welding, the mesh ends can stand out a little. They would get wedged and make installation impossible.

Mesh MT panels are delivered with spacers, which guarantee the minimum distance between the elements. This is another reason why the panels can only be laid in one direction at a time.

The exception to this are the canopies, where the elements touch and have no spacers. These are delivered without spacers.

Handling

Correct handling of a Mesh MT panel

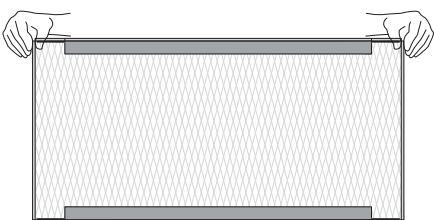

Large Mesh MT panel with welded stiffener

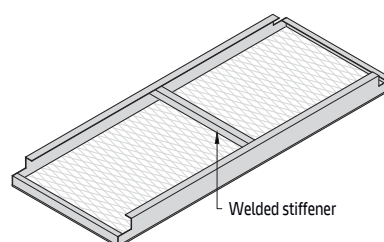

When a Mesh MT panel is removed from the packaging, it should always be pulled out by holding the ends and never by the middle of the long side, as this could break the MicroTacks. Longer panels therefore have an additional welded stiffeners, for additional stability.

MESH General information

B03

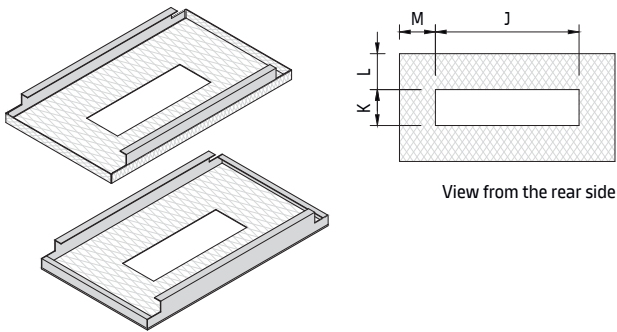
Cut-outs**Cut-out type 1**

Cut-outs for service integrations can be cut on site (see separate pages for cutting & modifications). If there are a large number of panels with the same cut-outs, these can be carried out at the factory.

There are two options to choose from, starting with round (type 4) or rectangular (type 1). The edge of the cut-out is always covered by the service integration.

In the case of prefabricated cut-outs, the position in the panel as well as the dimensions must be defined. The distances to the edges and dimensions of the cut-out depend on the selected system. Cut-outs and service integrations can affect panel stability and deflection.

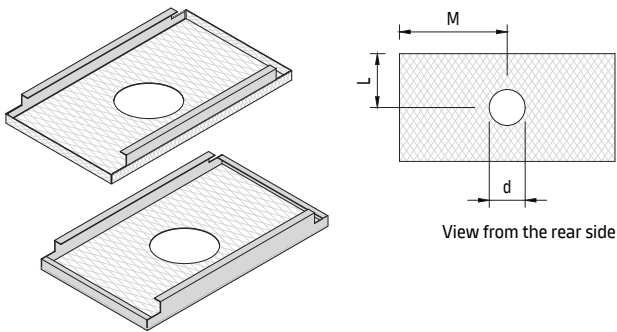
Cut-out type 4

On request, several cut-outs per panel can be made. When planning and ordering, the rectangular panel is shown as reclined and from the rear side.

Demountability

In general, all standard and configurable products can be removed individually. This ensures access to the cavity. After the panels have been reinserted, they and the neighbouring panels should be aligned again so that the joint pattern is correct.

For clip-in systems, extraction tools are required. Choosing the right tool is crucial and prevents damage to the product.

The direct access is not given when using security clips and brackets. The modules have to be dismantled from the last one that was not secured. The EASY hinge-down solution is available for some of the products to facilitate access.



MESH Board
Huracán Coffee, Vilnius, Lithuania © Szymon Polański



Suspension Systems

T-GRID (System C)

Exposed grid solution for indoor applications

General information

- Suitable for indoor use only
- All profiles meet durability class B, according to EN 13964
- All standard items are held in stock
- Various suspension options available, depending on market needs
- Tried and tested solution with extensive experience

Main Runners

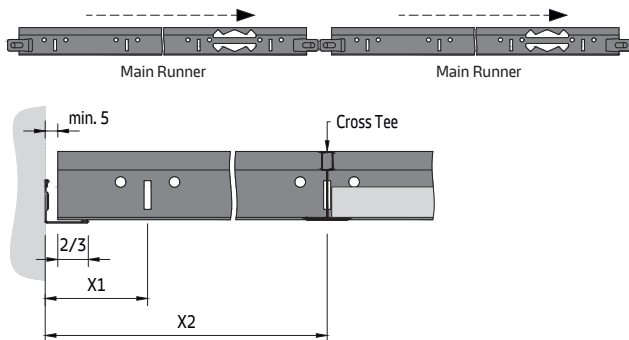

The Main Runners should always be installed in the same direction; two fire expansion notches should not be installed directly next to each other. Main Runner cuts result depending on the ceiling symmetry as well as the cut tile width. The profiles should be cut to length so that the punching and therefore the layout of the Cross Tees is aligned. For every new row, the dimension X1 or X2 should be checked. To ensure system alignment (squareness) and stability, all profile cuts should leave a 5-10 mm perimeter gap. In addition, the profile should sit on the trim to at least 2/3 of the trim flange width.

Main Runner / Cross Tee connection

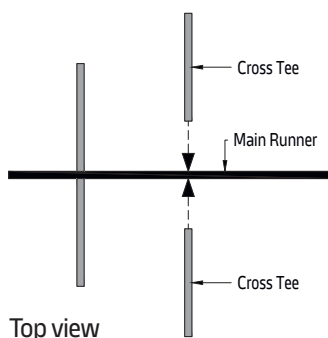

The handling of the Cross Tee connectors will differ during assembly, depending on the selected grid system (plug / click with audible engagement; left / right aligned), but also during disassembly.

Important information

The appropriate grid system and layout must be determined based upon the tile weight and additional loads. The corresponding load information and available components can be found in the respective data sheets. Components (Main Runners and Cross Tees) from different systems cannot be mixed.

Tile installation direction

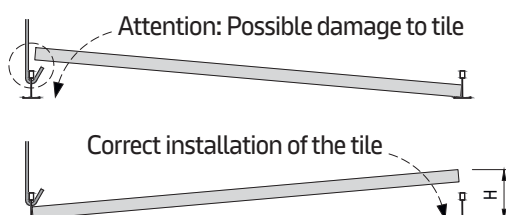

Particularly when using wire hooks, there is risk of damaging the tiles during installation. Please note the installation diagram opposite. Demounting should be carried out accordingly (lifting the tiles on the side with no hanger). In principle, assembly and disassembly should not be carried out starting from Main Runners, as there is always a risk of collision with a hanger and damage to the tile edges. The minimum height (H) to be able to insert and remove the tiles depends on the chosen system and is covered in the specific chapter.

T-Grid (System C)

C01

Square tiles

Layout 1

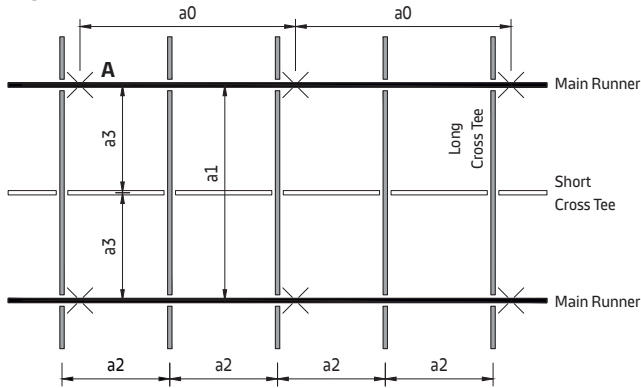

Between the Main Runners centres (a_1), a long Cross Tee is fitted at (a_2) centres. These Cross Tees are then subdivided by short Cross Tees at (a_3) to form the square module layout. The distance (a_0) stands for the distance between the suspension points.

Layout 2 - not permitted

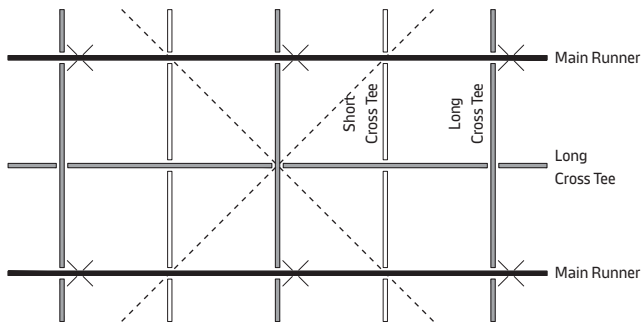

This construction is **not** permitted. A combination of long Cross Tee and second long Cross Tee parallel to the Main Runners due to increased deflection of the system.

Layout 3

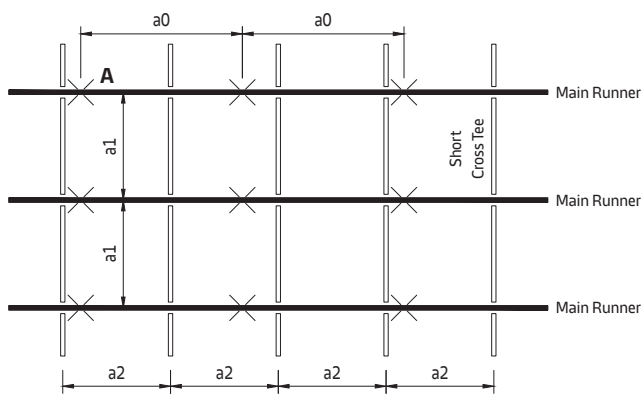

Due to the small Main Runner centres (a_1) and the use of short Cross Tees at (a_2) centres, this construction can support heavier loads. Long Cross Tees are omitted and therefore the material requirements of Main Runners and short Cross Tees is increased.

T-grid

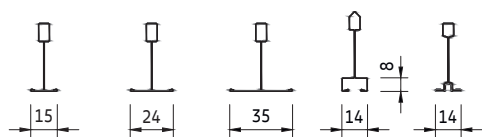

These are typical examples of T-grid. Detailed information and available options can be found in the product datasheets.

T-Grid (System C) C01

Parameters

- a0 Max. distance between Main Runner suspension points
- a1 Distance between Main Runners
- a2 Distance between long Cross Tees (module width)
- a3 Distance between Main Runner and short Cross Tees (module length)
- a4 Distance from wall to first suspension point = max. 250 mm

Values see specific data sheets of the products.

Rectangular tiles

Layout 1

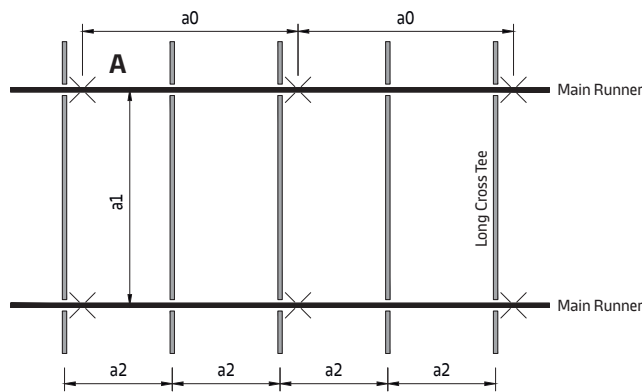

If the tiles are rectangular then the short Cross Tees are not required. Between the Main Runners centres (a_1), a long Cross Tee is fitted at (a_2) centres.

Layout 2 - not permitted

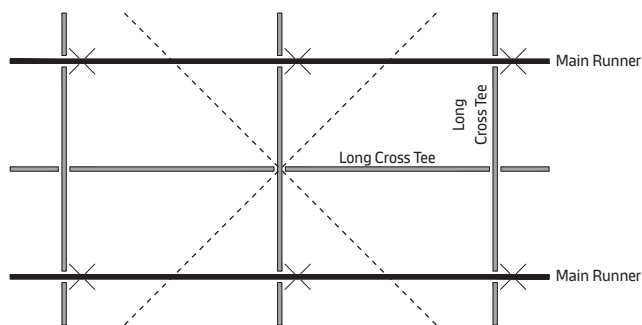

This construction is **not** permitted. A combination of long Cross Tee and second long Cross Tee parallel to the Main Runners due to increased deflection of the system.

Layout 3

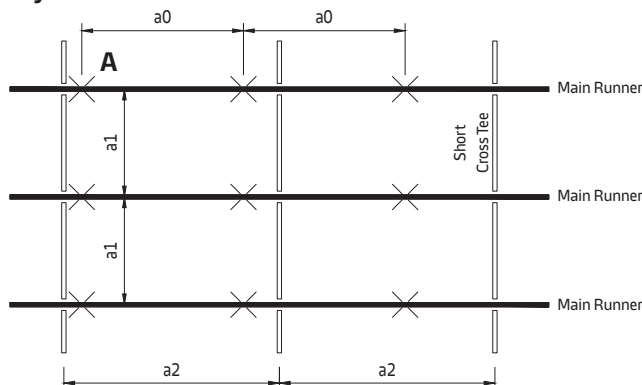

Due to the small Main Runner centres (a_1) and the use of short Cross Tees at (a_2) centres, this construction can support heavier loads.

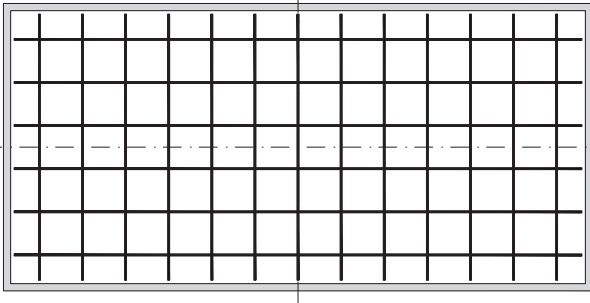
Installation guidelines**Layout 1**

After determining the ceiling symmetry / layout, the direction of the Main Runners is determined. The long side of the room is normally chosen, but sometimes due to fixtures and fittings etc., the short direction may be more favourable.

Perimeter trims

As preparation before the installation, all perimeter features (walls, columns etc.) should be marked with the ceiling height (the height of the top edge of the perimeter trim). Perimeter trims should be fixed as per chapter Perimeter trims (approved fixings, centres etc.)

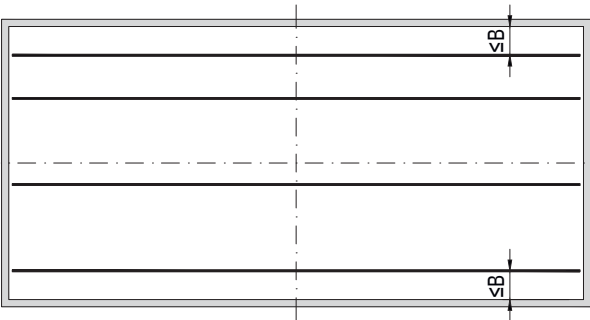
Layout 2

The fixing points of the hangers are determined by the layout of the Main Runners. The distance of the first and last Main Runner from the wall should be smaller than module width B, so that laying long Cross Tees on the perimeter trim is avoided.

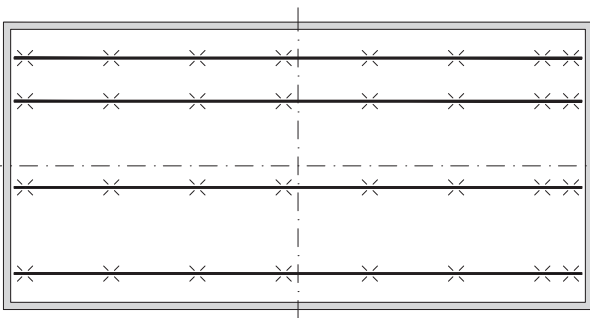
Layout 3

The fixing points are marked on the soffit using a chalk line, for example.

In addition to the relevant system hanger centres (load capacity of the grid system), additional hangers may be required for:

- Main runner joints / fire expansion notches
- Maximum perimeter distances (first and last hangers)
- Fixtures and fittings

It is recommended that the hangers are adjusted to the required length before installation, later only the fine adjustment is required.

Soffit fixings is carried out with approved fixings as per the screw /plug manufacturer's recommendations. All hangers are to be installed in the same direction (e.g. direction of butterflies or hooks etc.) and vertical.

T-Grid (System C)
C01

Layout 4

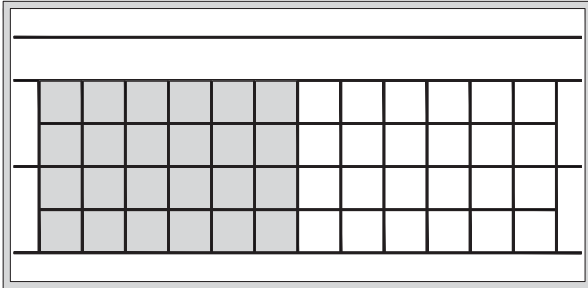

To complete the system, long and short Cross Tees are installed as required. To align and square the system, it is recommended to insert a few tiles and where necessary adjust the system before the entire grid system installation is complete.

Squareness check

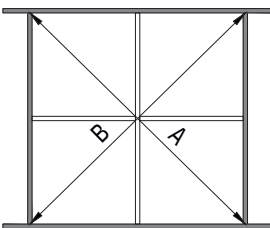

Diagonal A = Diagonal B

Please ensure that the system and the profiles are installed at right angles to each other or correct this where necessary. This should be done as early as possible in the installation to reduce realignment work to a minimum.

Failure to do so can lead to major problems when installing the tiles, especially with recessed edge designs, e.g. edges at...

MINERAL: Tegular 15, Tegular 24, Tegular 15/90 ...

HERADESIGN: SK-05, SK-06 ...

METAL / MESH / WOOD: Microlook, Tegular... and semi-exposed systems e.g. Vector edge

Furthermore, there is an increased risk of damage to tiles during subsequent demounting or maintenance.

Layout 5

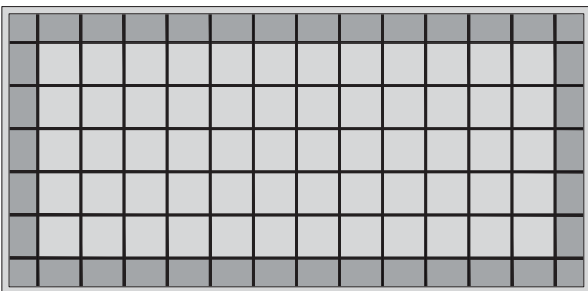

Finally, all profile and tile cuts are completed. The minimum support on perimeter trims should be adhered to.

Suspension heights

The following suspension heights enable simple installation of the tiles from below.

For low suspension heights, e.g. direct hangers, the profiles and tiles must be installed alternately.

T-Grid (System C)

C01

Hangers

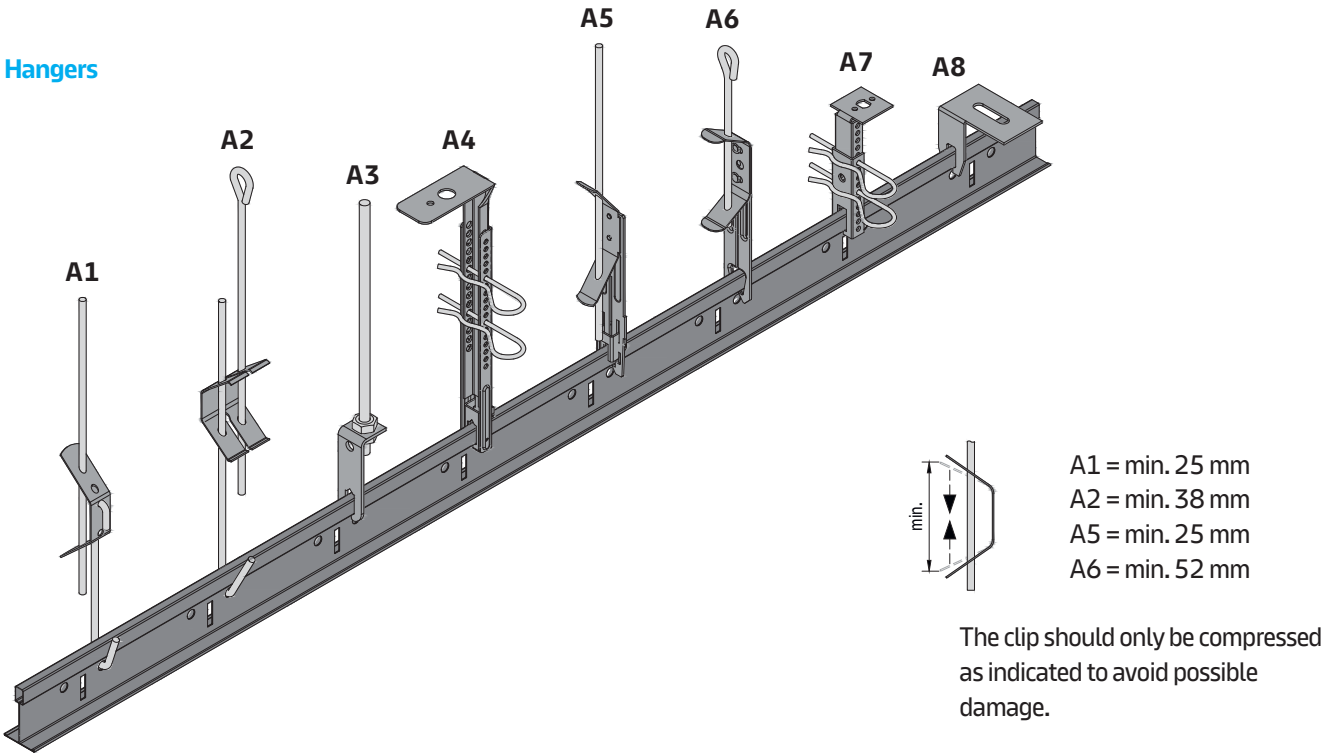

There is a range of suspension hangers available for the System C grid. Depending on the suspension height, object-related circumstances, availability or preference, all types can be used. It is important to ensure however, that the maximum load bearing capacity is not exceeded and the choice fits the system and the requirements.

In the case of push-on hangers, care is needed to ensure that installation and removal of the tiles does not displace the hangers. When using push-on hangers, the direction of installation should be at 90° to the Main Runners, tension free and vertical.

Hangers with visible defects must not be used.

Improper handling, such as forcibly bending open and closed tabs / parts of the hanger, will result in a loss of load-bearing capacity.

Hanger type		Min. installation height (H) [mm]
A1	Butterfly hanger with hook	140
A2	Quick hanger with loop	100
A3	Bent tee bar hanger for threaded rod	100
A4	Nonius top and bottom part	200
A5	Hanger Clickfix II	130
A6	SAH10 plus	130
A7	Direct hanger	80
A8	Direct hanger	65

Not all combinations of grid systems / Main Runner and hanger are possible. This primarily applies to hangers for sliding on and clipping on due to the different profile head heights and shapes - rectangle / roof (peak).

T-Grid (System C) C01

Hanger installation

A2

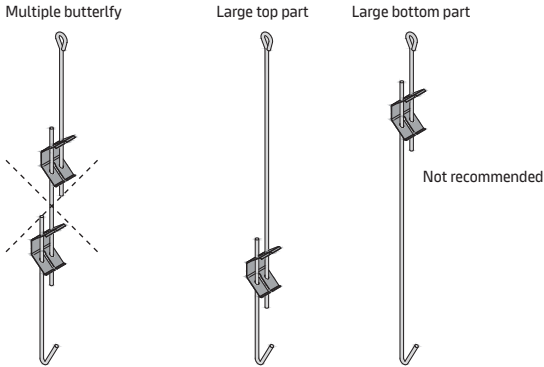

To facilitate access to the butterfly, it is recommended to use a longer eye wire (top part).

A4

Nonius hanger extension

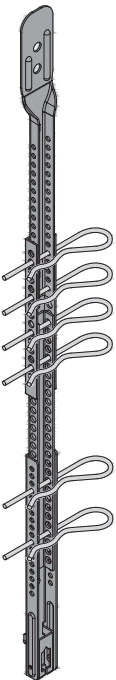

Hangers must be installed vertically. The maximum hanger distance depends on the selected product (see specific product datasheets). In addition, a hanger is required at each Main Runner join and additional loads for service integrations require a minimum of two hangers (see Cutting & Modifications document). It should be ensured, that the distance from the perimeter to the first and last hanger does not exceed the maximum dimension (see specific product pages) and additional hangers should be installed where required.

Angled hangers can significantly reduce the load bearing capacity and not all hangers are suitable for. In most cases, additional measures (cross bracing, additional hangers etc.) are required.

For suspension heights of up to 3000 mm, suitable suspension wires can be obtained as standard for different variants. For suspension heights over 3000 mm Nonius hangers (A4) are recommended.

A combination of multiple butterflies (A2) or extensions is not permitted. Greater suspension heights can be created using suitable special lengths (the longest possible upper section facilitates accessibility and subsequent adjustment). A combination of different hangers / parts is not permitted.

Hangers subject to compression

In normal situations the hangers are subjected to tension (ceiling tiles, grid structure, service integrations, etc.). Certain applications may subject the hangers to compression forces. These applications can only be carried out with Nonius hangers. It is only limited available and must be clarified in relation to the object. Please make sure that the elements have an overlap of at least 40 mm.

Fire rated applications

For fire rated applications, the relevant test certificates apply. Separate documents are available.

Perimeter hangers

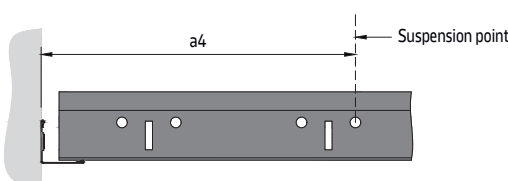

To avoid overloading the perimeter trim, the first hanger must be positioned at a maximum distance from the perimeter (a4). Depending on the system selected, the grid does not necessarily have to rest on the perimeter trim.



U-PROFILE PRIMARY GRID

Primary grid solution for indoor applications

General information

- Modular primary grid concept for small, medium, large rooms and floating solutions, with a minimum number of components
- For perpendicular installation with secondary grid
- High longitudinal and transverse stability
- Simple and time-saving installation, due to the use of system components
- All standard items are held in stock
- Various suspension options available, depending on market needs
- Tried and tested solution with extensive experience

Isometric view

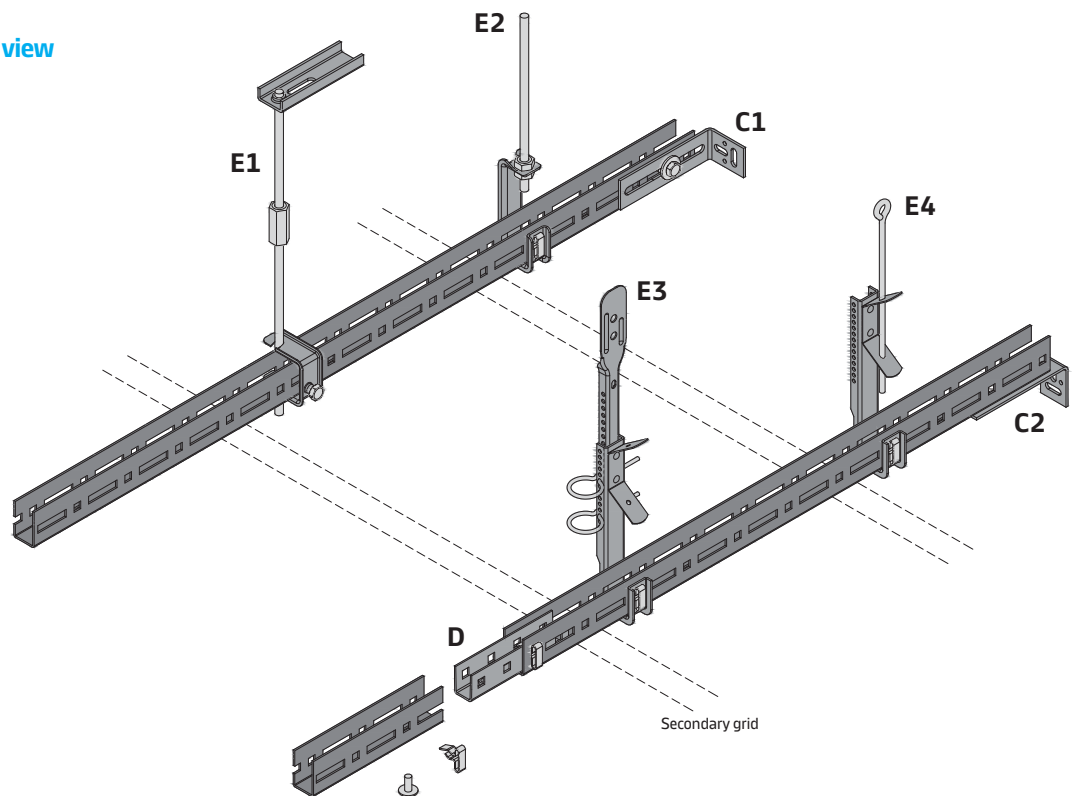

Important information

The U-Profile system fulfils the two conditions required in the European standard (EN 13964) concerning load-bearing capacity (2.5 times the failure criterion) and performance capability (deflection restriction).

Section A

Example with suspension option E1

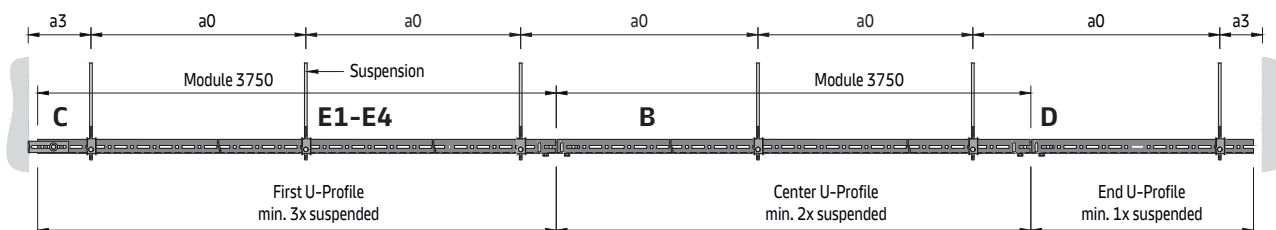

U-Profile Primary Grid C02

Primary grid components

Standard components

- M300100 U-Profile
- M300119 Splice connector for U-Profile
- M300140 Wall anchor
- M300120 Plug-in clip for U-Profile
- M311103 Hexagonal nut M6
- M311105 Washer
- M311303 Hexagonal bolt M6 x 16 mm

Suspension options E1 - E4 components

Suspension option D1

- M300121 Clamping bracket for U-Profile
- M311101 Threaded rod M6 x 1000 mm
- M311315 Hexagonal extension nut M6 x 30 mm (optional)
- M311061 Suspension element (optional)

Suspension option D2

- M300366 Hanger for U-Profile
- M311103 Hexagonal nut M6
- M300120 Plug-in clip for U-Profile
- M311315 Hexagonal extension nut M6 x 30 mm (optional)
- M311061 Suspension element (optional)

Suspension option D3

- M300166 Combi-Nonius hanger for U-Profile
- - Nonius top part (various lengths)
- M300036 Nonius locking pin
- M300120 Plug-in clip for U-Profile

Suspension option D4

- M300166 Combi-Nonius hanger for U-Profile
- - Eye wire (various lengths)
- M300120 Plug-in clip for U-Profile

Detail B

U-Profile modulation

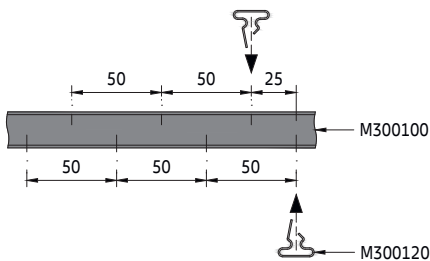

The U-Profile primary grid is a modular system based on a spacing of 50 mm. The holes on the lateral sides are offset from each other by 25 mm. This means that distances of 25 mm can be achieved. Other sizes covered by the long holes.

Example B1

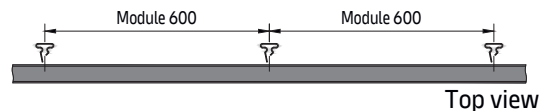

With a module size of e.g. 600 mm, the plug-in clips are always attached to the same side.

Example B2

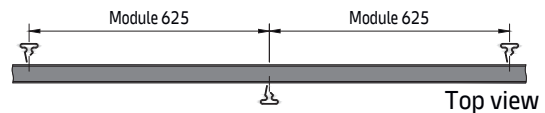

With a module size of e.g. 625 mm, the plug-in clips are attached alternately.

U-Profile

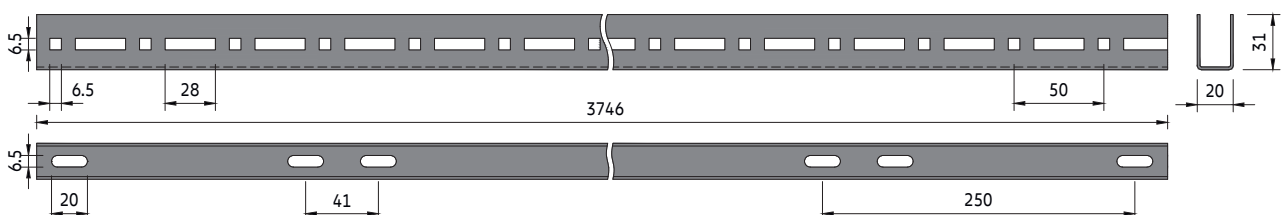

U-Profile Primary Grid C02

Typical grid layout

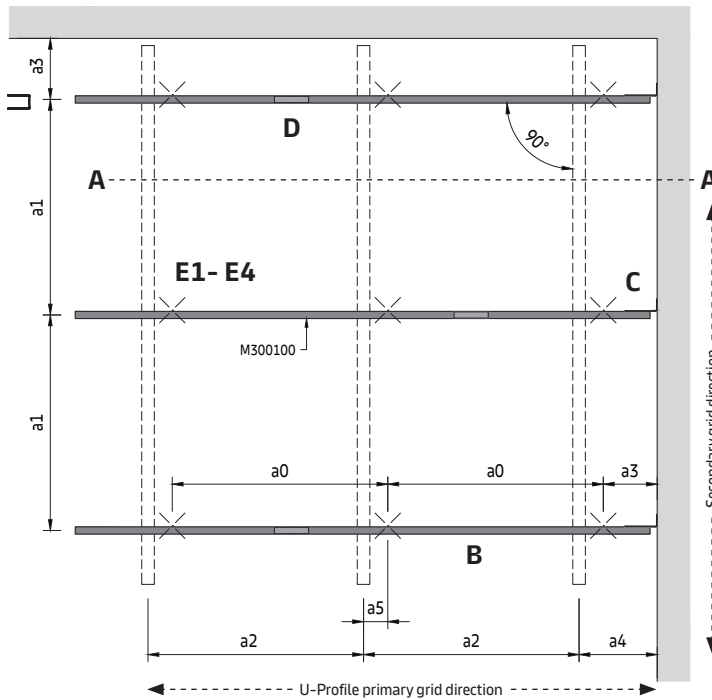

Parameters

- a0 Distance between U-Profile suspension points = max. 1900 mm
- a1 Max. distance between U-Profiles
- a2 Distance between secondary grid
- a3 Distance from wall = max. 200 mm
- a4 Distance from wall = max. panel length
- a5 Distance from U-Profile suspension point to hanger = max. 100mm

The required distances are shown in combination with the secondary grid and will vary depending on the system chosen.

U-Profile alignment

The U-profiles should be installed vertically and on the same level, in a max. distance of (a1).

Installed incorrectly



Installed correctly

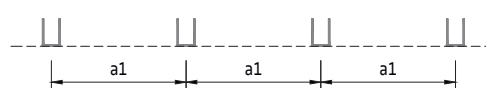

U-Profiles should be aligned with each other in the longitudinal direction, otherwise the module will not be aligned.

Installed incorrectly

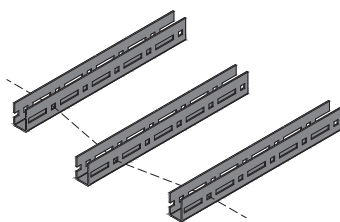

Installed correctly

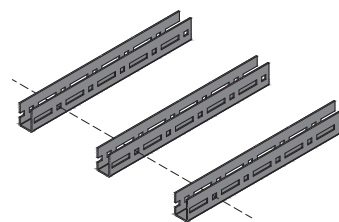

U-Profile Primary Grid

C02

Detail C

Wall fixing

The wall anchor can be attached either to the side (option C1) or below the U-Profile (option C2). It prevents the U-Profile from swinging and thus contributes to the safe installation of the substructure. The wall anchor has no load-bearing function and is only attached to one end of the room to secure the U-Profile. Maintain a small gap between the U-Profile and the wall.

Option C1

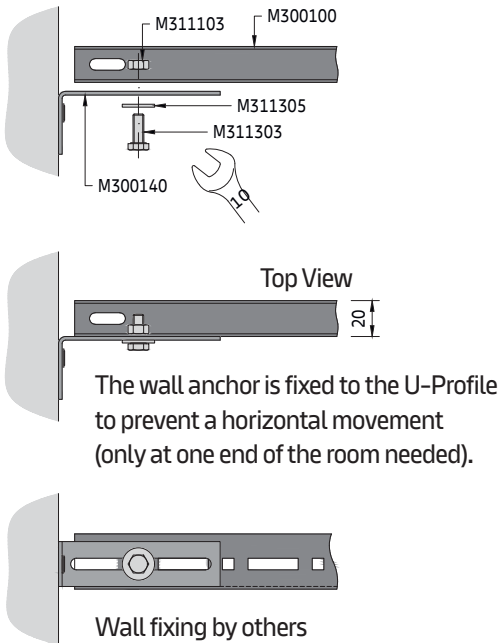

Option C2

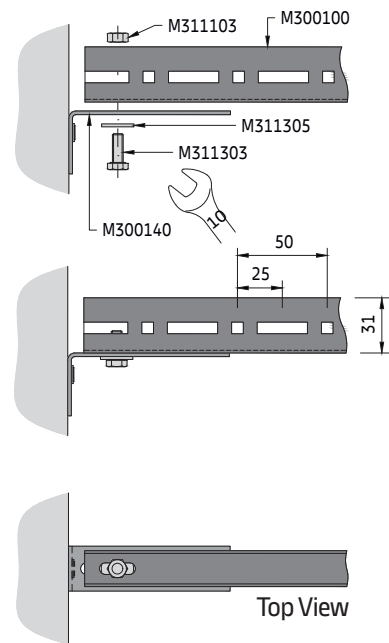

Detail D

Splice connection

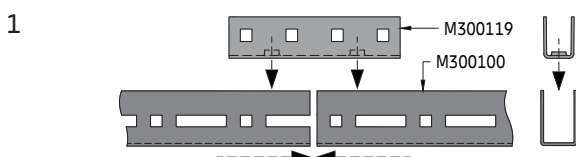

The splice connector for U-Profile comes with two bolts, which must first be removed. The splice connector is then placed between the two ends of the U-Profiles.

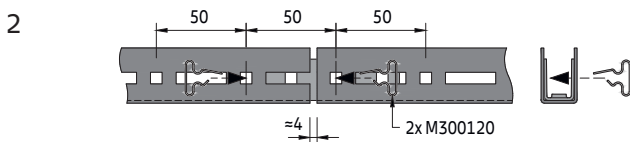

Fix the splice connector with two plug-in clips (large end upwards) at each end. This maintains the modular distance of 50 mm.

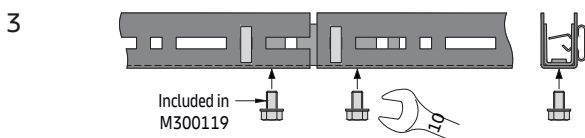

For a stable connection, the two supplied bolts are attached from below.

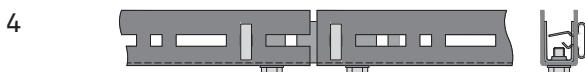

Since the U-Profile is a modular system, the ends must not touch. There is a distance of approx. 4 mm, depending on the length tolerance of the profile. Joints should be offset across the ceiling area.

Detail J

Suspension options

Option E1

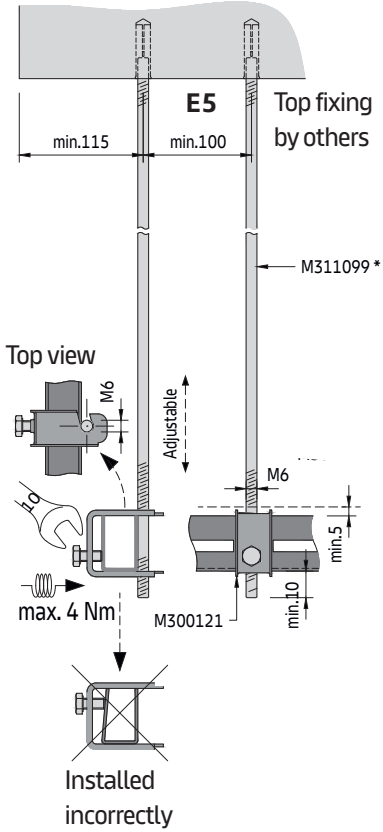

Option E2

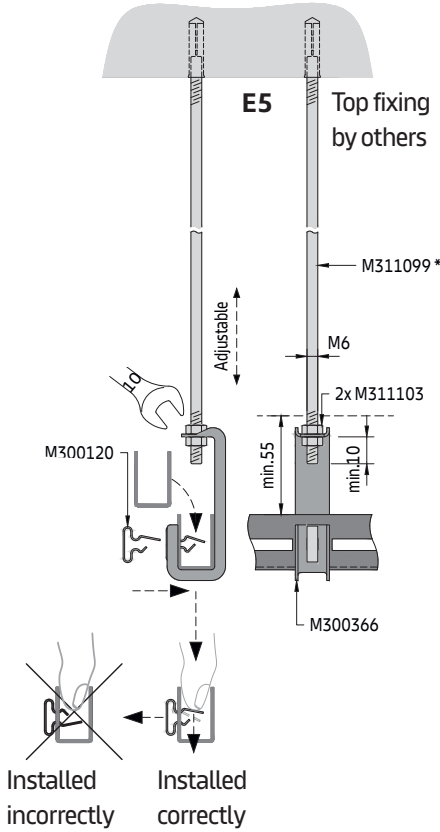

Option E3

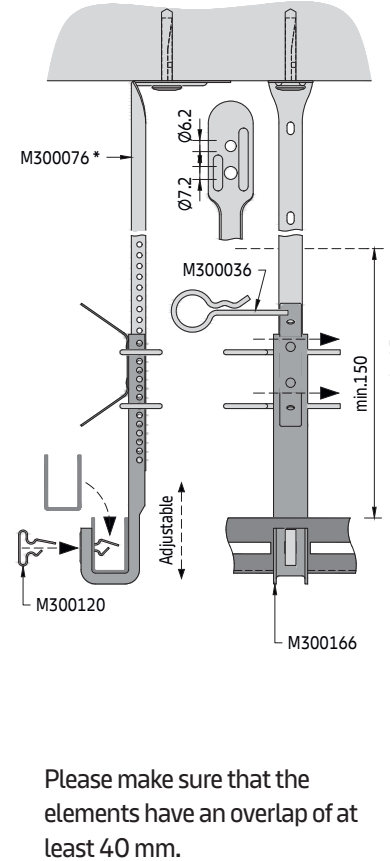

Option E4

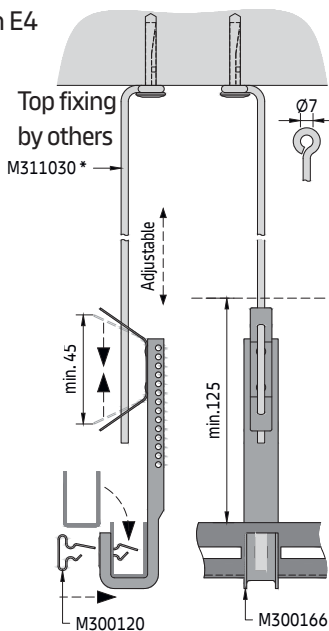

The suspension point should always be chosen close to the crossing point of the primary and secondary grid (a5) in order to absorb the ceiling load as best as possible and to prevent the U-profile from potentially deflecting.

Minimum pull-out force per suspension point = 1.25 kN (failure state)

Maximum permissible load per suspension point = 0.50 kN (incl. 2.5 times safety). These values must always be observed and guaranteed by the installation company for each suspension point irrespective of the type of hanger selected.

Detail E5

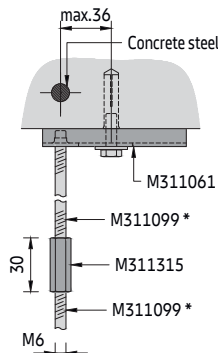

Optional top fixing and extension detail for suspension option E1 / E2

The clip should only be compressed as indicated to avoid possible damage.

* Various lengths available

U-Profile Primary Grid

C02

General installation sequence

- 1 The position of the suspension points must be marked on the soffit before installation (laser, measuring tape, chalk line, etc.). Then drill the holes and place the top fixing (not offered by Knauf Ceiling Solutions).
- 2 Set threaded rods, Nonius top parts or eye wires, shorten if necessary.
- 3 Wherever possible, fixing should begin on the centre axis of the ceiling area.
- 4 Align the wall angle with the laser (lower edge of the visible side of the ceiling components) and attach to the perimeter walls.
- 5 Suspension options:
 - E1** - Fasten the U-Profile to the threaded rod using a clamping bracket and align the height.
 - E2** - Align the height of the U-Profile hanger and fasten it to the threaded rod with two hexagonal nuts, then hang in the U-profile and fix the position with plug-in clips.
 - E3** - Align the height of the combi-Nonius hanger and fasten it to the Nonius top-part with two safety clips, then hang in the U-profile and fix the position with plug-in clips.
 - E4** - Align the height of the combi-Nonius hanger and fasten it to the eye wire, then hang in the U-profile and fix the position with plug-in clips.The minimum installation height is depending on the selected suspension option **E1 - E4**.
- 6 U-Profiles should be aligned with each other in the longitudinal direction and joints should be offset. Couple the U-Profiles with splice connectors and fix them to the perimeter walls with the wall anchor at one end of each row of U-Profiles.
- 7 See secondary grid pages for further steps.
- 8 Lay full ceiling elements, followed by cut or full perimeter elements.
- 9 Service integrations and additional loads must be suspended separately from the soffit. The additional measures must be carried out professionally.

U-Profile Primary Grid C02

U-Profile bridging carrier

The U-Profile bridging carrier option has been designed as a single or continuous solution for smaller areas where direct suspension from the soffit is not possible with standard spacing. It is based on the standard U-Profile installation. The bridging carrier can either be added to the standard primary grid structure or installed on top of it as an additional layer. Use on large areas is not recommended as assembly is time consuming, but still quicker than leaving the job site for another solution. The connector and bolts can be stored in the tool box. This means that you always have a quick and easy solution to hand when you need it. When planning, it is important to ensure that the connectors are positioned so that they do not interfere with the suspension point (**E1**) nor the hanger for the secondary grid. The distance between the connectors (a_9) and to the suspension point (a_{10}) must not be exceeded.

Isometric view

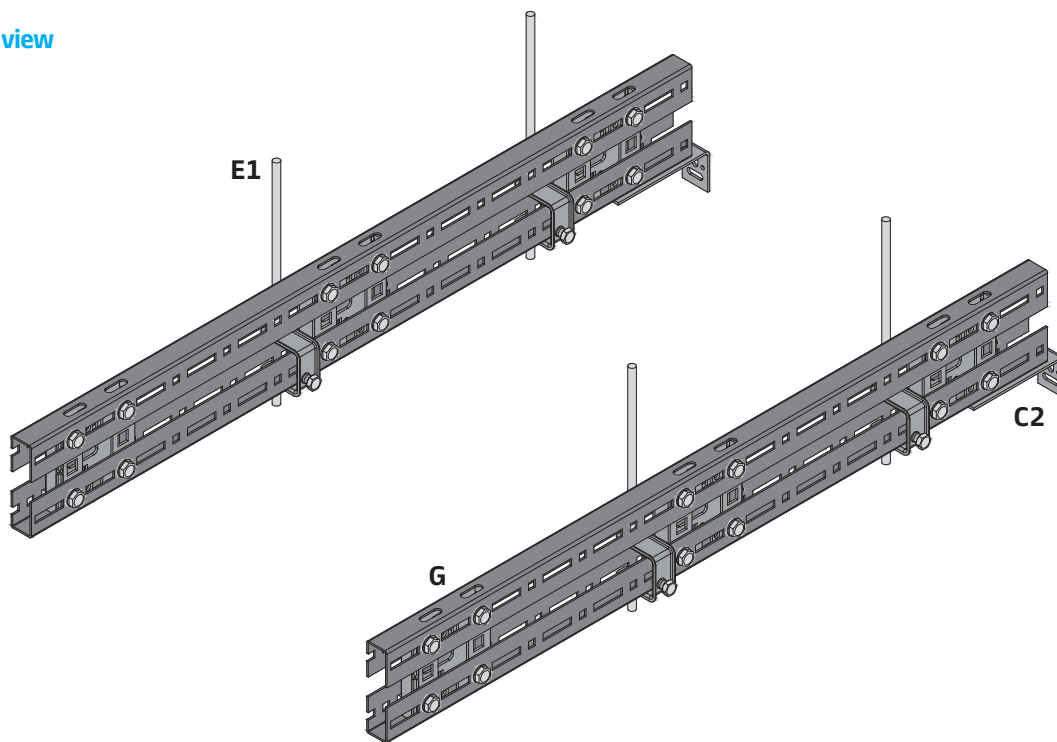

Single bridging carrier

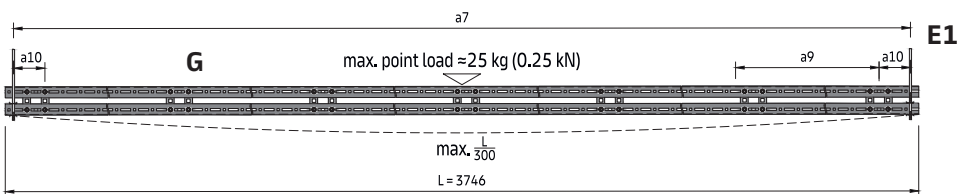

Continuous bridging carrier

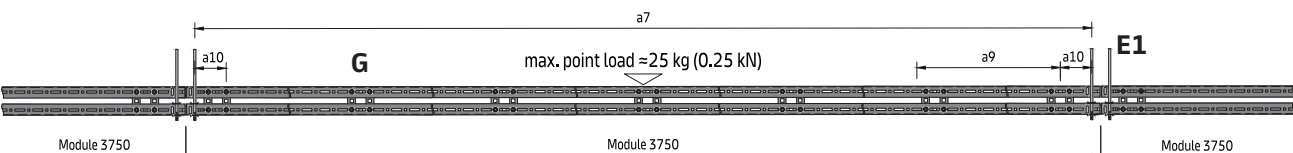

U-Profile Primary Grid

C02

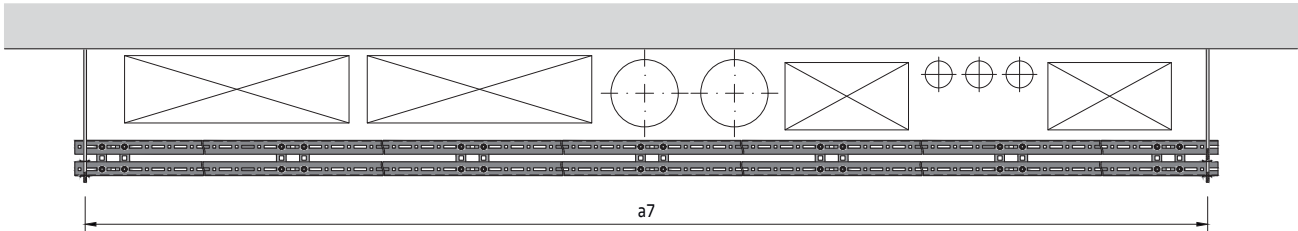
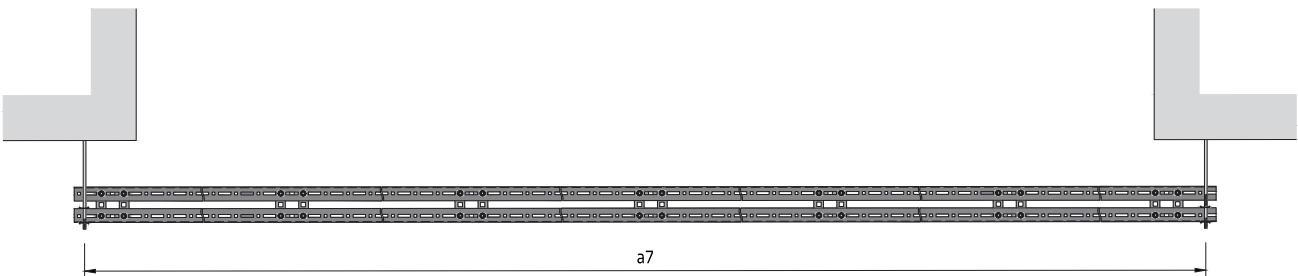
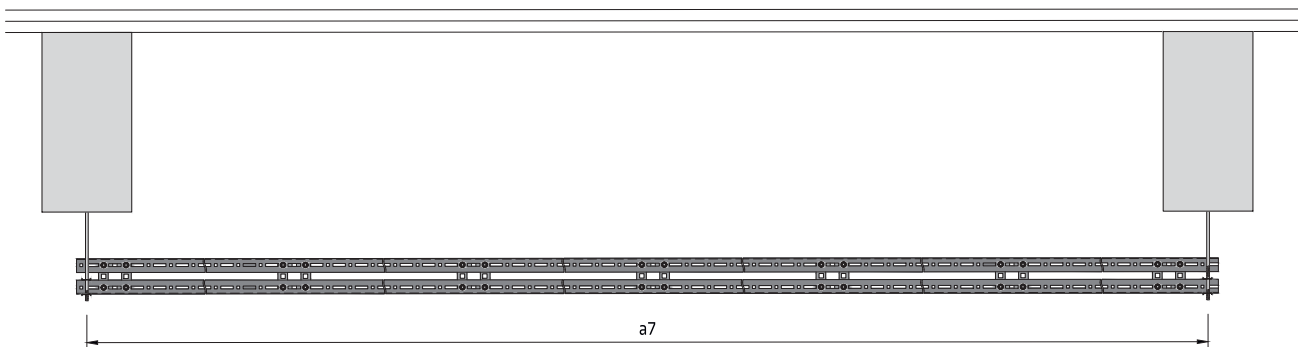
Application area 1**No fixation possible, due to building equipment****Application area 2****No fixation possible, due to ceiling aperture****Application area 3****No fixation possible, except on beams****U-Profile bridging carrier components****Standard components**

- M300101 Connector for U-Profile bridging carrier
- M311195 Thread cutting bolt M6 x 10 mm

U-Profile Primary Grid

C02

Spacing for DP12 A-Bar / L-Profile

a7 [mm]	System without additional load		System with additional load +4 kg/m ²	
	a8 [mm]	a8 [mm]	a8 [mm]	a8 [mm]
2800	1900		1900	
2900	1900		1900	
3000	1900		1800	
3100	1900		1650	
3200	1900		1500	
3300	1900		1350	
3400	1900		1250	
3500	1750		1150	
3600	1600		1050	
3700	1500		950	

Spacing for Spring-T / J-Bar

a7 [mm]	System without additional load		System with additional load +4 kg/m ²	
	a8 [mm]	a8 [mm]	a8 [mm]	a8 [mm]
2800	1900		1900	
2900	1900		1900	
3000	1900		1750	
3100	1900		1550	
3200	1900		1400	
3300	1900		1300	
3400	1800		1200	
3500	1650		1100	
3600	1500		1000	
3700	1400		900	

Spacing for H-Profile 28 / H-Profile 35

a7 [mm]	System without additional load		System with additional load +4 kg/m ²	
	a8 [mm]	a8 [mm]	a8 [mm]	a8 [mm]
2800	1900		1900	
2900	1900		1900	
3000	1900		1800	
3100	1900		1700	
3200	1900		1550	
3300	1900		1400	
3400	1900		1250	
3500	1850		1150	
3600	1700		1050	
3700	1550		1000	

Spacing for C-Profile / Bandraester

a7 [mm]	System without additional load		System with additional load +4 kg/m ²	
	a8 [mm]	a8 [mm]	a8 [mm]	a8 [mm]
2800	1900		1900	
2900	1900		1750	
3000	1900		1550	
3100	1900		1400	
3200	1850		1300	
3300	1700		1150	
3400	1550		1050	
3500	1400		1000	
3600	1300		900	
3700	1200		850	

U-Profile Primary Grid

C02

Typical grid layout

Bridging carrier as part of the U-Profile primary grid

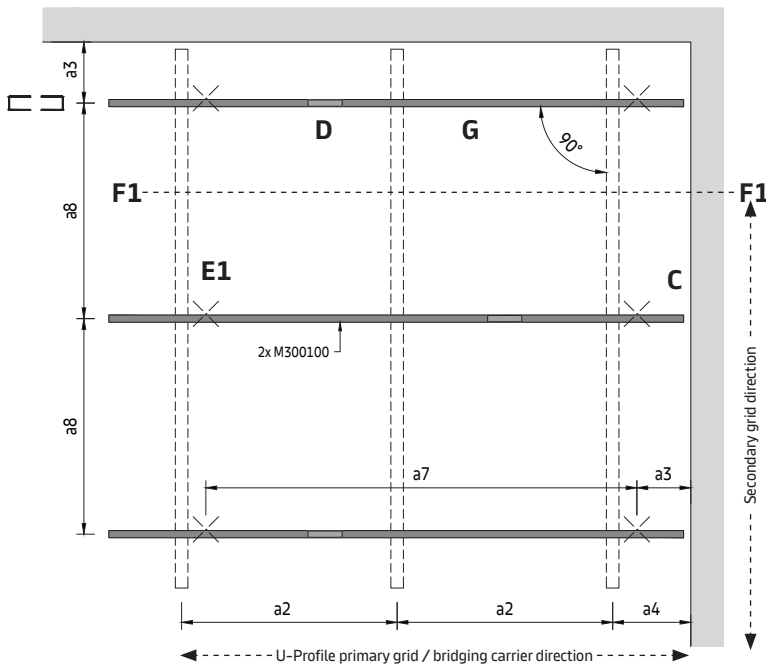

Bridging carrier as additional layer above the U-Profile primary grid

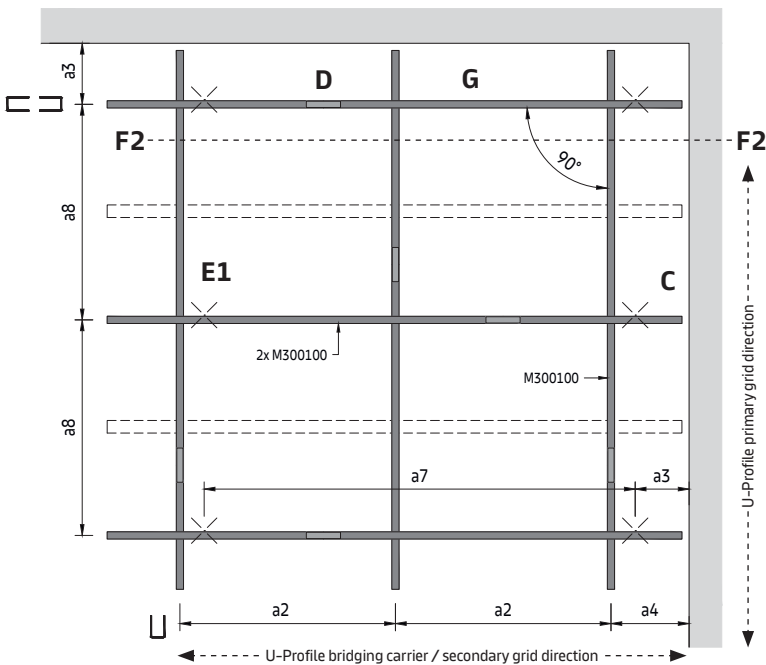

Parameters

- a7 Distance between U-Profile bridging carrier suspension points = max. 3700 mm
- a8 Max. distance between U-Profiles bridging carriers
- a9 Distance between U-Profile bridging carrier connectors = max. 600 mm
- a10 Distance between U-Profile suspension point and connector = max. 100 mm

U-Profile Primary Grid

C02

Section F1

Bridging carrier as part of the U-Profile primary grid

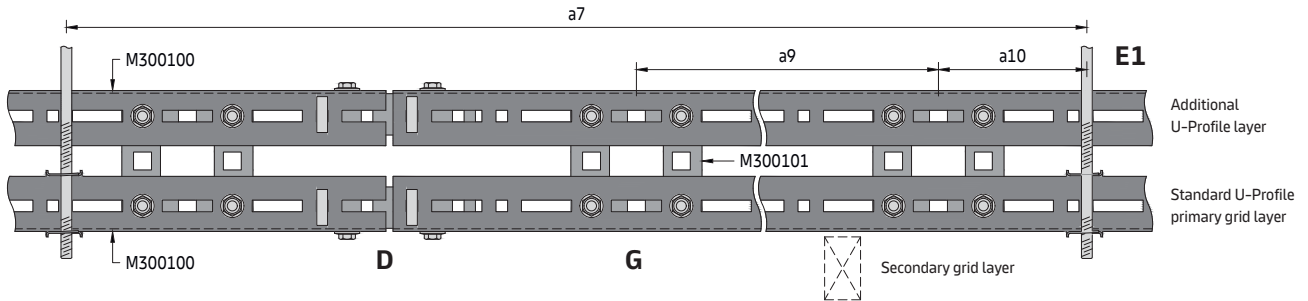

With this option, the U-Profile is reinforced with a second one above it. The secondary grid below is installed as in the standard installation.

Section F2

Bridging carrier as additional layer above the U-Profile primary grid

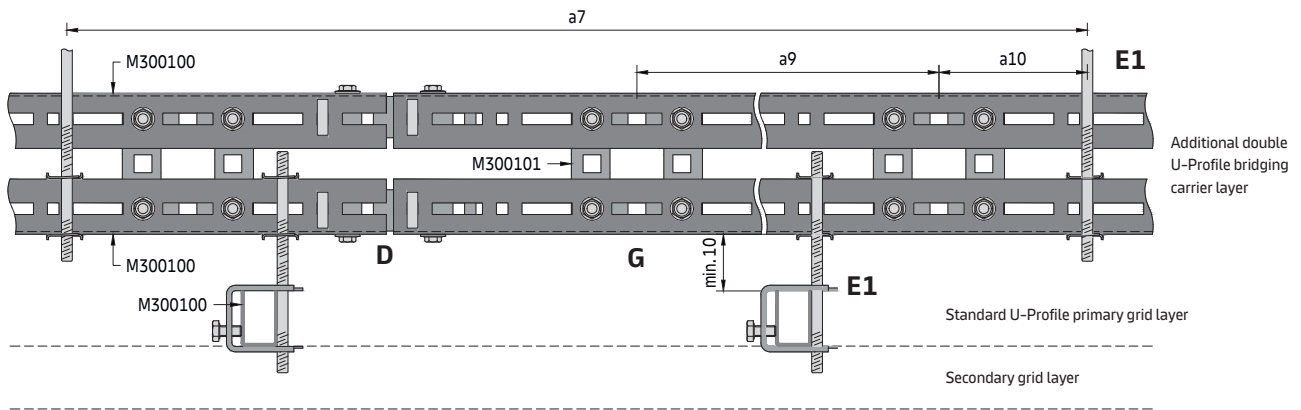

With this option, the U-Profile primary grid and the secondary grid are installed as in the standard installation. Additionally, a U-Profile bridging carrier layer is added above.

Detail G Connector

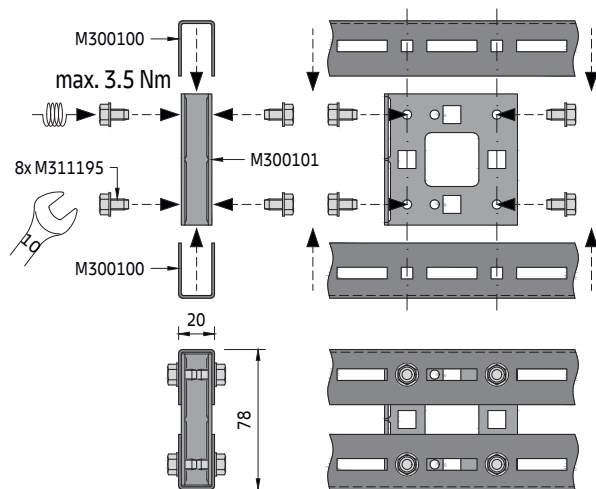
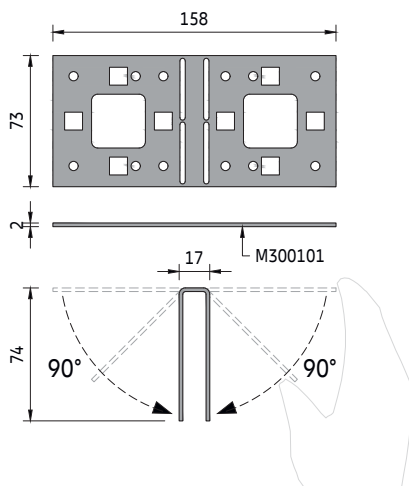

The connector is supplied as a flat piece, which saves space, and is hand bent into a U-shape before installation.

Place the connector between the two U-Profile layers and connect it with the thread cutting bolts. In order to create a stable connection, 8 bolts are required per connector.



PRIMARY ANGLE PRIMARY GRID

Primary grid solution for indoor applications

General information

- Primary grid concept for small, medium and large rooms, with a minimum number of components
- Two options of primary angle available
- For installation with secondary grid
- All standard items are held in stock
- Tried and tested solution with extensive experience

Isometric view

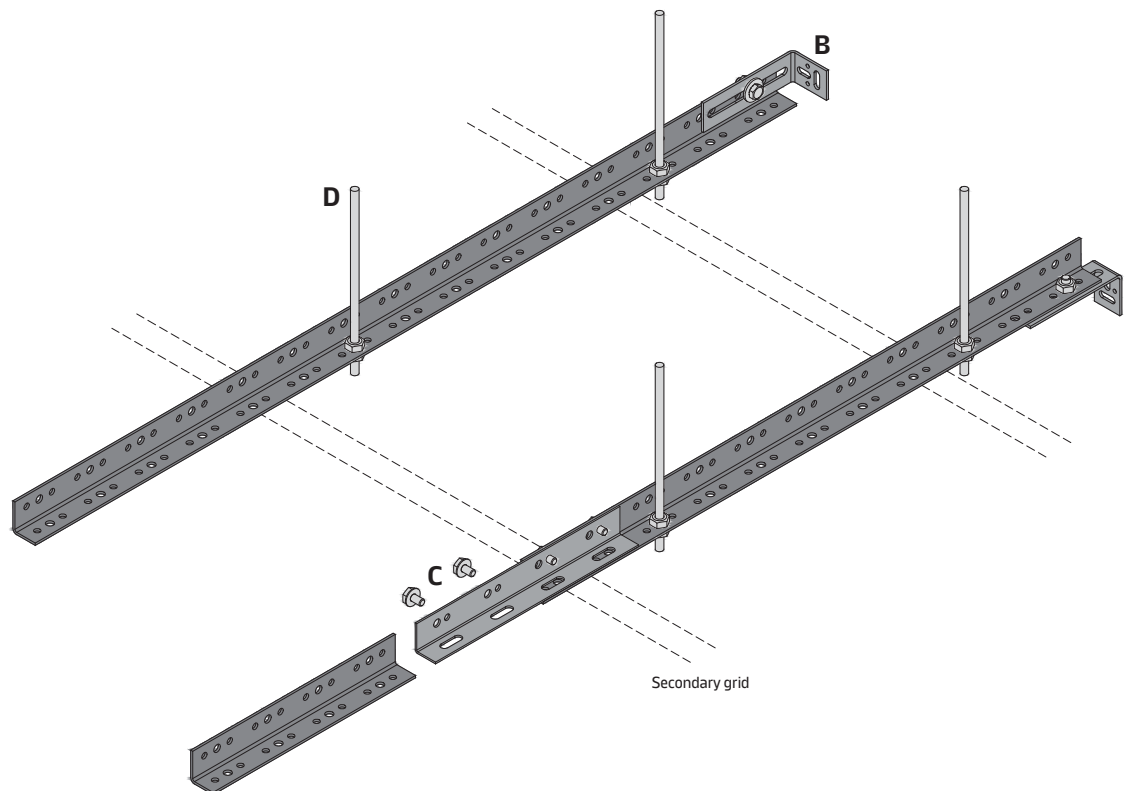

Important information

The primary angle system fulfils the two conditions required in the European standard (EN 13964) concerning load-bearing capacity (2.5 times the failure criterion) and performance capability (deflection restriction).

Section A

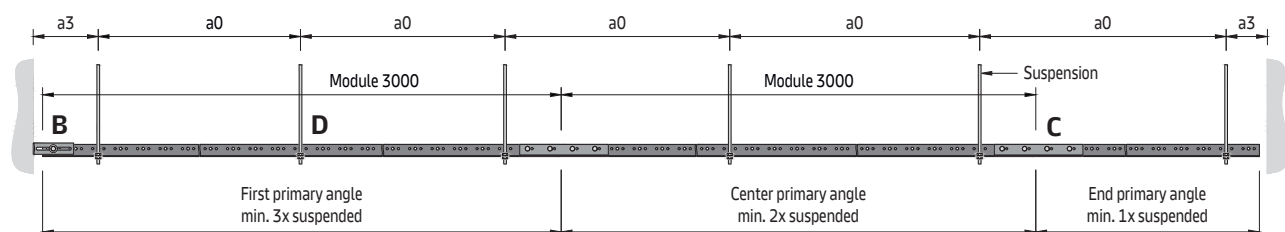

Primary Angle Primary Grid

C04

Typical grid layout

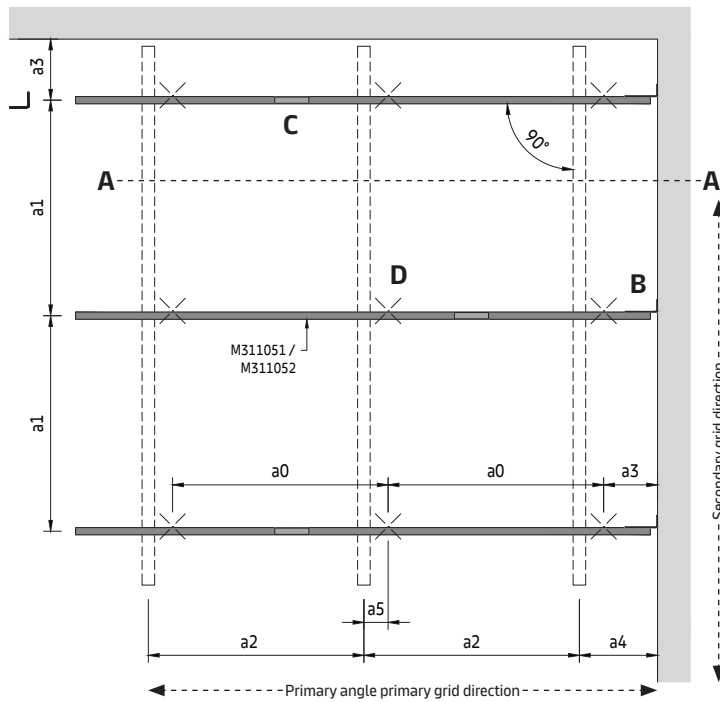

Parameters

- a0 Distance between primary angle suspension points = max. 1900 mm
- a1 Max. distance between primary angles
- a2 Distance between secondary grid
- a3 Distance from wall = max. 200 mm
- a4 Distance from wall = max. panel length
- a5 Distance from primary angle suspension point to hanger = max. 100 mm

The required distances are shown in combination with the secondary grating and will vary depending on the system chosen.

Primary angle 27 x 22 mm

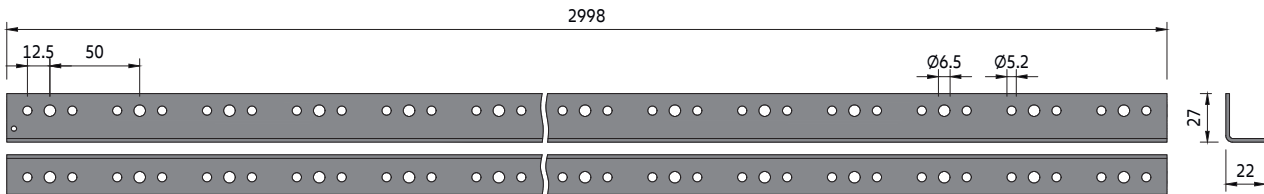

Primary angle 50 x 22 mm

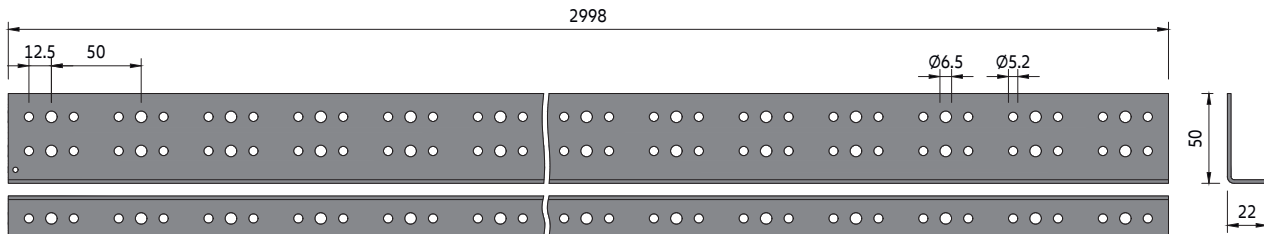

Primary Angle Primary Grid C04

Primary angle alignment

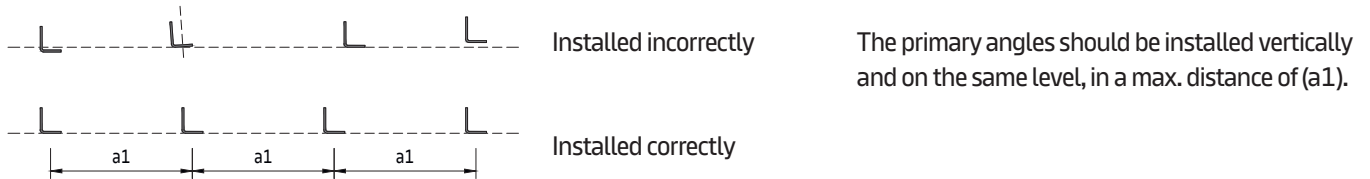

Detail B

Wall fixing

The wall anchor can be attached in two different ways to the primary angle (option B1 / B2). It prevents the primary angle from swinging and thus contributes to the safe installation of the substructure.

The wall anchor has no load-bearing function and is only attached to one end of the room to secure the primary angle. Keep some distance from the primary angle to the wall.

Option B1

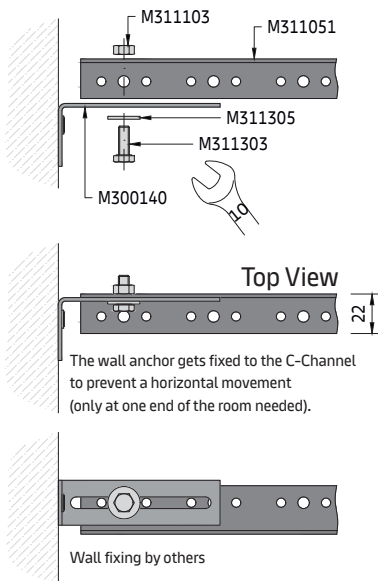

Option B2

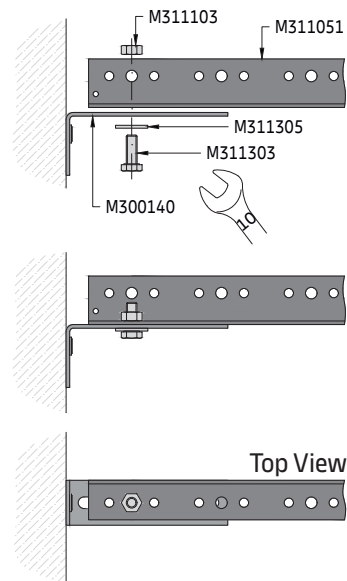

Detail C

Splice connection

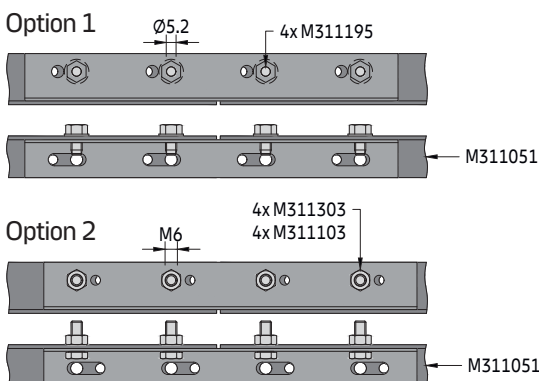

The splice connector is placed between the two ends of the primary angles. It was designed in such a way that the threaded rod can always be placed, even when there is a splice connector.

Option 1

Take four thread cutting screws and fix the splice connector to the primary angles. Use the smaller holes.

Option 2

Take four M6 bolts and nuts and fix the splice connector to the primary angles. Use the bigger M6 holes.

Primary Angle Primary Grid

C04

Primary grid components

Standard components

- M311051 Primary angle 27 x 22 mm
- M311052 Primary angle 50 x 22 mm
- M311053 Splice connector for primary angle
- M300140 Wall anchor
- M311103 Hexagonal nut M6
- M311105 Washer
- M311303 Hexagonal bolt M6 x 16 mm
- M311195 Thread cutting screw M6 x 10 mm
- M311101 Threaded rod M6 x 1000 mm
- M311315 Hexagonal extension nut M6 x 30 mm (optional)
- M311061 Suspension element (optional)

Detail D

Suspension detail

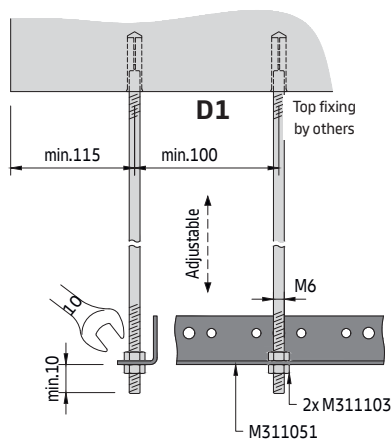

Detail D1

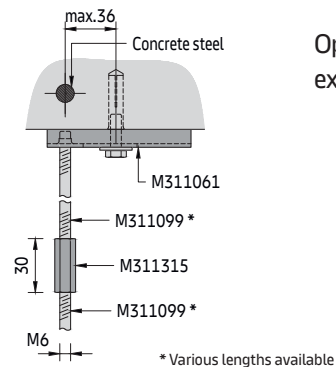

Optional top fixing and extension detail

The suspension point should always be chosen close to the crossing point of the primary and secondary grid (a5) in order to absorb the ceiling load as best as possible and to prevent the primary angle from potentially deflecting.

Minimum pull-out force per suspension point = 1.25 kN (failure state)

Maximum permissible load per suspension point = 0.50 kN (incl. 2.5 times safety). These values must always be observed and guaranteed by the installation company for each suspension point irrespective of the type of hanger selected.

General installation sequence

- 1 The position of the suspension points must be marked on the soffit before installation (laser, measuring tape, chalk line, etc.). Then drill the holes and place the top fixing (not offered by Knauf Ceiling Solutions).
- 2 Set threaded rods, cut to length if necessary.
- 3 Wherever possible, fixing should begin on the centre axis of the ceiling area.
- 4 Align the wall angle with the laser (lower edge of the visible side of the ceiling components) and attach to the boundary walls.
- 5 Fasten the primary angle to the threaded rod using two hexagonal nuts and align the height.
- 6 Primary angle should be aligned with each other and joints should be offset. Couple the primary angles with splice connectors and fix them to the boundary walls with the wall anchor at one end of each row of primary angle.
- 7 See secondary grid pages for further steps.
- 8 Lay full ceiling elements, followed by cut or full perimeter elements.
- 9 Service integrations and additional loads must be suspended separately from the soffit. The additional measures must be carried out professionally.

DP12 A-BAR PRIMARY GRID

Primary grid solution for indoor applications

General information

- Primary grid concept for small, medium and large rooms, with a minimum number of components
- For perpendicular double layer installation with DP12 A-Bar secondary grid
- All standard items are held in stock
- Tried and tested solution with extensive experience

Isometric view

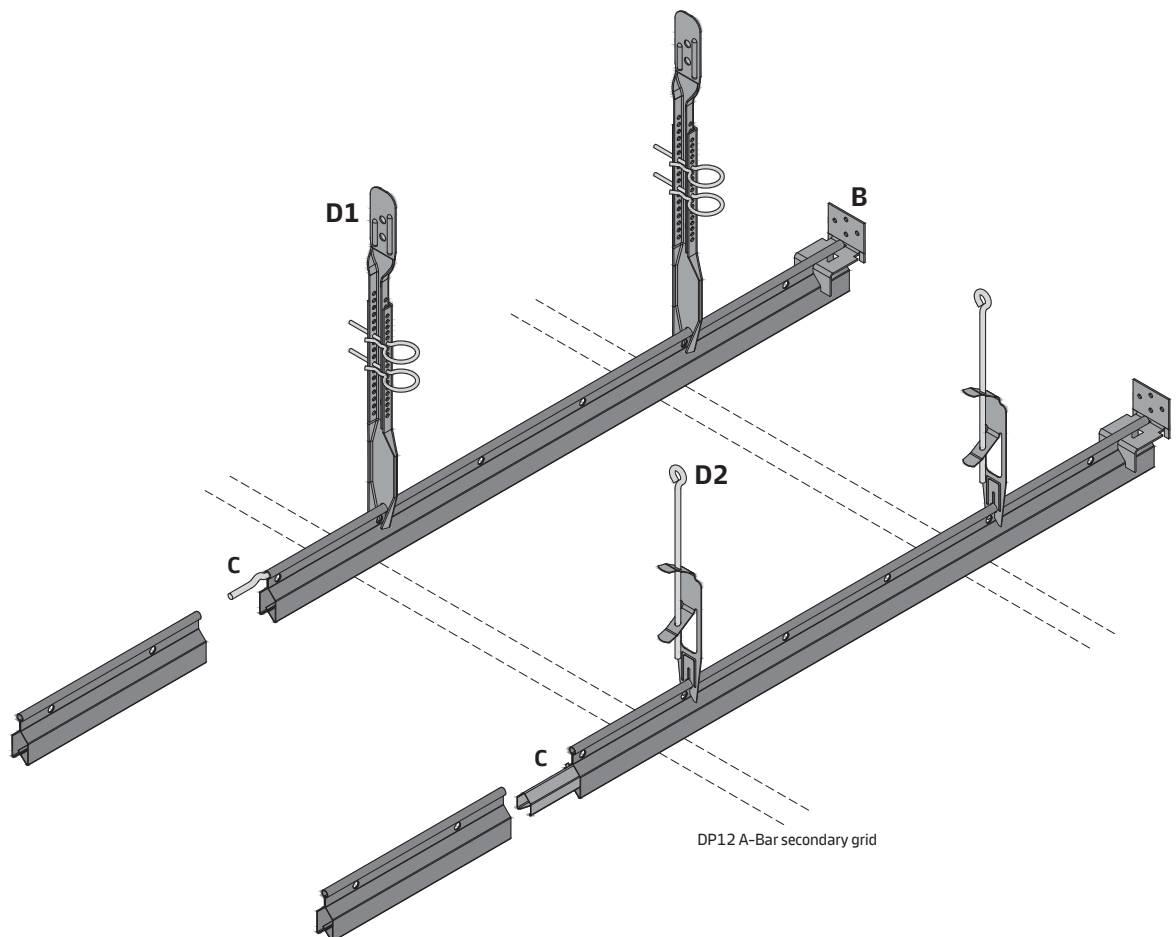

Important information

The DP12 A-Bar system fulfils the two conditions required in the European standard (EN 13964) concerning load-bearing capacity (2.5 times the failure criterion) and performance capability (deflection restriction).

DP12 A-Bar Primary Grid C05

Section A

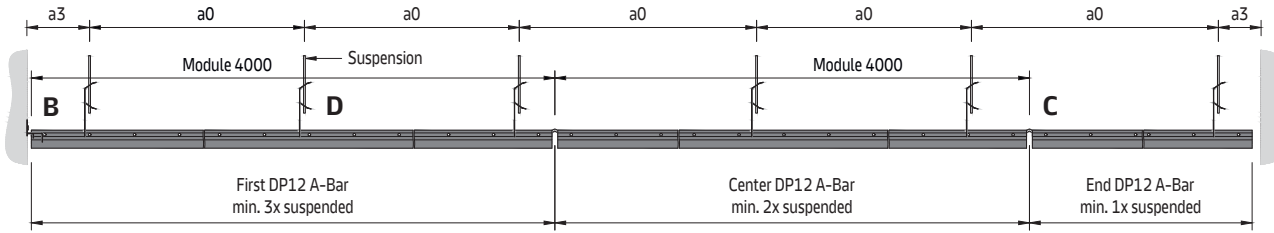

Typical grid layout

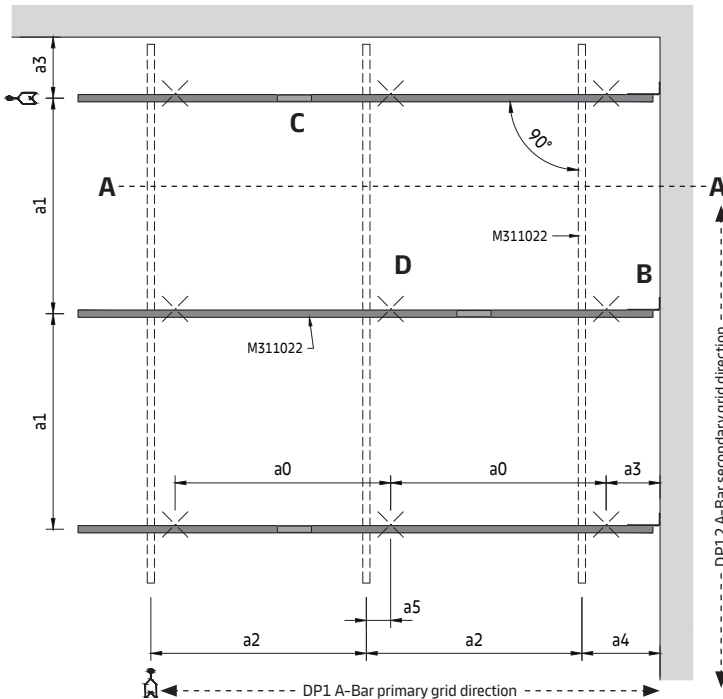

Parameters

- a0 Distance between DP12 A-Bar suspension points = max. 1900 mm
- a1 Max. distance between DP12 A-Bar
- a2 Distance between secondary grid
- a3 Distance from wall = max. 200 mm
- a4 Distance from wall = max. panel length
- a5 Distance from DP12 A-Bar suspension point to hanger = max. 100 mm

The required distances are shown in combination with the secondary grid and will vary depending on the system chosen.

Primary grid components

Standard components

- M311022 DP12 A-Bar
- M300138 Connection pin for DP12 A-Bar
- M311024 Wall anchor for DP12

Suspension option D1

- M311338 Nonius hanger for DP12 A-Bar
- - Nonius top part (various lengths)
- M300036 Nonius locking pin

Suspension option D2

- M311026 Rapid hanger for DP12 A-Bar
- - Eye wire (various lengths)

Optional components

- M311023 Splice connector for DP12 A-Bar

DP12 A-Bar

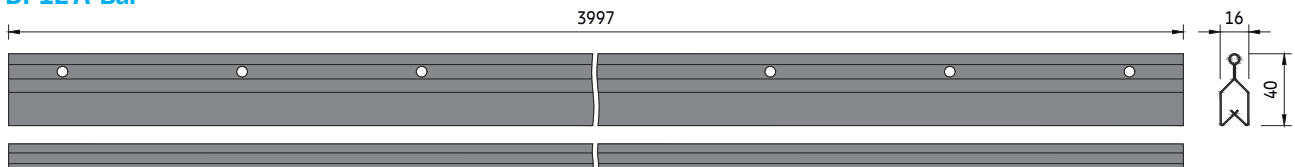

DP12 A-Bar Primary Grid C05

DP12 A-Bar alignment

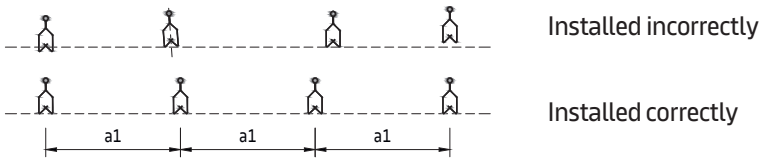

The DP12 A-Bars should be installed vertically and on the same level, in a max. distance of (a1).

Detail B

Wall fixing

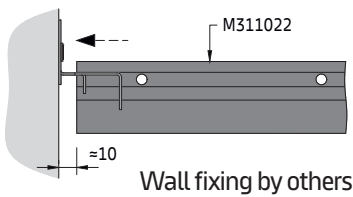
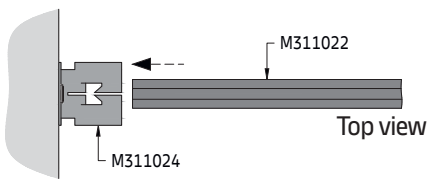

The wall anchor gets fixed to the DP12 A-Bar to prevent a horizontal movement (only at one end of the room needed).

The wall anchor prevents the DP12 A-Bar from swinging and thus contributes to the safe installation of the substructure. The wall anchor has no load-bearing function and is only attached to one end of the room to secure the DP12 A-Bar. Slide the DP12 A-Bar into the wall anchor and keep some distance to the wall.

Detail C

Splice connection

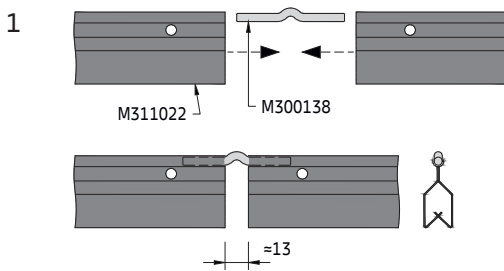

Insert the connection pin at the ends of the DP12 A-Bars and connect them. There is a gap between the DP12 A-Bars. The DP12 A-Bars must be aligned so that the joint is not in the same place as the pips on the tiles.

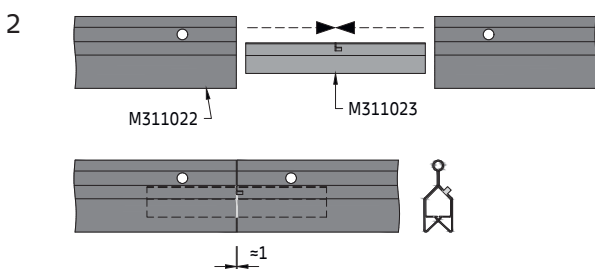

Optionally, the splice connector for DP12 A-Bar can be used. This is inserted at the ends of the DP12 A-Bars and an almost seamless connection is created.

DP12 A-Bar Primary Grid
C05

Detail D

Suspension options

Option D1

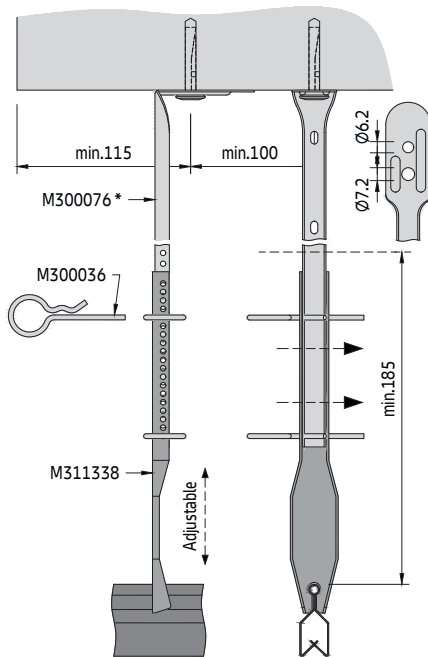

The suspension point should always be chosen close to the crossing point of the primary and secondary grid (a5) in order to absorb the ceiling load as best as possible and to prevent the DP12 A-Bar from potentially deflecting.

Minimum pull-out force per suspension point = 1.25 kN (failure)
Maximum permissible load per suspension point = 0.50 kN (incl. 2.5 times safety).

These values must always be observed and guaranteed by the installation company for each suspension point irrespective of the type of hanger selected.

*Various lengths available

Option D2

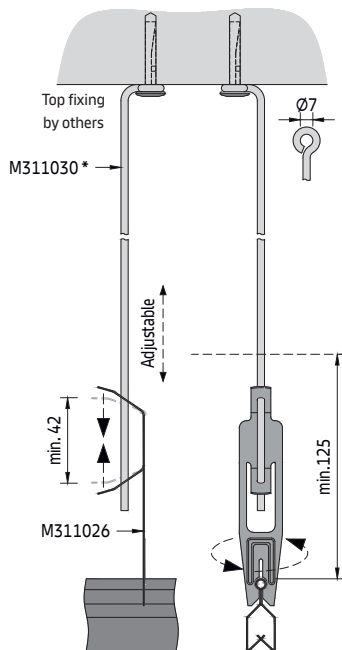

The clip should only be compressed as indicated to avoid possible damage.

DP12 A-Bar Primary Grid

C05

General installation sequence

- 1 The position of the suspension points must be marked on the soffit before installation (laser, measuring tape, chalk line, etc. Then drill the holes and place the top fixing (not offered by Knauf Ceiling Solutions).
- 2 Set Nonius top parts or eye wires.
- 3 Wherever possible, fixing should begin on the centre axis of the ceiling area.
- 4 Align the wall angle with the laser (lower edge of the visible side of the ceiling components) and attach to the boundary wall
- 5 Suspension options:
 - D1** - Position the Nonius bottom part on the DP12 A-Bar and fasten it to the Nonius top-part with two safety clips.
 - D2** - The rapid hanger for DP12 A-Bar is made of spring steel and is therefore elastic. It is twisted on the DP12 A-Bar from above. Position the rapid hanger on the DP12 A-Bar and fasten it to the eye wire.
- 6 The minimum installation height is depending on the selected suspension option **E1 - E2**. DP12 A-Bars should be aligned with each other and joints should be offset. Couple the DP12 A-Bars with splice connectors or connection pins and fix them the boundary walls with the wall anchor at one end of each row of DP12 A-Bars.
- 7 See secondary grid pages for further steps.
- 8 Lay full ceiling elements, followed by cut or full perimeter elements.
- 9 Service integrations and additional loads must be suspended separately from the soffit. The additional measures must be carried out professionally





HURACAN COFFEE



MESH Board
Huracán Coffee, Vilnius, Lithuania © Szymon Polanski



Exposed Grid Ceilings

MESH Board / MESH MicroLook / MESH Tegular

15 or 24 mm T-grid

Exposed grid solution for indoor application

General information

- Exposed lay-in grid system for small, medium and large rooms
- Typical ceiling weight 5.0 - 6.0 kg/m² (indicative value for tiles, without additional load)
- Tiles are easily installed and fully demountable
- Optional hold-down clip available for MESH Board

Isometric view

Select the suspension option.

Perimeter solutions on separate datasheet.

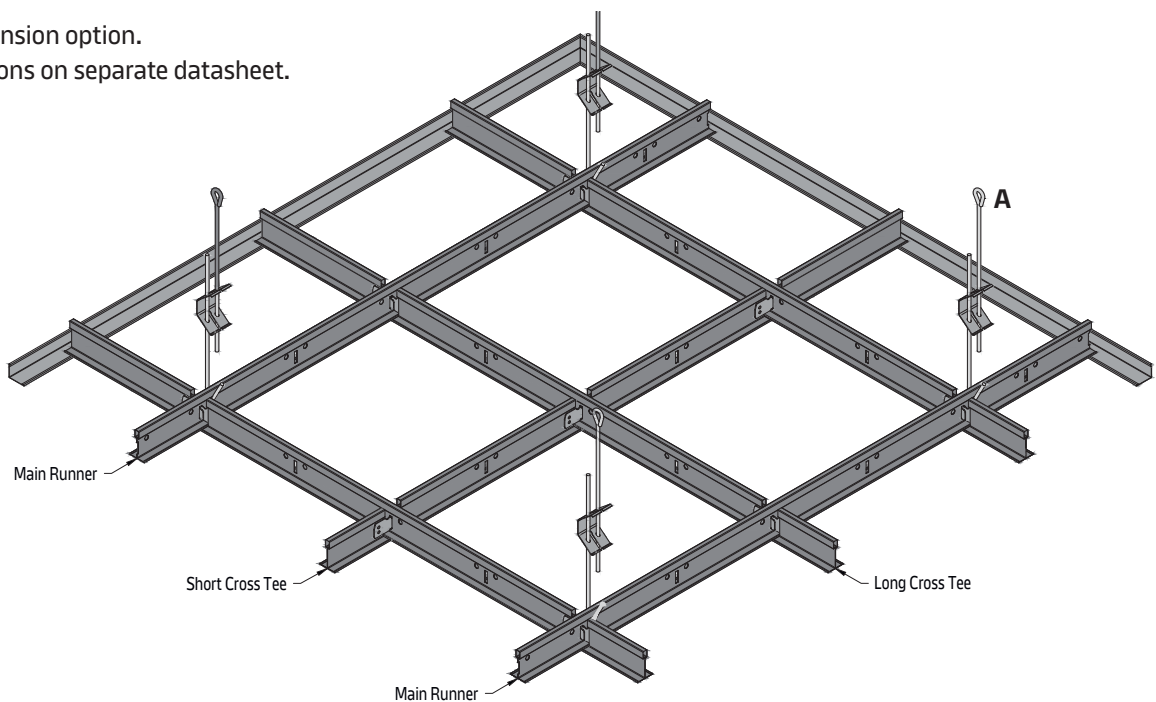

Standard & Vario Design layout options

Square tiles

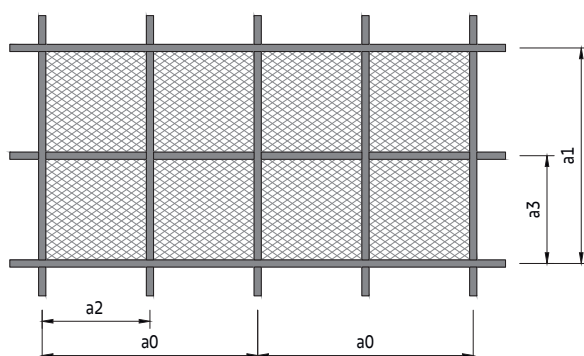

Rectangular tiles, without short Cross Tees

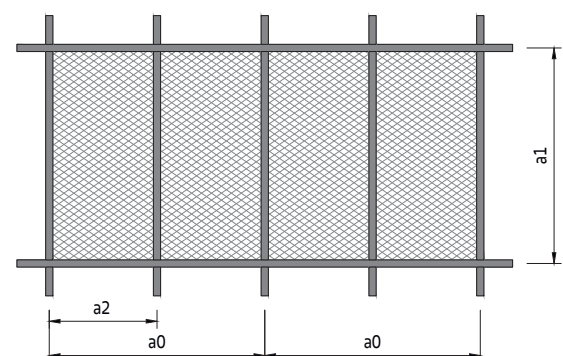

MESH Board / MESH MicroLook / MESH Tegular
D03.001

Section B

Example with MESH Board

T-grid

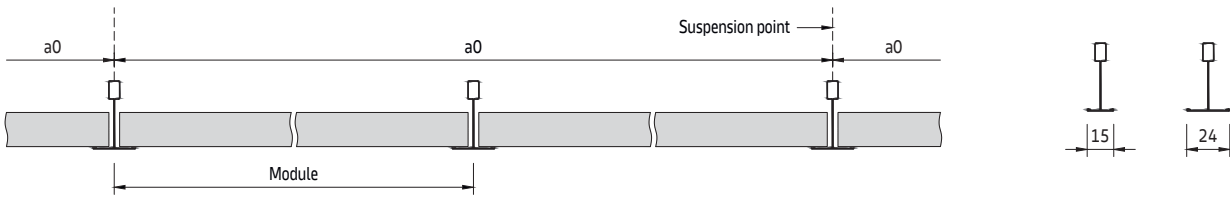

MINERAL Board

Installed on 24 mm T-grid,
butt-cut (System C)

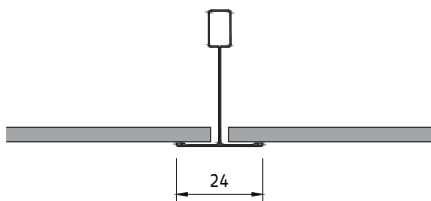

MESH MicroLook 8

Tiles with ≈ 8 mm drop
Installed on 15 mm T-grid (System C)

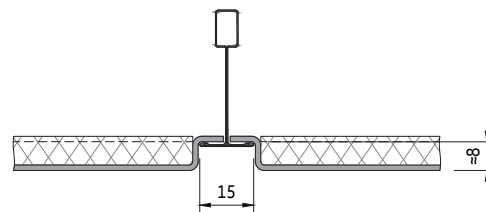

MESH Tegular 8

Tiles with ≈ 8 mm drop
Installed on 24 mm T-grid (System C)

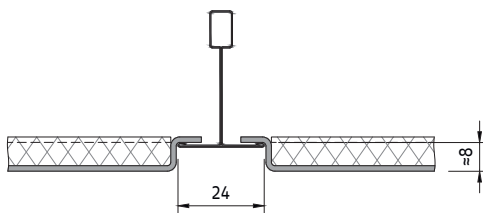

MESH Tegular 14

Tiles with ≈ 14 mm drop
Installed on 24 mm T-grid (System C)

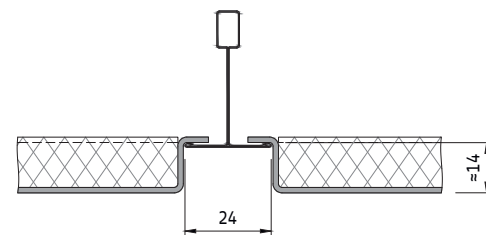

Optional grid components

Components

- CHDC Hold-down clip

See Main Runner for grid components

MESH Board / MESH MicroLook / MESH Tegular
D03.001

Typical grid layout

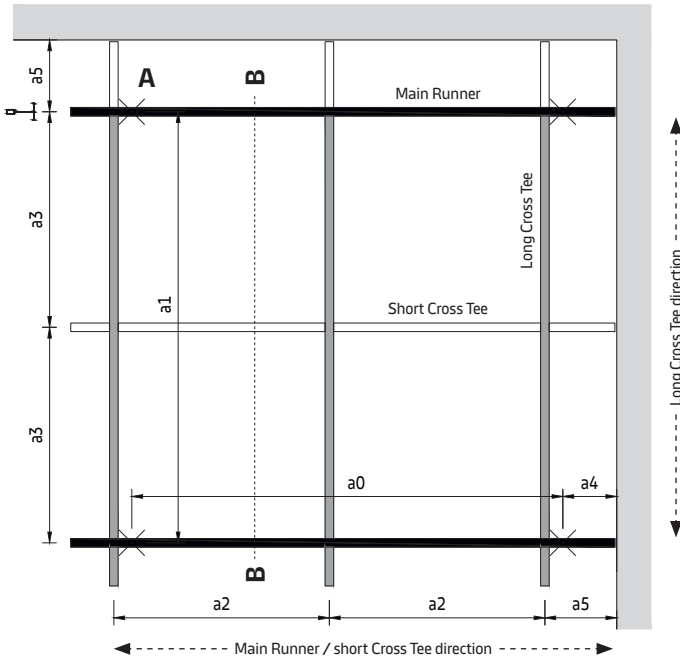

Parameters

- a0 Max. distance between Main Runner suspension points
- a1 Distance between Main Runner
- a2 Distance between Cross Tees (module width)
- a3 Distance between Cross Tees (module length)
- a4 Distance from wall = max. 200 mm
- a5 Distance from wall = max. module length / width, (min. 1/2 module length / width is recommended)

Spacing

a2 [mm]	System without additional load		System with additional load +4kg/m ²	
	a0 [mm]	a1 [mm]	a0 [mm]	a1 [mm]
600	1500	1200	1200	1200
625	1500	1250	1200	1250

Start with the module width / distance between the long Cross Tees (a2) and take the values for (a0) and (a1) next to it. The shown values for (a0) are maximum allowed distances.

MESH Board tiles storage & handling

Wrong storage

Correct storage

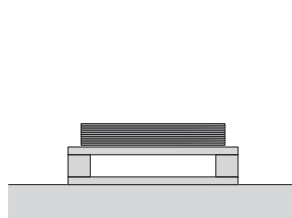
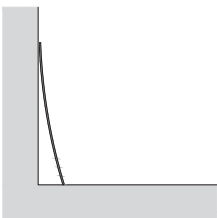

Wrong handling

Correct handling



MESH Board tile

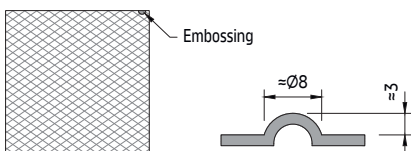

Hold-down clip option

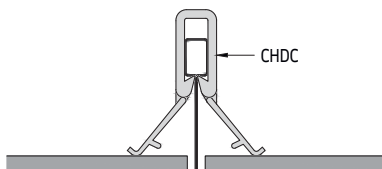

MESH Board tiles are supplied as flat sheets without an upstand, lying flat in a box. The tiles should always be stored on site lying flat on a level surface. It is best to leave them in the box until they are installed. The tiles should not be stored standing up against the wall, otherwise they could warp. Use both hands when removing the tiles from the box. When using one hand, the weight can cause the corner to deform. After installation, the tiles would not lie flat on the T-Grid.

Depending on the mesh type, it is difficult to recognise the direction of the pattern and the visible side. Therefore, the tiles are provided with an embossing in the corner. The tiles should always be laid with the embossing facing up and pointing in the same direction. The embossing is not visible after installation.

If the tiles have become slightly deformed due to improper handling, a hold-down clip can be used to improve this. The hold down clip option can be used to apply light pressure to the top of the tiles. This is not a security clip solution. Using the clip makes inserting and extracting the tiles more difficult.

MESH Board / MESH MicroLook / MESH Tegular
D03.001

Detail C

Example with MINERAL Board

Tile insertion

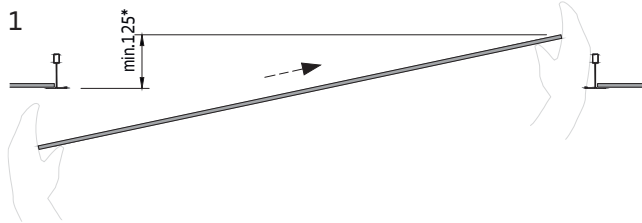

Insert the tile diagonally. The minimum recommended installation height is 125 mm, depending on the edge detail, module size and selected suspension method.



Place it on the T-grid.



Tile extraction

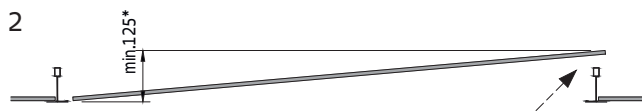

Lift the tile in one corner.



Remove it diagonally downwards.

Material required per m² (no waste included)

System without additional load

Components	Module [mm]	600 x 600	625 x 625	1200 x 600
Main Runner	[m/m ²]	0.84	0.80	0.84
Long Cross-Tee	[m/m ²]	1.67	1.60	1.67
Short Cross-Tee	[m/m ²]	0.84	0.80	0
Suspension points (A)	[pcs/m ²]	0.56	0.54	0.56

The shown quantities are theoretical and based on an ideal layout, without considering the actual room layout. The ideal layout is based on a calculation of 10 x 10 m (100 m²). This calculation does not allow any damage, spare nor wastage. The final quantities and type of suspension have to be checked before ordering. Soffit and wall fixings by others. Not including perimeter trims.

MESH R-L 201 / MESH R-L 201 MT

U-Profile primary grid + L-Profile secondary grid
Exposed grid solution for indoor applications

General information

- Exposed lay-in grid system for medium and large rooms
- For perpendicular installation on U-Profile primary grid
- L-Profile 38 mm in RAL 9010 made of aluminium (colour options on request)
- Typical ceiling weight 8.0 – 9.5 kg/m² (indicative value for panels, without additional load)
- Panels are easily installed and fully demountable
- MESH R-L 201 MT Megapanel option (up to 1200 x1202 mm)

Isometric view

Select the suspension option E1 - E4.
Perimeter solutions on separate datasheet.

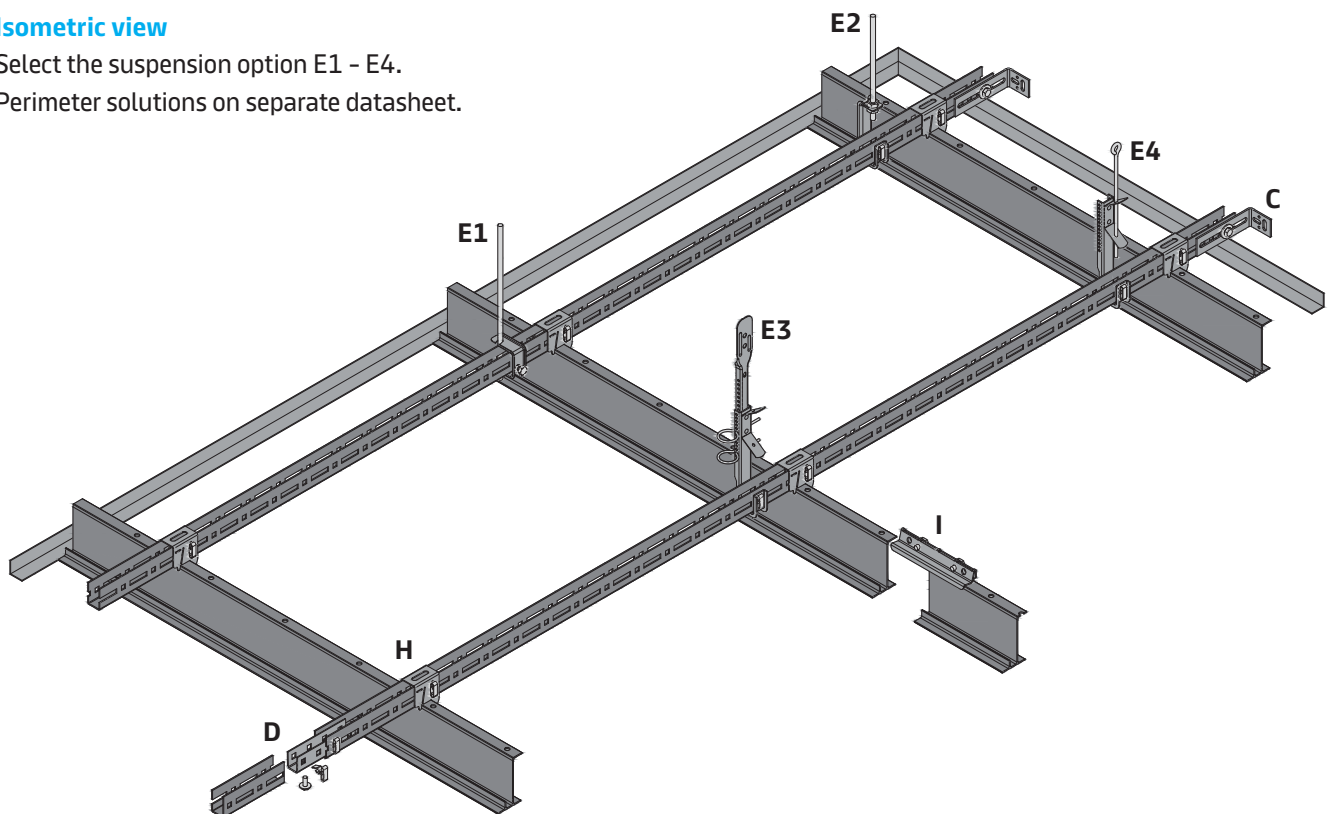

Vario Design & bespoke layout options

Vario Design

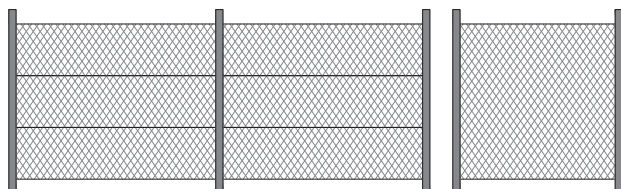

Bespoke (on request)

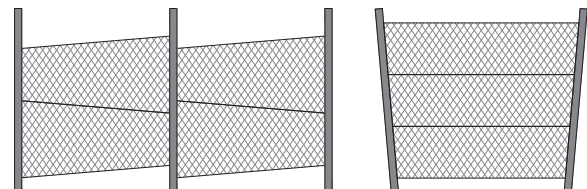

MESH R-L 201 / MESH R-L 201 MT
D03.002

Section F (MESH R-L 201)

Example with suspension option E1

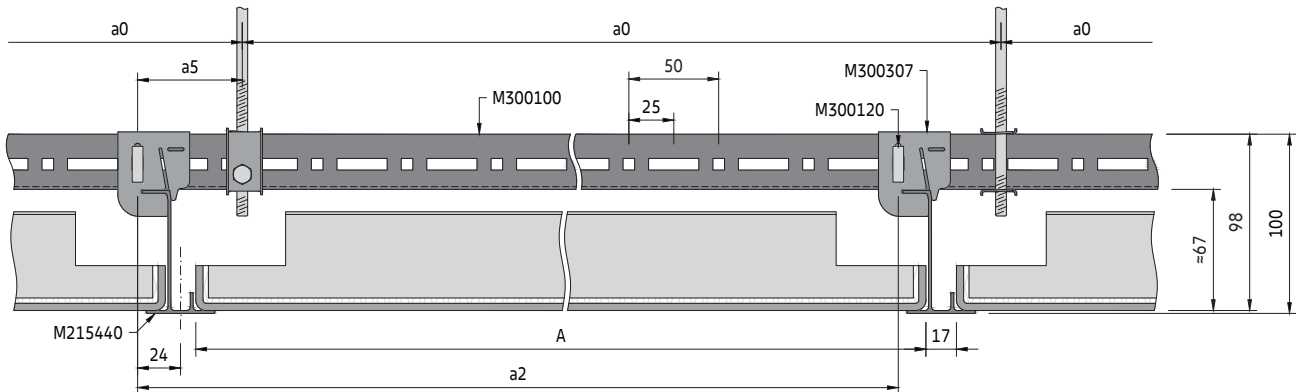

Section F (MESH R-L 201 MT)

Example with suspension option E1

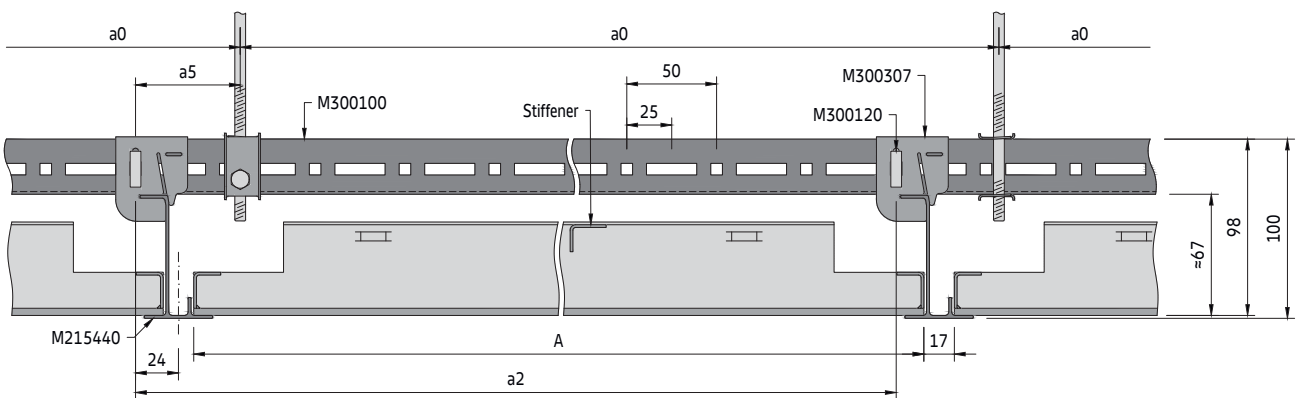

Panels >2000 mm length with additional welded stiffener

Secondary grid components

Standard components:

- M215440 L-Profile RAL 9010
- M300343 Splice connector for L-Profile
- M300307 Hanger for L-Profile
- M300120 Plug-in clip for U-Profile

Optional components:

- M311191 Self-drilling screw 3.5 x 9.5 mm

See U-Profile primary grid for primary grid components

L-Profile secondary grid

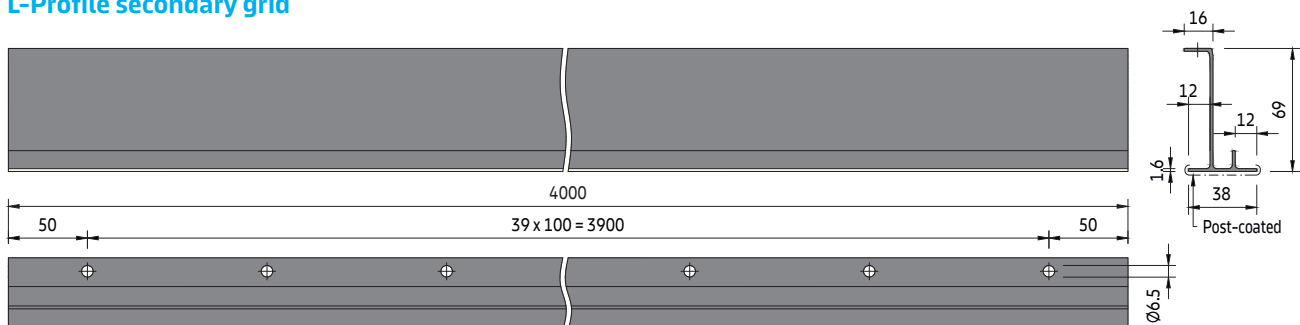

MESH R-L 201 / MESH R-L 201 MT
D03.002

Section G (MESH R-L 201)

Example with suspension option E1

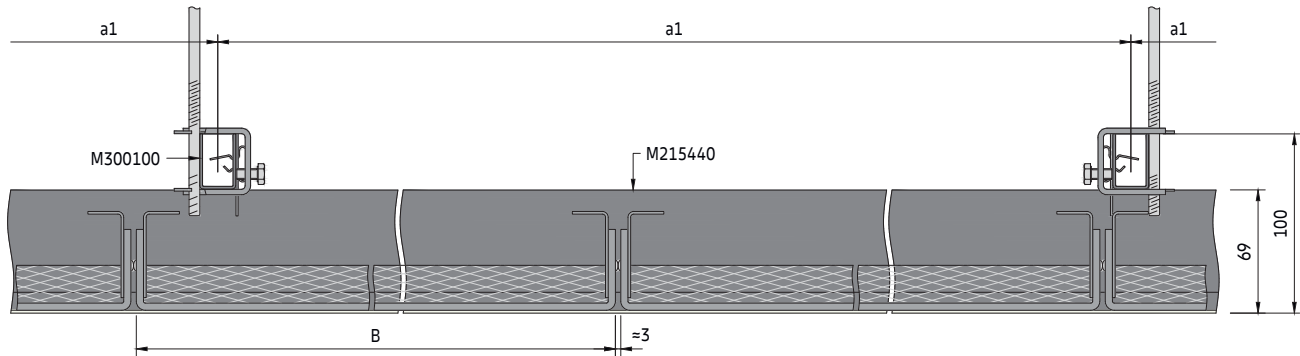

The panels should be installed with a ≈ 3 mm open gap on the long side, which enables installation.

Section G (MESH R-L 201 MT)

Example with suspension option E1

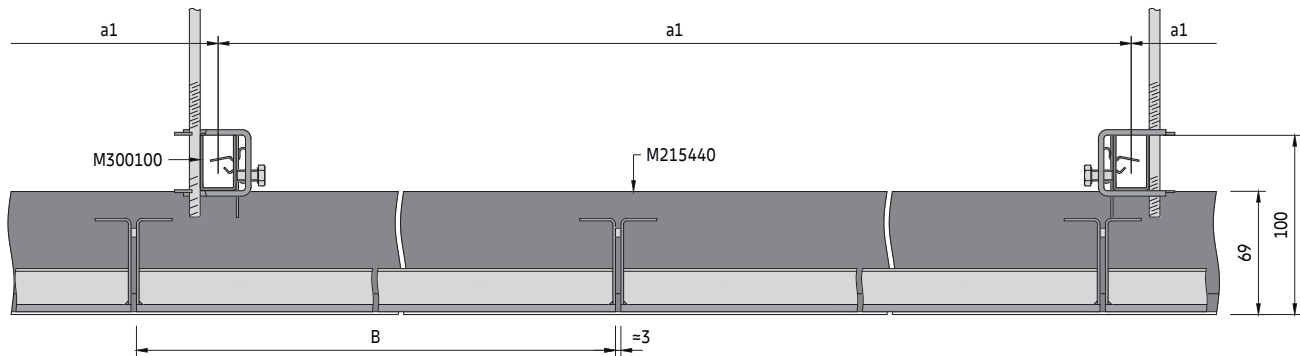

The panels come standard with a ≈ 3 mm spacer on the long side.

Material required per m² (no waste included)

System without additional load [pcs/m²]

Components	a2 [mm]	1200	1600	1800	2000	2200	2500
M215440	L-Profile RAL 9010	0.21	0.16	0.14	0.13	0.12	0.10
M300100	U-Profile	0.15	0.24	0.33	0.19	0.21	0.21
M300119	Splice connector for U-Profile	0.15	0.25	0.34	0.20	0.21	0.22
M300120	Plug-in clip for U-Profile	0.15	0.25	0.38	0.76	0.77	0.76
M300140	Wall anchor	0.06	0.10	0.13	0.80	0.08	0.09
M300307	Hanger for L-Profile	0.47	0.57	0.70	0.36	0.35	0.32
M300343	Splice connector for L-Profile	0.21	0.16	0.14	0.13	0.12	0.10
M311103	Hexagonal nut M6	0.10	0.10	0.10	0.10	0.10	0.10
M311105	Washer	0.10	0.10	0.10	0.10	0.10	0.10
M311303	Hexagonal bolt M6 x 16 mm	0.10	0.10	0.10	0.10	0.10	0.10
Various	Suspension points (E1 - E4)	0.47	0.57	0.70	0.72	0.70	0.64

The shown quantities are theoretical and based on an ideal layout, without considering the actual room layout. The ideal layout is based on a calculation of 10 x 10 m (100 m²). This calculation does not allow any damage, spare nor wastage. The final quantities and type of suspension have to be checked before ordering. Soffit and wall fixings by others. Not including perimeter trims, optional security brackets and extraction tools.

MESH R-L 201 / MESH R-L 201 MT
D03.002

Spacing

a2 [mm]	System without additional load		System with additional load +4 kg/m²	
	a0 [mm]	a1 [mm]	a0 [mm]	a1 [mm]
600	1200	1900	1200	1450
650	1300	1700	1300	1200
700	1400	1450	1400	1050
750	1500	1250	750	1900
800	1600	1100	800	1900
850	850	1900	850	1900
900	900	1900	900	1900
950	950	1900	950	1850
1000	1000	1900	1000	1800
1050	1050	1900	1050	1750
1100	1100	1850	1100	1700
1150	1150	1800	1150	1600
1200	1200	1800	1200	1450
1250	1250	1750	1250	1350
1300	1300	1700	1300	1250
1350	1350	1600	1350	1150
1400	1400	1500	1400	1050
1450	1450	1400	1450	1000
1500	1500	1300	1500	900
1550	1550	1200	1550	800
1600	1600	1100	1600	800
1650	1650	1050	1650	750
1700	1700	1000	1700	700
1750	1750	900	1750	650
1800	1800	800	900	1350
1850	925	1450	925	1300
1900	950	1400	950	1300
1950	975	1400	975	1300
2000	1000	1400	1000	1250
2050	1025	1350	1025	1250
2100	1050	1350	1050	1250
2150	1075	1350	1075	1200
2200	1100	1300	1100	1200
2250	1125	1300	1125	1200
2300	1150	1300	1150	1200
2350	1175	1300	1175	1150
2400	1200	1250	1200	1150
2450	1225	1250	1225	1150
2500	1250	1250	1250	1150

Parameters

- a0 Distance between U-Profile suspension points = max. 1900 mm
- a1 Max. distance between U-Profiles
- a2 Distance between L-Profiles = panel length + 17 mm
- a3 Distance from wall = max. 200 mm
- a4 Distance from wall = max. panel length
- a5 Distance from U-Profile suspension point to hanger = max. 100 mm
- M Module size = panel length + 17 mm / panel width + ≈3 mm gap
- A Panel length = min. 597 / max. 2500 mm *
- B Panel width = min. 247 / max. 700 mm *

* The dimensions depend on the chosen system and mesh pattern

Typical grid layout

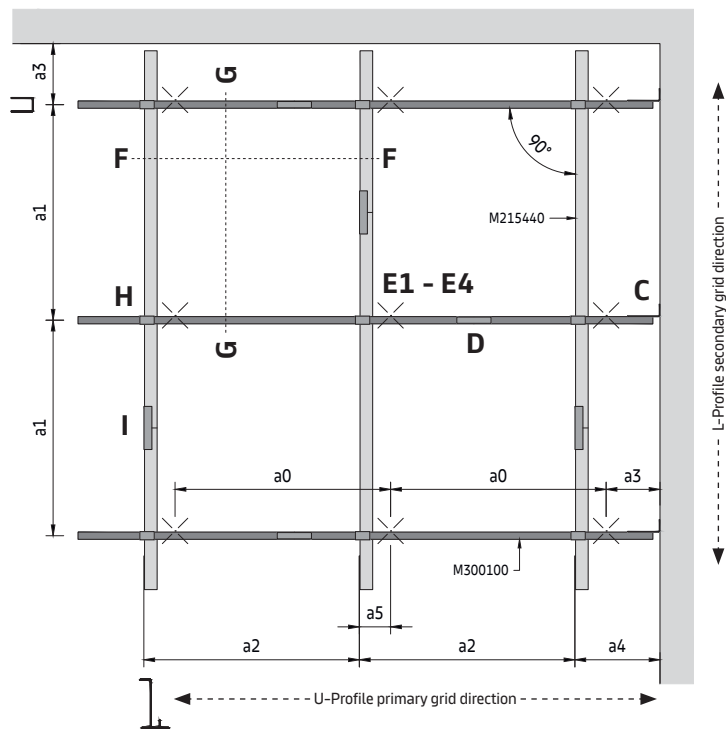

To determine suspension layout

The module length (M) of the requested ceiling is equal to the distance between the L-Profile centres (a2).

On the appropriate spacing table, read down the column headed (a2) to the required module length then read across to determine the suspension point spacing (a0) and U-Profile spacing (a1).

The shown values are maximum allowed distances and can be reduced but not exceeded.

MESH R-L 201 / MESH R-L 201 MT
D03.002

Detail H

Hanger installation

- 1 Place the hanger on the U-profile.

- 2 Fix hanger with plug-in clips at the specified module spacing (inserted vertically or horizontally). If the panel size does not fit with the modulation of the U-Profile (25 mm increments), the plug-in clip needs to be inserted into a long hole. The hanger position can alternatively be fixed by using a pop-rivet or self-drilling screw.

- 3 Insert the L-Profile into the hanger, press down the two hanger wings to lock the position of the L-Profile.

- 4 The L-Profile is now locked in position.

Detail H

Splice connection

- 1 Once the L-Profiles are installed under the U-Profiles, the ends should be brought together without a gap.

- 2 The connectors for the L-Profiles must be inserted from above.

- 3 Use the bolts to secure the connector. Stagger the joints.

MESH R-L 201 / MESH R-L 201 MT
D03.002

Detail J

Panel insertion (example with MESH R-L 201)

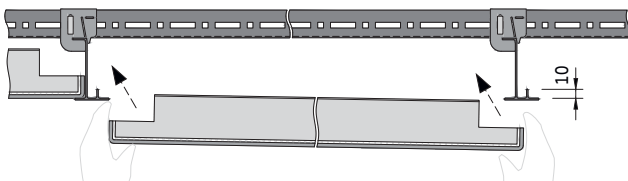
- 1  The L-Profile was designed asymmetrically with an additional upstand of 10 mm. As a result, the panels are a little shorter and require less height when installing and extracting.

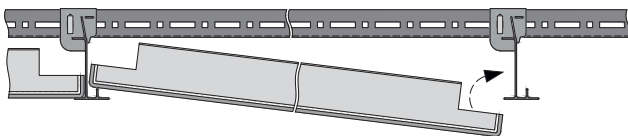
- 2  Insert the panel first on the side where the upstand of the L-Profile is, followed by the opposite side.

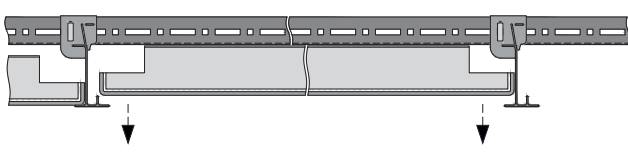
- 3  The panel is placed horizontally on the L-Profiles.

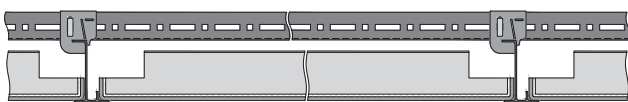
- 4  Continue with the next panel.

Panel extraction (example with MESH R-L 201)

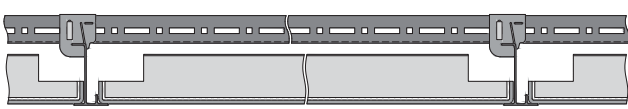
- 1  With a closed ceiling, any panel can be removed as long as there are no obstacles such as service integrations, etc.

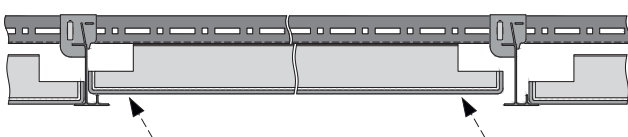
- 2  Lift the panel and move it to the direction where the L-Profile upstand is.

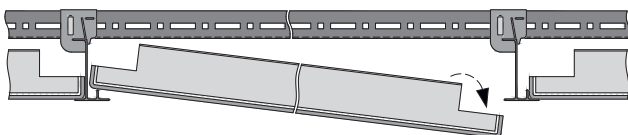
- 3  Lower the opposite side.

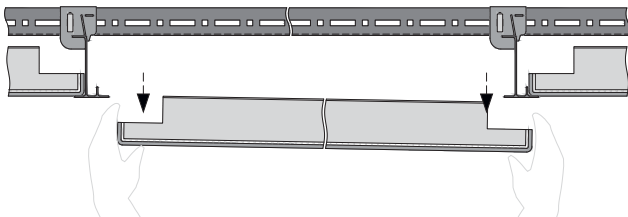
- 4  Remove it downwards and store the panel in a safe place so that it cannot be damaged.

MESH R-L 201 / MESH R-L 201 MT

Primary angle primary grid + L-Profile secondary grid
Exposed grid solution for indoor applications

General information

- Exposed lay-in grid system for medium and large rooms
- For perpendicular or radial installation on primary angle primary grid (27 x 22 / 50 x 22 mm option)
- L-Profile 38 mm in RAL 9010 made of aluminium (colour options on request)
- Typical ceiling weight 8.0 – 9.5 kg/m² (indicative value for panels, without additional load)
- Panels are easily installed and fully demountable
- MESH R-L 201 MT Megapanel option (up to 1200 x 1202 mm)

Isometric view

Example with primary angle 27 x 22 mm
Perimeter solutions on separate datasheet.

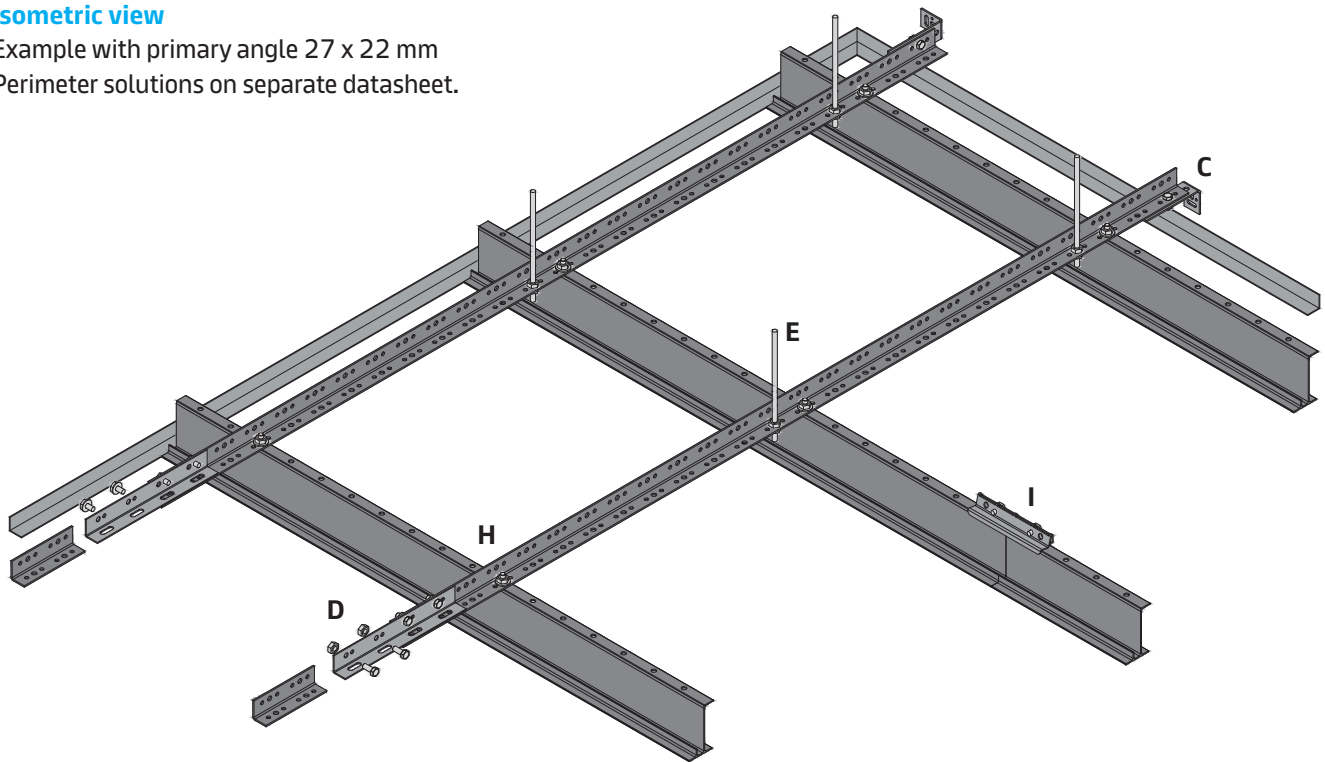

Vario Design & bespoke layout options

Vario Design

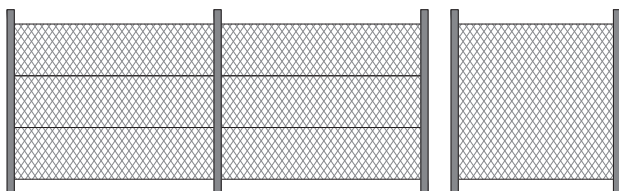

Bespoke (on request)

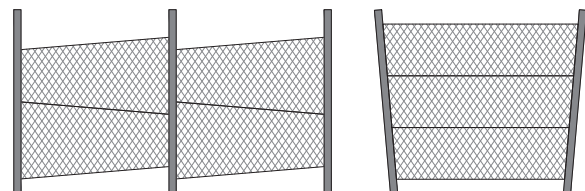

MESH R-L 201 / MESH R-L 201 MT

D03.002.1

Section F (MESH R-L 201)

Example with primary angle 27 x 22 mm

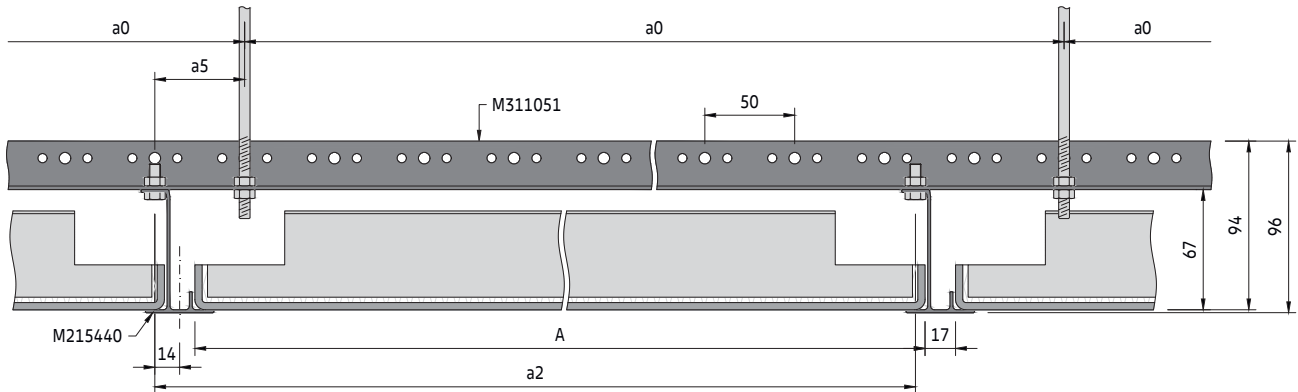

Section F (MESH R-L 201 MT)

Example with primary angle 27 x 22 mm

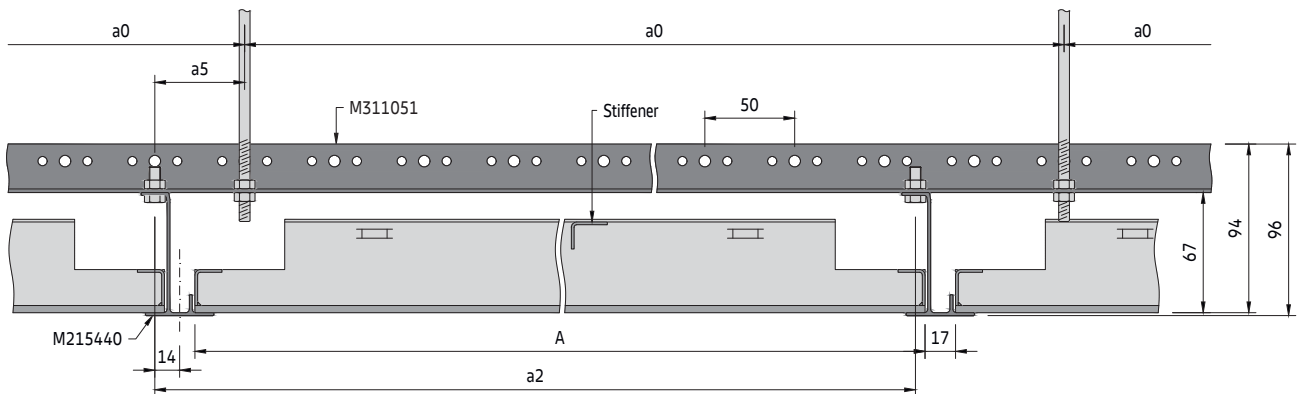

Panels >2000 mm length with additional welded stiffener.

Secondary grid components

Standard components:

- M215440 L-Profile RAL 9010
- M300343 Splice connector for L-Profile

See primary angle primary grid for primary grid components.

L-Profile secondary grid

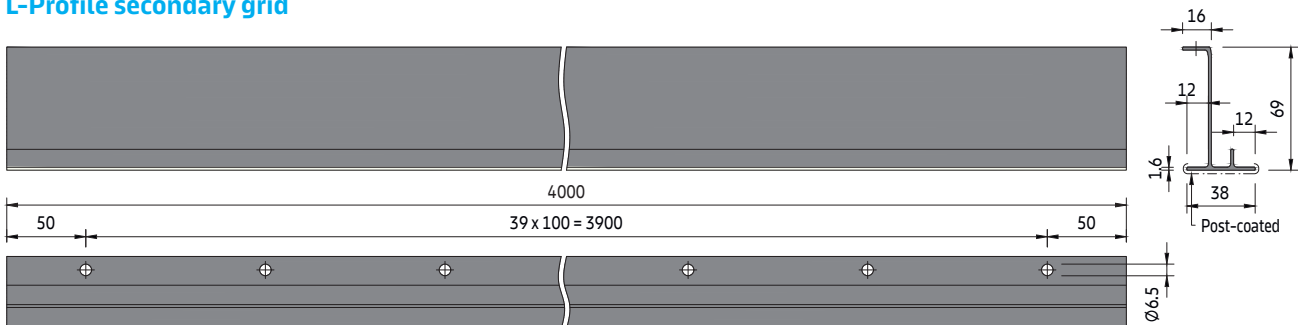

MESH R-L 201 / MESH R-L 201 MT
D03.002.1

Section G (MESH R-L 201)

Example with primary angle 27 x 22 mm

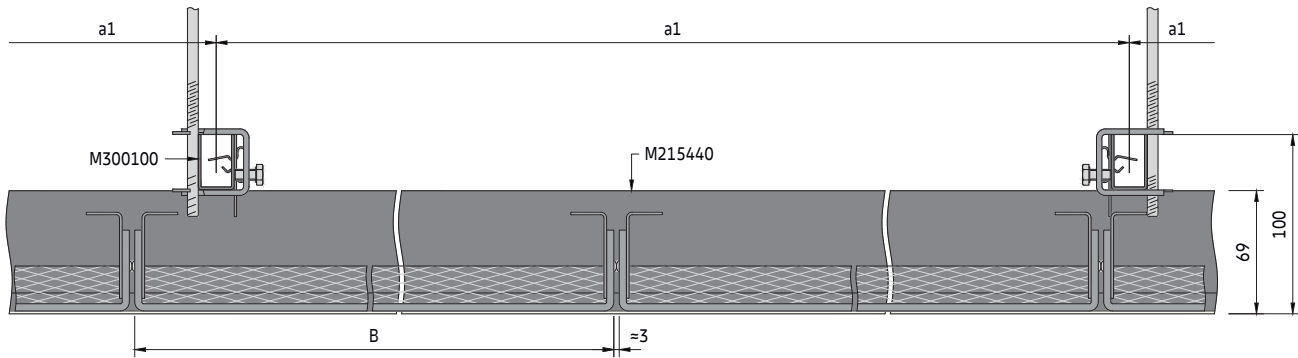

The panels should be installed with a ≈ 3 mm open gap on the long side, which enables installation.

Section G (MESH R-L 201 MT)

Example with primary angle 27 x 22 mm

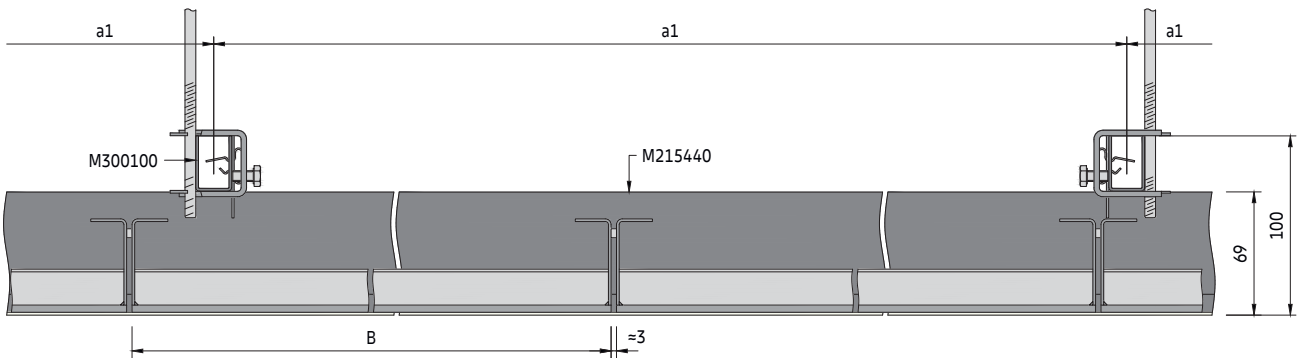

The panels come standard with a ≈ 3 mm spacer on the long side.

MESH R-L 201 / MESH R-L 201 MT
D03.002.1

Detail H

L-Profile fixing

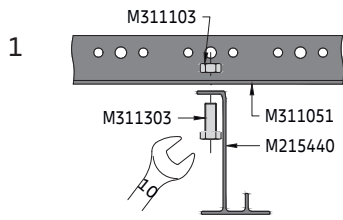

Use an M6 bolt and nut to screw the L-Profile below the primary angle.

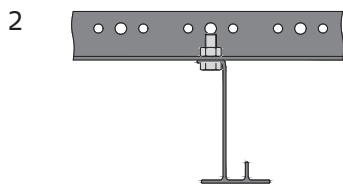

The L-Profile is now fixed.

Detail I

Splice connection

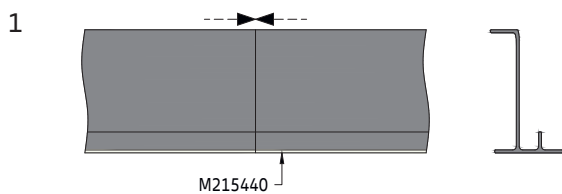

Once the L-Profiles are installed under the primary angles, the ends should be brought together without a gap.

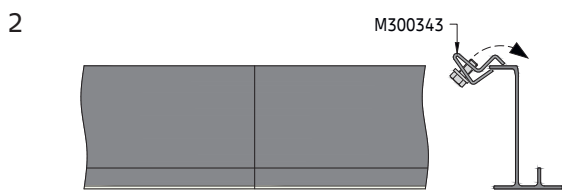

The connectors for the L-Profiles must be inserted from above.

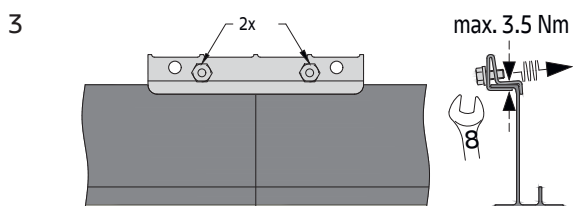

Use the bolts to secure the connector. Stagger the joints.

MESH R-L 201 / MESH R-L 201 MT
D03.002.1

Spacing for primary angle 27 x 22 mm

a2 [mm]	System without additional load		System with additional load +4 kg/m²	
	a0 [mm]	a1 [mm]	a0 [mm]	a1 [mm]
600	1200	1500	1200	1200
650	1300	1500	1300	1000
700	1400	1200	1400	750
750	1500	1200	750	1500
800	1600	1000	800	1500
850	850	1500	850	1500
900	900	1500	900	1500
950	950	1500	950	1500
1000	1000	1500	1000	1500
1050	1050	1500	1050	1500
1100	1100	1500	1100	1500
1150	1150	1500	1150	1500
1200	1200	1500	1200	1200
1250	1250	1500	1250	1200
1300	1300	1500	1300	1000
1350	1350	1500	1350	1000
1400	1400	1200	1400	750
1450	1450	1200	1450	750
1500	1500	1200	1500	750
1550	1550	1000	1550	750
1600	1600	1000	1600	750
1650	1650	750	1650	600
1700	1700	750	1700	600
1750	1750	750	1750	600
1800	1800	750	900	1200
1850	925	1200	925	1200
1900	950	1200	950	1200
1950	975	1200	975	1200
2000	1000	1200	1000	1000
2050	1025	1200	1025	1000
2100	1050	1200	1050	1000
2150	1075	1200	1075	1000
2200	1100	1000	1100	1000
2250	1125	1000	1125	1000
2300	1150	1000	1150	1000
2350	1175	1000	1175	1000
2400	1200	1000	1200	1000
2450	1225	1000	1225	1000
2500	1250	1000	1250	1000

Spacing for primary angle 50 x 22 mm

a2 [mm]	System without additional load		System with additional load +4 kg/m²	
	a0 [mm]	a1 [mm]	a0 [mm]	a1 [mm]
600	1200	1900	1200	1900
650	1300	1900	1300	1900
700	1400	1900	1400	1900
750	1500	1900	750	1900
800	1600	1900	800	1900
850	1700	1900	850	1900
900	900	1900	900	1900
950	950	1900	950	1900
1000	1000	1900	1000	1900
1050	1050	1900	1050	1900
1100	1100	1900	1100	1900
1150	1150	1900	1150	1900
1200	1200	1900	1200	1900
1250	1250	1900	1250	1900
1300	1300	1900	1300	1900
1350	1350	1900	1350	1900
1400	1400	1900	1400	1900
1450	1450	1900	1450	1900
1500	1500	1900	1500	1850
1550	1550	1900	1550	1750
1600	1600	1900	1600	1650
1650	1650	1900	1650	1550
1700	1700	1900	1700	1450
1750	1750	1850	1750	1350
1800	1800	1700	1800	1200
1850	1850	1550	925	1100
1900	1900	1450	950	1750
1950	975	1900	975	1750
2000	1000	1900	1000	1750
2050	1025	1900	1025	1700
2100	1050	1900	1050	1700
2150	1075	1900	1075	1700
2200	1100	1900	1100	1700
2250	1125	1850	1125	1650
2300	1150	1850	1150	1650
2350	1175	1850	1175	1650
2400	1200	1850	1200	1650
2450	1225	1800	1225	1600
2500	1250	1800	1250	1600

MESH R-L 201 / MESH R-L 201 MT

D03.002.1

Typical grid layout

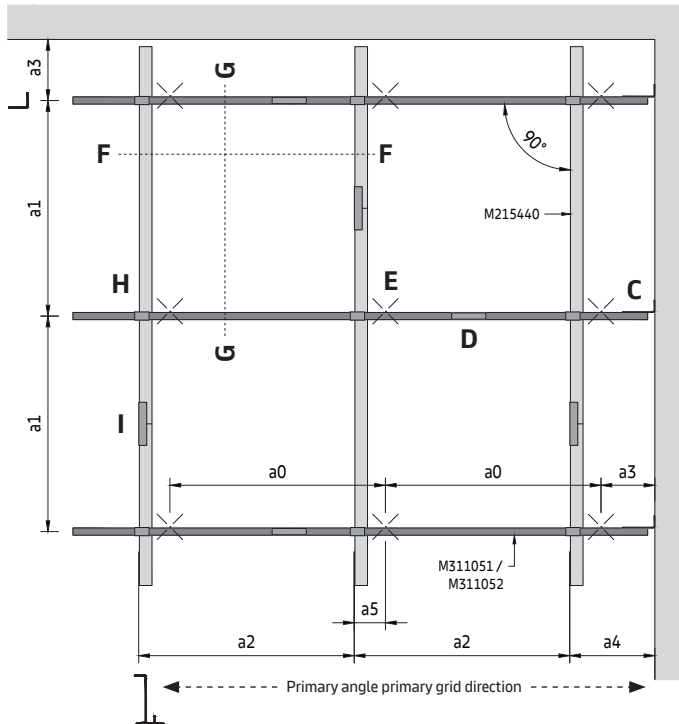

Parameters

- a0 Distance between primary angle suspension points = max. 1900 mm
- a1 Max. distance between primary angles
- a2 Distance between L-Profiles = panel length + 17 mm
- a3 Distance from wall = max. 200 mm
- a4 Distance from wall = max. panel length
- a5 Distance from primary angle suspension point to hanger = max. 100 mm
- M Module size = panel length + 17 mm / panel width + ≈3 mm gap
- A Panel length = min. 597 / max. 2500 mm *
- B Panel width = min. 247 / max. 700 mm *

* The dimensions depend on the chosen system and mesh pattern

To determine suspension layout

The module length (M) of the requested ceiling is equal to the distance between the L-Profile centres (a2).

On the appropriate spacing table, read down the column headed (a2) to the required module length then read across to determine the suspension point spacing (a0) and U-Profile spacing (a1).

The shown values are maximum allowed distances and can be reduced but not exceeded.

MESH R-L 201 / MESH R-L 201 MT
D03.002.1

Detail J

Panel insertion (example with MESH R-L 201)

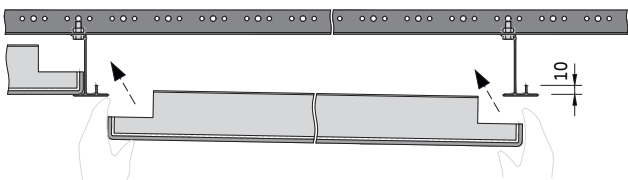
- 1  The L-Profile was designed asymmetrically with an additional upstand of 10 mm. As a result, the panels are a little shorter and require less height when installing and extracting.

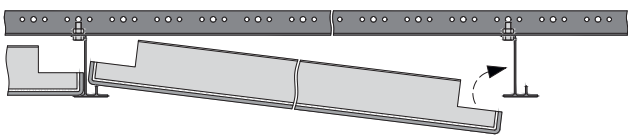
- 2  Insert the panel first on the side where the upstand of the L-Profile is, followed by the opposite side.

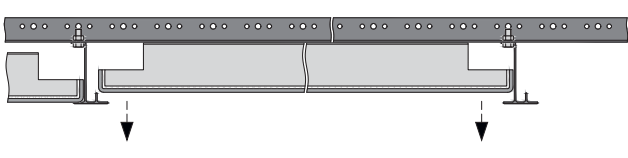
- 3  The panel is placed horizontally on the L-Profiles.

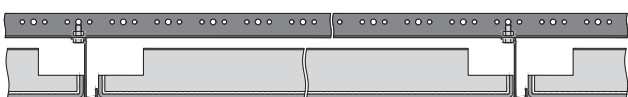
- 4  Continue with the next panel.

Panel extraction (example with MESH R-L 201)

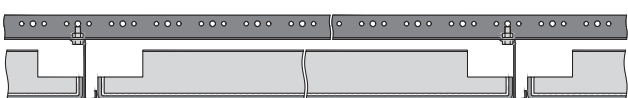
- 1  With a closed ceiling, any panel can be removed as long as there are no obstacles such as service integrations, etc.

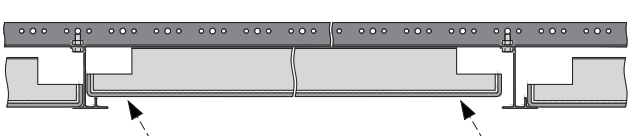
- 2  Lift the panel and move it to the direction where the L-Profile upstand is.

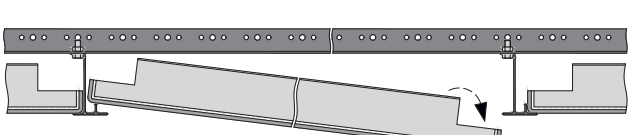
- 3  Lower the opposite side.

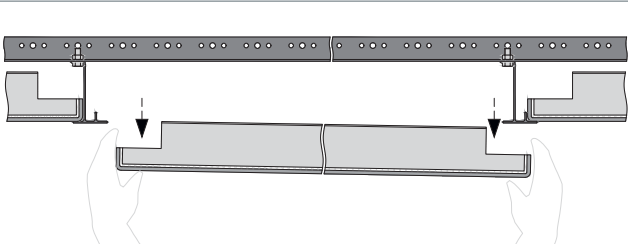
- 4  Remove it downwards and store the panel in a safe place so that it cannot be damaged.

MESH R-L 201 / MESH R-L 201 MT

D03.002.1

Material required per m² (no waste included)**System without additional load [pcs/m²]**

Components	a2 [mm]	1200	1600	1800	2000	2200	2500
M215440	L-Profile RAL 9010	0.21	0.16	0.14	0.13	0.12	0.12
M311051	Primary angle 27 x 22 mm	0.22	33.3	0.44	0.28	0.33	0.33
M311053	Splice connector for primary angle *	0.23	0.34	0.45	0.28	0.34	0.34
M300140	Wall anchor	0.07	0.11	0.14	0.09	0.11	0.11
M300343	Splice connector for L-Profile	0.21	0.16	0.14	0.13	0.12	0.12
M311099	Threaded rod M6 x 1000 mm	0.56	0.63	0.75	0.84	0.91	0.91
M311103	Hexagonal nut M6	0.16	0.21	0.27	0.21	0.24	0.24
M311105	Washer	0.10	0.10	0.10	0.10	0.10	0.10
M311303	Hexagonal bolt M6 x 16 mm	0.16	0.21	0.27	0.21	0.24	0.24

*Option with M6 bolt and nut

The shown quantities are theoretical and based on an ideal layout, without considering the actual room layout. The ideal layout is based on a calculation of 10 x 10 m (100 m²). This calculation does not allow any damage, spare nor wastage. The final quantities and type of suspension have to be checked before ordering. Soffit and wall fixings by others. Not including perimeter trims, optional security brackets and extraction tools.

MESH R-L 201 / MESH R-L 201 MT

Direct suspended L-Profile
Exposed grid solution for indoor applications

General information

- Exposed lay-in grid system for small rooms with low cavity
- For perpendicular or radial installation
- L-Profile 38 mm in RAL 9010 made of aluminium (colour options on request)
- Typical ceiling weight 7.5 - 9.0 kg/m² (indicative value for panels, without additional load)
- Panels are easily installed and fully demountable
- MESH R-L 201 MT Megapanel option (up to 1200 x 1202 mm)

Isometric view

Perimeter solutions on separate datasheet.

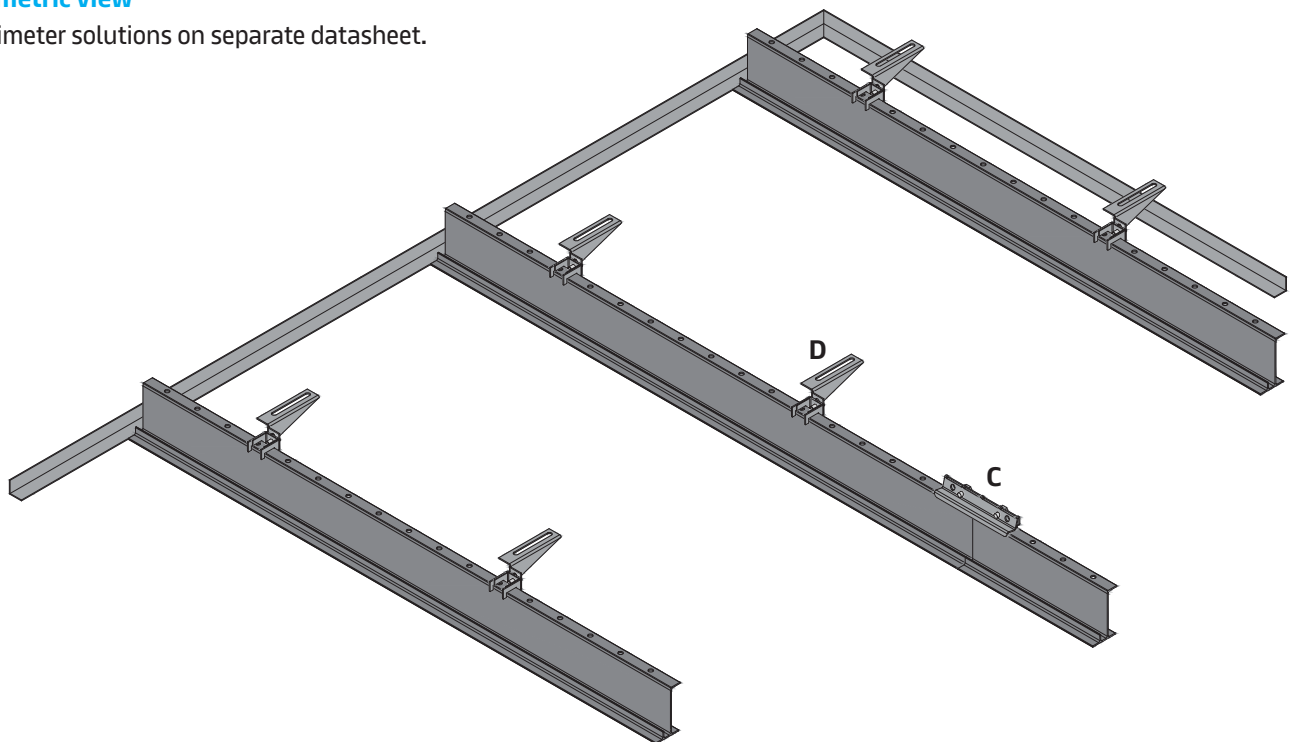

The use of a primary grid system is recommended, as this simplifies levelling and the alignment of the ceiling.

Vario Design & bespoke layout options

Vario Design

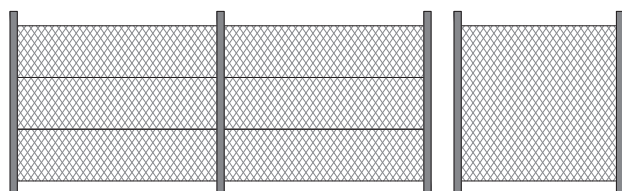

Bespoke (on request)

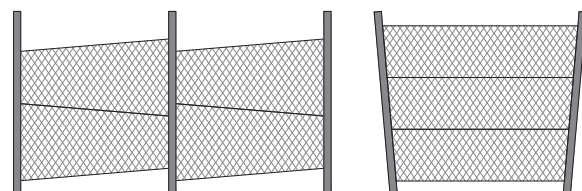

MESH R-L 201 / MESH R-L 201 MT

D03.002.2

Section A (MESH R-L 201)

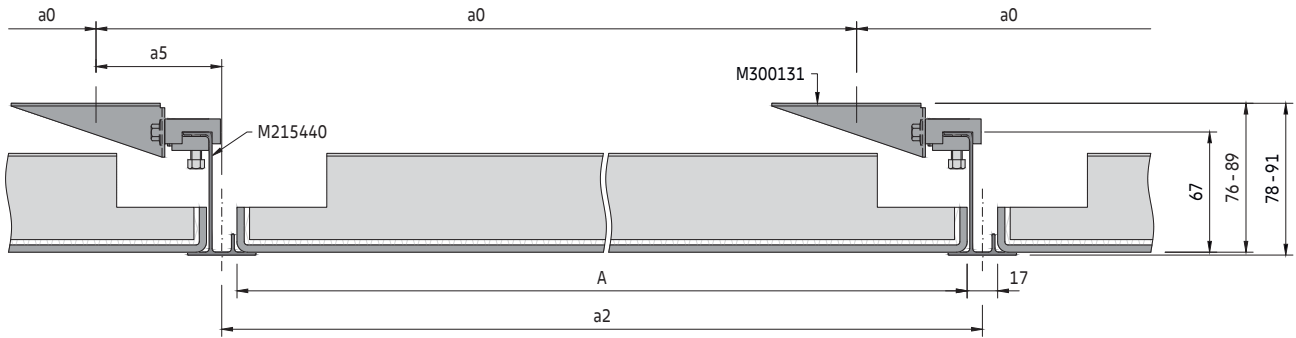

Section A (MESH R-L 201 MT)

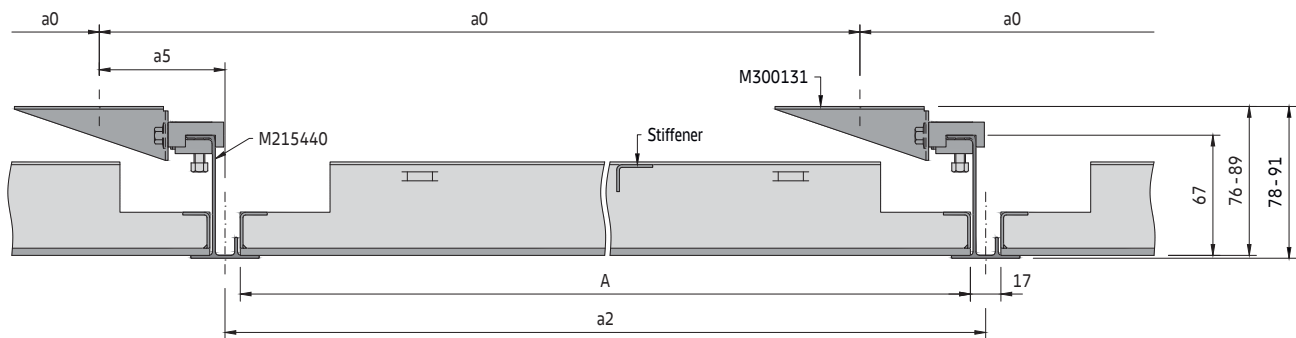

Panels >2000 mm length with additional welded stiffener

Secondary grid components

Standard components:

- M215440 L-Profile RAL 9010
- M300343 Splice connector for L-Profile
- M300131 Direct hanger for L-Profile

L-Profile

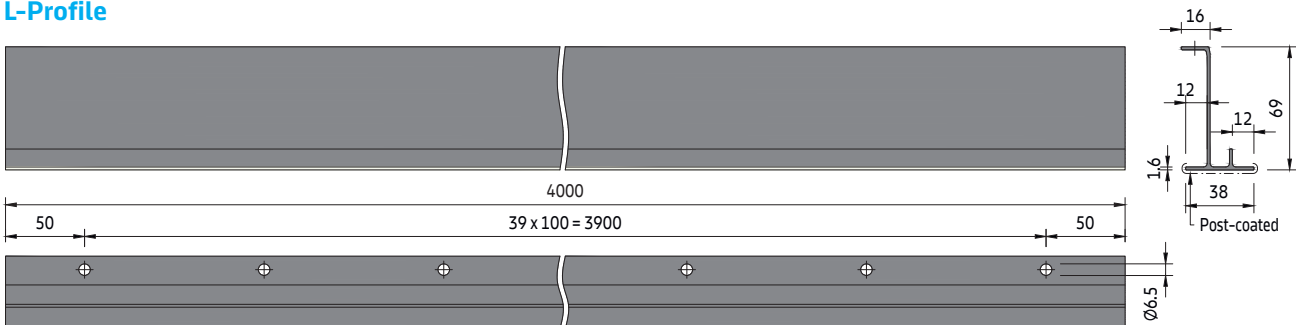

MESH R-L 201 / MESH R-L 201 MT

D03.002.2

Section B (MESH R-L 201)

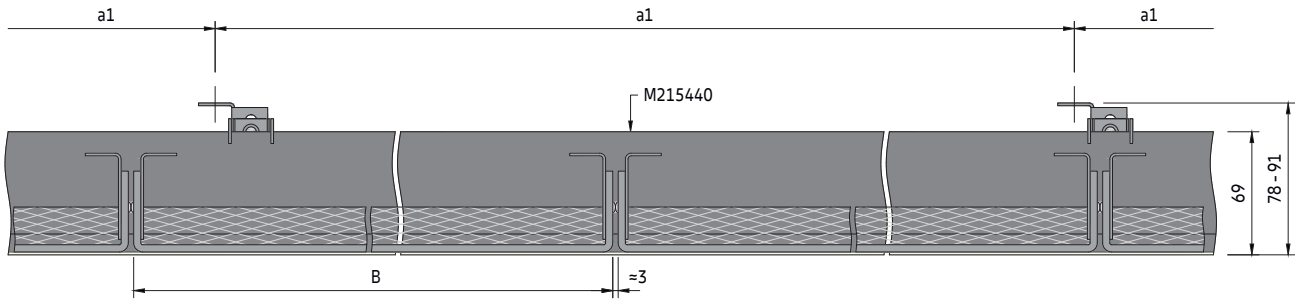

The panels should be installed with a ≈ 3 mm open gap on the long side, which enables installation.

Section B (MESH R-L 201 MT)

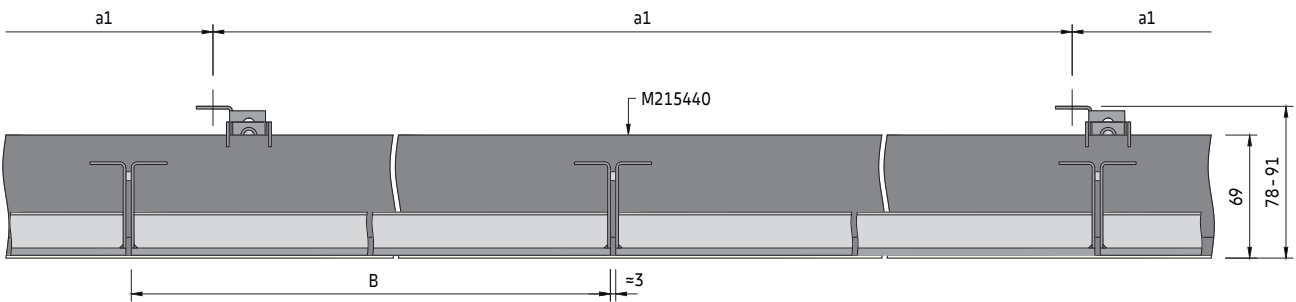

The panels come standard with a ≈ 3 mm spacer on the long side.

MESH R-L 201 / MESH R-L 201 MT
D03.002.2

Spacing

a2 [mm]	System without additional load		System with additional load +4 kg/m²	
	a0 [mm]	a1 [mm]	a0 [mm]	a1 [mm]
600	600	1500	600	1500
650	650	1500	650	1500
700	700	1500	700	1500
750	750	1500	750	1500
800	800	1500	800	1500
850	850	1500	850	1500
900	900	1500	900	1500
950	950	1500	950	1500
1000	1000	1500	1000	1500
1050	1050	1500	1050	1500
1100	1100	1500	1100	1500
1150	1150	1500	1150	1500
1200	1200	1500	1200	1500
1250	1250	1500	1250	1500
1300	1300	1500	1300	1200
1350	1350	1500	1350	1200
1400	1400	1500	1400	1200
1450	1450	1500	1450	1000
1500	1500	1500	1500	1000
1550	1550	1500	1550	1000
1600	1600	1500	1600	800
1650	1650	1200	1650	800
1700	1700	1200	1700	800
1750	1750	1000	1750	600
1800	1800	1000	1800	600
1850	1850	800	1850	600
1900	1900	800	1900	600
1950	1950	800	1950	600
2000	2000	800	2000	600
2050	2050	800	2050	600
2100	2100	800	2100	600
2150	2150	800	2150	600
2200	2200	800	2200	400
2250	2250	800	2250	400
2300	2300	600	2300	400
2350	2350	600	2350	400
2400	2400	600	2400	400
2450	2450	600	2450	400
2500	2500	600	2500	400

Parameters

- a0 Distance between L-Profile suspension points = max. 1900 mm
- a1 Max. distance between direct hangers
- a2 Distance between L-Profiles = panel length + 17 mm
- a3 Distance from wall = max. 200 mm
- a4 Distance from wall = max. panel length
- a5 Distance between L-Profile and top fixing = max. 70 mm
- M Module size = panel length + 17 mm / panel width + ≈3 mm gap
- A Panel length = min. 597 / max. 2500 mm *
- B Panel width = min. 247 / max. 700 mm *

* The dimensions depend on the chosen system and mesh pattern

Typical grid layout

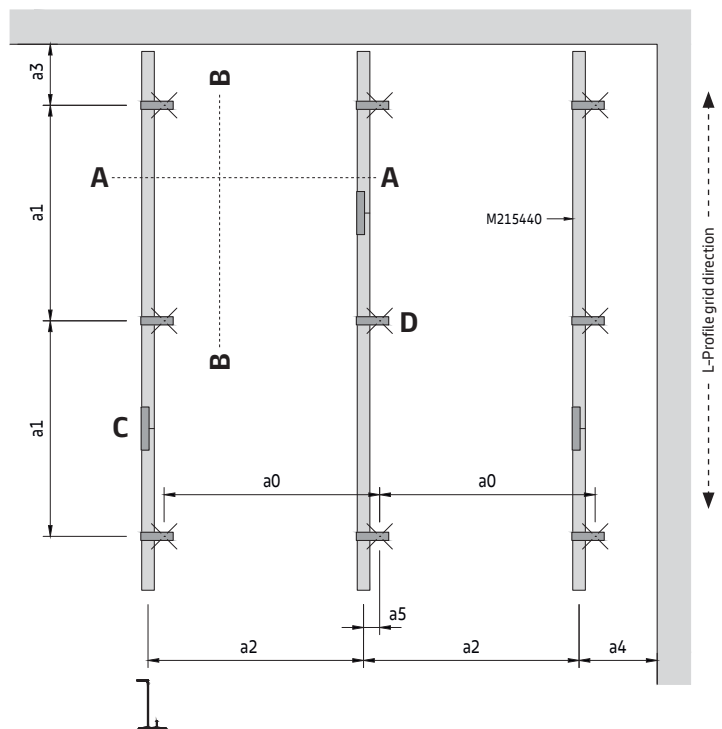

To determine suspension layout

The module length (M) of the requested ceiling is equal to the distance between the L-Profile centres (a2).

On the appropriate spacing table, read down the column headed (a2) to the required module length then read across to determine the suspension point spacing (a0) and direct hanger spacing (a1).

The shown values are maximum allowed distances and can be reduced but not exceeded.

MESH R-L 201 / MESH R-L 201 MT
D03.002.2

Detail C

Splice connection

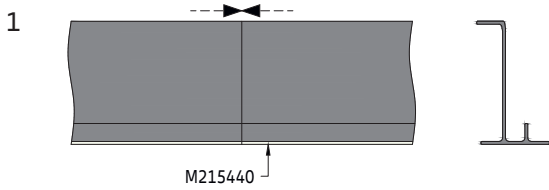

Once the L-Profiles are installed, the ends should be brought together without a gap.

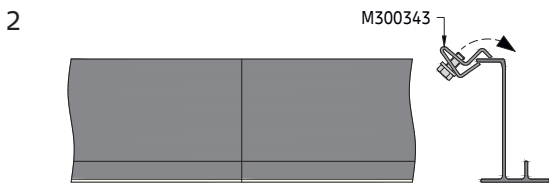

The connectors for the L-Profiles must be inserted from above.

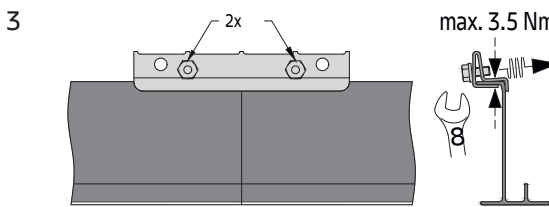

Use the bolts to secure the connector. Stagger the joints.

Detail D

Direct hanger installation

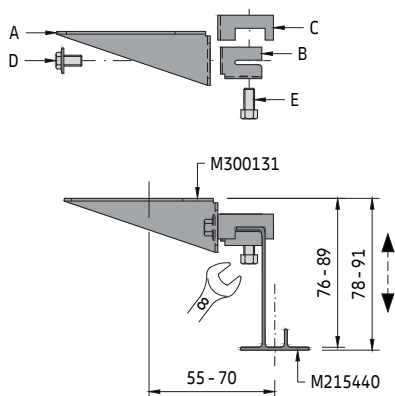

The direct hanger consists of five pre-assembled components (A, B, C, D, E).

Part A is attached to the soffit first. The distance from the L-Profile to the attachment point must not exceed 70 mm.

Part B is not tightened, so the L-Profile can be inserted horizontally. Tightening the bolts (part D, E) creates a stable connection. Before that, the height should be set up and part C inserted from above. Part C is positioned between part A and B and prevents the L-Profile from falling out of the hanger.

Optional Installation

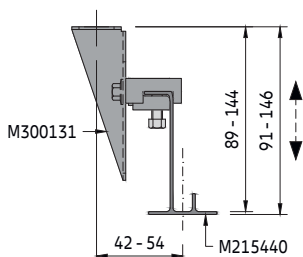

The distance between the L-Profiles should be measured exactly, otherwise the panels are difficult to install and elements could fall out.

The direct hanger can optionally also be installed vertically. To do this, the components must first be disassembled. The shorter side of part A is then attached to the soffit.

MESH R-L 201 / MESH R-L 201 MT
D03.002.2

Detail E

Panel insertion (example with MESH R-L 201)

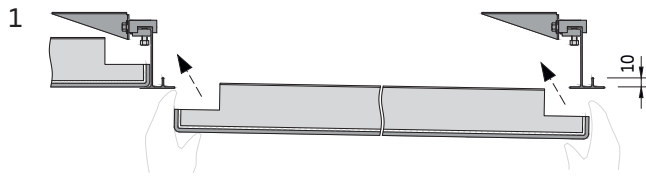

The L-Profile was designed asymmetrically with an additional upstand of 10 mm. As a result, the panels are a little shorter and require less height when installing and extracting.



Insert the panel first on the side where the upstand of the L-Profile is, followed by the opposite side.

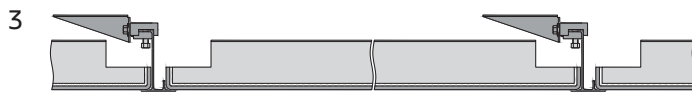

The panel is placed horizontally on the L-Profiles.



Continue with the next panel.

Panel extraction (example with MESH R-L 201)



With a closed ceiling, any panel can be removed as long as there are no obstacles such as service integrations, etc.

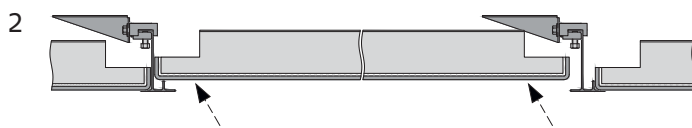

Lift the panel and move it to the direction where the L-Profile upstand is.

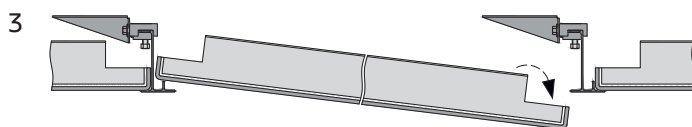

Lower the opposite side.

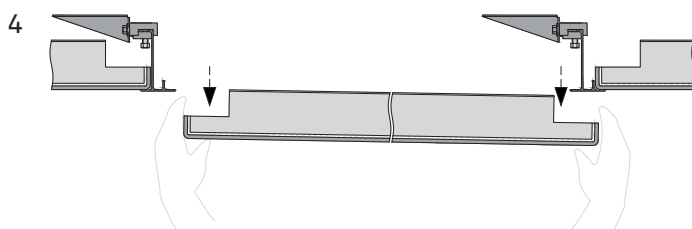

Remove it downwards and store the panel in a safe place so that it cannot be damaged.

MESH R-L 201 / MESH R-L 201 MT
D03.002.2

Installation sequence

Recommended

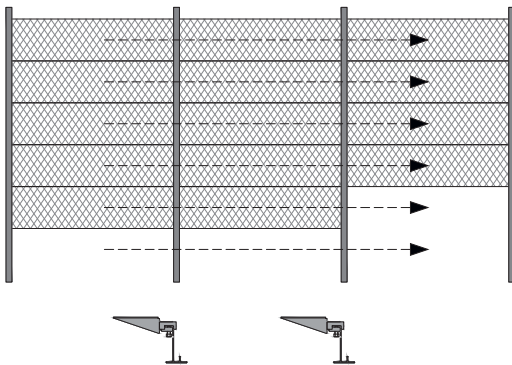

Not recommended

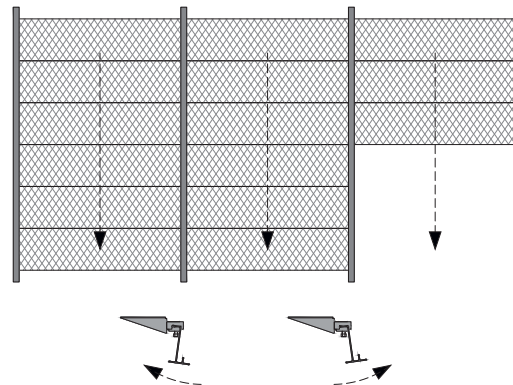

Due to the asymmetric load, the L-Profiles could twist and the panel rows could fall down. Especially with the optional installation, where the direct hanger is installed vertically. This increases leverage.

Material required per m² (no waste included)

System without additional load [pcs/m²]

Components	a2 [mm]	1200	1600	1800	2000	2200	2500
M215440	L-Profile RAL 9010	0.21	0.16	0.14	0.13	0.15	0.10
M300131	Direct hanger for L-Profile	0.56	0.42	0.56	0.63	0.57	0.67
M300343	Splice connector for L-Profile	0.21	0.16	0.14	0.13	0.12	0.10

The shown quantities are theoretical and based on an ideal layout, without considering the actual room layout. The ideal layout is based on a calculation of 10 x 10 m (100 m²). This calculation does not allow any damage, spare nor wastage. The final quantities and type of suspension have to be checked before ordering. Soffit and wall fixings by others. Not including perimeter trims, optional security brackets and extraction tools.



MESH K-H 400
65 Gresham Street, London, United Kingdom © Tom Green

MESH B-L 302 / MESH B-L 302 MT

U-Profile primary grid + Bandraster secondary grid
Exposed linear grid solution for indoor applications

General information

- Exposed lay-in linear grid system for large rooms
- For perpendicular installation on U-Profile primary grid
- Bandraster 100 mm in RAL 9010 made of galvanised steel (colour options on request)
- Typical ceiling weight 8.5 - 10.5 kg/m² (indicative value for panels, without additional load)
- Panels are easily installed and fully demountable
- Tartan grid layout option
- MESH B-L 302 MT Megapanel option (up to 1200 x 1202 mm)

Isometric view

Select the suspension option E1 - E4.
Perimeter solutions on separate datasheet.

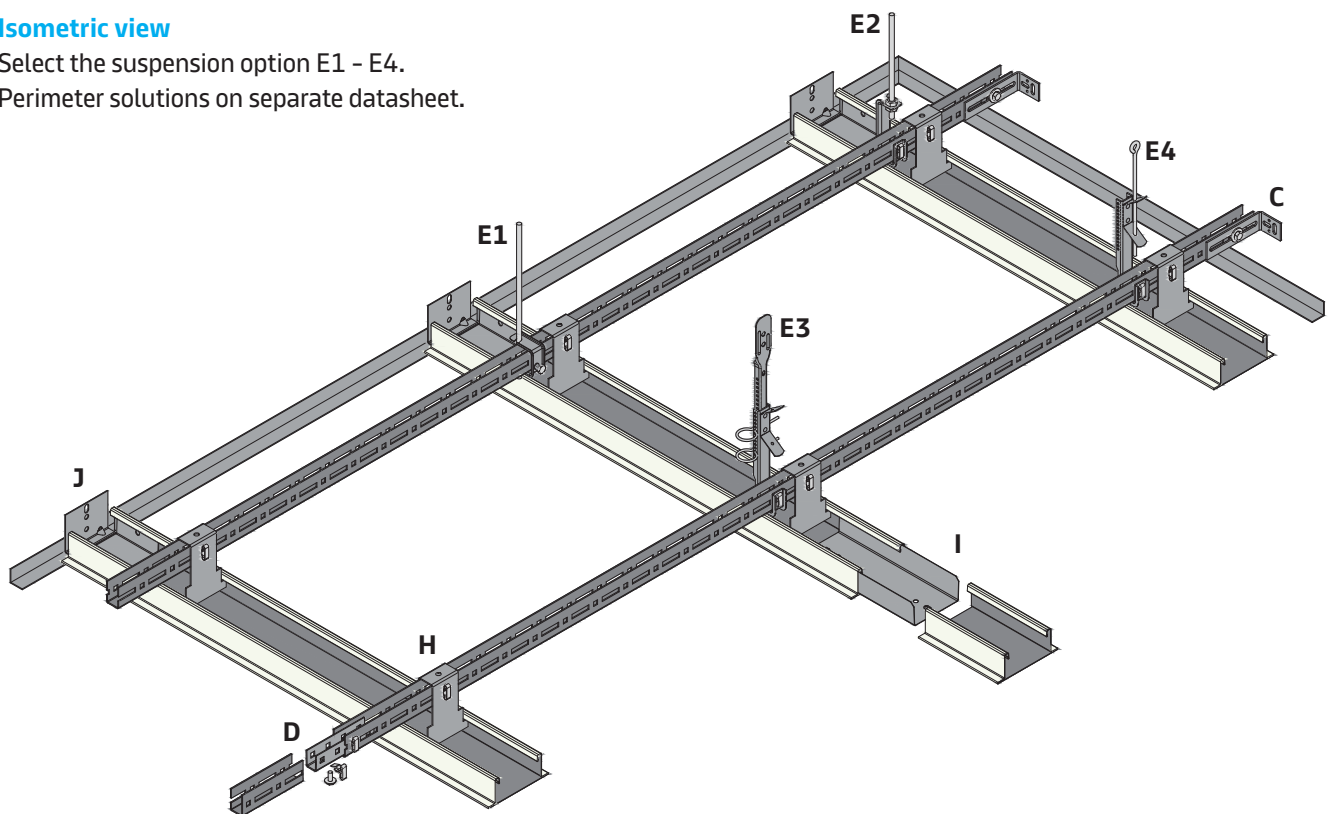

Vario Design & bespoke layout options

Vario Design

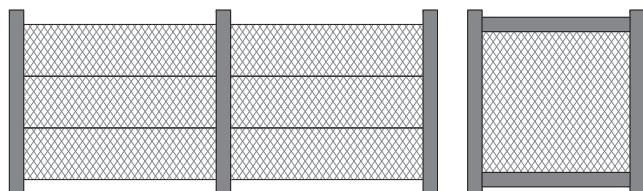

Bespoke (on request)

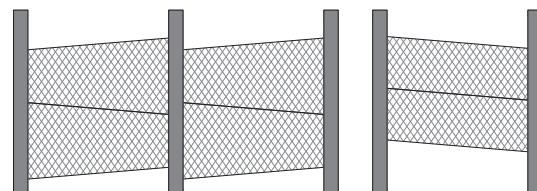

MESH B-L 302 / MESH B-L 302 MT
D03.003

Section F (MESH B-L 302)

Example with suspension option E1

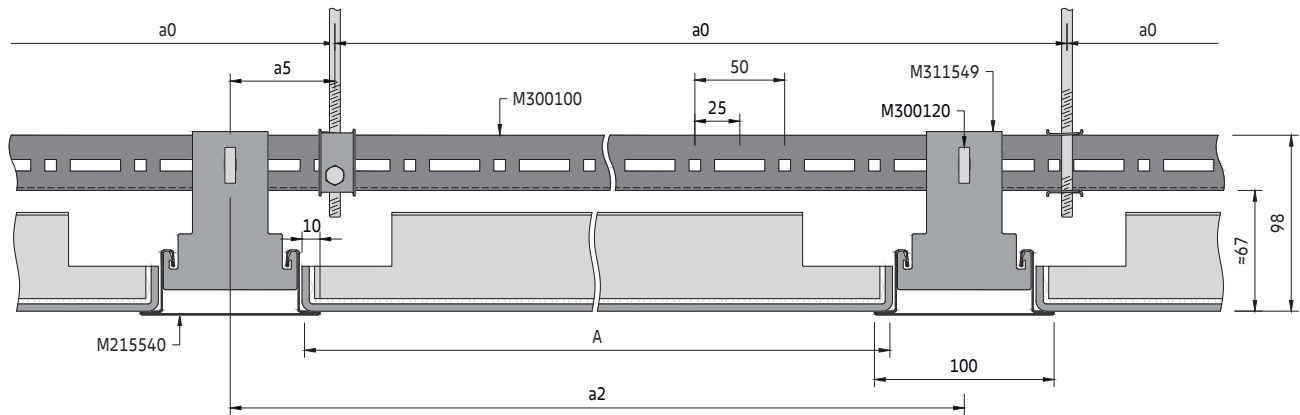

Section F (MESH B-L 302 MT)

Example with suspension option E1

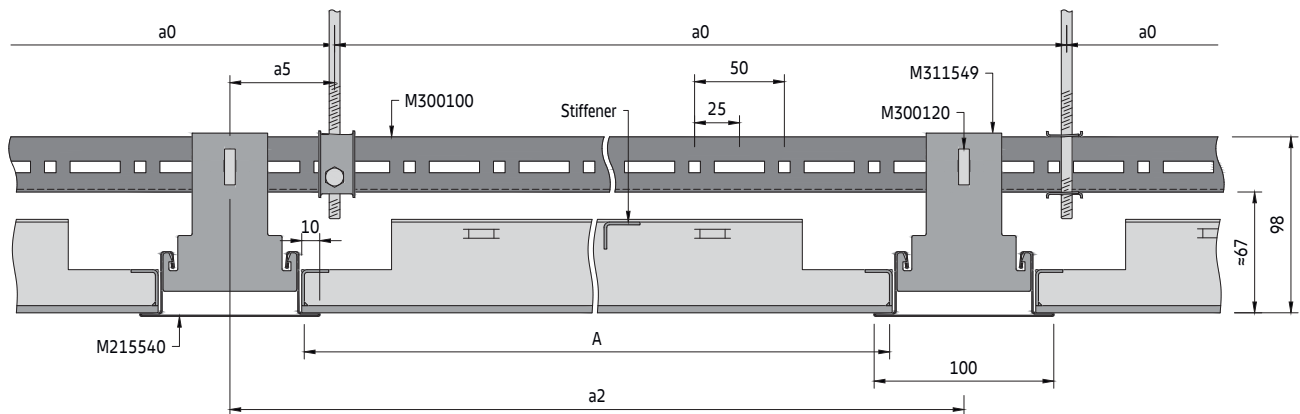

Panels >2000 mm length with additional welded stiffener.

Secondary grid components

Standard components:

- A361005 Wall anchor for Bandraster 100 mm
- M215540 Bandraster 100 mm RAL 9010
- A361003 Splice connector for Bandraster 100 mm
- M300120 Plug-in clip for U-Profile
- M311549 Hanger for Bandraster 100 mm

Standard components:

- A361004 Cross connector for Bandraster 100 mm
- M311191 Self-drilling screw 3.5 x 9.5 mm

See U-Profile primary grid for primary grid components

Bandraster 100 mm secondary grid

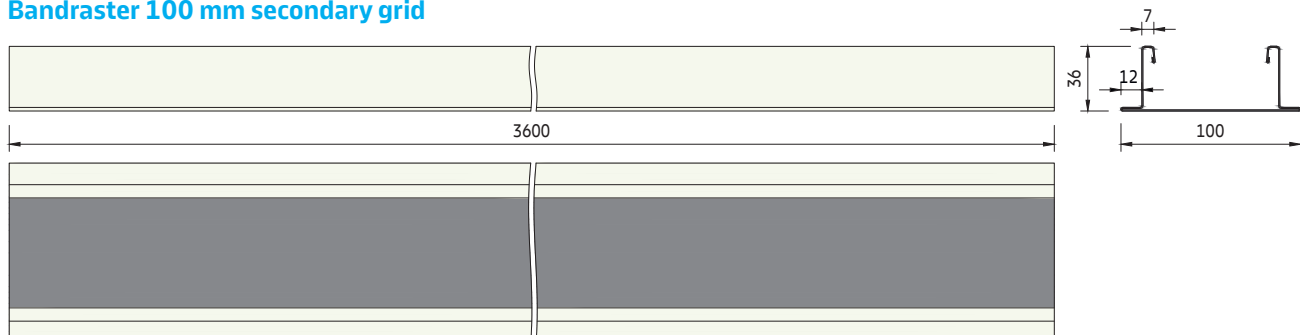

MESH B-L 302 / MESH B-L 302 MT
D03.003

Section G (MESH B-L 302)

Example with suspension option E1

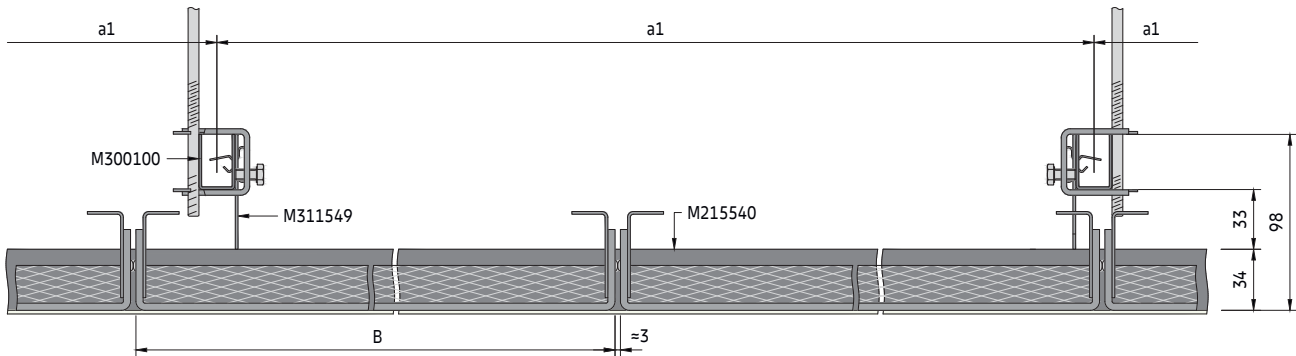

The panels should be installed with a ≈ 3 mm open gap on the long side, which enables installation.

Section G (MESH B-L 302 MT)

Example with suspension option E1

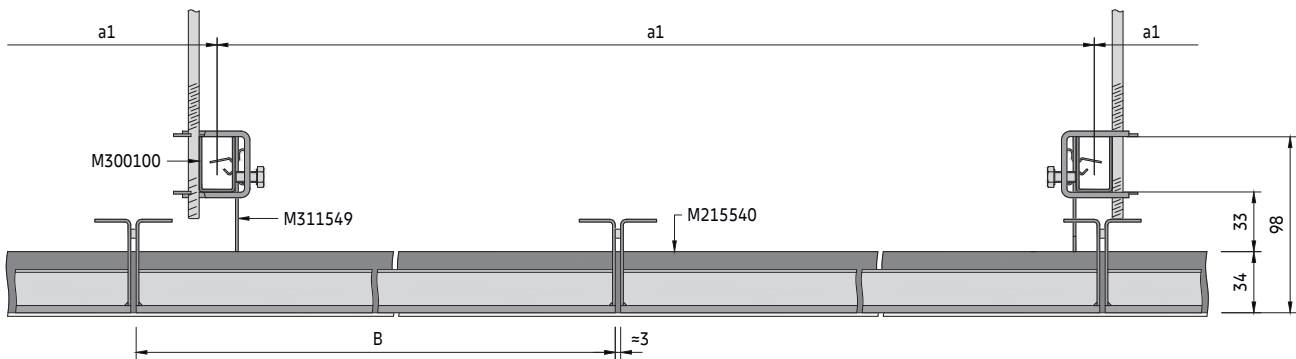

The panels come standard with a ≈ 3 mm spacer on the long side.

Spacing

a2 [mm]	System without additional load		System with additional load +4 kg/m ²	
	a0 [mm]	a1 [mm]	a0 [mm]	a1 [mm]
600	1200	1900	1200	1550
650	1300	1850	1300	1300
700	1400	1550	1400	1100
750	1500	1350	750	1600
800	1600	1150	800	1550
850	850	1650	850	1500
900	900	1600	900	1450
950	950	1550	950	1400
1000	1000	1500	1000	1400
1050	1050	1450	1050	1350
1100	1100	1450	1100	1300
1150	1150	1400	1150	1300
1200	1200	1400	1200	1250
1250	1250	1350	1250	1250
1300	1300	1300	1300	1200
1350	1350	1300	1350	1150
1400	1400	1250	1400	1100
1450	1450	1250	1450	1000
1500	1500	1250	1500	950
1550	1550	1200	1550	850
1600	1600	1150	1600	800
1650	1650	1100	1650	750
1700	1700	1000	1700	700
1750	1750	900	875	1050
1800	1800	800	900	1050
1850	925	1100	925	1000
1900	950	1100	950	1000
1950	975	1100	975	1000
2000	1000	1050	1000	1000
2050	1025	1050	1025	950
2100	1050	1050	1050	950
2150	1075	1050	1075	950
2200	1100	1000	1100	950
2250	1125	1000	1125	900
2300	1150	1000	1150	900
2350	1175	1000	1175	900
2400	1200	950	1200	900
2450	1225	950	1225	900
2500	1250	950	1250	850

Parameters

- a0 Distance between U-Profile suspension points = max. 1900 mm
- a1 Max. distance between U-Profiles
- a2 Distance between Bandraster 100 mm
- a3 Distance from wall = max. 200 mm
- a4 Distance from wall = max. panel length
- a5 Distance from U-Profile suspension point to hanger = max. 100 mm
- M Module size = Bandraster width + panel length - 20 mm / panel width + ≈3 mm gap
- A Panel length = min. 595 / max. 2500 mm *
- B Panel width = min. 247 / max. 700 mm *

* The dimensions depend on the chosen system and mesh pattern

Typical grid layout

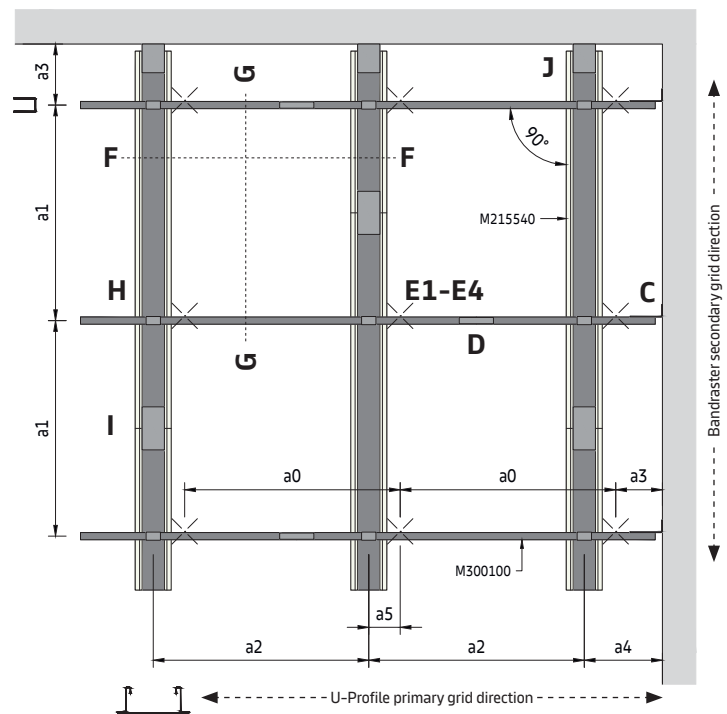

To determine suspension layout

The module length (M) of the requested ceiling is equal to the distance between the Bandraster centres (a2).

On the appropriate spacing table, read down the column headed (a2) to the required module length then read across to determine the suspension point spacing (a0) and U-Profile spacing (a1).

The shown values are maximum allowed distances and can be reduced but not exceeded.

MESH B-L 302 / MESH B-L 302 MT
D03.003

Detail H

Hanger installation

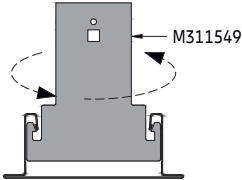
- 1  Twist the hanger into the Bandraster from above.

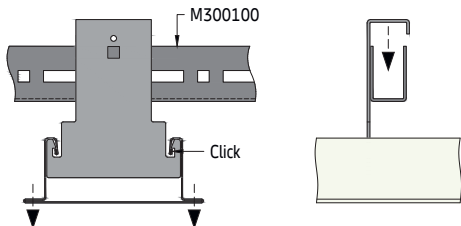
- 2  Hook the Bandraster with the hangers on the U-Profile and pull the Bandraster carefully down until it snaps in (click).

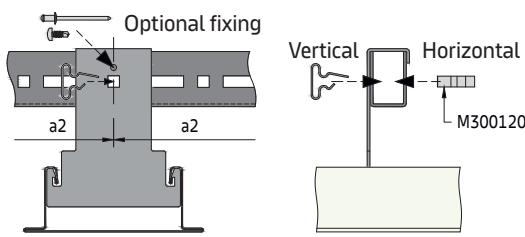
- 3  Fix hanger with plug-in clips at the specified module spacing (inserted vertically or horizontally). If the panel size does not fit with the modulation of the U-Profile (25 mm increments), the plug-in clip needs to be inserted into a long hole. The hanger position can alternatively be fixed by using a pop-rivet or self-drilling screw.

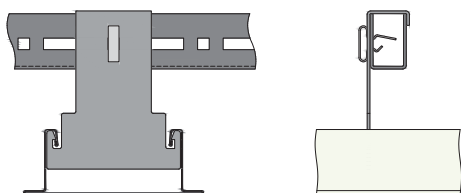
- 4  The Bandraster is now locked in position.

Detail I

Splice connection

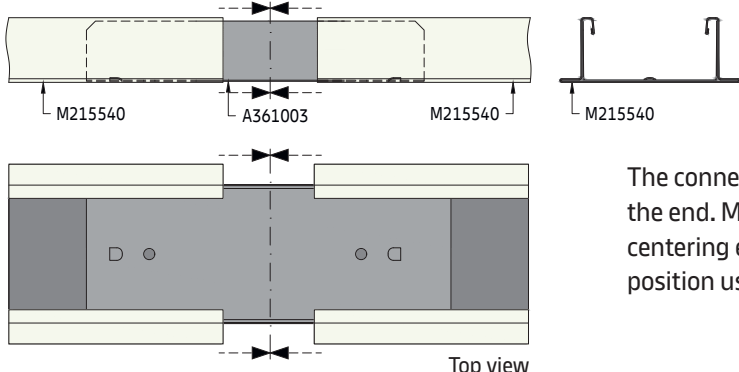
- 1  The connectors for the Bandraster must be inserted from the end. Make sure the connector is centered. To make centering easier, you can use a screwdriver to adjust the position using the small tabs on the back of the connector.

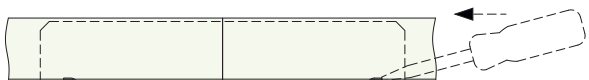
- 2  The ends of the Bandraster should be brought together without a gap. Stagger the joints.

MESH B-L 302 / MESH B-L 302 MT
D03.003

Detail J

Wall anchor installation

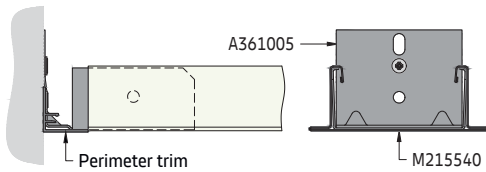

The wall anchor prevents the Bandraaster from swinging and thus contributes to the safe installation of the substructure. The wall anchor has no load-bearing function and is only attached to one end of the room to secure the Bandraaster.

Detail K

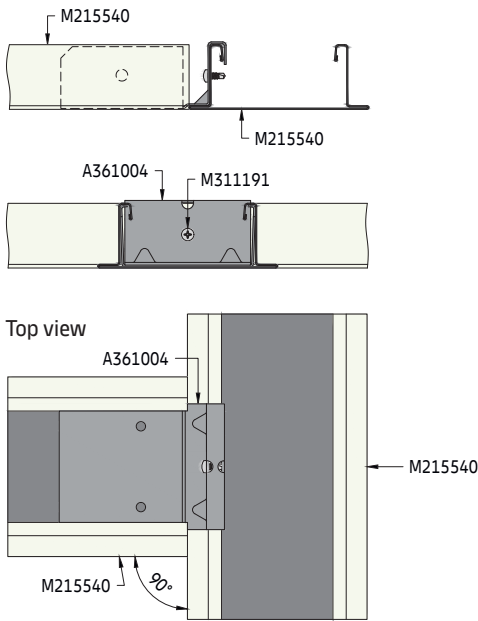

Cross-connector installation for tartan grid layout option

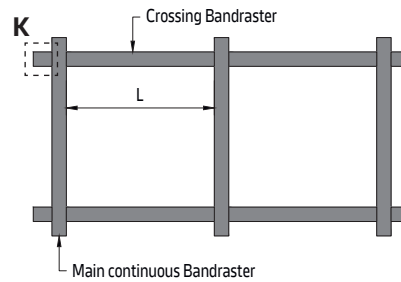

With the cross-connector, a tartan grid layout can be simulated without using crossing-boxes. Bandraaster cut to length are installed across the continuous Bandraaster. Crossing Bandraaster (L) = module length - Bandraaster width 100 mm

Material required per m² (no waste included)

System without additional load [pcs/m²]

Components	a2 [mm]	1200	1600	1800	2000	2200	2500
A361003	Splice connector for Bandraaster 100 mm	0.24	0.18	0.16	0.14	0.13	0.12
A361005	Wall anchor for Bandraaster 100 mm	0.18	0.14	0.12	0.12	0.11	0.10
M215540	Bandraaster 100 mm RAL 9010	0.23	0.18	0.16	0.14	0.13	0.11
M300100	U-Profile	0.19	0.23	0.33	0.25	0.27	0.28
M300119	Splice connector for U-Profile	0.20	0.24	0.34	0.26	0.27	0.29
M300120	Plug-in clip for U-Profile	1.00	1.03	1.38	1.00	1.00	1.01
M300140	Wall anchor	0.08	0.09	0.13	0.10	0.11	0.11
M311103	Hexagonal nut M6	0.10	0.10	0.10	0.10	0.10	0.10
M311105	Washer	0.10	0.10	0.10	0.10	0.10	0.10
M311303	Hexagonal bolt M6 x 16 mm	0.10	0.10	0.10	0.10	0.10	0.10
M311549	Hanger for Bandraaster 100 mm	0.60	0.55	0.70	0.48	0.46	0.43
Various	Suspension points (E1 - E4)	0.60	0.55	0.70	0.96	0.91	0.85

The shown quantities are theoretical and based on an ideal layout, without considering the actual room layout. The ideal layout is based on a calculation of 10 x 10 m (100 m²). This calculation does not allow any damage, spare nor wastage. The final quantities and type of suspension have to be checked before ordering. Soffit and wall fixings by others. Not including perimeter trims, optional security brackets and extraction tools.

Detail L

Panel insertion (example with MESH B-L 302)

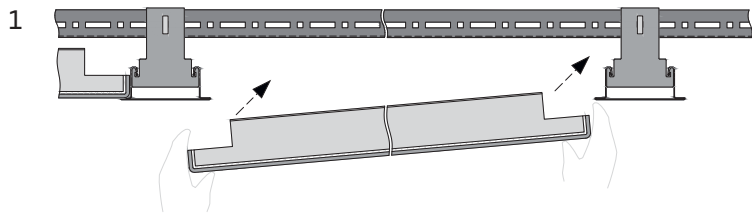

1 Insert the panel at a slight angle, above the Bandraster.

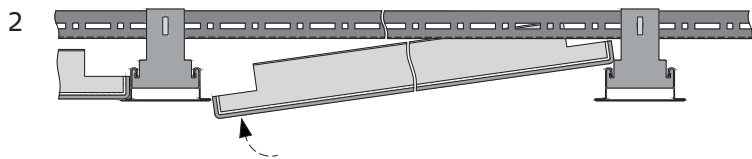

2 Lift up the opposite end of the panel above the leg of the Bandraster.

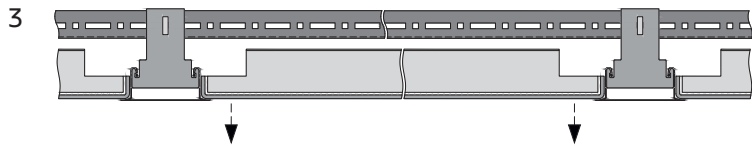

3 Rest the panel on the Bandraster.

Panel extraction (example with MESH B-L 302)

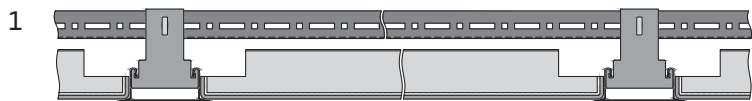

1 With a closed ceiling, any panel can be removed as long as there are no obstacles such as service integrations, etc.

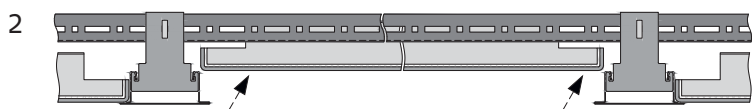

2 Lift the panel above the Bandraster.

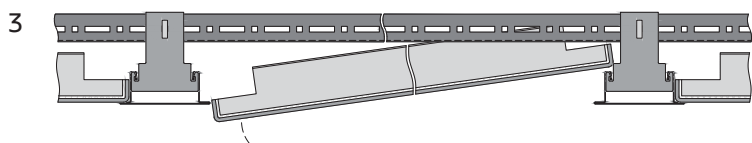

3 Lower the opposite side.

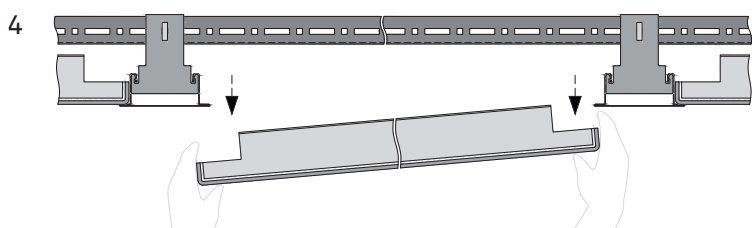

4 Remove it downwards and store the panel in a safe place so that it cannot be damaged.



MESH B-L 302

HSBC Headquarters, Birmingham, United Kingdom © Jack Hobhouse

MESH B-H 300 / MESH B-H 300 MT

U-Profile primary grid + C-Profile secondary grid
Exposed linear grid solution for indoor applications

General information

- Exposed hook-on linear grid system for large rooms
- For perpendicular installation on U-Profile primary grid
- C-Profile 100 mm in RAL 9010 made of galvanised steel (further sizes, cut-outs and colour options on request)
- Typical ceiling weight 9.0 - 10.5 kg/m² (indicative value for panels, without additional load)
- Panels are easily installed and fully demountable
- Hinge-down option
- Tartan grid layout option
- Long side suspended option
- MESH B-H 300 MT Megapanel option (up to 1200 x 1202 mm)

Isometric view

Select the suspension option E1 - E4.
Perimeter solutions on separate datasheet.

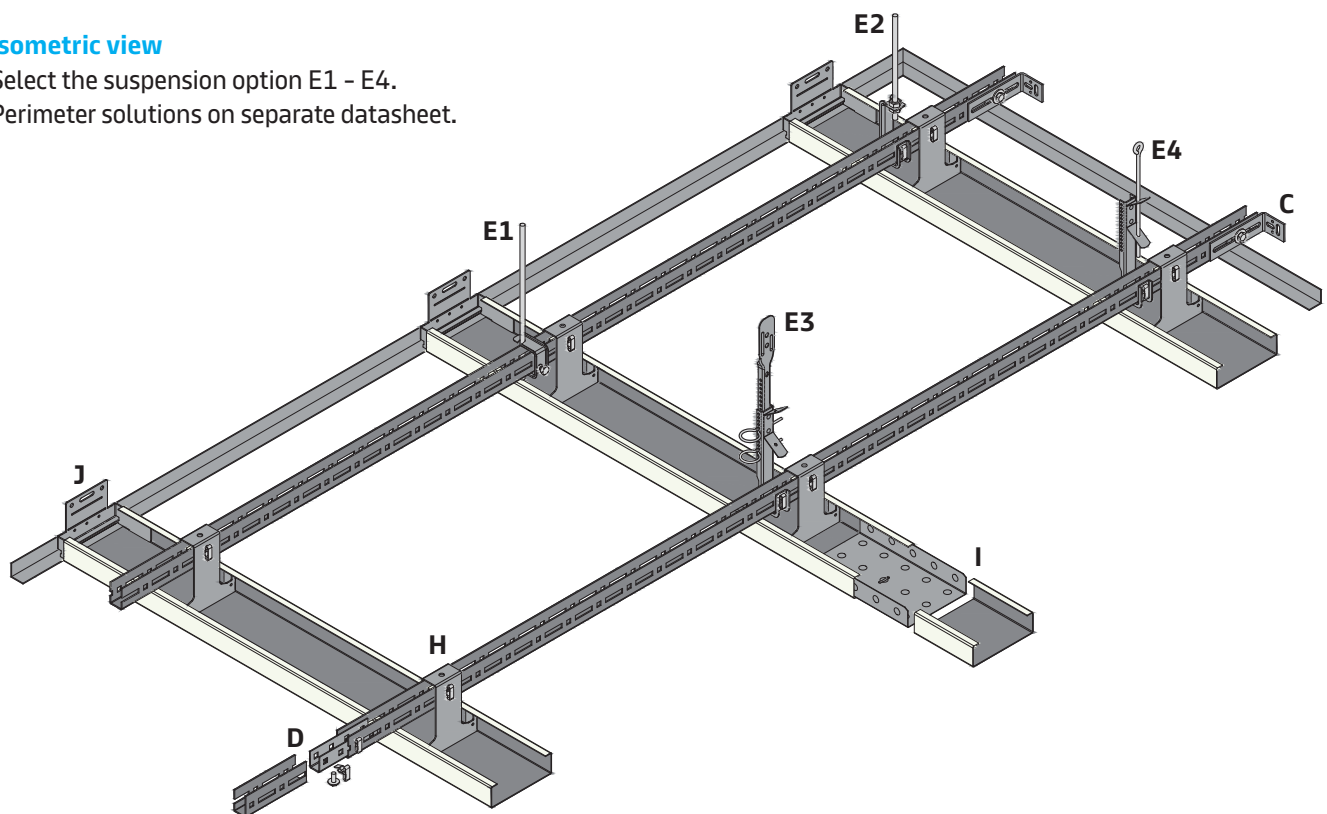

Vario Design & bespoke layout options

Vario Design

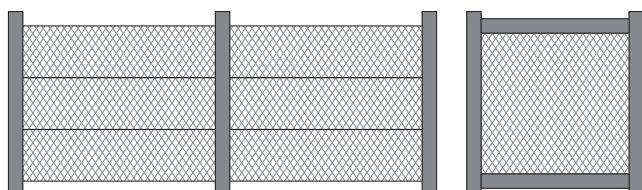

Bespoke (on request)

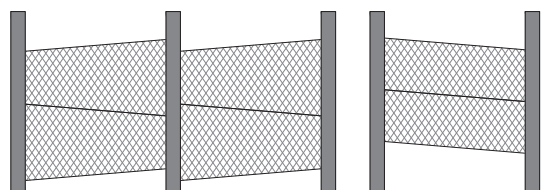

MESH B-H 300 / MESH B-H 300 MT
D03.004

Section F (MESH B-H 300)

Example with suspension option E1

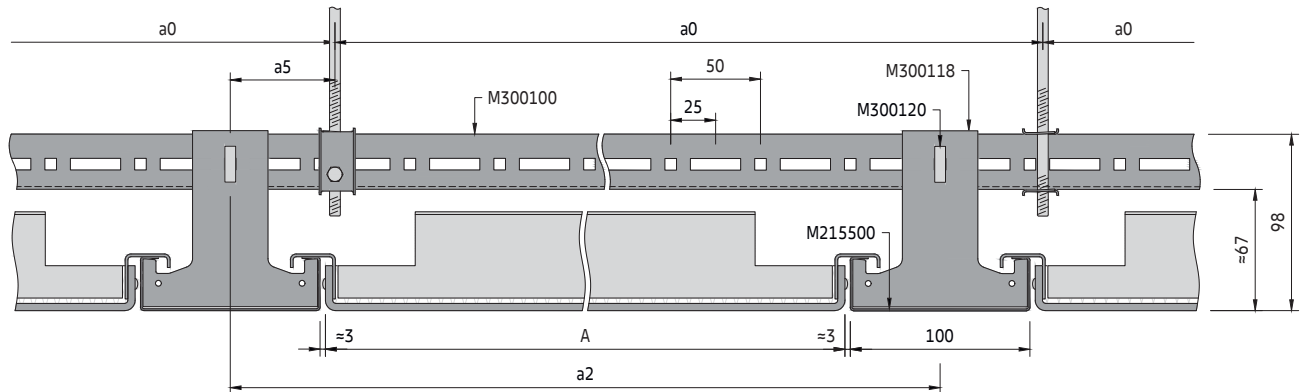

The panels should be installed with a ≈ 3 mm open gap on the short sides, which enables installation.

Section F (MESH B-H 300 MT)

Example with suspension option E1

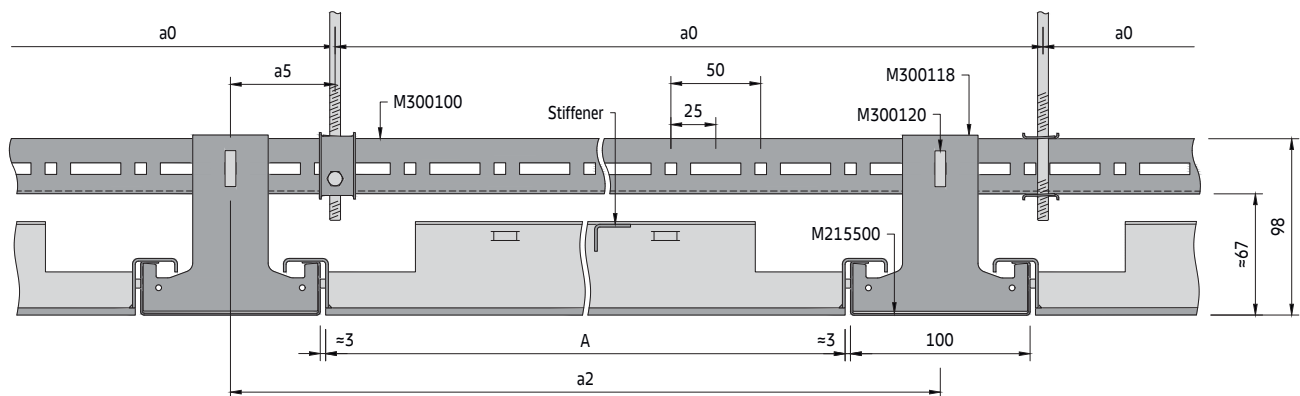

The panels come standard with a ≈ 3 mm spacer on the short sides. Panels >2000 mm length with additional welded stiffener.

Secondary grid components

Standard components:

- M215500 C-Profile 100 mm RAL 9010
- M300118 Hanger for C-Profile 100 mm
- M300120 Plug-in clip for U-Profile
- M300144 Wall anchor for C-Profile 100 mm
- M311067 Splice connector for C-Profile 100 mm

Optional components

- M311191 Self-drilling screw 3.5 x 9.5 mm

See U-Profile primary grid for primary grid components

C-Profile 100 mm secondary grid

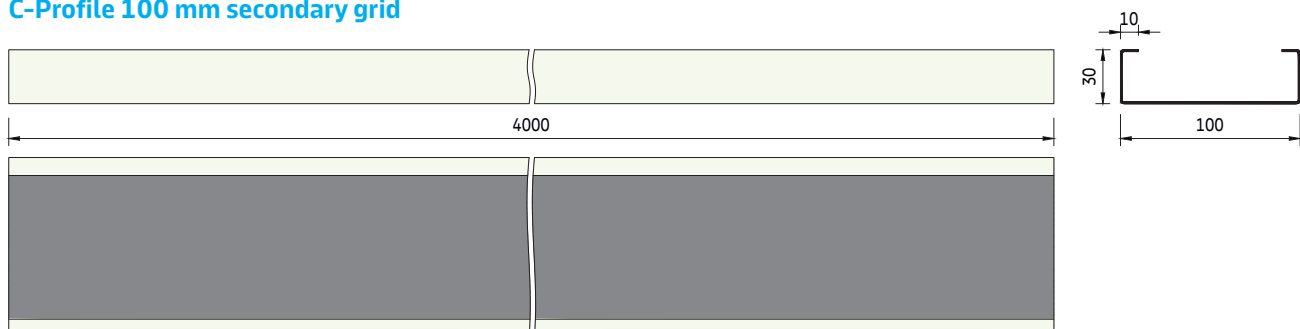

MESH B-H 300 / MESH B-H 300 MT
D03.004

Section G (MESH B-H 300)

Example with suspension option E1

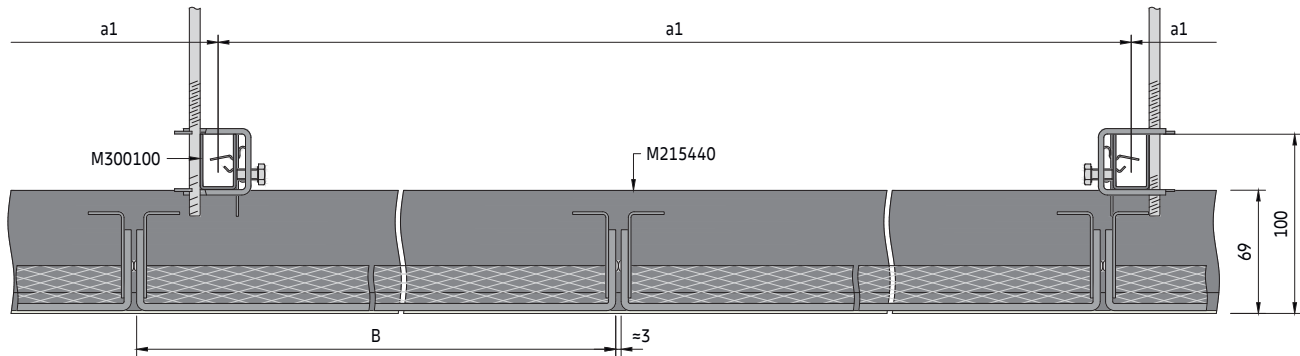

The panels should be installed with a ≈ 3 mm open gap on the long side, which enables installation.

Section G (MESH B-H 300 MT)

Example with suspension option E1

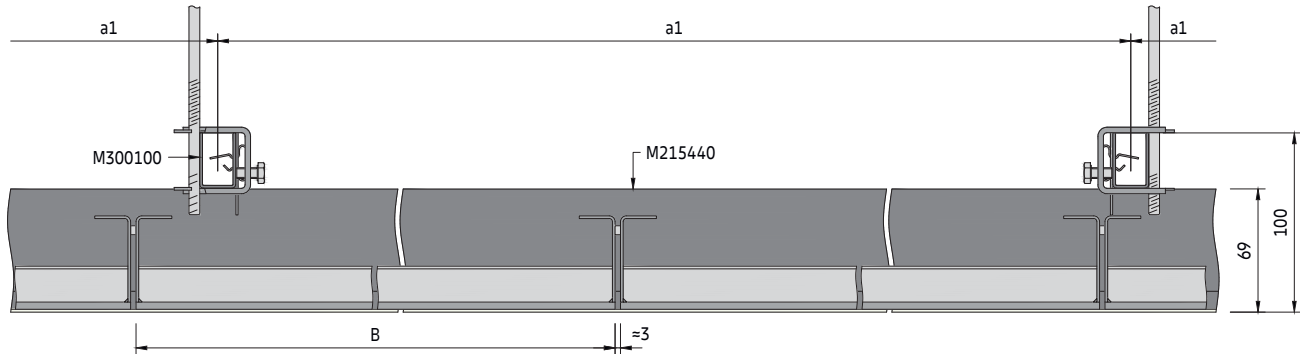

The panels come standard with a ≈ 3 mm spacer on the long side.

Material required per m² (no waste included)

System without additional load [pcs/m²]

Components	a2 [mm]	1200	1600	1800	2000	2200	2500
M215500	C-Profile 100 mm RAL 9010	0.21	0.16	0.14	0.13	0.12	0.10
M300100	U-Profile	0.18	0.25	0.35	0.22	0.23	0.25
M300118	Hanger for C-Profile 100 mm	0.56	0.60	0.75	0.42	0.40	0.39
M300119	Splice connector for U-Profile	0.18	0.26	0.36	0.23	0.24	0.26
M300120	Plug-in clip for U-Profile	0.92	1.12	1.47	0.88	0.88	0.91
M300140	Wall anchor	0.07	0.10	0.14	0.09	0.09	0.10
M300144	Wall anchor for C-Profile 100 mm	0.18	0.14	0.12	0.12	0.10	0.10
M311067	Splice connector for C-Profile 100 mm	0.21	0.16	0.14	0.13	0.12	0.10
M311103	Hexagonal nut M6	0.10	0.10	0.10	0.10	0.10	0.10
M311105	Washer	0.10	0.10	0.10	0.10	0.10	0.10
M311303	Hexagonal bolt M6 x 16 mm	0.10	0.10	0.10	0.10	0.10	0.10
Various	Suspension points (E1 - E4)	0.56	0.60	0.75	0.84	0.80	0.77

The shown quantities are theoretical and based on an ideal layout, without considering the actual room layout. The ideal layout is based on a calculation of 10 x 10 m (100 m²). This calculation does not allow any damage, spare nor wastage. The final quantities and type of suspension have to be checked before ordering. Soffit and wall fixings by others. Not including perimeter trims, optional security brackets and extraction tools.

MESH B-H 300 / MESH B-H 300 MT

D03.004

Spacing

a2 [mm]	System without additional load		System with additional load +4 kg/m²	
	a0 [mm]	a1 [mm]	a0 [mm]	a1 [mm]
600	1200	1700	1200	1250
650	1300	1450	1300	1100
700	1400	1250	700	1800
750	1500	1100	750	1750
800	800	1800	800	1700
850	850	1750	850	1650
900	900	1700	900	1600
950	950	1700	950	1550
1000	1000	1650	1000	1500
1050	1050	1600	1050	1500
1100	1100	1550	1100	1450
1150	1150	1550	1150	1400
1200	1200	1500	1200	1350
1250	1250	1500	1250	1250
1300	1300	1500	1300	1150
1350	1350	1450	1350	1050
1400	1400	1350	1400	1000
1450	1450	1250	1450	900
1500	1500	1200	1500	850
1550	1550	1100	1550	800
1600	1600	1050	1600	750
1650	1650	950	1650	700
1700	1700	900	1700	650
1750	1750	800	1750	600
1800	1800	750	900	1150
1850	1850	650	925	1150
1900	950	1200	950	1100
1950	975	1200	975	1100
2000	1000	1200	1000	1100
2050	1025	1150	1025	1100
2100	1050	1150	1050	1050
2150	1075	1150	1075	1050
2200	1100	1150	1100	1050
2250	1125	1100	1125	1050
2300	1150	1100	1150	1000
2350	1175	1100	1175	1000
2400	1200	1100	1200	1000
2450	1225	1050	1225	1000
2500	1250	1050	1250	1000

Parameters

- a0 Distance between U-Profile suspension points = max. 1900 mm
- a1 Max. distance between U-Profiles
- a2 Distance between C-Profile 100 mm
- a3 Distance from wall = max. 200 mm
- a4 Distance from wall = max. panel length
- a5 Distance from U-Profile suspension point to hanger = max. 100 mm
- M Module size = C-Profile width + panel length + 2x ≈3 mm gap / panel width + ≈3 mm gap
- A Panel length = min. 597 / max. 2500 mm *
- B Panel width = min. 247 / max. 700 mm *

* The dimensions depend on the chosen system and mesh pattern

Typical grid layout

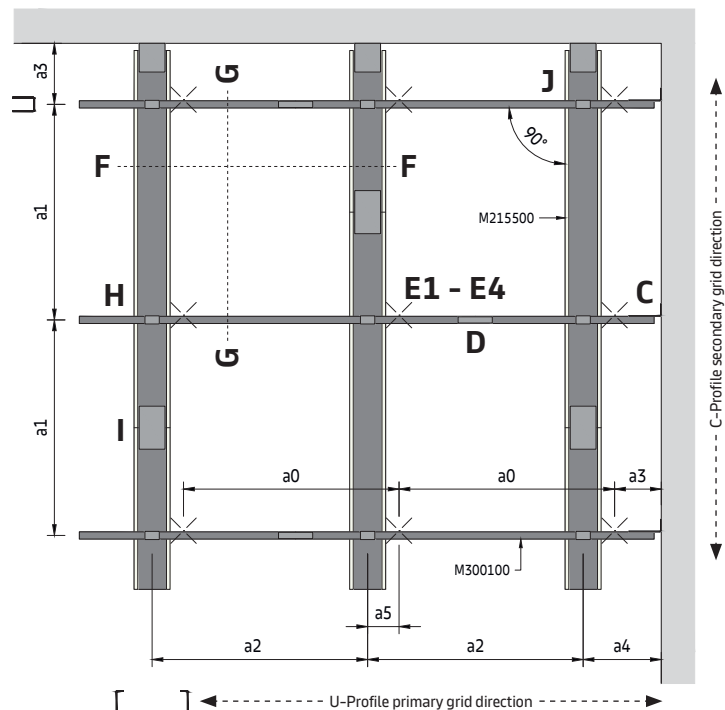

To determine suspension layout

The module length (M) of the requested ceiling is equal to the distance between the C-Profile centres (a2).

On the appropriate spacing table, read down the column headed (a2) to the required module length then read across to determine the suspension point spacing (a0) and U-Profile spacing (a1).

The shown values are maximum allowed distances and can be reduced but not exceeded.

MESH B-H 300 / MESH B-H 300 MT
D03.004

Detail H

Hanger installation

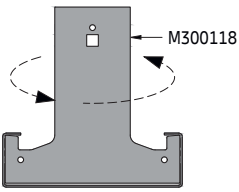
- 1  Twist the hanger on the C-Profile from above.

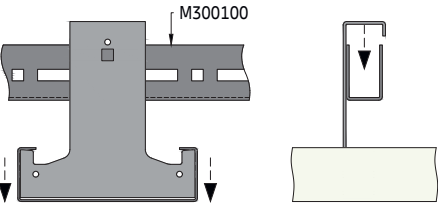
- 2  Hook the C-Profile with the hangers on the U-Profile.

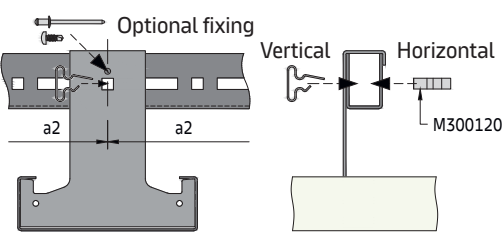
- 3  Fix hanger with plug-in clips at the specified module spacing (inserted vertically or horizontally). If the panel size does not fit with the modulation of the U-Profile (25 mm increments), the plug-in clip needs to be inserted into a long hole. The hanger position can alternatively be fixed by using a pop-riquet or self-drilling screw.

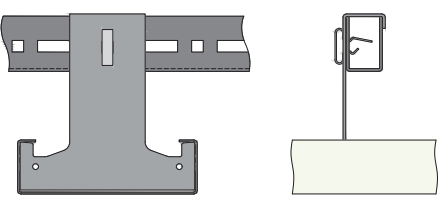
- 4  The C-Profile is now locked in position.

Detail I

Splice connection

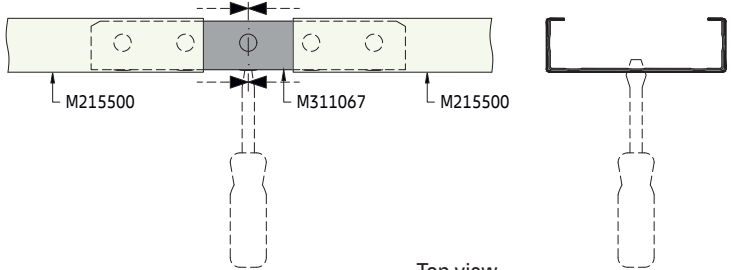
- 1  The connectors for the C-Profile must be inserted from the end. Make sure the connector is centered. To make centering easier you can use a screwdriver to adjust the position using the slot in the connector.

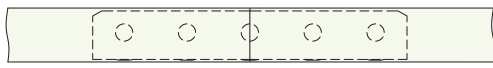
- 2  The ends of the C-Profiles should be brought together without a gap. Stagger the joints.

MESH B-H 300 / MESH B-H 300 MT
D03.004

Detail J

Wall anchor installation

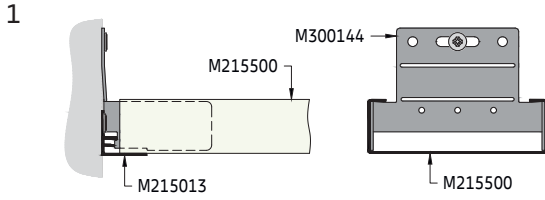

The wall anchor prevents the C-Profile from swinging and thus contributes to the safe installation of the substructure. The wall anchor has no load-bearing function and is only attached to one end of the room to secure the C-Profile.

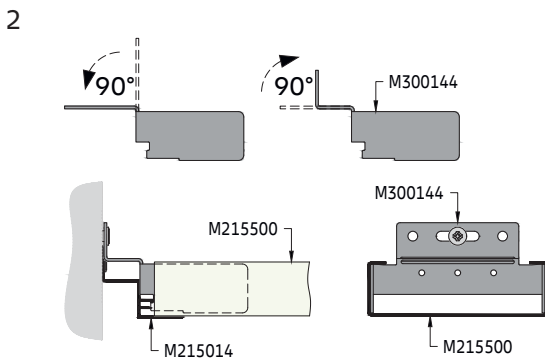

When using a shadowline perimeter trim, the upper part must first be bent 90° down and then 90° up again, so that a step is created.

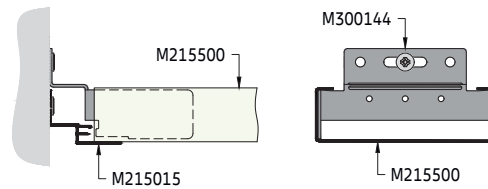

Detail K

Cross-connector installation for tartan grid layout option

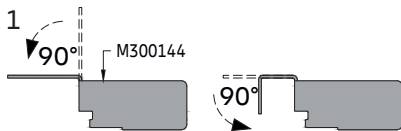

With the cross-connector, a tartan grid layout can be simulated without using crossing-boxes. Bend the upper part of the hanger twice by 90° until a hook is formed.

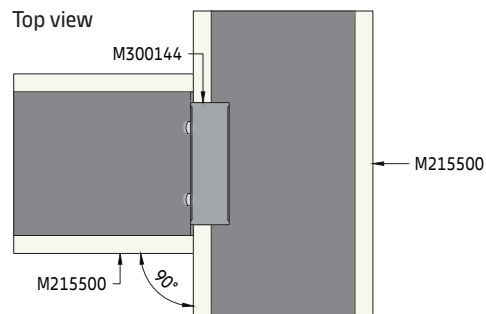
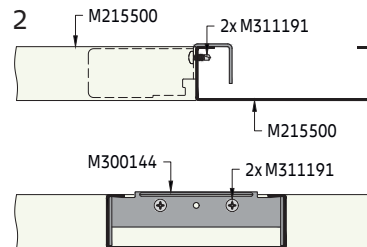
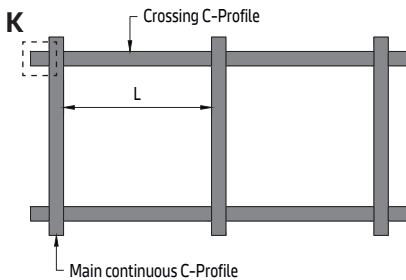

Use two self-drilling screws to attach the hanger to the C-Profile. C-Profiles cut to length are installed across the continuous C-Profiles.

Crossing C-Profile (L) = module length - C-Profile width

Detail L

Panel insertion (example with MESH B-H 300)

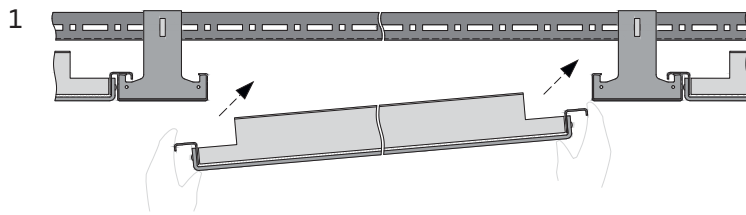

Insert the panel at a slight angle, above the C-Profile.

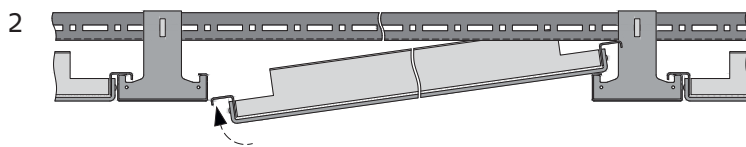

Lift up the opposite end of the panel above the opposite C-Profile.

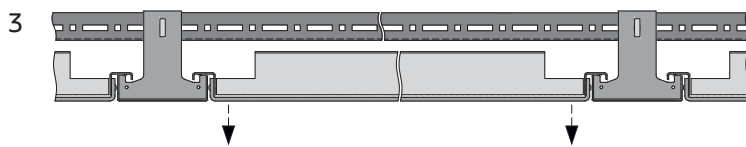

Rest the panel on the C-Profiles.

Panel extraction (example with MESH B-H 300)

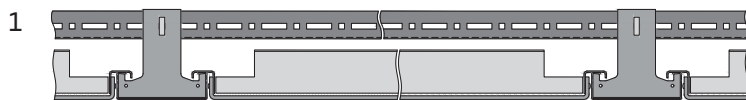

With a closed ceiling, any panel can be removed as long as there are no obstacles such as service integrations, etc.

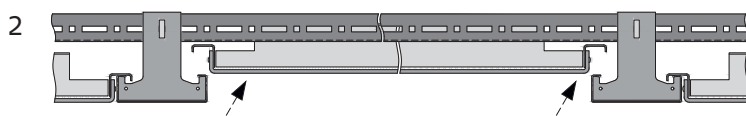

Lift the panel above the C-Profile.

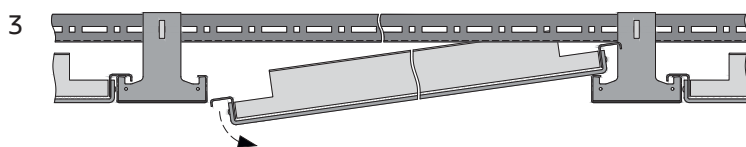

Lower the opposite side.

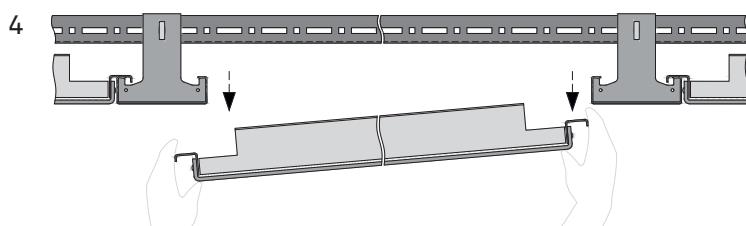

Remove it downwards and store the panel in a safe place so that it cannot be damaged.

MESH B-H 300 / MESH B-H 300 MT

D03.004

Detail M

Hinge-down option (example with MESH B-H 300 EASY)

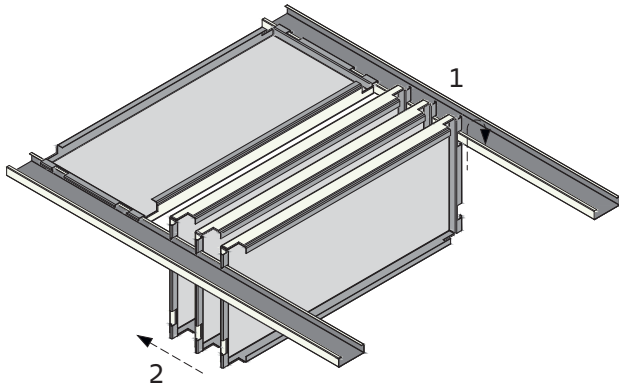

- 1 Extract the panel as shown under Detail L and hang it back vertically on the C-Profile. The panels hinge-down from the long side.
- 2 Move the panel aside to allow access to the plenum. Up to three adjacent panels can be suspended at once. Do not exceed this number, otherwise the weight would be too high on the C-Profile.

MESH B-H 300 EASY

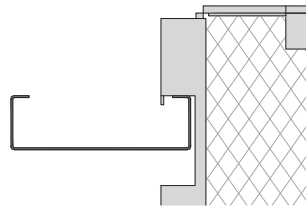

MESH B-H 300 MT EASY

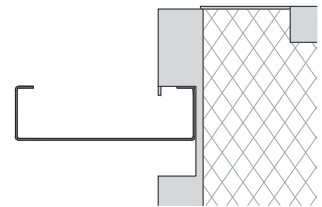

MESH B-H 300 / MESH B-H 300 MT

Direct suspended C-Profile

Exposed linear grid solution for indoor applications

General information

- Exposed hook-on linear grid system for medium rooms
- For perpendicular or radial installation
- C-Profile 100 mm in RAL 9010 made of galvanised steel (further sizes, cut-outs and colour options on request)
- Typical ceiling weight 8.5 - 10.0 kg/m² (indicative value for panels, without additional load)
- Panels are easily installed and fully demountable
- Hinge-down option
- Tartan grid layout option
- Long side suspended option
- MESH B-H 300 MT Megapanel option (up to 1200 x 1202 mm)

Isometric view

Select the suspension option C1 - C2.
Perimeter solutions on separate datasheet.

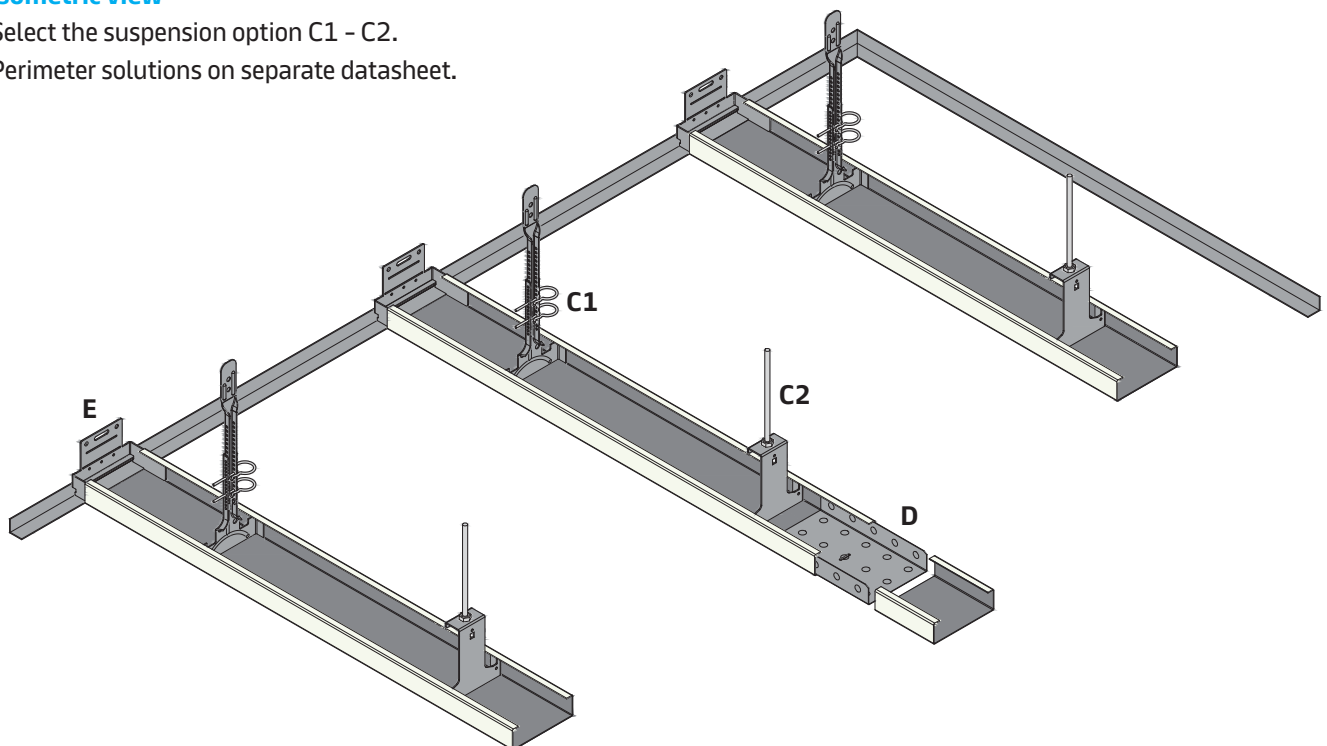

The use of a primary grid system is recommended, as this simplifies levelling and the alignment of the ceiling.

Vario Design & bespoke layout options

Vario Design

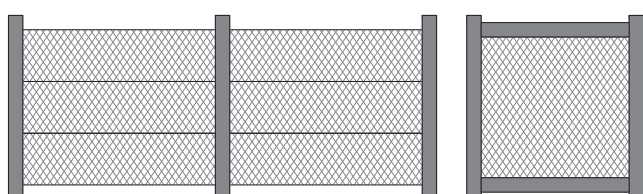

Bespoke (on request)

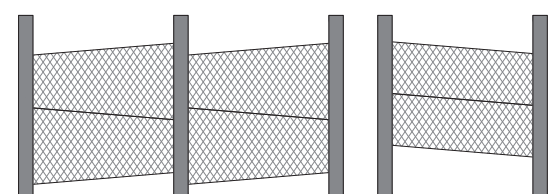

MESH B-H 300 / MESH B-H 300 MT
D03.004.1

Section A (MESH B-H 300)

Example with suspension option C2

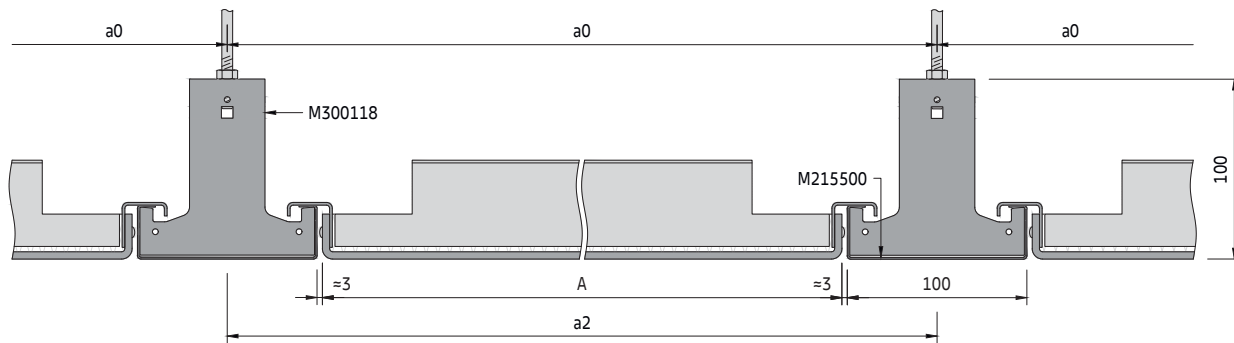

The panels should be installed with a ≈ 3 mm open gap on the short sides, which enables installation.

Section A (MESH B-H 300 MT)

Example with suspension option C2

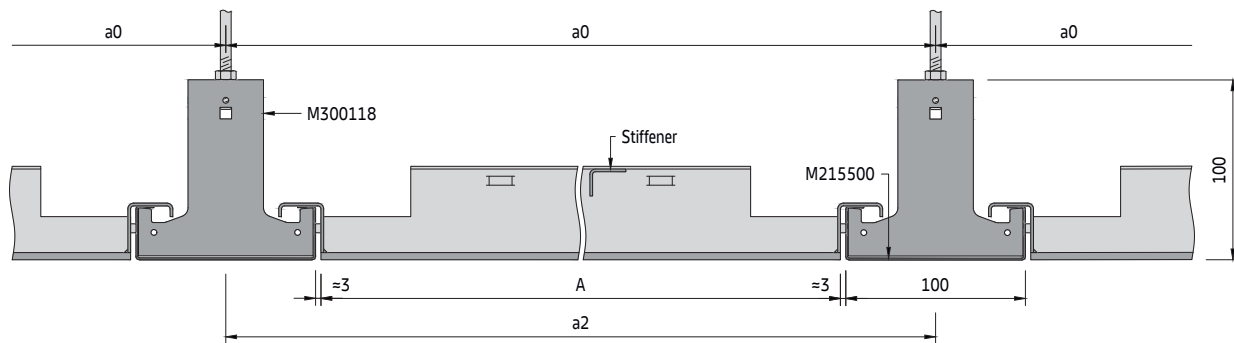

The panels come standard with a ≈ 3 mm spacer on the short sides. Panels >2000 mm length with additional welded stiffener.

Secondary grid components

Standard components:

- M215500 C-Profile 100 mm RAL 9010
- M300144 Wall anchor for C-Profile 100 mm
- M311067 Splice connector for C-Profile 100 mm

Suspension option C2:

- M300078 Nonius hanger for C-Profile 100 mm
- - Nonius top part (various lengths)
- M300036 Nonius locking pin

Suspension option C1:

- M300118 Hanger for C-Profile 100 mm
- M311101 Threaded rod M6 x 1000 mm
- M311103 Hexagonal nut M6
- M311315 Hexagonal extension nut M6 x 30 mm (optional)
- M311061 Suspension element (optional)

Optional components

- M311191 Self-drilling screw 3.5 x 9.5 mm

C-Profile 100 mm secondary grid

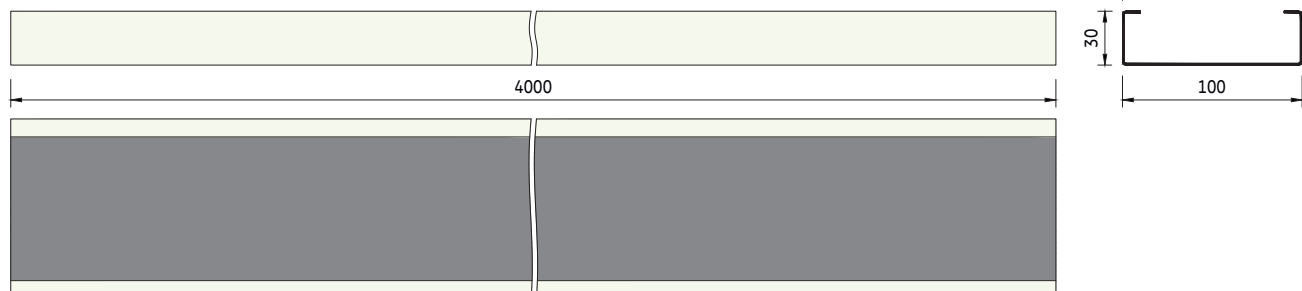

MESH B-H 300 / MESH B-H 300 MT

D03.004.1

Section B (MESH B-H 300)

Example with suspension option C2

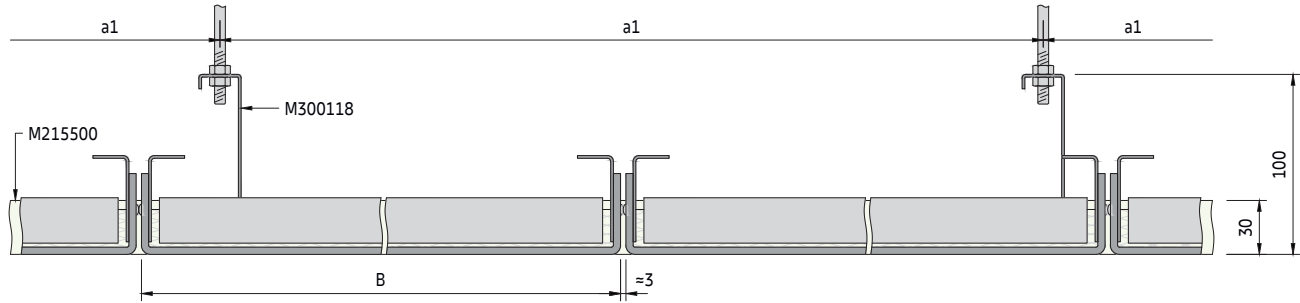

The panels should be installed with a ≈ 3 mm open gap on the long side, which enables installation.

Section B (MESH B-H 300 MT)

Example with suspension option C2

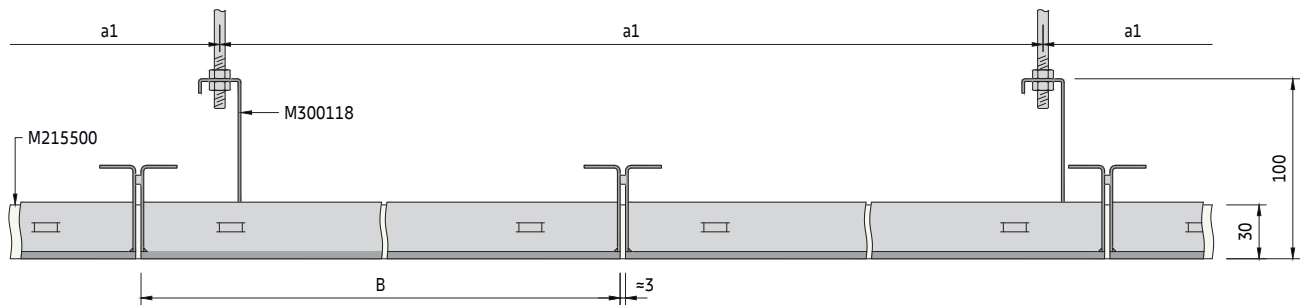

The panels come standard with a ≈ 3 mm spacer on the long side.

MESH B-H 300 / MESH B-H 300 MT
D03.004.1

Spacing

a2 [mm]	System without additional load		System with additional load +4 kg/m²	
	a0 [mm]	a1 [mm]	a0 [mm]	a1 [mm]
600	1200	1700	1200	1250
650	1300	1450	1300	1100
700	1400	1250	700	1800
750	1500	1100	750	1750
800	800	1800	800	1700
850	850	1750	850	1650
900	900	1700	900	1600
950	950	1700	950	1550
1000	1000	1650	1000	1500
1050	1050	1600	1050	1500
1100	1100	1550	1100	1450
1150	1150	1550	1150	1400
1200	1200	1500	1200	1350
1250	1250	1500	1250	1250
1300	1300	1500	1300	1150
1350	1350	1450	1350	1050
1400	1400	1350	1400	1000
1450	1450	1250	1450	900
1500	1500	1200	1500	850
1550	1550	1100	1550	800
1600	1600	1050	1600	750
1650	1650	950	1650	700
1700	1700	900	1700	650
1750	1750	800	1750	600
1800	1800	750	900	1150
1850	1850	650	925	1150
1900	950	1200	950	1100
1950	975	1200	975	1100
2000	1000	1200	1000	1100
2050	1025	1150	1025	1100
2100	1050	1150	1050	1050
2150	1075	1150	1075	1050
2200	1100	1150	1100	1050
2250	1125	1100	1125	1050
2300	1150	1100	1150	1000
2350	1175	1100	1175	1000
2400	1200	1100	1200	1000
2450	1225	1050	1225	1000
2500	1250	1050	1250	1000

Parameters

- a0 Distance between C-Profile suspension points = max. 1900 mm
- a1 Max. distance between C-Profile hangers
- a2 Distance between C-Profile 100 mm
- a3 Distance from wall = max. 200 mm
- a4 Distance from wall = max. panel length
- M Module size = C-Profile width + panel length + 2x ≈ 3 mm gap / panel width + ≈ 3 mm gap
- A Panel length = min. 597 / max. 2500 mm *
- B Panel width = min. 247 / max. 700 mm *

* The dimensions depend on the chosen system and mesh pattern

Typical grid layout

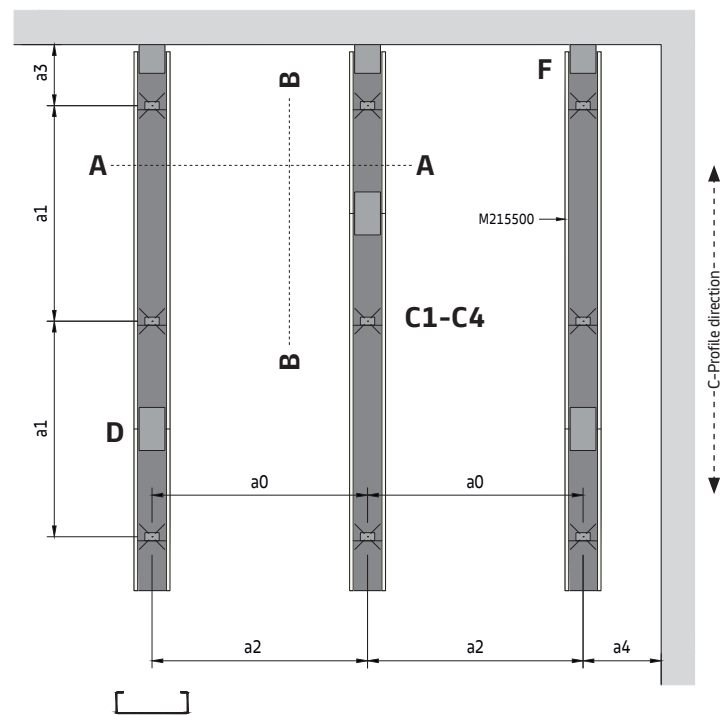

To determine suspension layout

The module length (M) of the requested ceiling is equal to the distance between the C-Profile centres (a2).

On the appropriate spacing table, read down the column headed (a2) to the required module length then read across to determine the suspension point spacing (a0) and C-Profile hanger spacing (a1).

The shown values are maximum allowed distances and can be reduced but not exceeded.

Detail C
Hanger installation

Option C1

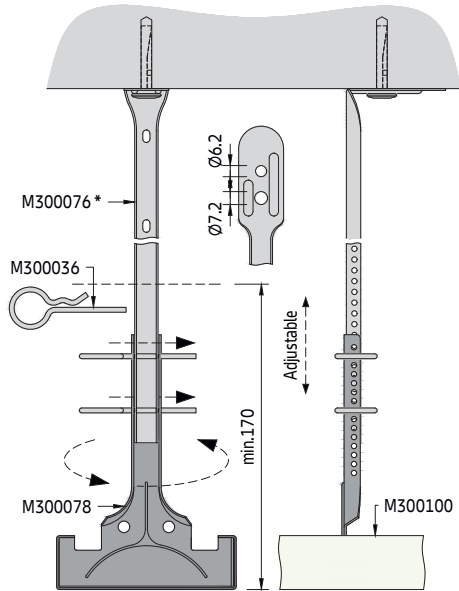

Twist the Nonius hanger on the C-Profile from above. Fix the C-Profile with the Nonius hangers to the Nonius top parts by using Nonius locking pins.

Option C2

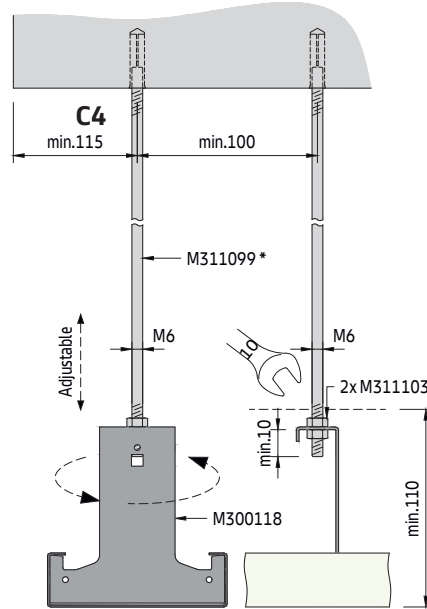

Fix the hanger to the threaded rod, in an angle of approx. 45°. The upper hexagonal nut defines the height of the ceiling, the bottom one is positioned with a small gap between the hanger and the upper hexagonal nut. Insert the C-Profile from below and twist the hanger to the end position, perpendicular to the C-Profile. Lock the position of the hanger by tighten the bottom hexagonal nut.

Detail C4

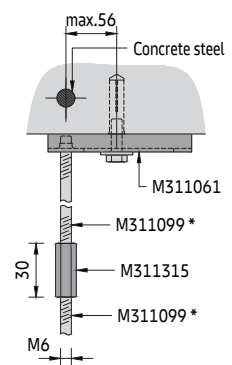

* Various lengths available

Angle bracing option

Detail C3

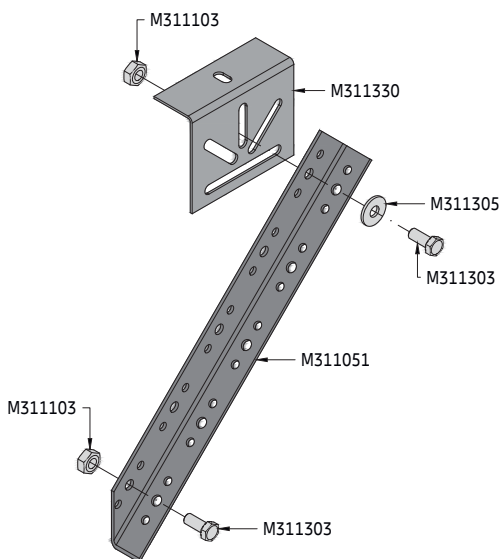

For suspension option C1

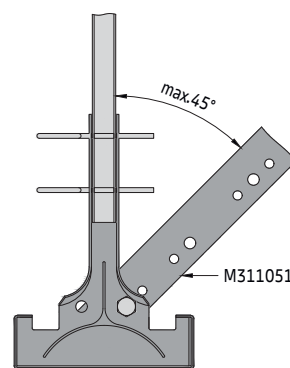

For suspension option C2

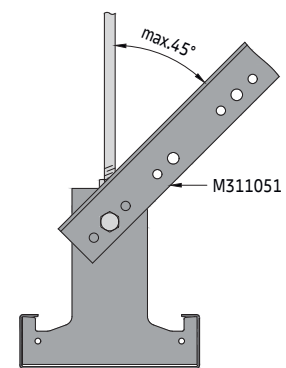

The use of angle bracings is recommended and prevents the C-Profiles from swinging and makes the installation safer. A minimum of two angle bracings per C-Profile row is needed.

Minimum pull-out force per suspension point = 1.25 kN (failure state)

Maximum permissible load per suspension point = 0.50 kN (incl. 2.5 times safety). These values must always be observed and guaranteed by the installation company for each suspension point irrespective of the type of hanger selected.

MESH B-H 300 / MESH B-H 300 MT
D03.004.1

Detail D
Splice connection

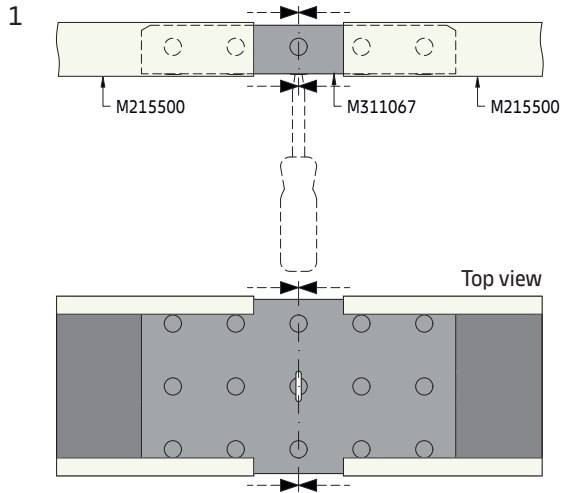

The connectors for the C-Profile must be inserted from the end. Make sure the connector is centered. To make centering easier you can use a screwdriver to adjust the position using the slot in the connector.

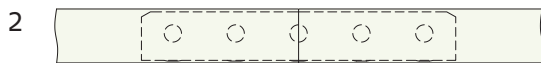

The ends of the C-Profiles should be brought together without a gap. Stagger the joints.

Material required per m² (no waste included)
System without additional load [pcs/m²]

Components	a2 [mm]	1200	1600	1800	2000	2200	2500
M215500	C-Profile 100 mm RAL 9010	0.21	0.16	0.14	0.13	0.12	0.10
M300144	Wall anchor for C-Profile 100 mm	0.18	0.14	0.12	0.12	0.10	0.10
M311067	Splice connector for C-Profile 100 mm	0.21	0.16	0.14	0.13	0.12	0.10
Various	Suspension points (E1 - E4)	0.56	0.60	0.75	0.42	0.40	0.39

The shown quantities are theoretical and based on an ideal layout, without considering the actual room layout. The ideal layout is based on a calculation of 10 x 10 m (100 m²). This calculation does not allow any damage, spare nor wastage. The final quantities and type of suspension have to be checked before ordering. Soffit and wall fixings by others. Not including perimeter trims, optional security brackets and extraction tools.

MESH B-H 300 / MESH B-H 300 MT

D03.004.1

Detail E

Wall anchor installation

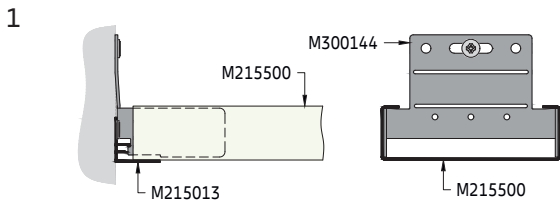

The wall anchor prevents the C-Profile from swinging and thus contributes to the safe installation of the substructure. The wall anchor has no load-bearing function and is only attached to one end of the room to secure the C-Profile.

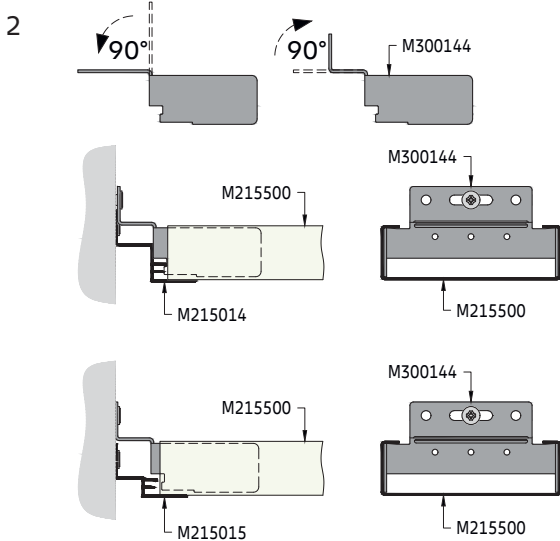

When using a shadowline perimeter trim, the upper part must first be bent 90° down and then 90° up again, so that a step is created.

Detail F

Cross-connector installation for tartan grid layout option

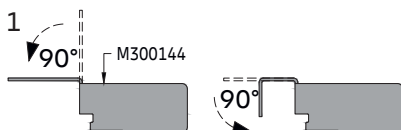

With the cross-connector, a tartan grid layout can be simulated without using crossing-boxes. Bend the upper part of the hanger twice by 90° until a hook is formed.

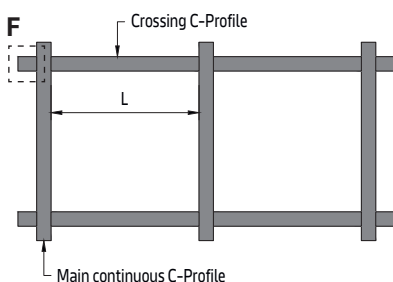
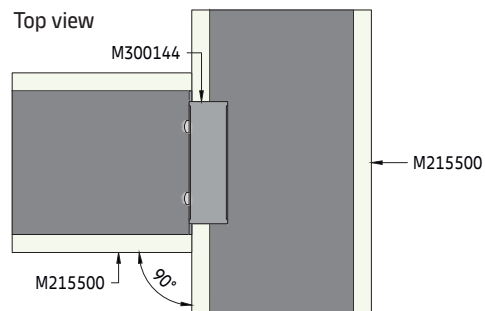
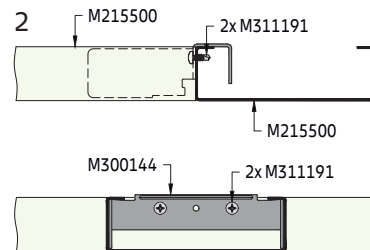

Use two self-drilling screws to attach the hanger to the C-Profile. C-Profiles cut to length are installed across the continuous C-Profiles. Crossing C-Profile (L) = module length - C-Profile width

MESH B-H 300 / MESH B-H 300 MT

D03.004.1

Detail G

Panel insertion (example with MESH B-H 300)

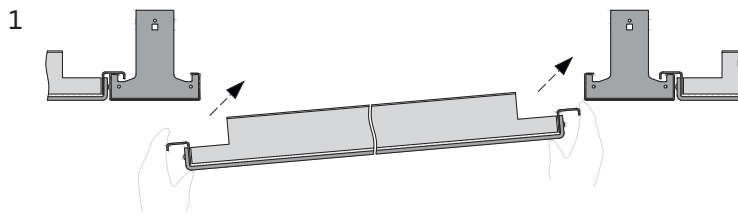

Insert the panel at a slight angle, above the C-Profile.

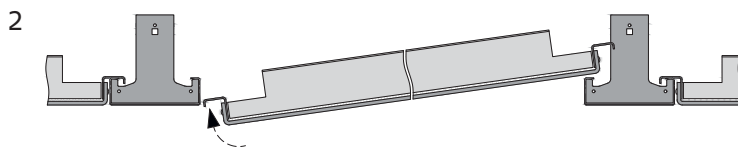

Lift up the opposite end of the panel above the opposite C-Profile.

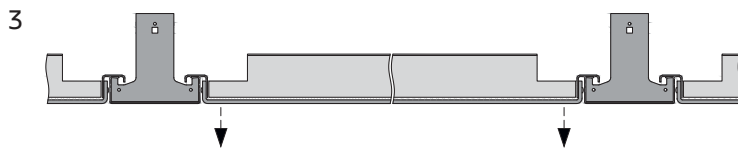

Rest the panel on the C-Profiles.

Panel extraction (example with MESH B-H 300)



With a closed ceiling, any panel can be removed as long as there are no obstacles such as service integrations, etc.

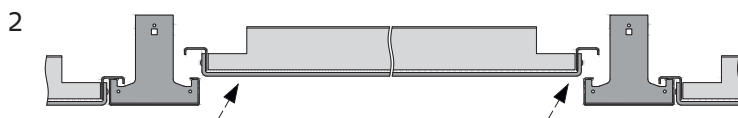

Lift the panel above the C-Profile.

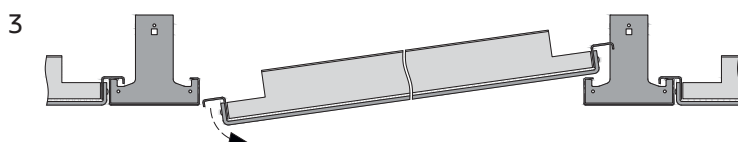

Lower the opposite side.

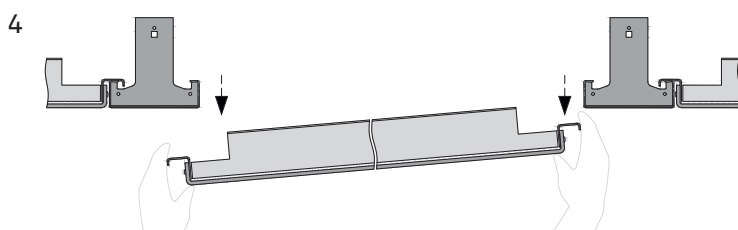

Remove it downwards and store the panel in a safe place so that it cannot be damaged.

MESH B-H 300 / MESH B-H 300 MT

D03.004.1

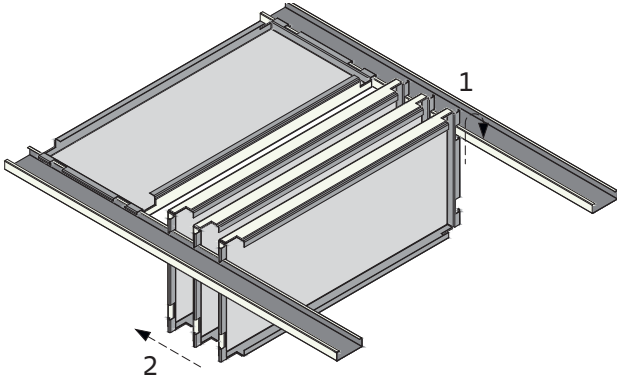
Detail H**Hinge-down option (example with MESH B-H 300 EASY)**

- 1 Extract the panel as shown under Detail G and hang it back vertically on the C-Profile. The panels hinge-down over the long side.
- 2 Move the panel aside to allow access to the plenum. Up to three adjacent panels can be suspended at once. Do not exceed this number, otherwise the weight would be too high on the C-Profile.

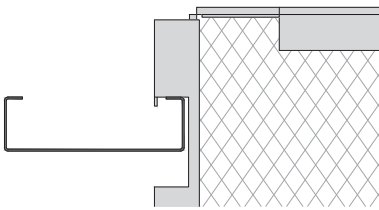
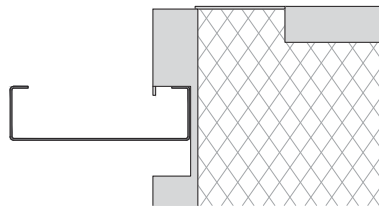
MESH B-H 300 EASY**MESH B-H 300 MT EASY**



MESH K-H 400
65 Gresham Street, United Kingdom © Tom Green

MESH K-H 400 / MESH K-H 400 MT

Crossing box + C-Profile

Exposed tartan grid solution for indoor applications

General information

- Exposed hook-on tartan grid system for large rooms
- Crossing box and C-Profile 100 mm in RAL 9010 made of galvanised steel (further sizes, cut-outs and colour options on request)
- Typical ceiling weight 10.0 - 12.0 kg/m² (indicative value for panels, without additional load)
- Panels are easily installed and fully demountable
- Hinge-down option
- MESH K-H 400 MT Megapanel option (up to 1200 x 1202 mm)

Isometric view

Perimeter solutions on separate datasheet.

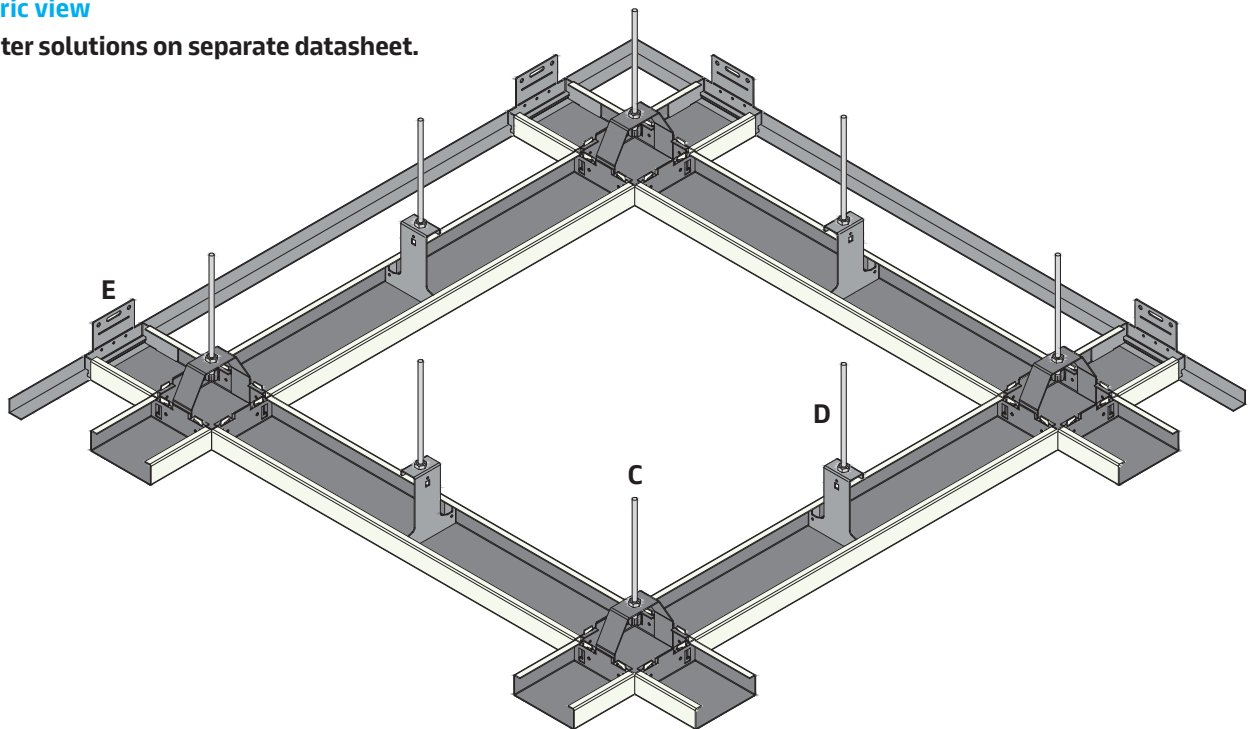

Vario Design & bespoke layout options

Vario Design

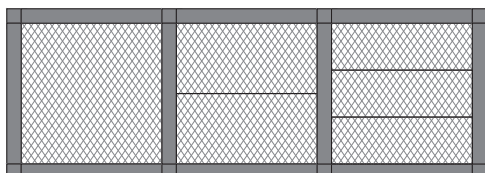

Bespoke (on request)

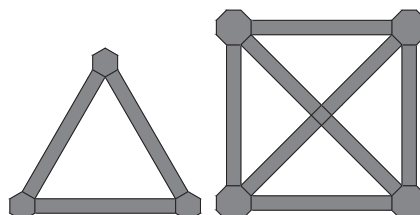

MESH K-H 400 / MESH K-H 400 MT
D03.005

Section A (MESH K-H 400)

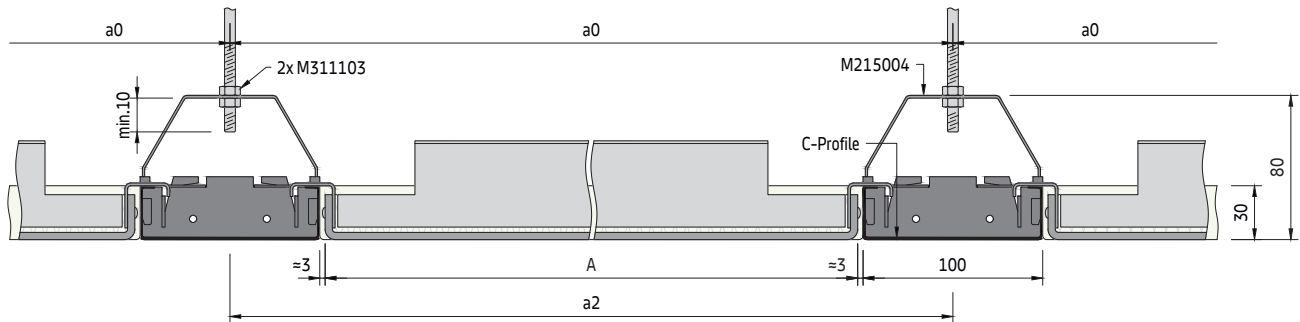

The panels should be installed with a ≈ 3 mm open gap on the short sides, which enables installation.

Section A (MESH K-H 400 MT)

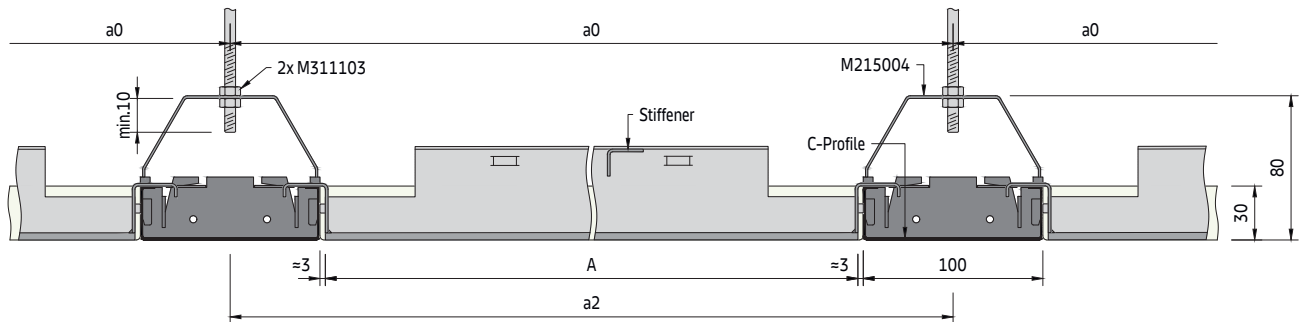

The panels come standard with a ≈ 3 mm spacer on the short sides. Panels >2000 mm length with additional welded stiffener.

Secondary grid components

Standard components:

- M215004 Crossing box 100 x 100 mm RAL 9010
- - C-Profile L x 100 mm RAL 9010
- M300118 Hanger for C-Profile 100 mm
- M300144 Wall anchor for C-Profile 100 mm
- M311103 Hexagonal nut M6
- M311105 Washer
- M311303 Hexagonal bolt M6 x 16 mm

Optional components:

- M311307 Pop-Rivet TAPD 44 BS

Crossing box 100 x 100 mm

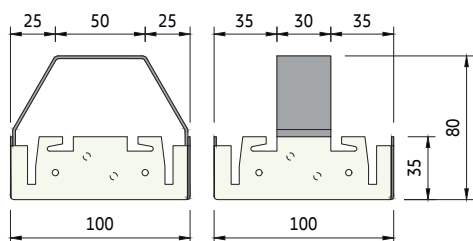

C-Profile 100 mm

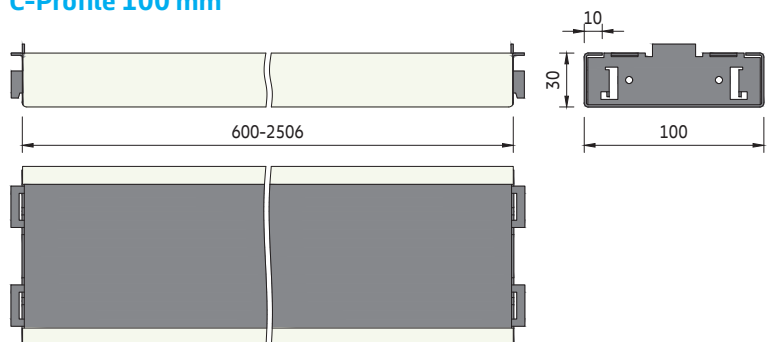

MESH K-H 400 / MESH K-H 400 MT

D03.005

Section B (MESH K-H 400)

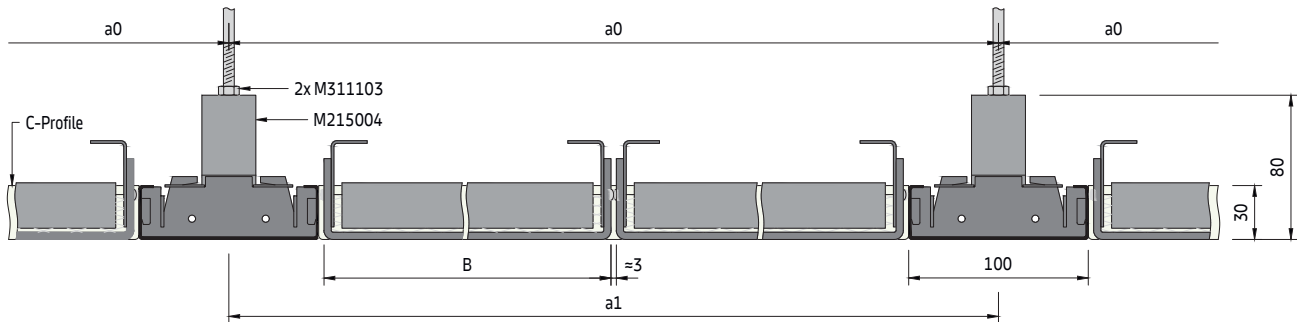

The panels should be installed with a ≈ 3 mm open gap on the long side, which enables installation.

Section B (MESH K-H 400 MT)

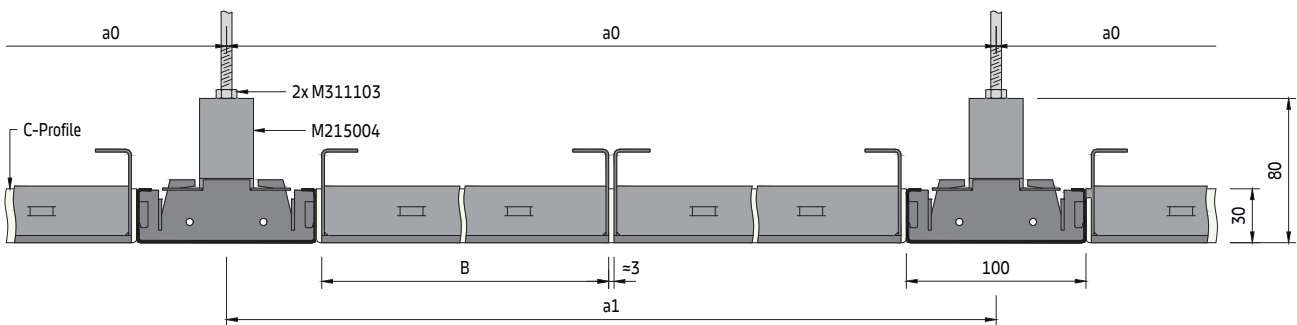

The panels come standard with a ≈ 3 mm spacer on the long side.

MESH K-H 400 / MESH K-H 400 MT
D03.005

Parameters

- a0 Distance between crossing box suspension points = max. 1900 mm (if a1 or a2 is larger than a0 max., then the C-Profile will require additional suspension)
- a1 Distance between C-Profile 100 mm
- a2 Distance between C-Profile 100 mm
- a3 Distance from wall (if the distance is larger than 600 mm, then the C-Profile will require additional suspension)
- a4 Panel length = min. 597 / max. 2500 mm *
- a5 Panel width = min. 247 / max. 700 mm *
- M Crossing box length = standard 100 mm, min. 70 / max. 300 mm
- A Crossing Box width = standard 100 mm, min. 70 / max. 300 mm

* The dimensions depend on the chosen system and mesh pattern

The layout of the ceiling does not necessarily have to be square. The distance (a1) and (a2) can deviate from each other. This also results in different distances for (a0).

The same applies to the crossing box. This is usually square, but can also be supplied rectangular on request.

Typical grid layout

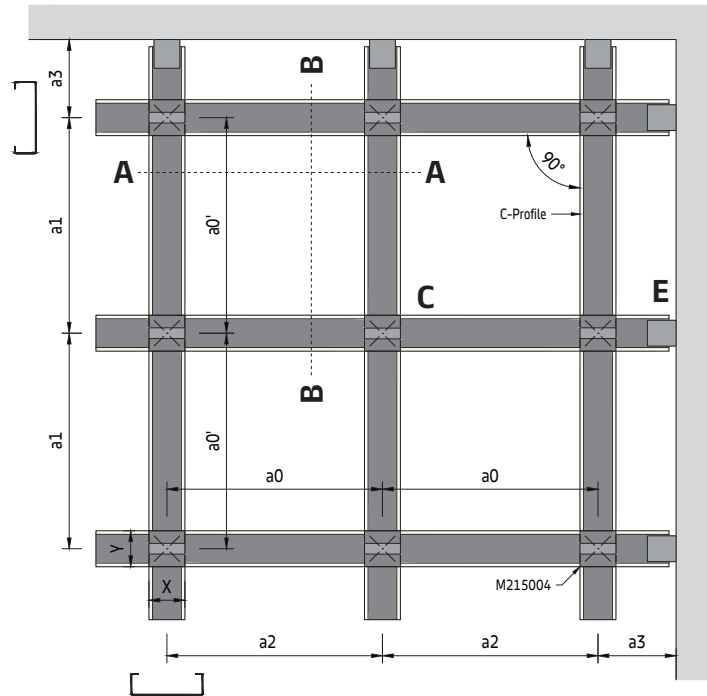

Crossing box & C-Profile options

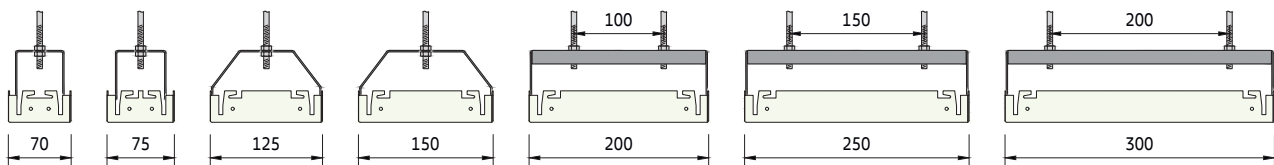

Crossing boxes and C-Profiles can be supplied in different sizes on request. For widths greater than 150 mm, two threaded rods are required for suspension. Crossing boxes with cut-outs, hexagonal and octagonal shapes, etc. are available on request.

MESH K-H 400 / MESH K-H 400 MT
D03.005

Detail C

Crossing box installation

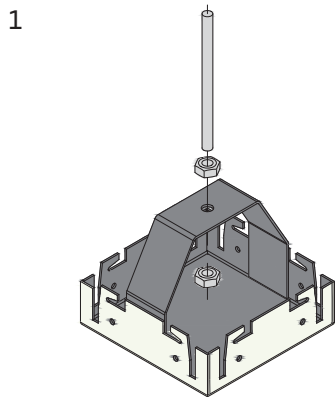

Set the threaded rods in the corners of the modules. Level the height of the ceiling using the top hexagonal nut. Insert the crossing box from below and secure using the second (lower) hexagonal nut. Align the crossing boxes.

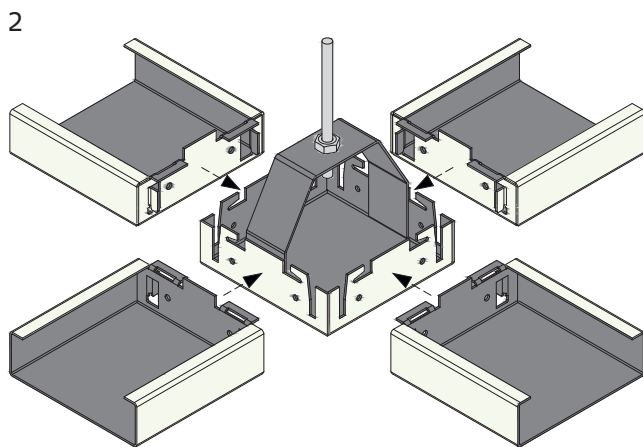

Connect the crossing boxes with the C-Profiles. To do this, use the two tabs at the ends of the C-Profiles and hook them in.

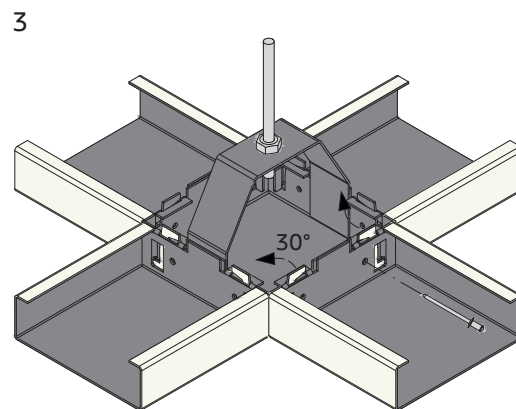

With pliers, the two tabs on the crossing box can be bent inwards by 30°. This secures the connection. Repeat the process to fix all C-Profiles. If the load is asymmetrical, the C-Profiles should also be fixed with two pop-rivets.

Detail D

Additional hanger installation

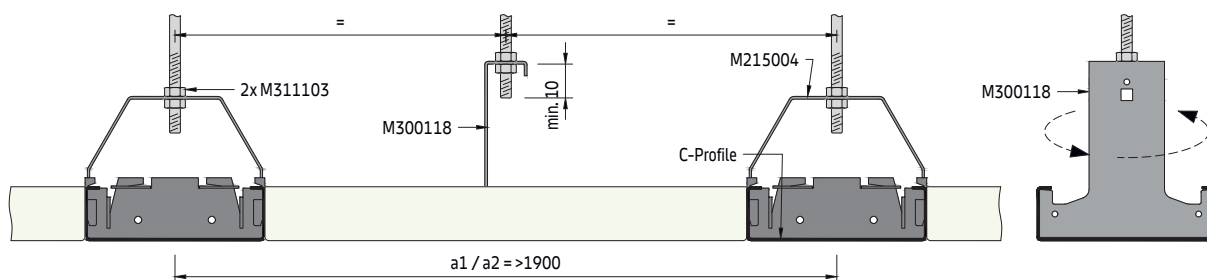

If the distance between the suspension points (a_0) is greater than 1900 mm, an additional hanger for C-Profile must be used. The same also applies to an additional load of +4 kg/m². A hanger is twisted in and suspended with a threaded rod. The hanger is ideally placed in the middle of the C Profile.

MESH K-H 400 / MESH K-H 400 MT
D03.005

Detail E

Wall anchor installation

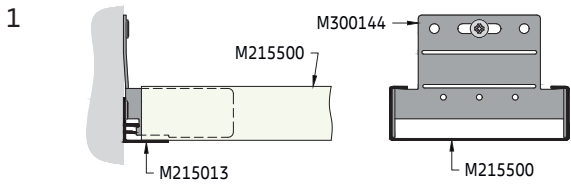

The wall anchor prevents the C-Profile from swinging and thus contributes to the safe installation of the substructure. The wall anchor has no load-bearing function and is only attached to one end of the room to secure the C-Profile.

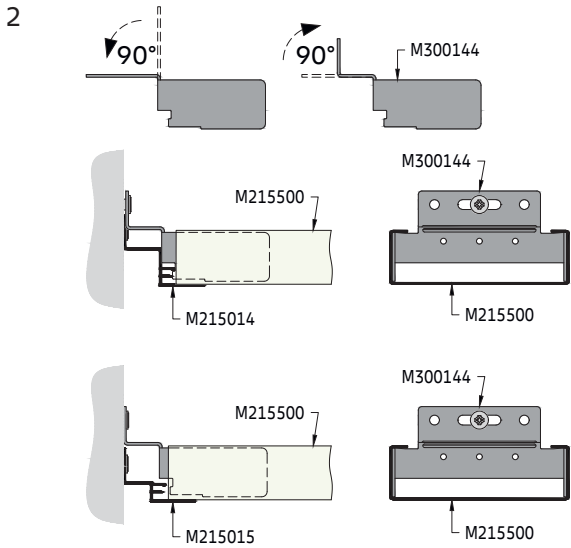

When using a shadowline perimeter trim, the upper part must first be bent 90° down and then 90° up again, so that a step is created.

Detail K

Cross-connector installation for tartan grid layout option

Perimeter detail max. 600 mm

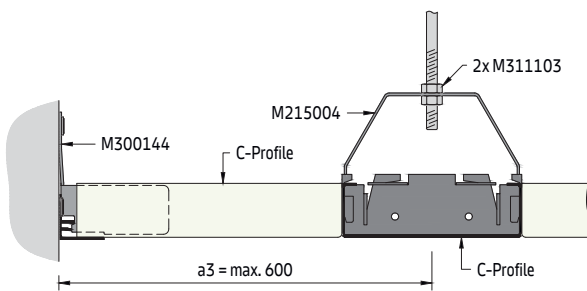

Perimeter detail 601 - 1900 mm with additional hanger

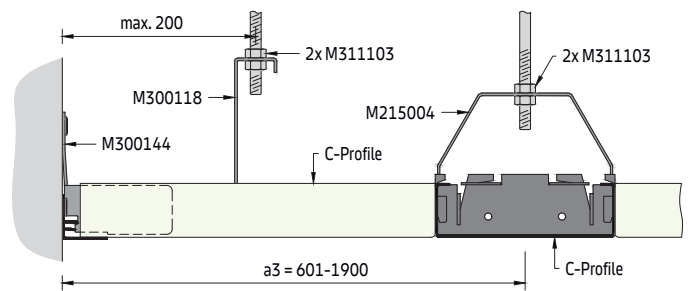

Perimeter detail 1901 - 2900 mm with additional hangers

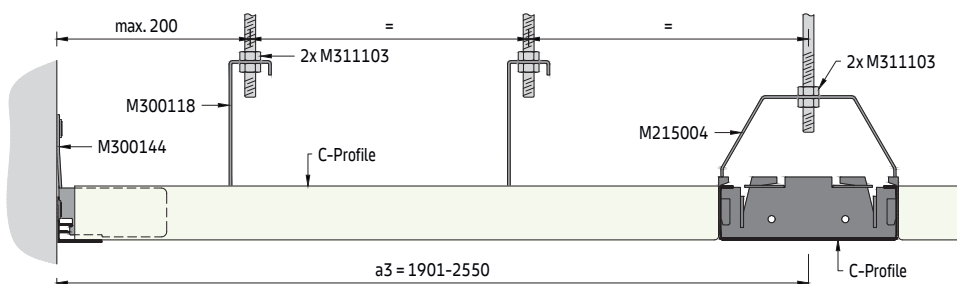

If the distance to the first suspension point (a3) is greater than 600 mm, then the C-Profile will require additional suspension. If the distance is greater than 1900 mm, two hangers are needed.

Detail G

Panel insertion (example with MESH K-H 400)

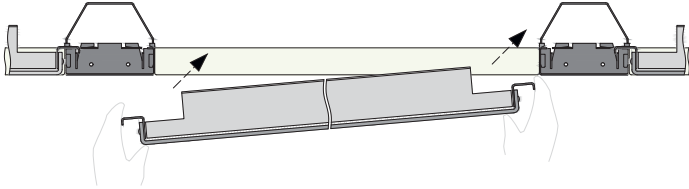
1  Insert the panel at a slight angle, above the C-Profile.

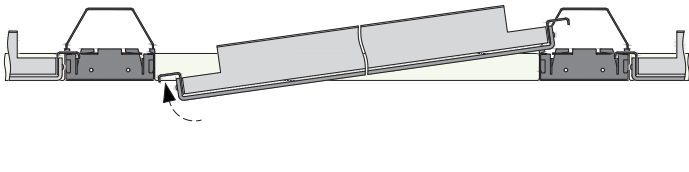
2  Lift up the opposite end of the panel above the opposite C-Profile.

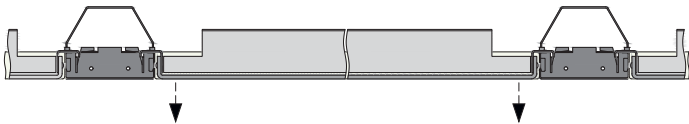
3  Rest the panel on the C-Profiles.

Panel extraction (example with MESH K-H 400)

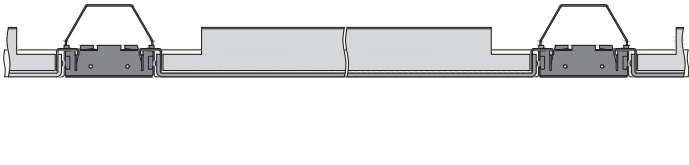
1  With a closed ceiling, any panel can be removed as long as there are no obstacles such as service integrations, etc.

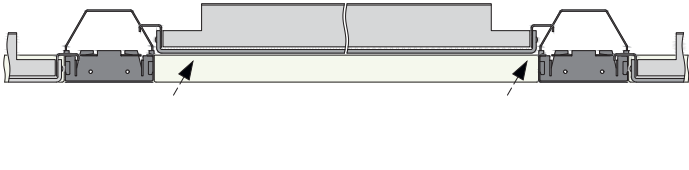
2  Lift the panel above the C-Profile.

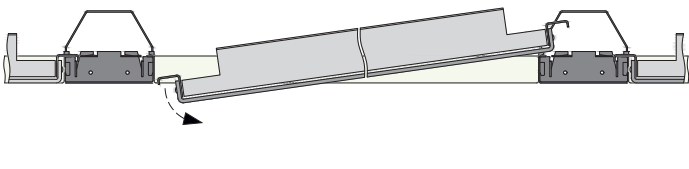
3  Lower the opposite side.

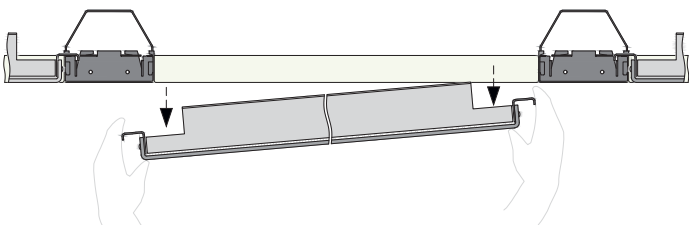
4  Remove it downwards and store the panel in a safe place so that it cannot be damaged.

MESH K-H 400 / MESH K-H 400 MT

D03.005

Detail H

Hinge-down option (example with MESH K-H 400 EASY)

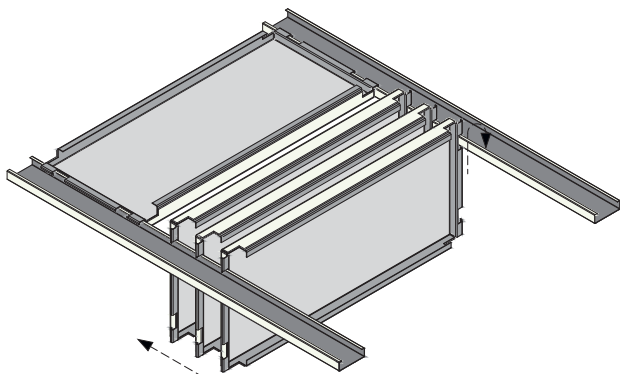

- 1 Extract the panel as shown under Detail L and hang it back vertically on the C-Profile. The panels hinge-down over the long side.
- 2 Move the panel aside to allow access to the plenum. Up to three adjacent panels can be suspended at once. Do not exceed this number, otherwise the weight would be too high on the C-Profile.

MESH K-H 400 EASY

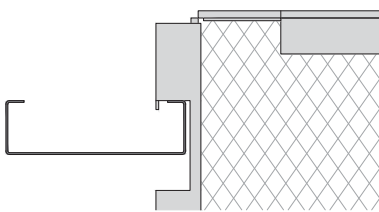

MESH K-H 400 MT EASY

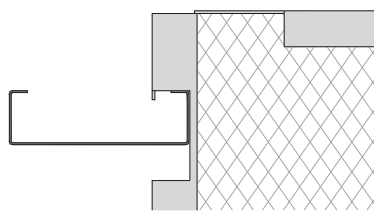

Material required per m² (no waste included)

System without additional load [pcs/m²]

Components	a2 [mm]	1200	1600	1800	2000	2200	2400	2400
M215004	Crossing box 100 x 100 mm RAL 9010	0.70	0.39	0.31	0.25	0.21	0.17	0.15
-	C-Profile L x 100 mm RAL 9010	1.67	1.25	1.11	1.00	0.91	0.83	0.77
M300118	Hanger for C-Profile 100 mm	-	-	-	0.5	0.42	0.35	0.30
M300144	Wall anchor for C-Profile 100 mm	0.28	0.24	0.20	0.20	1.60	1.60	1.20
M311099	Threaded rod M6 x 1000 mm	0.70	0.40	0.31	0.75	0.63	0.53	0.45
M311103	Hexagonal nut M6	1.40	0.80	0.62	1.50	1.26	1.06	0.90
M311105	Washer	0.70	0.40	0.31	0.75	0.63	0.53	0.45
M311303	Hexagonal bolt M6 x 16 mm	0.70	0.40	0.31	0.75	0.63	0.53	0.45

The shown quantities are theoretical and based on an ideal layout, without considering the actual room layout. The ideal layout is based on a calculation of 10 x 10 m (100 m²). This calculation does not allow any damage, spare nor wastage. The final quantities and type of suspension have to be checked before ordering. Soffit and wall fixings by others. Not including perimeter trims, optional components and extraction tools.



MESH R-H 200

L'Exception, Paris, France © Studio Vu



Concealed Grid Ceilings

MESH R-Clip

U-Profile primary grid + DP12 A-Bar secondary grid
Concealed grid solution for indoor applications

General information

- Concealed clip-in grid system for medium and large rooms
- For perpendicular installation on U-Profile primary grid
- DP12 A-Bar made of galvanised steel
- Typical ceiling weight 8.5 - 10.5 kg/m² (indicative value for panels, without additional load)
- Panels are easily installed and fully demountable
- Optional security clips available
- Staggered layout option

Isometric view

Select the suspension option E1 - E4.
Perimeter solutions on separate datasheet.

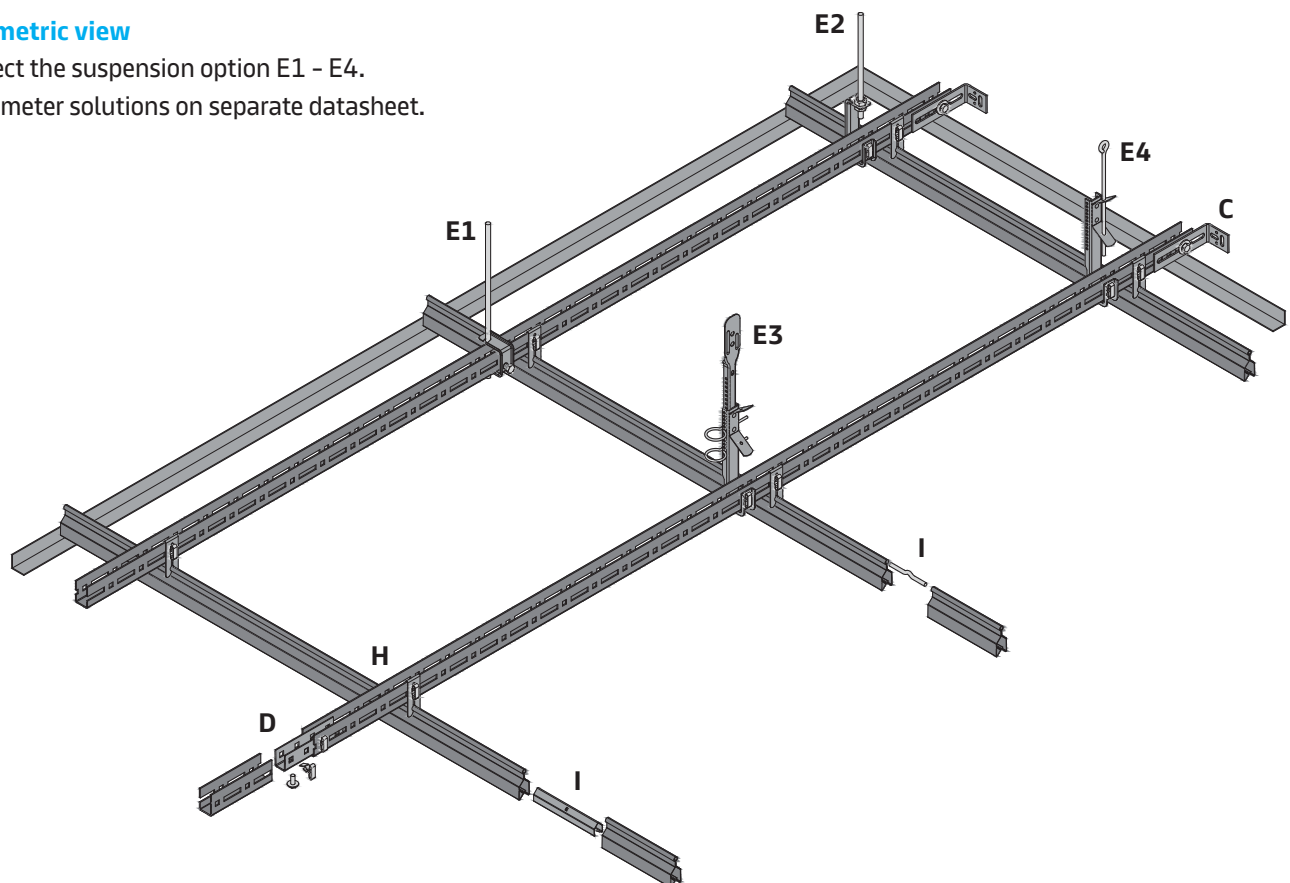

Vario Design layout options

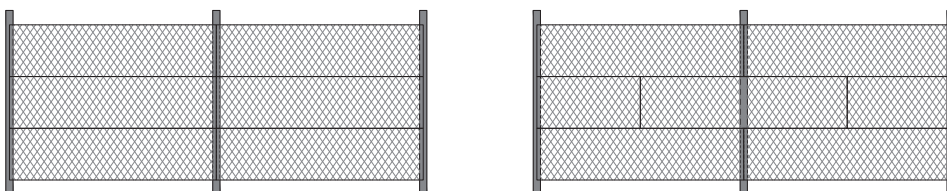

MESH R-Clip
D03.100

Section F

Example with suspension option E1

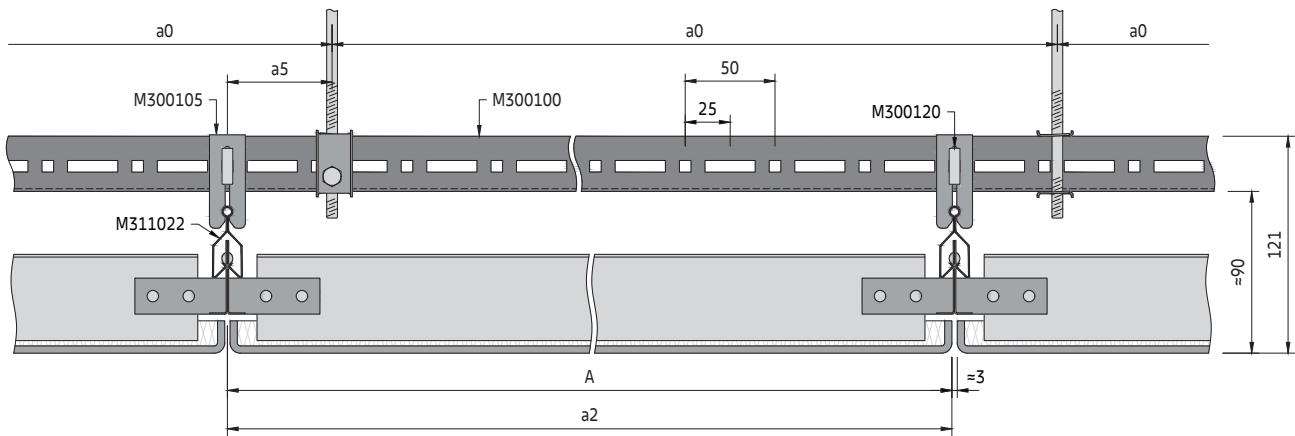

Section G

Example with suspension option E1

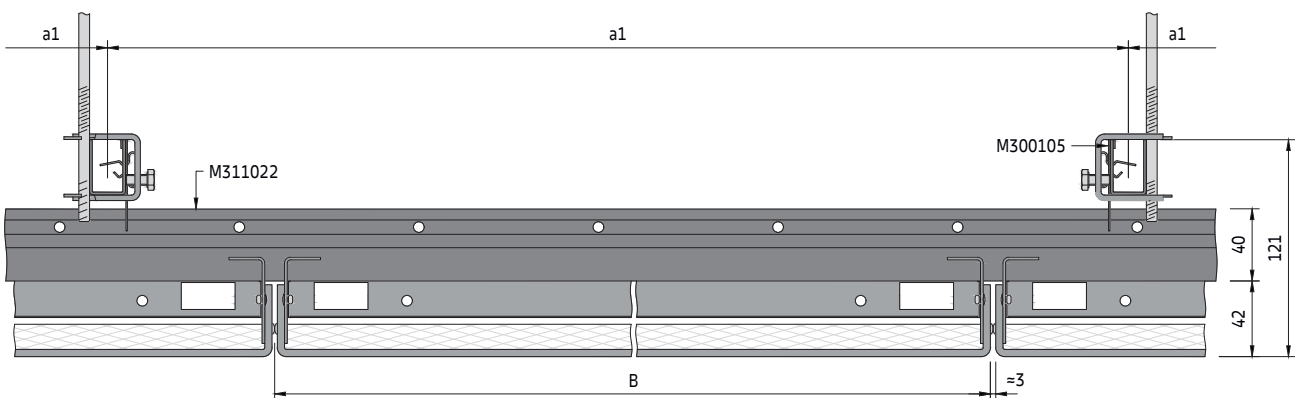

The panels should be installed with a ≈ 3 mm open gap on the long side, which enables installation.

Secondary grid components

Standard components:

- M311022 DP12 A-Bar
- M300138 Connection pin for DP12 A-Bar
- M300105 Hanger for DP12 A-Bar
- M300120 Plug-in clip for U-Profile

Optional components

- M300106 Security clip
- M311023 Splice connector for DP12 A-Bar
- M311046 Extraction tool
- M311191 Self-drilling screw 3.5 x 9.5 mm

See U-Profile primary grid for primary grid components

DP12 A-Bar secondary grid

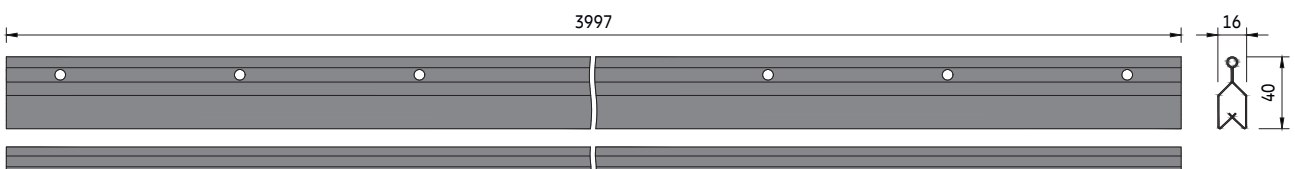

Spacing

a2 [mm]	System without additional load		System with additional load +4 kg/m ²	
	a0 [mm]	a1 [mm]	a0 [mm]	a1 [mm]
600	1200	1750	1200	1350
650	1300	1600	1300	1150
700	1400	1350	1400	1000
750	1500	1200	750	1400
800	1600	1050	800	1350
850	850	1500	850	1350
900	900	1450	900	1300
950	950	1400	950	1250
1000	1000	1400	1000	1250
1050	1050	1350	1050	1200
1100	1100	1300	1100	1200
1150	1150	1300	1150	1150
1200	1200	1250	1200	1150
1250	1250	1250	1250	1150
1300	1300	1200	1300	1100
1350	1350	1200	1350	1050
1400	1400	1150	1400	1050
1450	1450	1150	1450	950
1500	1500	1150	1500	900
1550	1550	1100	1550	850
1600	1600	1100	1600	750
1650	1650	1000	1650	700
1700	1700	950	1700	700
1750	1750	850	1750	600
1800	1800	700	1800	550
1850	1850	700	1850	500
1900	1900	650	1900	450
1950	975	1000	975	900
2000	1000	1000	1000	900
2050	1025	950	1025	850
2100	1050	950	1050	850
2150	1075	950	1075	850
2200	1100	950	1100	850
2250	1125	950	1125	850
2300	1150	900	1150	850
2350	1175	900	1175	800
2400	1200	900	1200	800
2450	1225	900	1225	800
2500	1250	900	1250	800

Parameters

- a0 Distance between C-Profile suspension points = max. 1900 mm
- a1 Max. distance between U-Profiles
- a2 Distance between DP12 A-Bars = panel length + ≈3 mm gap
- a3 Distance from wall = max. 200 mm
- a4 Distance from wall = max. panel length
- a5 Distance from U-Profile suspension point to hanger = max. 100 mm
- M Module size = panel length + ≈3 mm gap / panel width + ≈3 mm gap
- A Panel length = min. 600 / max. 2500 mm *
- B Panel width = min. 250 / max. 600 mm *

* The dimensions depend on the chosen system and mesh pattern

Typical grid layout

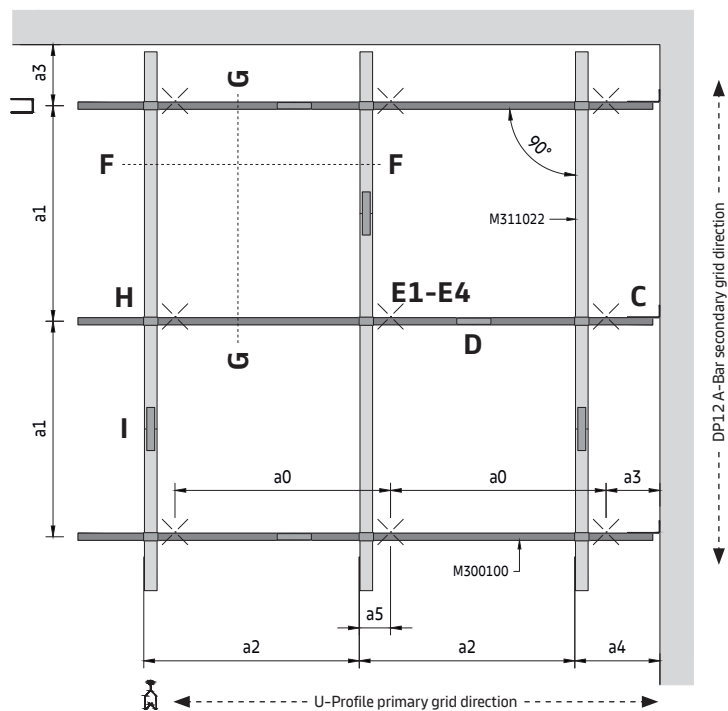

To determine suspension layout

The module length (M) of the requested ceiling is equal to the distance between the DP12 A-Bar centres (a2).

On the appropriate spacing table, read down the column headed (a2) to the required module length then read across to determine the suspension point spacing (a0) and U-Profile spacing (a1).

The shown values are maximum allowed distances and can be reduced but not exceeded.

MESH R-Clip
D03.100

Detail H

Hanger installation

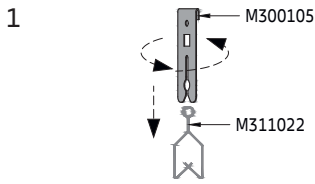

The hanger for DP12 A-Bar is made of spring steel and is therefore elastic. It is twisted on the DP12 A-Bar from above. Then it can be slid to the correct position.

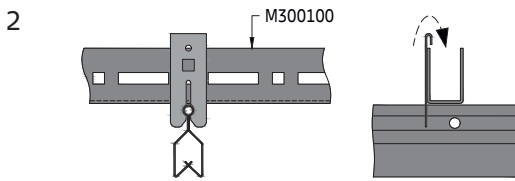

Hang the DP12 A-Bar with the hangers under the U-Profile.

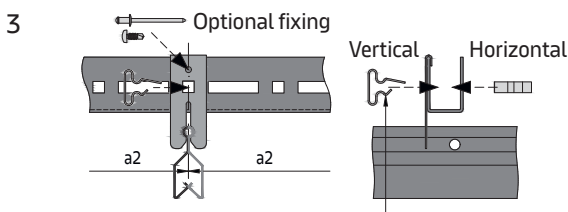

Fix hanger with plug-in clips at the specified module spacing (inserted vertically or horizontally). If the panel size does not fit with the modulation of the U-Profile (25 mm increments), the plug-in clip needs to be inserted into a long hole. The hanger position can alternatively be fixed by using a pop-rivet or self-drilling screw.

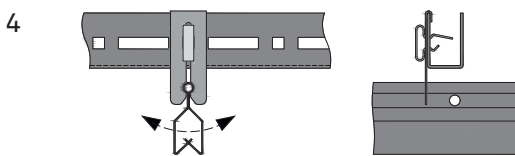

The DP12 A-Bar is now locked in position. Due to the round head of the DP12 A-Bar, it can swing. This is important because it allows any tolerances to be compensated. Otherwise the tiles / panels could no longer be inserted after a certain point.

Detail I

Splice connection

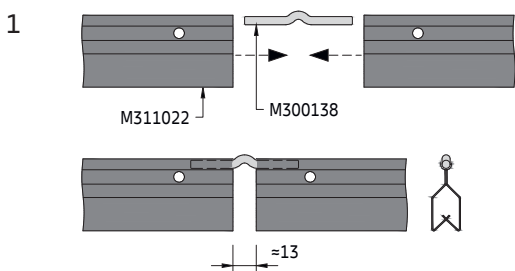

Insert the connection pin at the ends of the DP12 A-Bars and connect them. There is a gap between the DP12 A-Bars. The DP12 A-Bars must be aligned so that the joint is not in the same place as the pips on the tiles / panels.

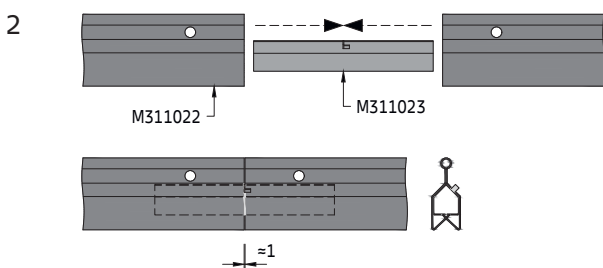

Optionally, the splice connector for DP12 A-Bar can be used. This is inserted at the ends of the DP12 A-Bars and an almost seamless connection is created.

MESH R-Clip
D03.100

Detail J

Panel insertion

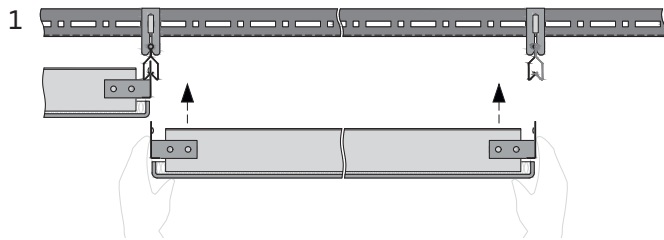

Take the panel and carefully insert it into the DP12 A-Bars from below. Be careful with the panels. Always press along the edges with the pips and never on the transverse sides, otherwise the panel may be damaged.

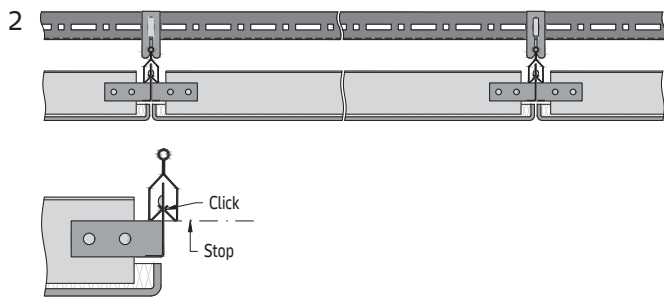

The panels are correctly inserted when all four corners are flush with the neighbouring panels. The panels are designed to match the DP12 A-Bar. If third party profiles are used there is a high probability the tiles will not be correctly inserted.

Panel extraction

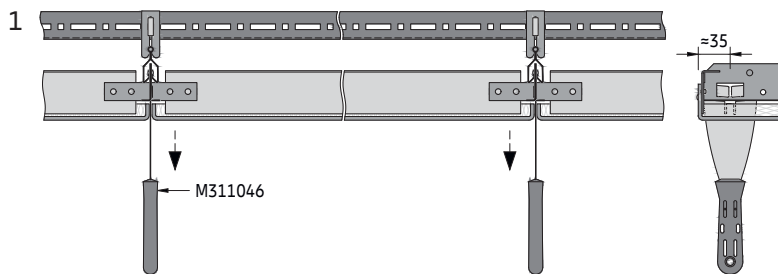

The panels are designed in such a way that the extraction tool can only be inserted in the designated places so that it clicks into place. There are two rectangular cut-outs on the short side of the panels. It is therefore important that the appropriate extraction tool is used. This prevents damage to the panels. Insert on one side first and pull down with a gentle tug, followed by the opposite side.

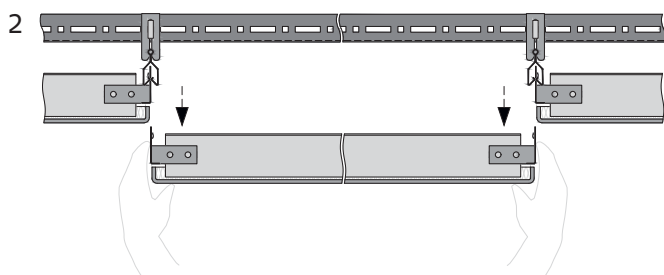

Remove it downwards and store the panel in a safe place so that it cannot be damaged.

MESH R-Clip
D03.100

Detail J

Optional security clip

The security clip serves to secure the panels and prevents them from being removed.

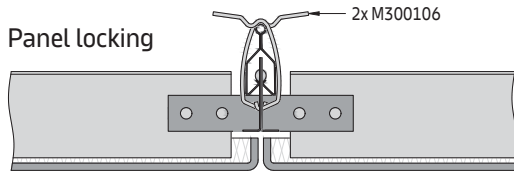

The panels have, on the sides where the pins are, a hole where the security clip can be fixed. First hook the security clip into the panel and then slip the upper end over the DP12 A-Bar. Two security clips are required per panel.

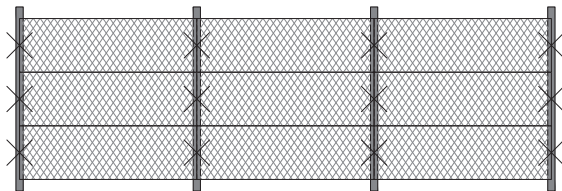

Either individual panels or the entire ceiling can be secured. The panels are inserted and secured immediately. The last panel cannot be locked.

Detail L

Staggered layout option (example with suspension option E1)

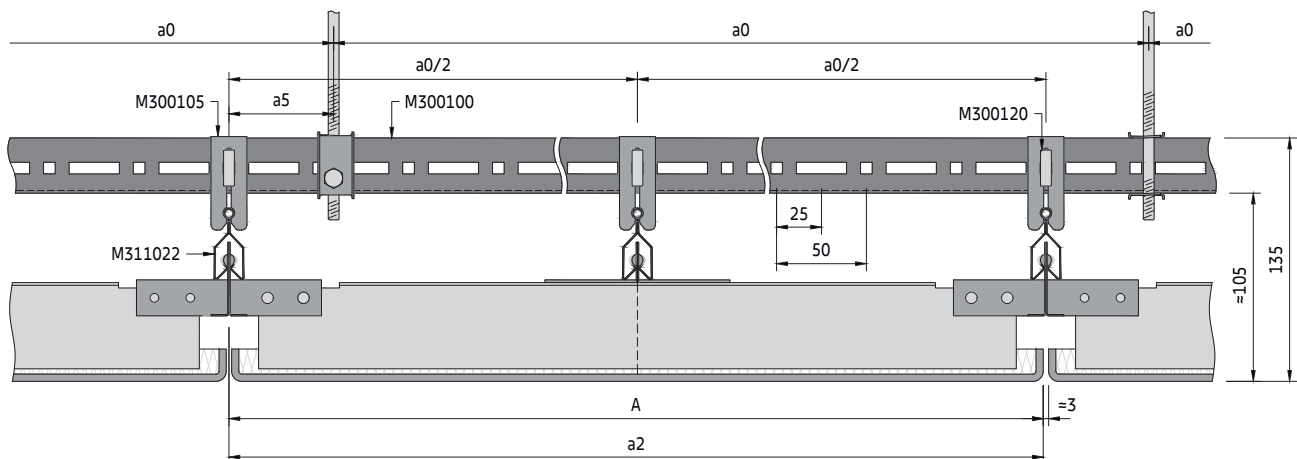

Material required per m² (no waste included)

System without additional load [pcs/m²]

Components	a2 [mm]	1200	1500	1800	2000	2500
M300100	U-Profile	0.21	0.23	0.33	0.27	0.30
M300105	Hanger for DP12 A-Bar	0.67	0.58	0.70	0.50	0.45
M300119	Splice connector for U-Profile	0.22	0.24	0.34	0.27	0.30
M300120	Plug-in clip for U-Profile	1.11	1.06	1.38	1.04	1.05
M300138	Connection pin for DP12 A-Bar	0.21	0.17	0.14	0.13	0.10
M300140	Wall anchor	0.09	0.09	0.13	0.11	0.12
M311022	DP12 A-Bar	0.21	0.17	0.14	0.13	1.00
M311103	Hexagonal nut M6	0.10	0.10	0.10	0.10	0.20
M311105	Washer	0.10	0.10	0.10	0.10	0.20
M311303	Hexagonal bolt M6 x 16 mm	0.10	0.10	0.10	0.10	0.20
Various	Suspension points (E1 - E4)	0.67	0.58	0.70	1.00	0.89

The shown quantities are theoretical and based on an ideal layout, without considering the actual room layout. The ideal layout is based on a calculation of 10 x 10 m (100 m²). This calculation does not allow any damage, spare nor wastage. The final quantities and type of suspension have to be checked before ordering. Soffit and wall fixings by others. Not including perimeter trims, optional security clips and extraction tools.

MESH R-Clip

DP12 A-Bar primary grid + DP12 A-Bar secondary grid
Concealed grid solution for indoor applications

General information

- Concealed clip-in grid system for medium and large rooms
- For perpendicular installation on DP12 A-Bar primary grid
- DP12 A-Bar made of galvanised steel
- Typical ceiling weight 8.5 - 10.5 kg/m² (indicative value for panels without additional load)
- Panels are easily installed and fully demountable
- Optional security clips available
- Staggered layout option

Isometric view

Select the suspension option D1 - D2.
Perimeter solutions on separate datasheet.

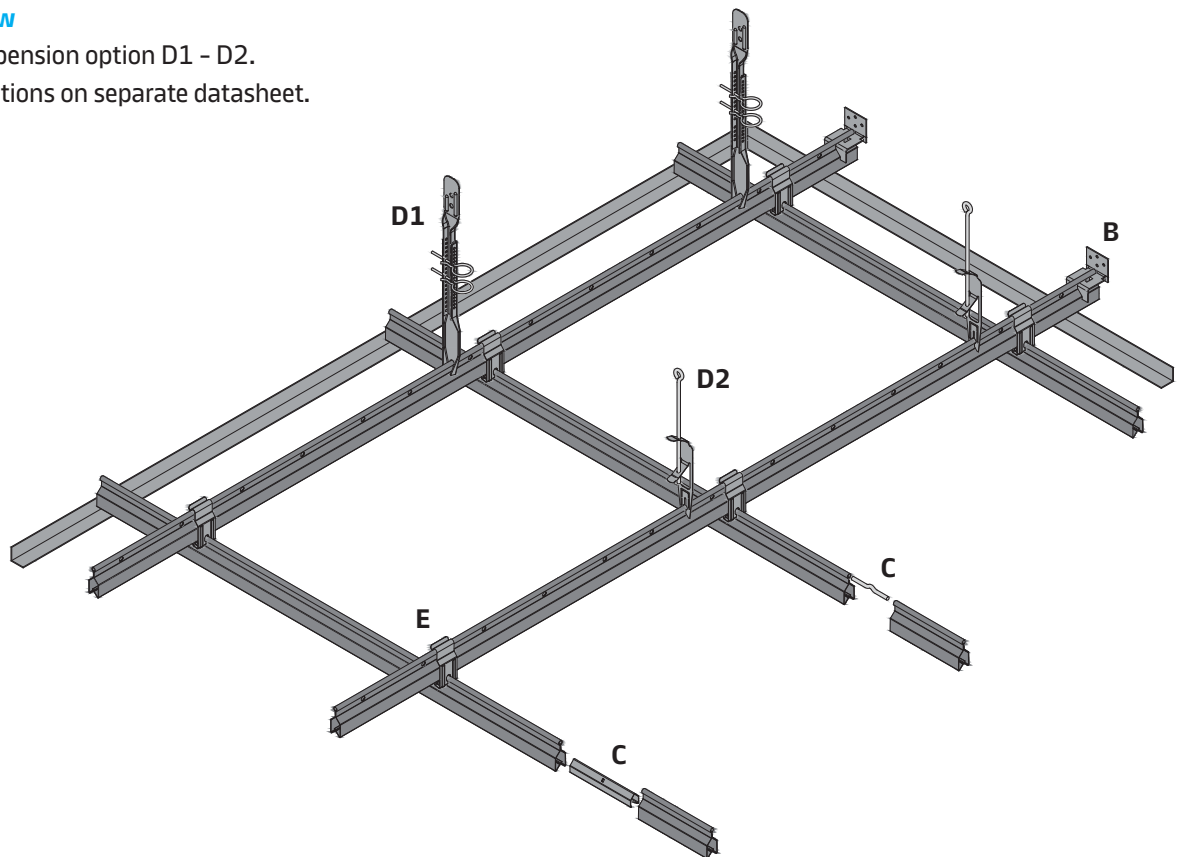

Vario Design layout options

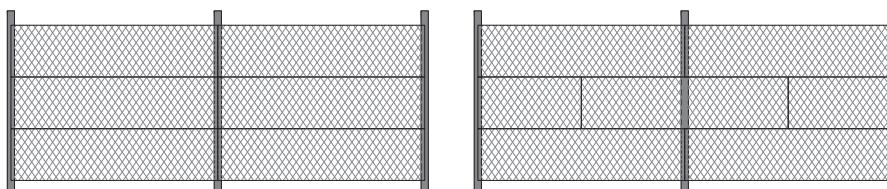

Section F

Example with suspension option D2

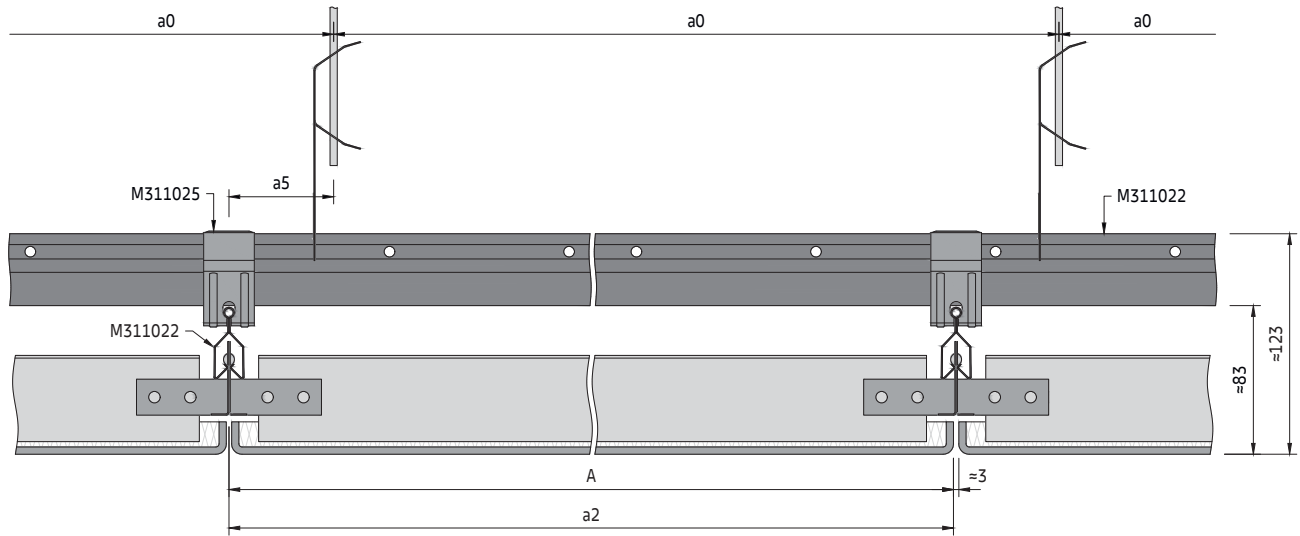

Section G

Example with suspension option D2

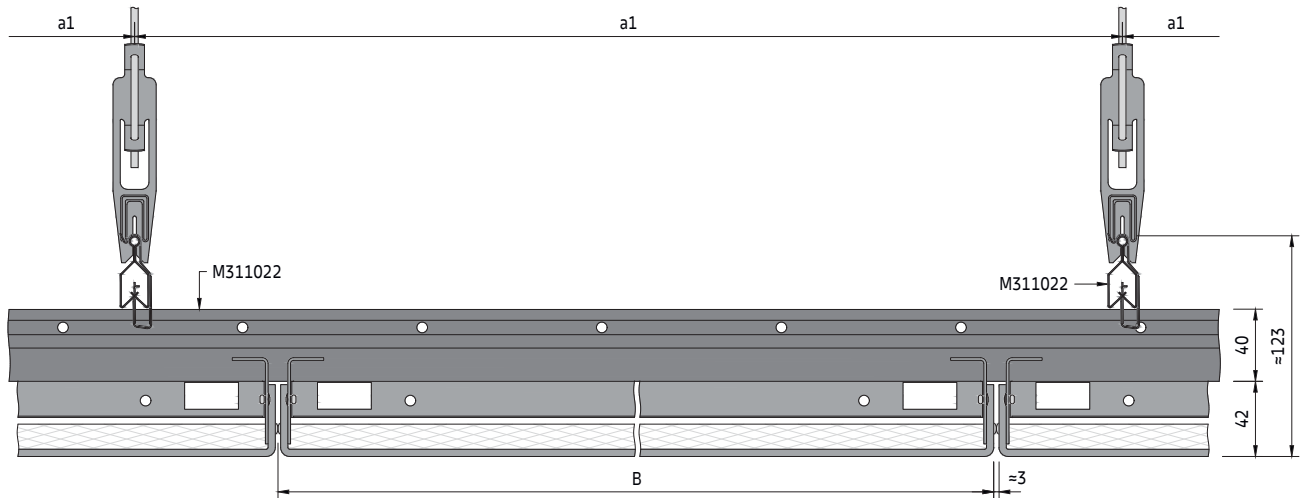

The panels should be installed with a ≈ 3 mm open gap on the long side, which enables installation.

Secondary grid components

Standard components:

- M311022 DP12 A-Bar
- M300138 Connection pin for DP12 A-Bar
- M311025 Cross connector for DP12 A-Bar

Optional components

- M300106 Security clip
- M311023 Splice connector for DP12 A-Bar
- M311046 Extraction tool

See DP12 A-Bar primary grid for primary grid components

DP12 A-Bar secondary grid

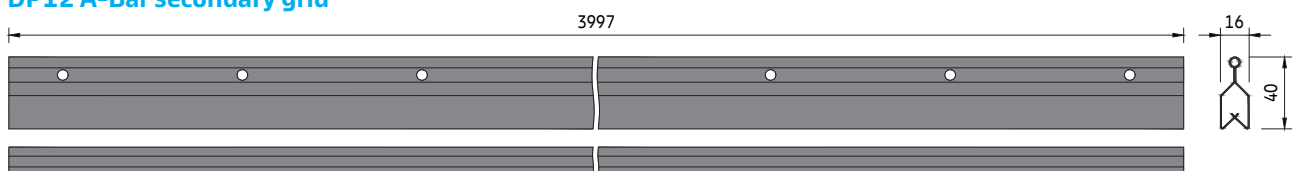

Spacing

a2 [mm]	System without additional load		System with additional load +4 kg/m ²	
	a0 [mm]	a1 [mm]	a0 [mm]	a1 [mm]
600	1200	1900	1200	1300
650	1300	1700	1300	1100
700	1400	1450	1400	950
750	1500	1300	750	1650
800	1600	1100	800	1600
850	850	1800	850	1550
900	900	1750	900	1550
950	950	1750	950	1500
1000	1000	1700	1000	1500
1050	1050	1700	1050	1450
1100	1100	1650	1100	1450
1150	1150	1650	1150	1450
1200	1200	1600	1200	1400
1250	1250	1600	1250	1250
1300	1300	1600	1300	1150
1350	1350	1550	1350	1100
1400	1400	1550	1400	1000
1450	1450	1450	1450	950
1500	1500	1350	1500	850
1550	1550	1250	1550	800
1600	1600	1150	1600	750
1650	1650	1100	1650	700
1700	1700	1000	1700	650
1750	1750	950	1750	600
1800	1800	850	1800	550
1850	1850	800	1850	500
1900	1900	700	1900	450
1950	975	1400	975	1200
2000	1000	1400	1000	1200
2050	1025	1400	1025	1200
2100	1050	1400	1050	1200
2150	1075	1350	1075	1200
2200	1100	1350	1100	1150
2250	1125	1350	1125	1150
2300	1150	1350	1150	1150
2350	1175	1300	1175	1150
2400	1200	1300	1200	1150
2450	1225	1300	1225	1100
2500	1250	1300	1250	1100

Parameters

- a0 Distance between DP12 A-Bar suspension points = max. 1900 mm
- a1 Max. distance between DP12 A-Bars
- a2 Distance between DP12 A-Bars = panel length + ≈3 mm gap
- a3 Distance from wall = max. 200 mm
- a4 Distance from wall = max. panel length
- a5 Distance from DP12 A-Bar suspension point to hanger = max. 100 mm
- M Module size = panel length + ≈3 mm gap / panel width + ≈3 mm gap
- A Panel length = min. 600 / max. 2500 mm *
- B Panel width = min. 250 / max. 600 mm *

* The dimensions depend on the chosen system and mesh pattern

Typical grid layout

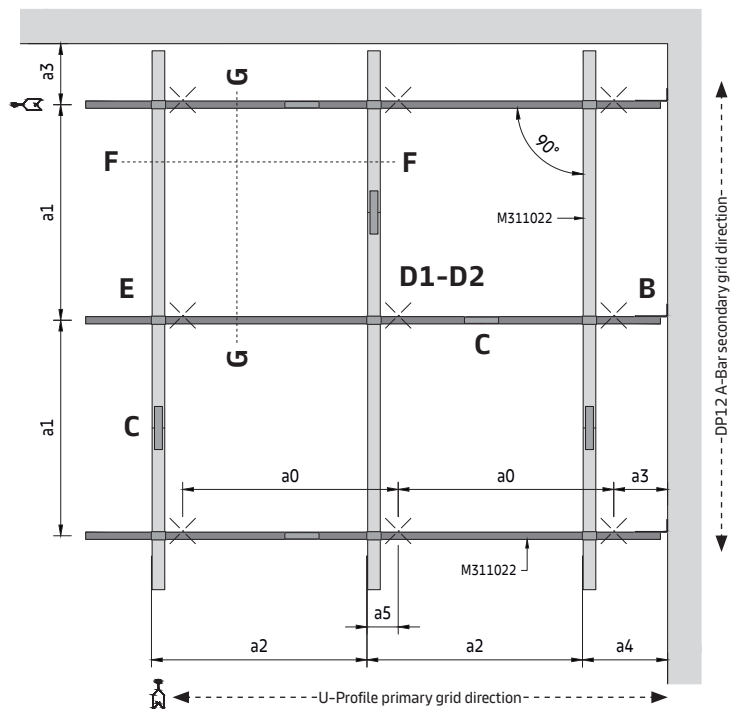

To determine suspension layout

The module length (M) of the requested ceiling is equal to the distance between the DP12 A-Bar centres (a2).

On the appropriate spacing table, read down the column headed (a2) to the required module length then read across to determine the suspension point spacing (a0) and DP12 A-Bar spacing (a1).

The shown values are maximum allowed distances and can be reduced but not exceeded.

MESH R-Clip
D03.100.1

Detail E

Cross Connector installation

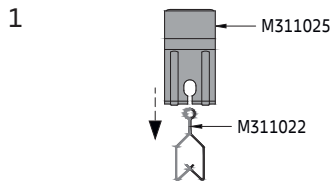

The cross connector is inserted from the end of the DP12 A-Bar secondary grid. Then it can be slid to the correct position.

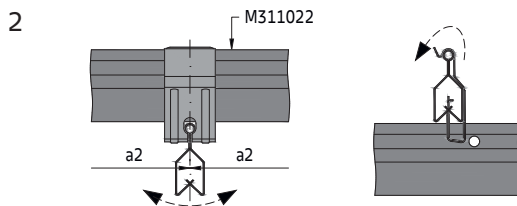

The cross connector for DP12 A-Bar is made of spring steel and is therefore elastic. It is hooked on the DP12 A-Bar primary grid. The DP12 A-Bar secondary grid is now locked in position. Due to the round head of the DP12 A-Bar, it can swing. This is important because it allows any tolerances to be compensated. Otherwise the tiles / panels could no longer be inserted after a certain point.

Detail C

Splice connection

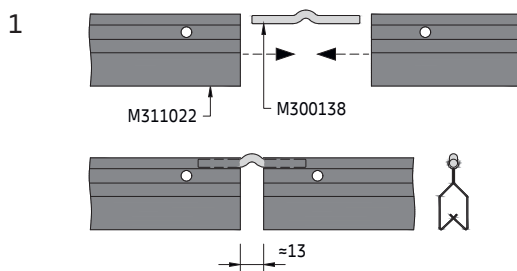

Insert the connection pin at the ends of the DP12 A-Bars and connect them. There is a gap between the DP12 A-Bars. The DP12 A-Bars must be aligned so that the joint is not in the same place as the pips on the tiles / panels.

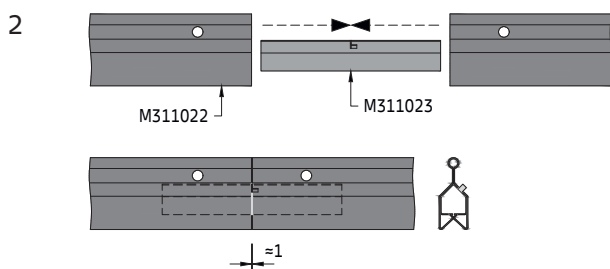

Optionally, the splice connector for DP12 A-Bar can be used. This is inserted at the ends of the DP12 A-Bars and an almost seamless connection is created.

MESH R-Clip
D03.100.1

Detail I

Panel insertion

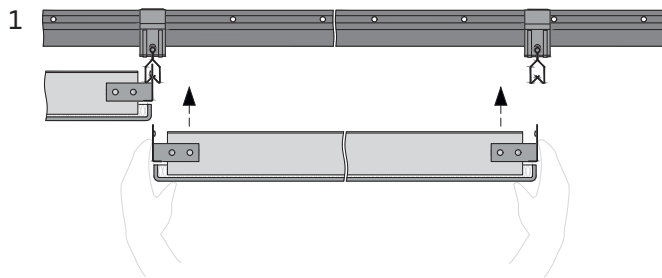

Take the panel and carefully insert it into the DP12 A-Bars from below. Care is required when installing panels. Always press along the edges with the pips and never on the transverse sides, otherwise the panel may be damaged.

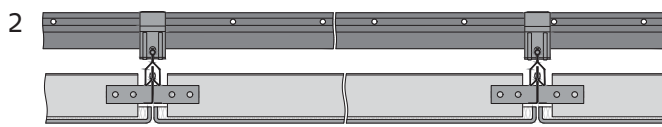

The panels are correctly inserted when all four corners are flush with the neighbouring panels. The panels are designed to match the DP12 A-Bar. If third party profiles are used there is a high probability the tiles will not be correctly inserted.

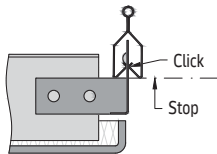

Panel extraction

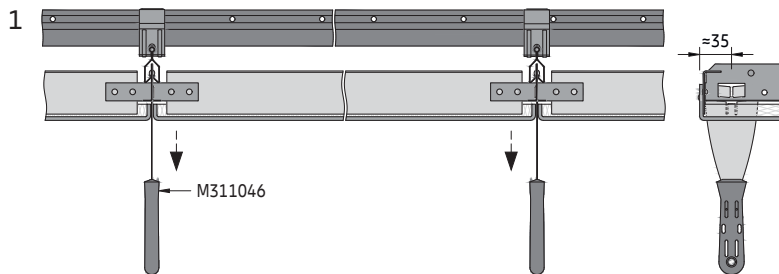

The panels are designed in such a way that the extraction tool can only be inserted in the designated places so that it clicks into place. There are two rectangular cut-outs on the short side of the panels. It is therefore important that the appropriate extraction tool is used. This prevents damage to the panels. Insert on one side first and pull down with a gentle tug, followed by the opposite side.

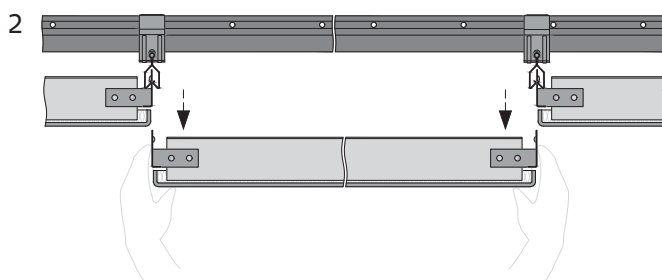

Remove it downwards and store the panel in a safe place so that it cannot be damaged.

MESH R-Clip
D03.100.1

Detail J

Optional security clip

The security clip serves to secure the panels and prevents them from being removed.

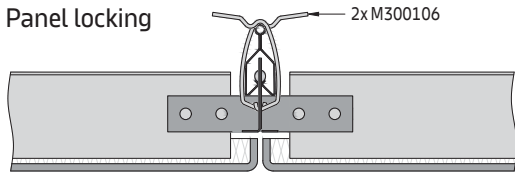

The panels have, on the sides where the pins are, a hole where the security clip can be fixed. First hook the security clip into the panel and then slip the upper end over the DP12 A-Bar. Two security clips are required per panel.

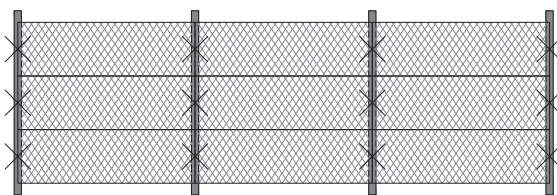

Either individual panels or the entire ceiling can be secured. The panels are inserted and secured immediately. The last panel cannot be locked.

Section L

Staggered layout option (example with suspension option D2)

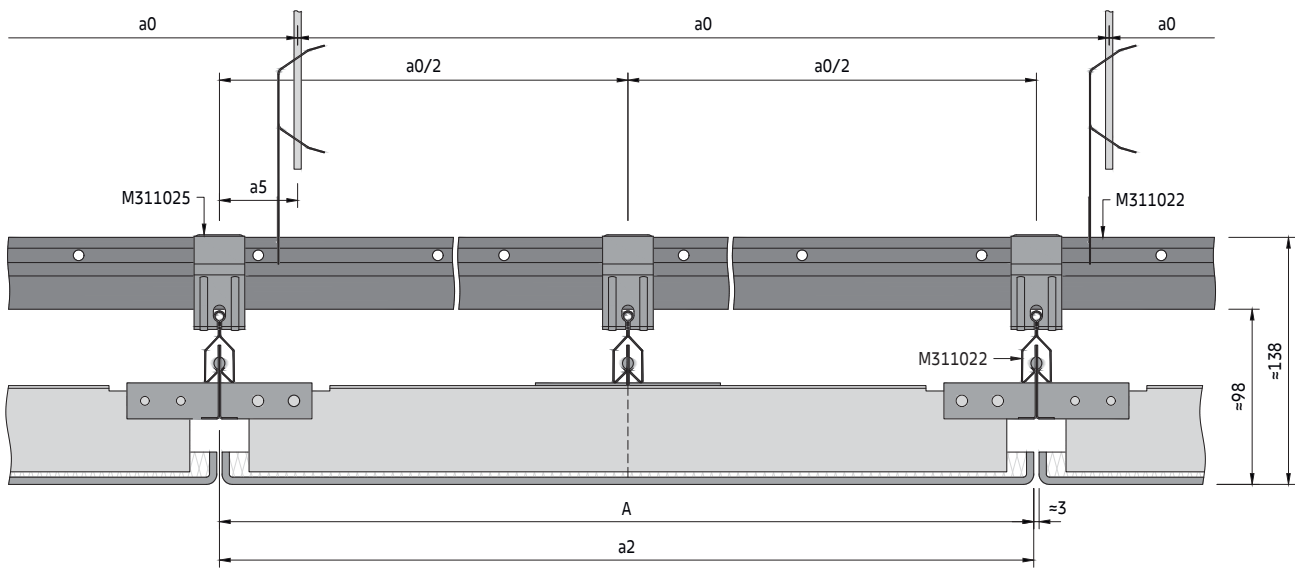

Material required per m² (no waste included)

System without additional load [pcs/m²]

Components		a2 [mm]	1200	1500	1800	2000	2500
M300138	Connection pin for DP12 A-Bar		0.37	0.36	0.44	0.31	0.30
M311022	DP12 A-Bar		0.37	0.35	0.43	0.31	0.29
M311024	Wall anchor for DP12 A-Bar		0.07	0.08	0.12	0.08	0.08
M311025	Cross connector for DP12 A-Bar		0.53	0.50	0.66	0.36	0.31
Various	Suspension points (D1 - D2)		1.22	0.50	0.66	0.72	0.62

The shown quantities are theoretical and based on an ideal layout, without considering the actual room layout. The ideal layout is based on a calculation of 10 x 10 m (100 m²). This calculation does not allow any damage, spare nor wastage. The final quantities and type of suspension have to be checked before ordering. Soffit and wall fixings by others. Not including perimeter trims, optional security clips, extraction tools and swing-down brackets.

MESH R-Clip

Direct suspended DP12 A-Bar
Concealed grid solution for indoor applications

General information

- Concealed clip-in grid system for small areas with low cavity
- DP12 A-Bar made of galvanised steel
- Typical ceiling weight 8.0 - 10.0 kg/m² (indicative value for panels, without additional load)
- Panels are easily installed and fully demountable
- Optional security clips available
- Staggered layout option

Isometric view

Perimeter solutions on separate datasheet.

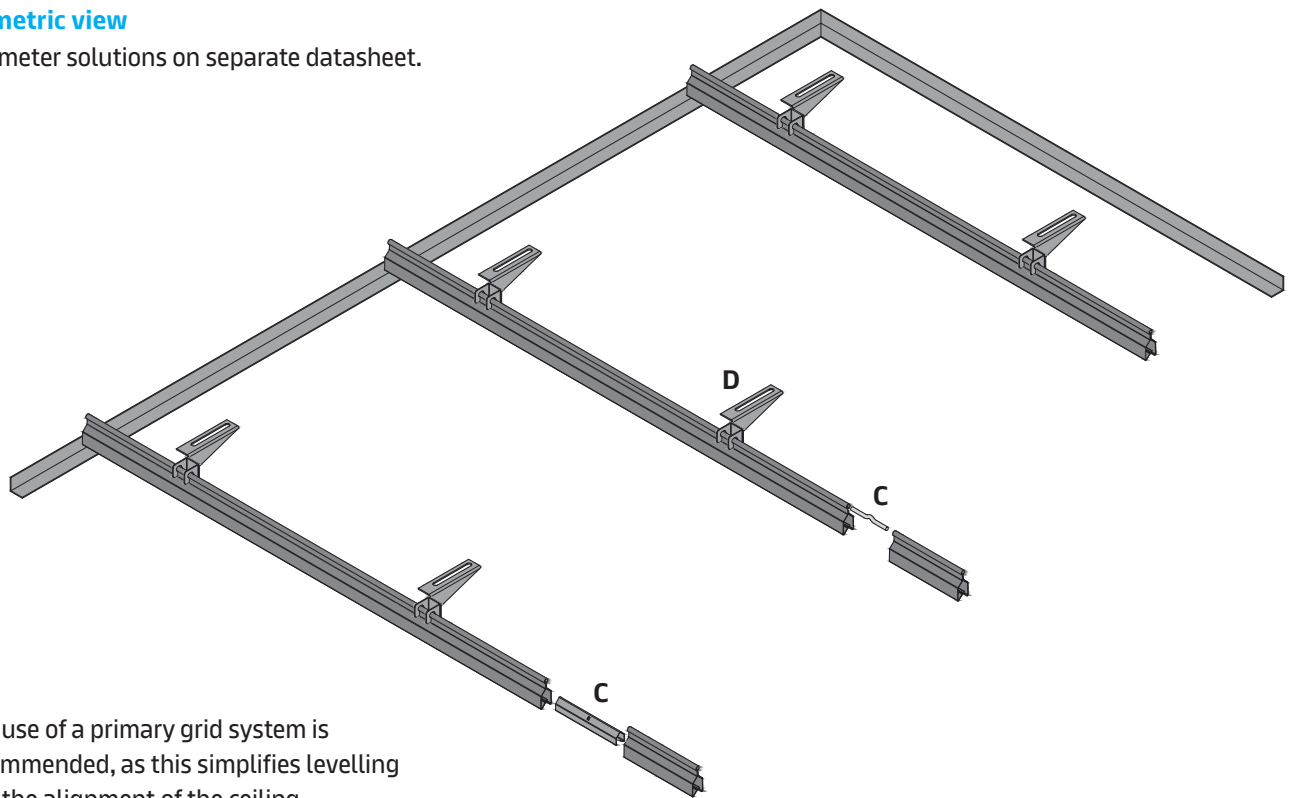

The use of a primary grid system is recommended, as this simplifies levelling and the alignment of the ceiling.

Vario Design layout options

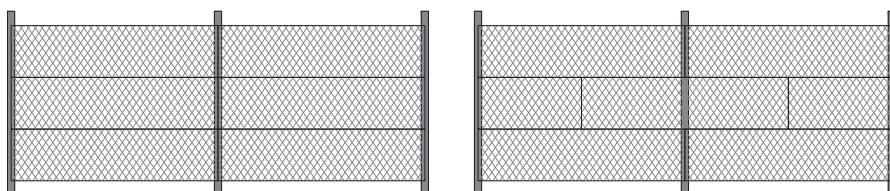

Section A

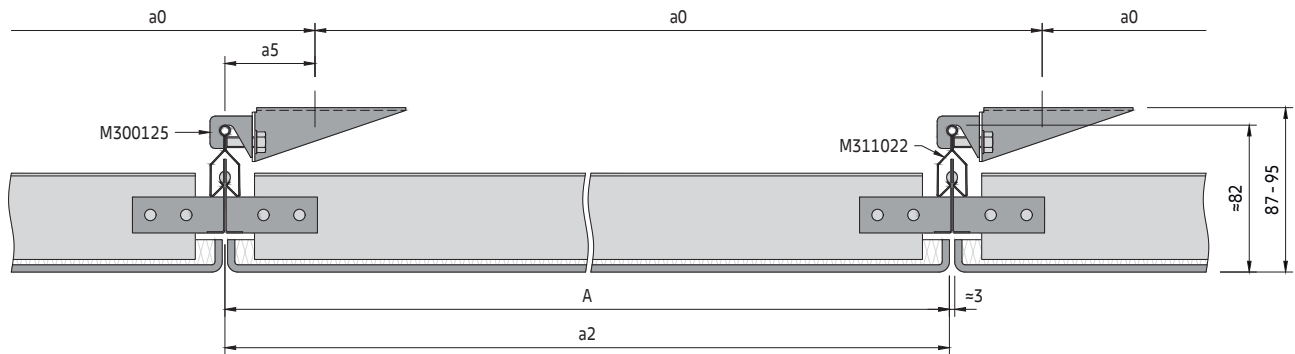

Section B

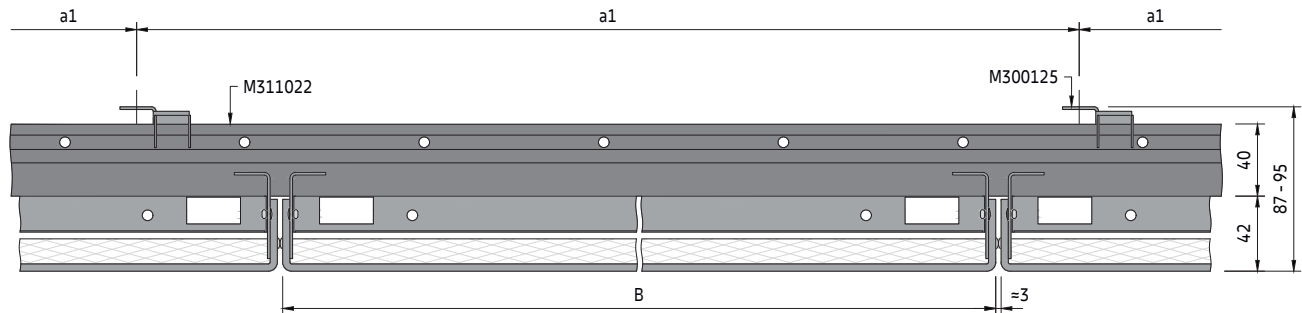

The panels should be installed with a ≈ 3 mm open gap on the long side, which enables installation.

Secondary grid components

Standard components:

- M311022 DP12 A-Bar
- M300138 Connection pin for DP12 A-Bar
- M300125 Direct hanger for DP12 A-Bar

Optional components

- M300106 Security clip
- M311023 Splice connector for DP12 A-Bar
- M311046 Extraction tool

DP12 A-Bar

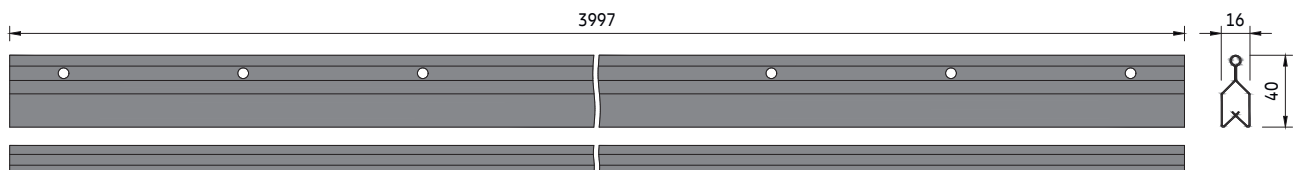

Spacing

a2 [mm]	System without additional load		System with additional load +4 kg/m ²	
	a0 [mm]	a1 [mm]	a0 [mm]	a1 [mm]
600	600	1500	600	1200
650	650	1500	650	1200
700	700	1500	700	1200
750	750	1500	750	1200
800	800	1500	800	1200
850	850	1500	850	1200
900	900	1200	900	1200
950	950	1200	950	1200
1000	1000	1200	1000	1200
1050	1050	1200	1050	1000
1100	1100	1200	1100	1000
1150	1150	1200	1150	1000
1200	1200	1200	1200	1000
1250	1250	1200	1250	1000
1300	1300	1200	1300	1000
1350	1350	1200	1350	900
1400	1400	1000	1400	900
1450	1450	1000	1450	900
1500	1500	1000	1500	900
1550	1550	1000	1550	900
1600	1600	1000	1600	850
1650	1650	1000	1650	800
1700	1700	900	1700	700
1750	1750	850	1750	600
1800	1800	700	1800	600
1850	1850	700	1850	600
1900	1900	650	1900	600
1950	1950	600	1950	600
2000	2000	600	2000	600
2050	2050	600	2050	600
2100	2100	600	2100	600
2150	2150	600	2150	600
2200	2200	600	2200	600
2250	2250	600	2250	600
2300	2300	600	2300	600
2350	2350	600	2350	600
2400	2400	600	2400	600
2450	2450	600	2450	600
2500	2500	600	2500	600

Parameters

- a0 Distance between DP12 A-Bar suspension points
- a1 Max. distance between DP12 A-Bars
- a2 Distance between DP12 A-Bars = panel length + ≈3 mm gap
- a3 Distance from wall = max. 200 mm
- a4 Distance from wall = max. panel length
- a5 Distance between DP12 A-Bar and top fixing = 38 - 50 mm
- M Module size = panel length + ≈3 mm gap / panel width + ≈3 mm gap
- A Panel length = min. 600 / max. 2500 mm *
- B Panel width = min. 250 / max. 600 mm *

* The dimensions depend on the chosen system and mesh pattern

Typical grid layout

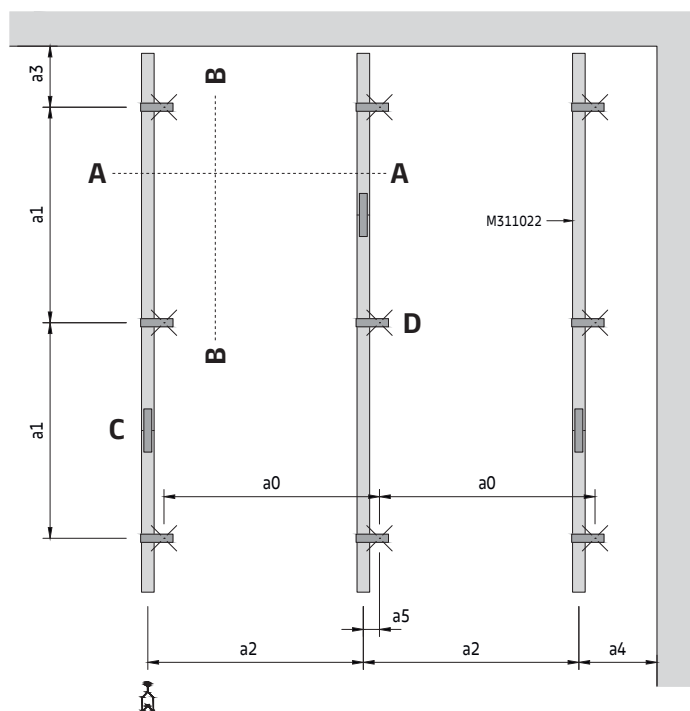

To determine suspension layout

The module length (M) of the requested ceiling is equal to the distance between the DP12 A-Bar centres (a2).

On the appropriate spacing table, read down the column headed (a2) to the required module length then read across to determine the suspension point spacing (a0) and direct hanger spacing (a1).

The shown values are maximum allowed distances and can be reduced but not exceeded.

MESH R-Clip
D03.100.2

Detail C

Splice connection

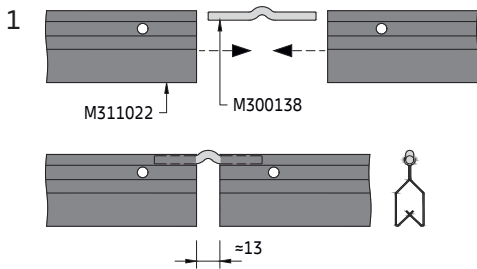

Insert the connection pin at the ends of the DP12 A-Bars and connect them. There is a gap between the DP12 A-Bars. The DP12 A-Bars must be aligned so that the joint is not in the same place as the pips on the tiles / panels.

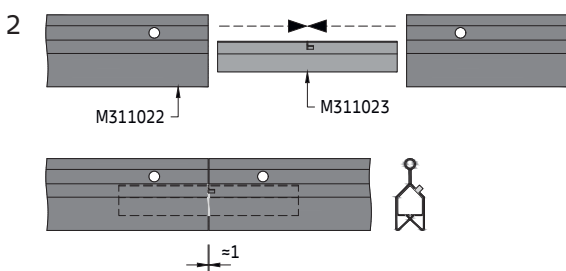

Optionally, the splice connector for DP12 A-Bar can be used. This is inserted at the ends of the DP12 A-Bars and an almost seamless connection is created.

Detail D

Direct hanger installation

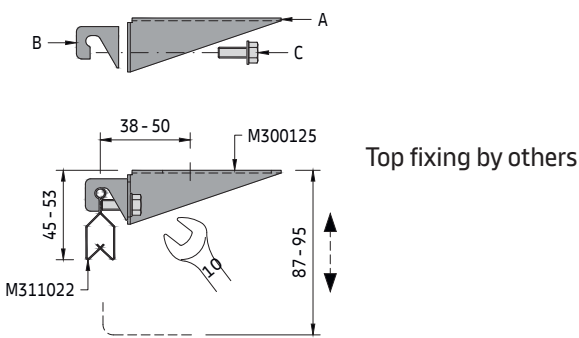

The direct hanger consists of three pre-assembled components (A, B, C).

Part A is attached to the soffit first. The distance from the DP12 A-Bar to the attachment point must not exceed 50mm.

Part B is not tightened, so the DP12 A-Bar can be inserted from below. Tightening the bolt (part C) creates a stable connection. Before that, the height should be set up.

Optional installation

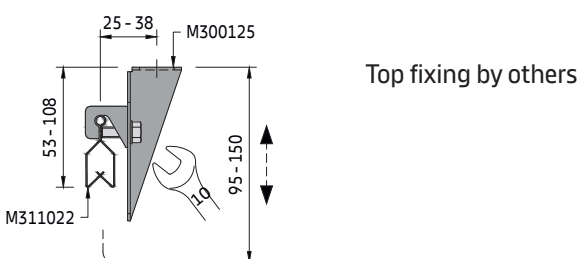

The distance between the DP12 A-Bars should be measured exactly, otherwise the tiles / panels are difficult to install and elements could fall out.

The direct hanger can optionally also be installed vertically. To do this, the components must first be disassembled. The shorter side of part A is then attached to the soffit.

In the staggered layout, the height is an additional 15 mm.

MESH R-Clip
D03.100.2

Detail E

Panel insertion

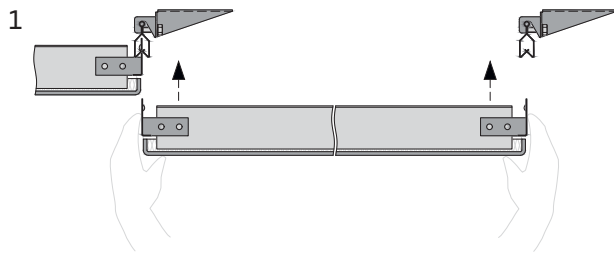

Take the panel and carefully insert it into the DP12 A-Bars from below. Care is required when installing panels. Always press along the edges with the pips and never on the transverse sides, otherwise the panel may be damaged.

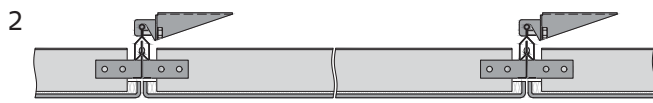

The panels are correctly inserted when all four corners are flush with the neighbouring panels. The panels are designed to match the DP12 A-Bar. If third party profiles are used there is a high probability the tiles will not be correctly inserted.

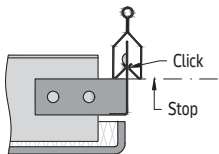

Panel extraction

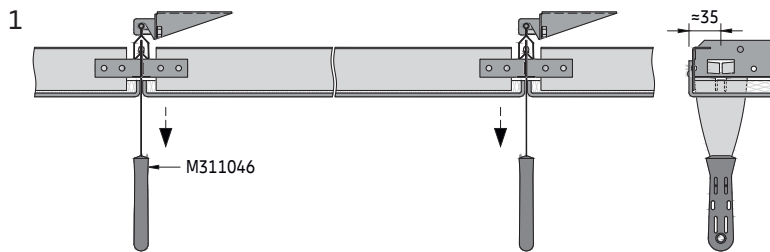

The panels are designed in such a way that the extraction tool can only be inserted in the designated places so that it clicks into place. There are two rectangular cut-outs on the short side of the panels. It is therefore important that the appropriate extraction tool is used. This prevents damage to the panels. Insert on one side first and pull down with a gentle tug, followed by the opposite side.

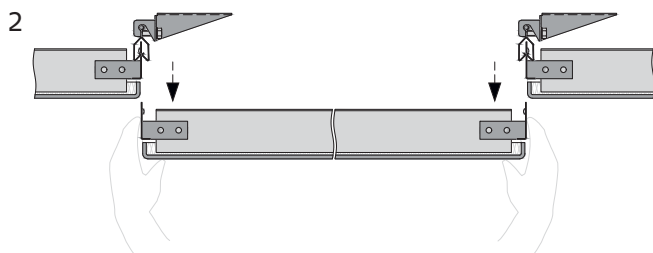

Remove it downwards and store the panel in a safe place so that it cannot be damaged.

MESH R-Clip
D03.100.2

Detail F

Optional security clip

The security clip serves to secure the panels and prevents them from being removed.

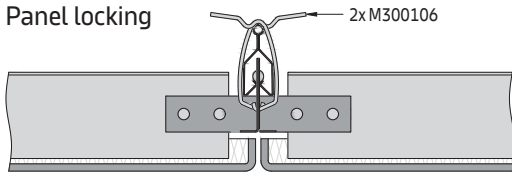

The panels have, on the sides where the pips are, a hole where the security clip can be fixed. First hook the security clip into the panel and then slip the upper end over the DP12 A-Bar. Two security clips are required per panel.

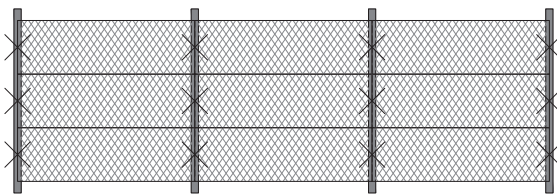

Due to the small distance to the soffit, installing the security clips could be more difficult.

Either individual panels or the entire ceiling can be secured. The panels are inserted and secured immediately. The last panel cannot be locked.

Section G

Staggered layout option

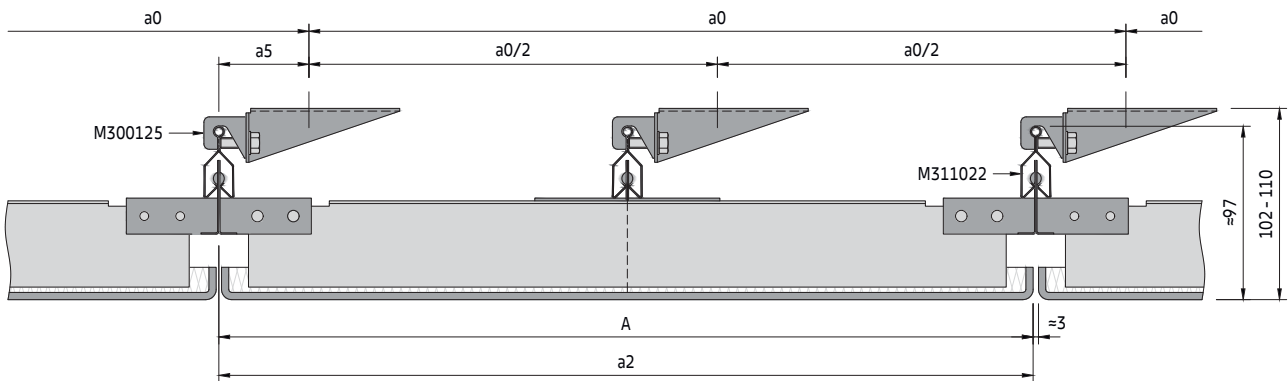

Material required per m² (no waste included)

System without additional load [pcs/m²]

Components	a2 [mm]	1200	1500	1800	2000	2500
M300125	Direct hanger for DP12 A-Bar	0.69	0.67	0.79	0.83	0.67
M300138	Connection pin for DP12 A-Bar	0.21	0.17	0.14	0.13	0.10
M311022	DP12 A-Bar	0.21	0.17	0.14	0.13	0.10

The shown quantities are theoretical and based on an ideal layout, without considering the actual room layout. The ideal layout is based on a calculation of 10 x 10 m (100 m²). This calculation does not allow any damage, spare nor wastage. The final quantities and type of suspension have to be checked before ordering. Soffit and wall fixings by others. Not including perimeter trims, optional security clips, extraction tools and swing-down brackets.

MESH R-H 200 / MESH R-H 200 MT

U-Profile primary grid + J-Bar secondary grid
Concealed grid solution for indoor applications

General information

- Concealed hook-on grid system for medium and large rooms
- For perpendicular installation on U-Profile primary grid
- J-Bar made of galvanised steel
- Typical ceiling weight 8.5 - 10.0 kg/m² (indicative value for panels, without additional load)
- Panels are easily installed and fully demountable
- Security option available
- Long side suspension option
- MESH R-H 200 MT Megapanel option (up to 1200 x 1202 mm)

Isometric view

Select the suspension option E1 - E4.
Perimeter solutions on separate datasheet.

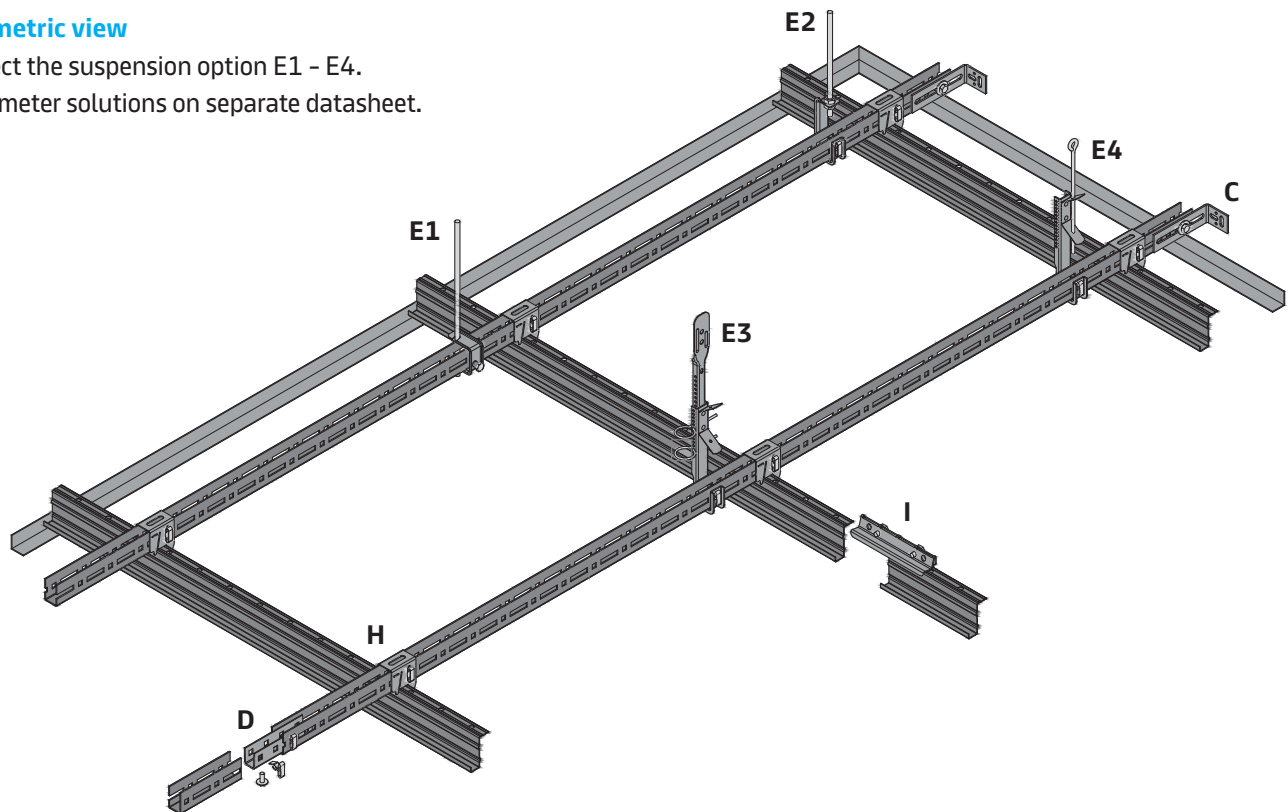

Vario Design & bespoke layout options

Vario Design

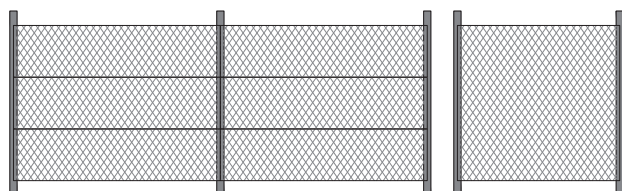

Bespoke (on request)

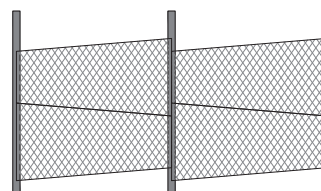

MESH R-H 200 / MESH R-H 200 MT
D03.101

Section F (MESH R-H 200)

Example with primary angle 27 x 22 mm

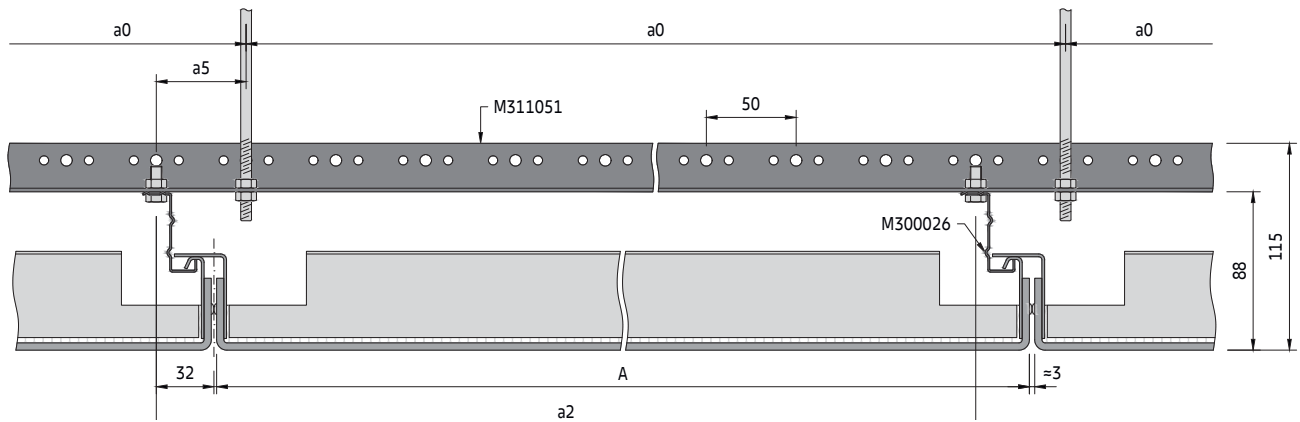

The panels should be installed with a ≈3 mm open gap on the short side, which enables installation.

Section F (MESH R-H 200 MT)

Example with primary angle 27 x 22 mm

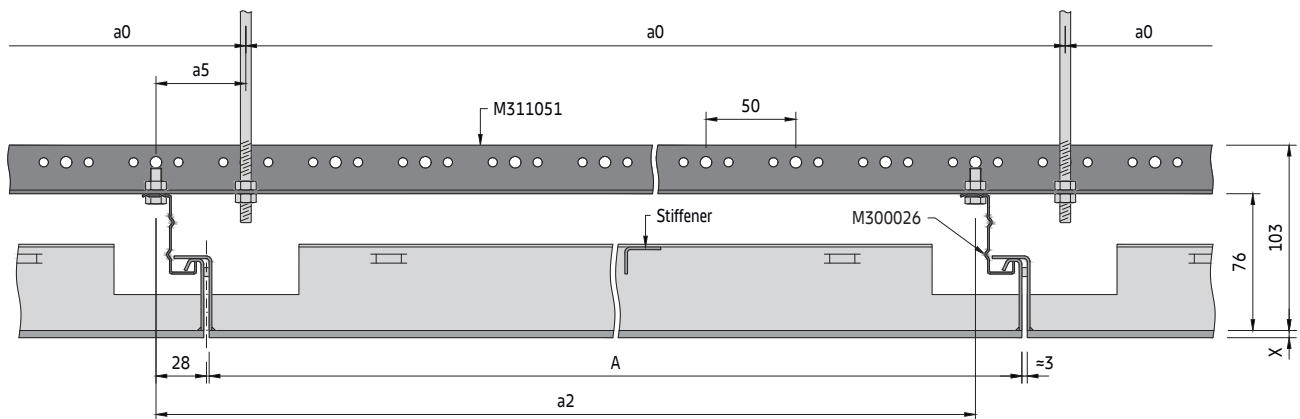

The panels come standard with a ≈3 mm spacer on the short side. Panels >2000 mm length with additional welded stiffener.

Secondary grid components

Standard components:

- M300026 J-Bar
- M300343 Splice connector for J-Bar

Optional components

- M311218 Security bracket (screwed option)
- M311191 Self-drilling screw 3.5 x 9.5 mm

See primary angle primary grid for primary grid components

J-Bar secondary grid

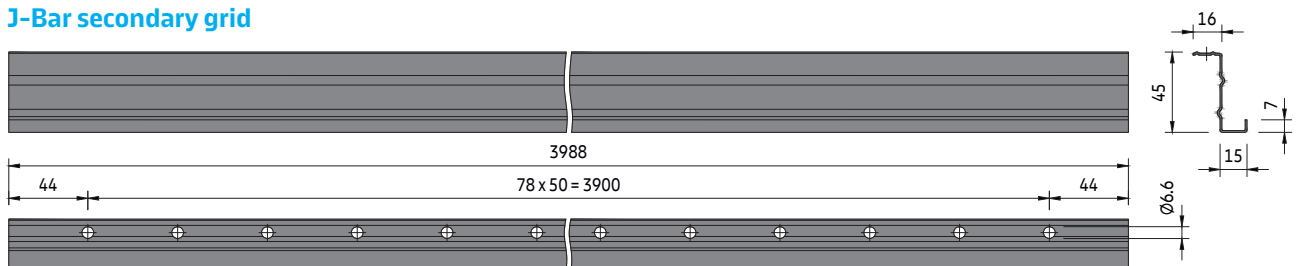

MESH R-H 200 / MESH R-H 200 MT
D03.101

Section G (MESH R-H 200)

Example with suspension option E1

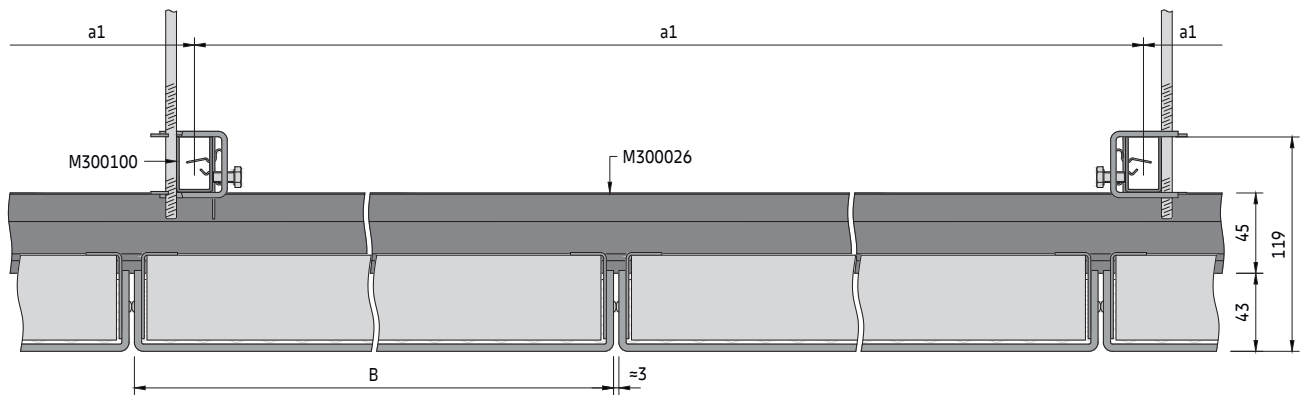

The panels should be installed with a ≈ 3 mm open gap on the long side, which enables installation.

Section G (MESH R-H 200 MT)

Example with suspension option E1

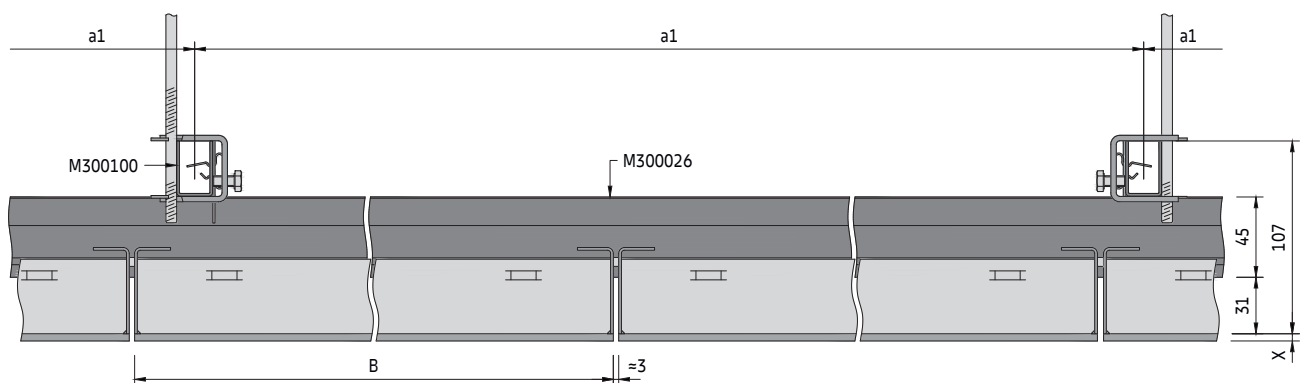

The panels come standard with a ≈ 3 mm spacer on the long side.

MESH R-H 200 / MESH R-H 200 MT

D03.101

Spacing

a2 [mm]	System without additional load		System with additional load +4 kg/m ²	
	a0 [mm]	a1 [mm]	a0 [mm]	a1 [mm]
600	1200	1200	1200	1150
650	1300	1300	1300	1000
700	1400	1150	700	1750
750	750	1750	750	1650
800	800	1700	800	1600
850	850	1650	850	1550
900	900	1600	900	1500
950	950	1550	950	1450
1000	1000	1550	1000	1450
1050	1050	1500	1050	1400
1100	1100	1450	1100	1350
1150	1150	1450	1150	1350
1200	1200	1400	1200	1300
1250	1250	1400	1250	1200
1300	1300	1150	1300	1100
1350	1350	1150	1350	1050
1400	1400	1150	1400	950
1450	1450	1150	1450	900
1500	1500	1100	1500	800
1550	1550	1050	1550	750
1600	1600	1000	1600	700
1650	1650	950	1650	700
1700	1700	850	1700	650
1750	1750	800	1750	600
1800	1800	750	1800	550
1850	925	1150	925	1050
1900	950	1150	950	1050
1950	975	1150	975	1050
2000	1000	1100	1000	1050
2050	1025	1100	1025	1000
2100	1050	1100	1050	1000
2150	1075	1100	1075	1000
2200	1100	1050	1100	1000
2250	1125	1050	1125	950
2300	1150	1050	1150	950
2350	1175	1050	1175	950
2400	1200	1000	1200	950
2450	1225	1000	1225	950
2500	1250	1000	1250	900

Parameters

- a0 Distance between U-Profile suspension points = max. 1900 mm
- a1 Max. distance between U-Profiles
- a2 Distance between J-Bars = panel length + ≈3 mm gap
- a3 Distance from wall = max. 200 mm
- a4 Distance from wall = max. panel length
- a5 Distance from U-Profile suspension point to hanger = max. 100 mm
- M Module size = panel length + ≈3 mm gap / panel width + ≈3 mm gap
- A Panel length = min. 597 / max. 2500 mm *
- B Panel width = min. 247 / max. 700 mm *
- X Mesh thickness

* The dimensions depend on the chosen system and mesh pattern

Typical grid layout

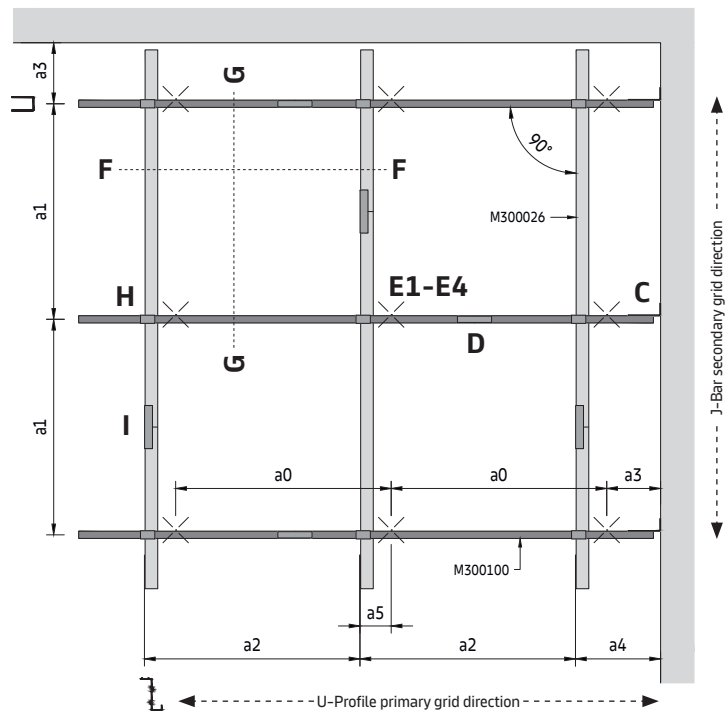

To determine suspension layout

The module length (M) of the requested ceiling is equal to the distance between the J-Bar centres (a2).

On the appropriate spacing table, read down the column headed (a2) to the required module length then read across to determine the suspension point spacing (a0) and U-Profile spacing (a1).

The shown values are maximum allowed distances and can be reduced but not exceeded.

MESH R-H 200 / MESH R-H 200 MT
D03.101

Detail H

Hanger installation

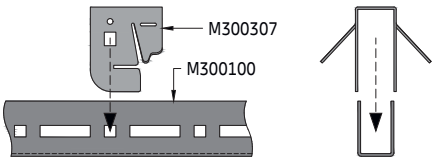
- 1 

Place the hanger on the U-profile.

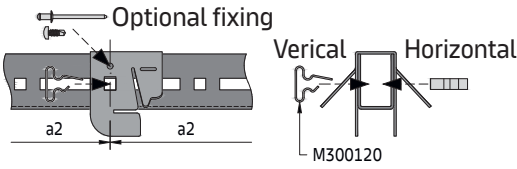
- 2 

Fix hanger with plug-in clips at the specified module spacing (inserted vertically or horizontally). If the panel size does not fit with the modulation of the U-Profile (25 mm increments), the plug-in clip needs to be inserted into a long hole. The hanger position can alternatively be fixed by using a pop-riquet or self-drilling screw.

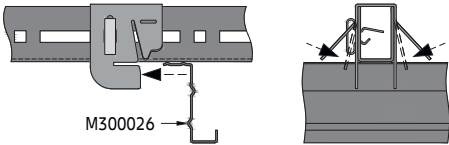
- 3 

Insert the J-Bar into the hanger, press down the two hanger wings to lock the position of the J-Bar.

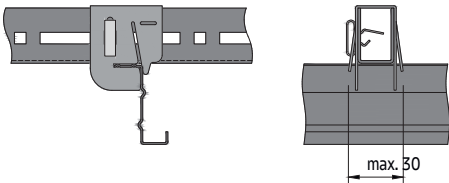
- 4 

The J-Bar is now locked in position.

Detail I

Splice connection

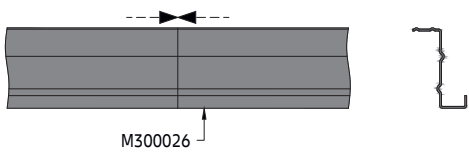
- 1 

Once the J-Bars are installed under the U-Profiles, the ends should be brought together without a gap.

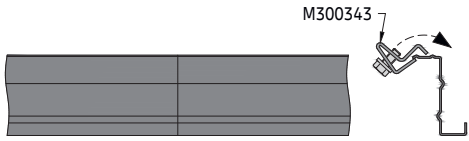
- 2 

The connectors for the J-Bar must be inserted from above.

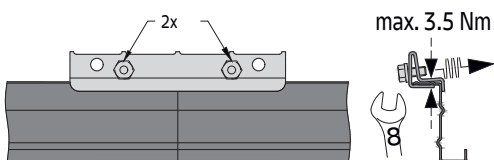
- 3 

Use the bolts to secure the connector. Stagger the joints.

MESH R-H 200 / MESH R-H 200 MT

D03.101

Detail J

Panel insertion (example with MESH R-H 200)

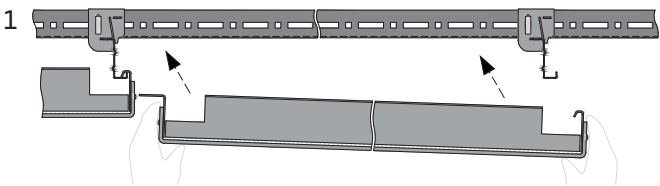
1  First place the panels with the outward bend short side above the neighbour panel to the left.

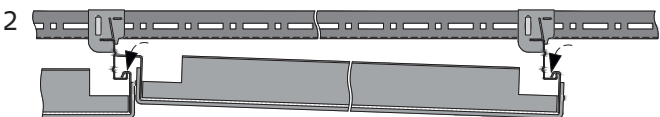
2  Hook-on the opposite side with the hook detail on the J-Bar to the right. The panel will rest now on the neighbour panel to the left and the J-Bar to the right.

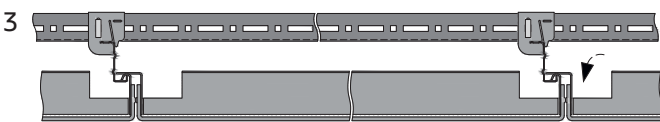
3  Continue with the next panel.

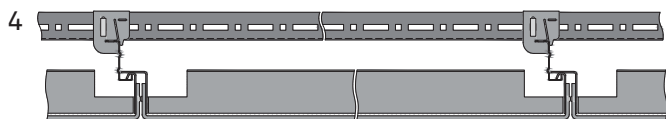

Panel extraction (example with MESH R-H 200)

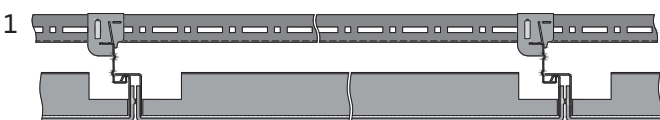
1  With a closed ceiling, any panel can be removed as long as there are no obstacles such as service integrations, etc.

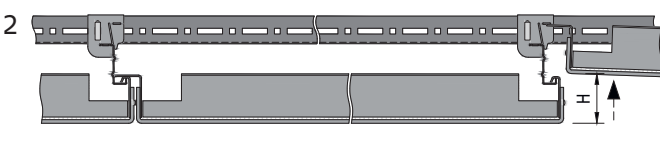
2  Lift the neighbour panel to the right.
 MESH R-H 200: (H) = min. 55 mm
 MESH R-H 200 MT: (H) = min. 52 mm

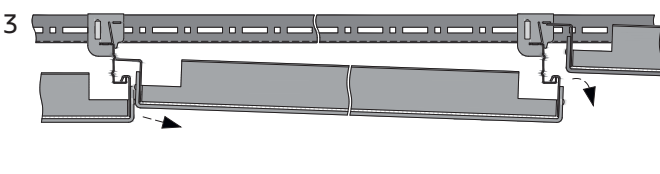
3  Detach the panel that is to be removed from the J-Bar. If the panel is located under a U-Profile, the neighbour panel must first be removed. The panel that is actually to be removed must be slid horizontally so that it is no longer located under the U-Profile. The panel can now be removed.

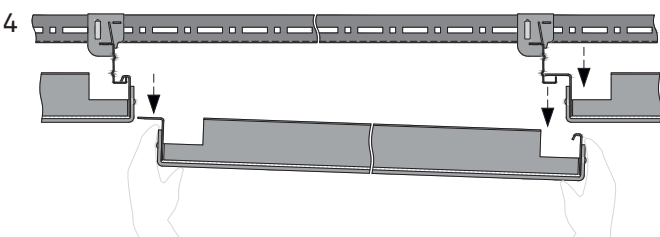
4  Remove it downwards and store the panel in a safe place so that it cannot be damaged. The neighbour panel will rest again on the J-Bar.

MESH R-H 200 / MESH R-H 200 MT
D03.101

Detail K

Optional security bracket (screwed version)

The security bracket serves to secure the panels and prevents them from being removed.

Panel installation / locking (example with MESH R-H 200)

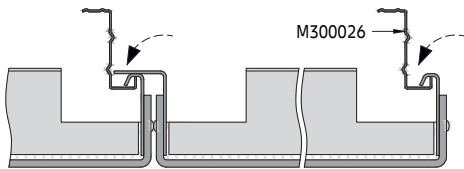
1  When using the screwed optional security bracket, panel by panel is installed and secured immediately.

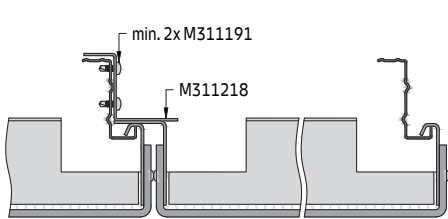
2  The bracket is placed at the crossing point between the panels. There are two options (A / B) of how the security bracket can be installed. Use at minimum 2 self-drilling screws to fix it. One security bracket per panel is needed.

3 **Option A** **Option B**  Follow this row by row, until the ceiling is completely installed and locked. The last panel remains unsecured. If panels are to be removed, the ceiling must be opened from the last panel to the desired area.

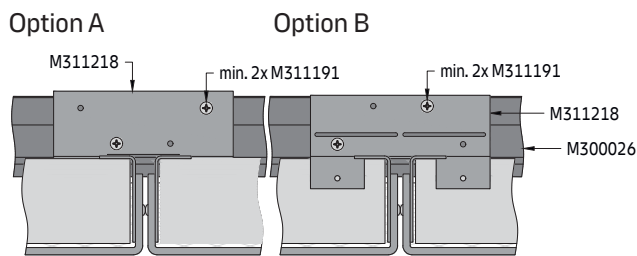

Front side view

Locked position

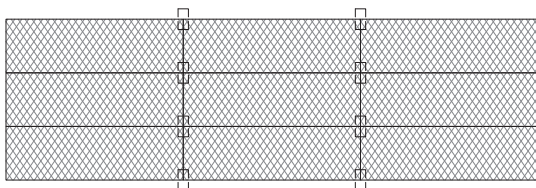

MESH R-H 200 / MESH R-H 200 MT

D03.101

Material required per m² (no waste included)

System without additional load [pcs/m²]

Components	a2 [mm]	1200	1600	1800	2000	2200	2500
M300026	J-Bar	0.21	0.16	0.14	0.13	0.12	0.10
M300100	U-Profile	0.19	0.27	0.35	0.24	0.25	0.27
M300119	Splice connector for U-Profile	0.20	0.27	0.36	0.25	0.26	0.27
M300120	Plug-in clip for U-Profile	1.00	1.17	1.47	0.96	0.96	0.94
M300140	Wall anchor	0.08	0.11	0.14	0.10	0.10	0.11
M300307	Hanger for J-Bar	0.6	0.63	0.75	0.46	0.44	0.40
M300343	Splice connector for J-Bar	0.21	0.16	0.14	0.13	0.12	0.11
M311103	Hexagonal nut M6	0.10	0.10	0.10	0.10	0.10	0.10
M311105	Washer	0.10	0.10	0.10	0.10	0.10	0.10
M311303	Hexagonal bolt M6 x 16 mm	0.10	0.10	0.10	0.10	0.10	0.10
Various	Suspension points (E1 - E4)	0.6	0.63	0.75	0.91	0.87	0.80

The shown quantities are theoretical and based on an ideal layout, without considering the actual room layout. The ideal layout is based on a calculation of 10 x 10 m (100 m²). This calculation does not allow any damage, spare nor wastage. The final quantities and type of suspension have to be checked before ordering. Soffit and wall fixings by others. Not including perimeter trims, optional security brackets and extraction tools.

MESH R-H 200 / MESH R-H 200 MT

U-Profile primary grid + J-Bar secondary grid
Concealed grid solution for indoor applications

General information

- Concealed hook-on grid system for medium and large rooms
- For perpendicular or radial installation on primary angle primary grid (27 x 22 / 50 x 22 mm option)
- J-Bar made of galvanised steel
- Typical ceiling weight 8.5 - 10.0 kg/m² (indicative value for panels, without additional load)
- Panels are easily installed and fully demountable
- Security option available
- Long side suspension option
- MESH R-H 200 MT Megapanel option (up to 1200 x 1202 mm)

Isometric view

Example with primary angle 27 x 22 mm
Perimeter solutions on separate datasheet.

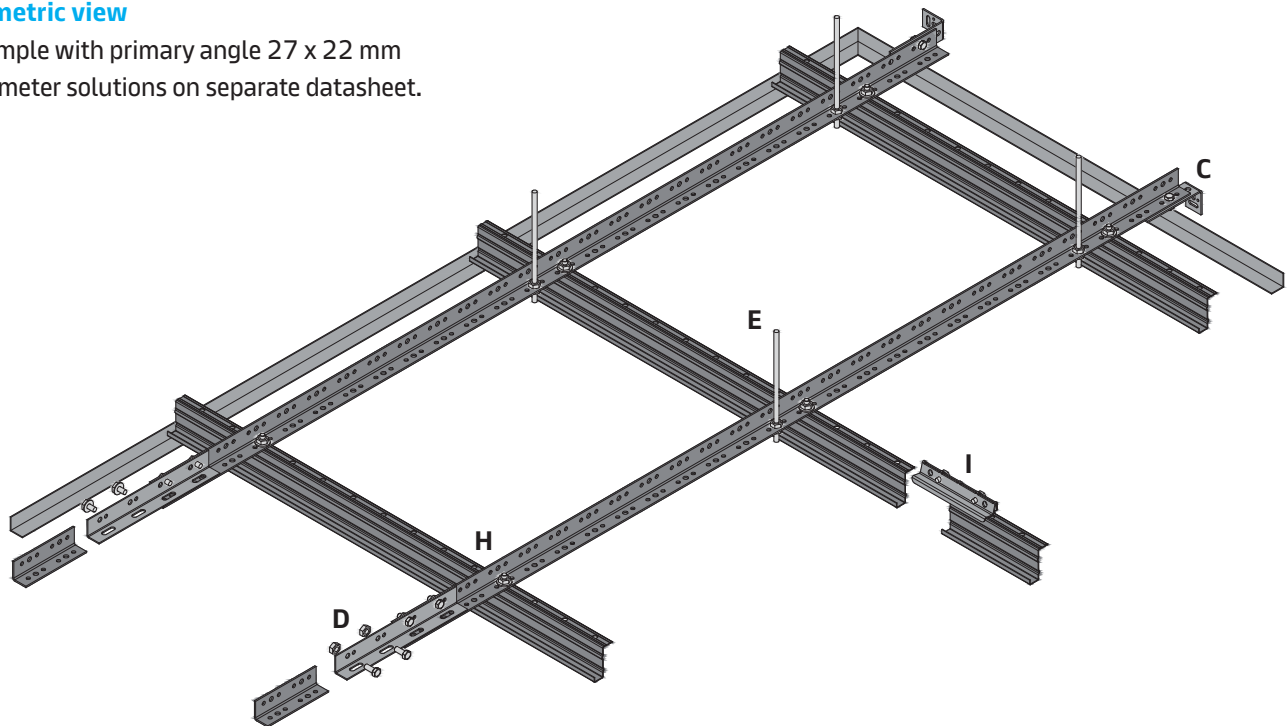

Vario Design & bespoke layout options

Vario Design

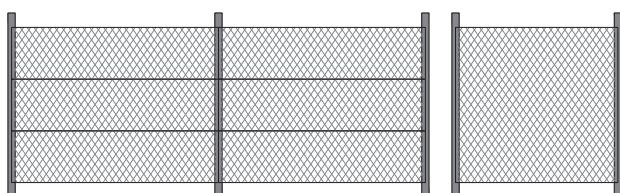

Bespoke (on request)

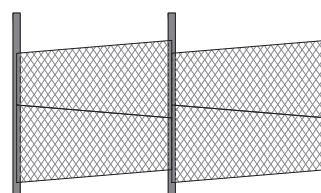

MESH R-H 200 / MESH R-H 200 MT
D03.101.1

Section F (MESH R-H 200)

Example with suspension option E1

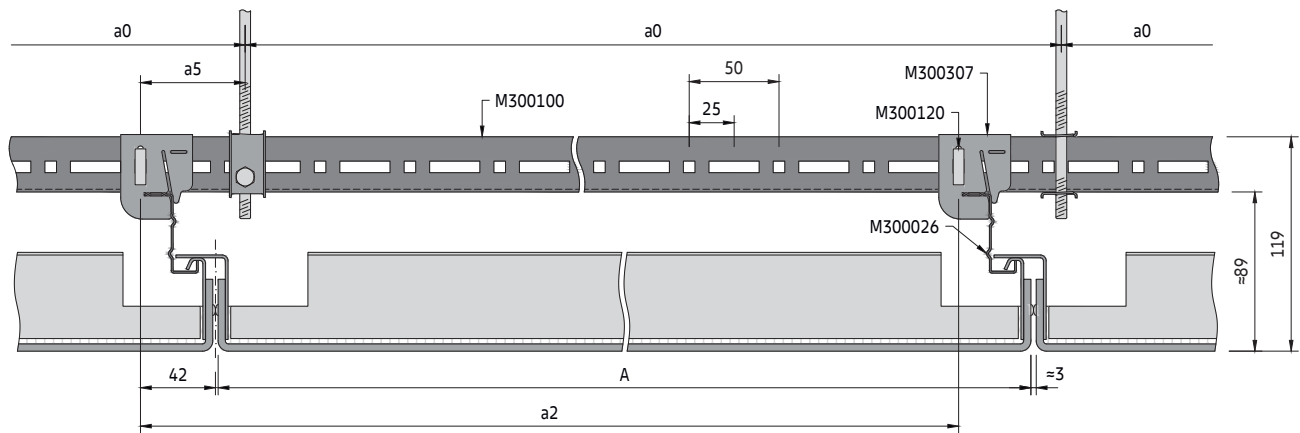

The panels should be installed with a ≈ 3 mm open gap on the short sides, which enables installation.

Section F (MESH R-H 200 MT)

Example with suspension option E1

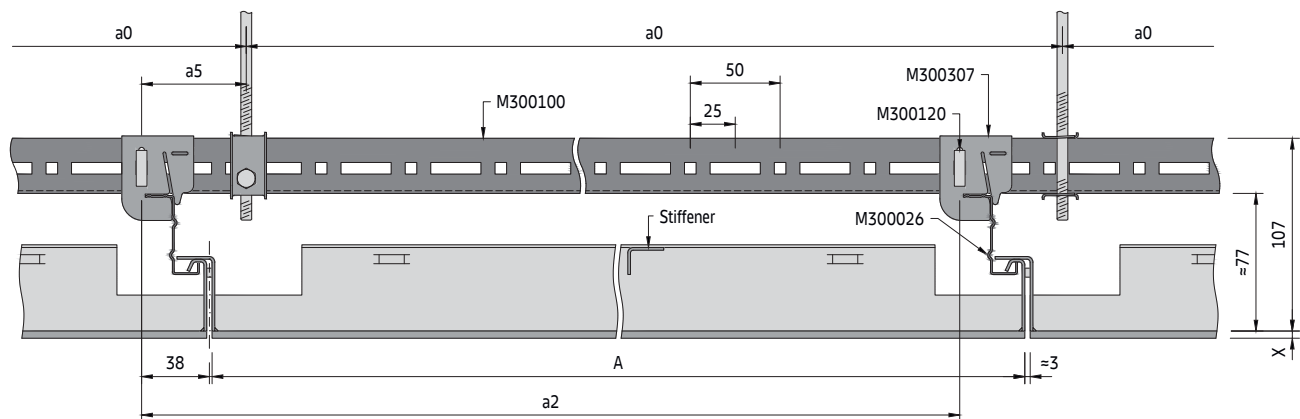

The panels come standard with a ≈ 3 mm spacer on the short sides. Panels >2000 mm length with additional welded stiffener.

Secondary grid components

Standard components:

- M300026 J-Bar
- M300343 Splice connector for J-Bar
- M300307 Hanger for J-Bar
- M300120 Plug-in clip for U-Profile

Optional components

- M311218 Security bracket (screwed option)
- M311191 Self-drilling screw 3.5 x 9.5 mm

See U-Profile primary grid for primary grid components

J-Bar secondary grid

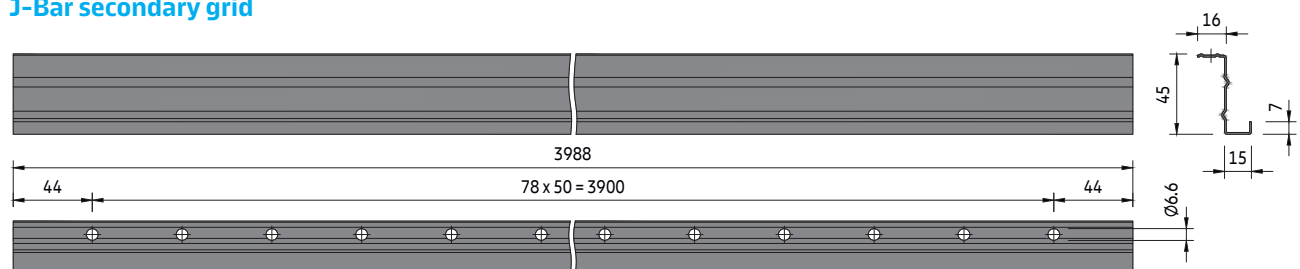

MESH R-H 200 / MESH R-H 200 MT
D03.101.1

Section G (MESH R-H 200)

Example with primary angle 27 x 22 and 50 x 22 mm

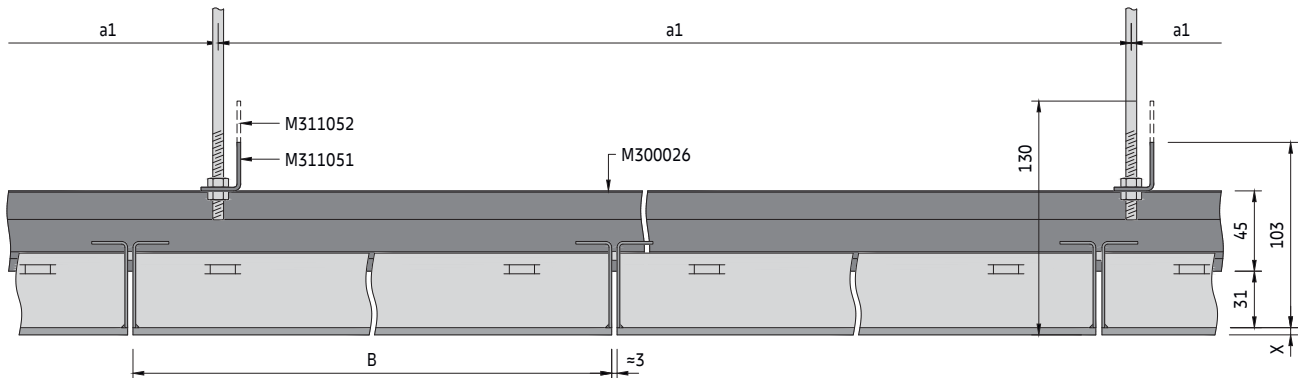

The panels should be installed with a ≈ 3 mm open gap on the long side, which enables installation.

Section G (MESH R-H 200 MT)

Example with primary angle 27 x 22 and 50 x 22 mm

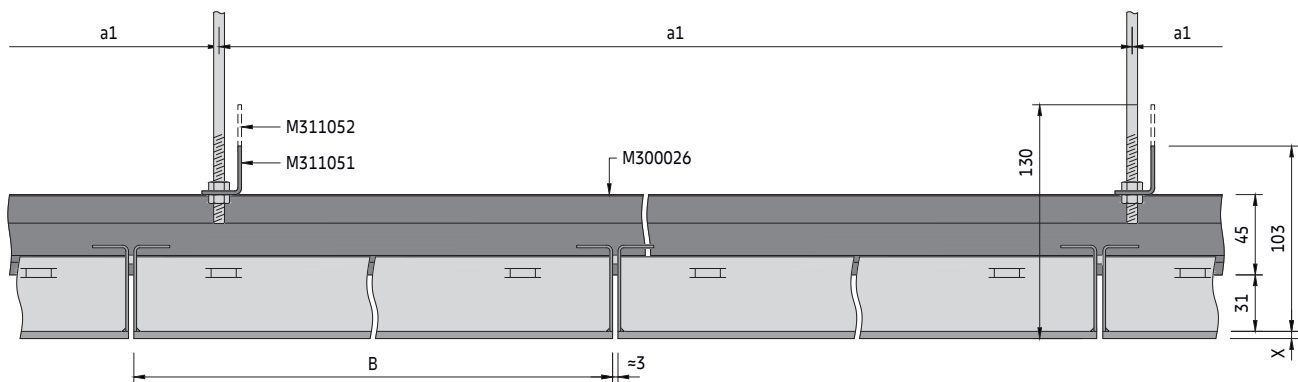

The panels come standard with a ≈ 3 mm spacer on the long side.

Detail H

J-Bar fixing

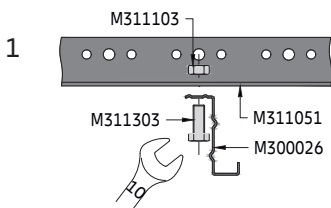

Use an M6 bolt and nut to screw the J-Bar below the primary angle.

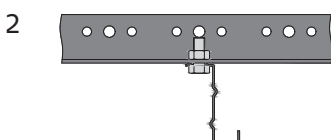

The J-Bar is now fixed.

Detail I

Splice connection

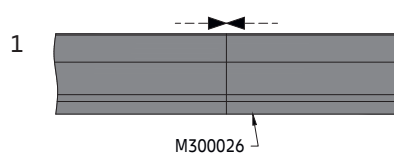

Once the J-Bars are installed under the U-Profiles, the ends should be brought together without a gap.



The connectors for the J-Bars must be inserted from above.

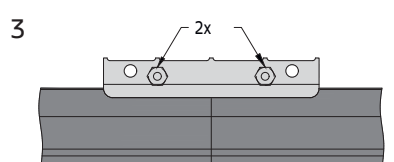

Use the bolts to secure the connector. Stagger the joints.

MESH R-H 200 / MESH R-H 200 MT
D03.101.1

Detail J

Panel insertion (example with MESH R-H 200)

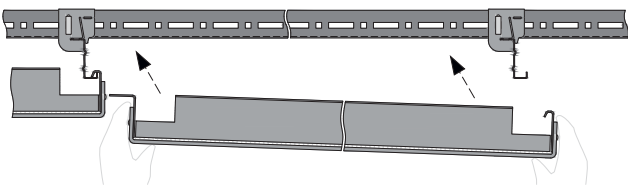
1  First place the panels with the outward bend short side above the neighbour panel to the left.

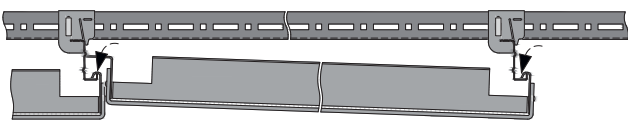
2  Hook-on the opposite side with the hook detail on the J-Bar to the right. The panel will rest now on the neighbour panel to the left and the J-Bar to the right.

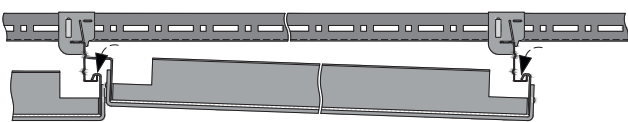
3  Continue with the next panel.

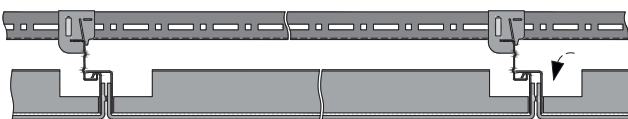
4 

Panel extraction (example with MESH R-H 200)

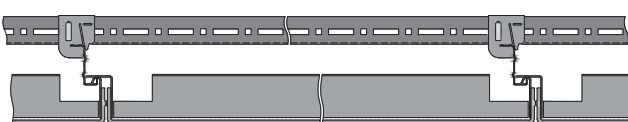
1  With a closed ceiling, any panel can be removed as long as there are no obstacles such as service integrations, etc.

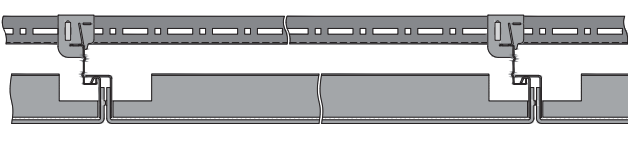
2  Lift the neighbour panel to the right.
MESH R-H 200: (H) = min. 55 mm
MESH R-H 200 MT: (H) = min. 52 mm

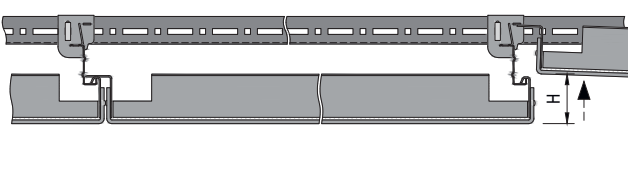
3  Detach the panel that is to be removed from the J-Bar. If the panel is located under a primary angle, the neighbour panel must first be removed. The panel that is actually to be removed must be slid horizontally so that it is no longer located under the primary angle. The panel can now be removed.

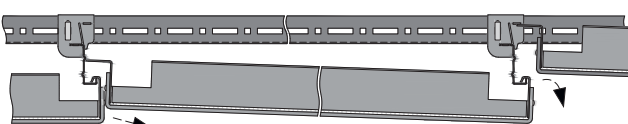
4  Remove it downwards and store the panel in a safe place so that it cannot be damaged. The neighbour panel will rest again on the J-Bar.

MESH R-H 200 / MESH R-H 200 MT

D03.101.1

Spacing for primary angle 27 x 22 mm

a2 [mm]	System without additional load		System with additional load +4 kg/m ²	
	a0 [mm]	a1 [mm]	a0 [mm]	a1 [mm]
600	1200	1200	1200	1000
650	1300	1200	1300	750
700	1400	1000	700	1500
750	750	1500	750	1500
800	800	1500	800	1500
850	850	1500	850	1200
900	900	1500	900	1200
950	950	1200	950	1200
1000	1000	1200	1000	1200
1050	1050	1200	1050	1200
1100	1100	1200	1100	1200
1150	1150	1200	1150	1200
1200	1200	1200	1200	1200
1250	1250	1200	1250	1000
1300	1300	1000	1300	1000
1350	1350	1000	1350	750
1400	1400	1000	1400	750
1450	1450	1000	1450	750
1500	1500	1000	1500	750
1550	1550	750	1550	600
1600	1600	750	1600	600
1650	1650	750	1650	600
1700	1700	750	1700	500
1750	1750	600	1750	500
1800	1800	600	1800	500
1850	925	1000	925	750
1900	950	1000	925	750
1950	975	1000	975	750
2000	1000	1000	1000	750
2050	1025	1000	1025	750
2100	1050	1000	1050	750
2150	1075	1000	1075	750
2200	1100	750	1100	750
2250	1125	750	1125	750
2300	1150	750	1150	750
2350	1175	750	1175	750
2400	1200	750	1200	750
2450	1225	750	1225	750
2500	1250	750	1250	750

Spacing for primary angle 50 x 22 mm

a2 [mm]	System without additional load		System with additional load +4 kg/m ²	
	a0 [mm]	a1 [mm]	a0 [mm]	a1 [mm]
600	1200	1700	1200	1550
650	1300	1650	1300	1500
700	1400	1600	1400	1450
750	1500	1600	750	1450
800	1600	1550	800	1450
850	1700	1550	850	1400
900	900	1500	900	1400
950	950	1500	950	1350
1000	1000	1450	1000	1350
1050	1050	1450	1050	1300
1100	1100	1400	1100	1300
1150	1150	1400	1150	1300
1200	1200	1400	1200	1250
1250	1250	1400	1250	1250
1300	1300	1350	1300	1250
1350	1350	1350	1350	1250
1400	1400	1350	1400	1200
1450	1450	1350	1450	1200
1500	1500	1300	1500	1200
1550	1550	1300	1550	1200
1600	1600	1300	1600	1150
1650	1650	1300	1650	1150
1700	1700	1250	1700	1150
1750	1750	1250	1750	1150
1800	1800	1250	1800	1150
1850	925	1250	925	1100
1900	950	1250	950	1100
1950	975	1150	975	1100
2000	1000	1150	1000	1100
2050	1025	1150	1025	1100
2100	1050	1150	1050	1050
2150	1075	1150	1075	1050
2200	1100	1150	1100	1050
2250	1125	1150	1125	1050
2300	1150	1150	1150	1050
2350	1175	1150	1175	1050
2400	1200	1150	1200	1050
2450	1225	1150	1225	1000
2500	1250	1150	1250	1000

MESH R-H 200 / MESH R-H 200 MT
D03.101.1

Parameters

- a0 Distance between primary angle suspension points = max. 1900 mm
- a1 Max. distance between primary angles
- a2 Distance between J-Bars = panel length + ≈3 mm gap
- a3 Distance from wall = max. 200 mm
- a4 Distance from wall = max. panel length
- a5 Distance from primary angle suspension point to hanger = max. 100 mm
- M Module size = panel length + ≈3 mm gap / panel width + ≈3 mm gap
- A Panel length = min. 597 / max. 2500 mm *
- B Panel width = min. 247 / max. 700 mm *
- X Mesh thickness

* The dimensions depend on the chosen system and mesh pattern

Typical grid layout

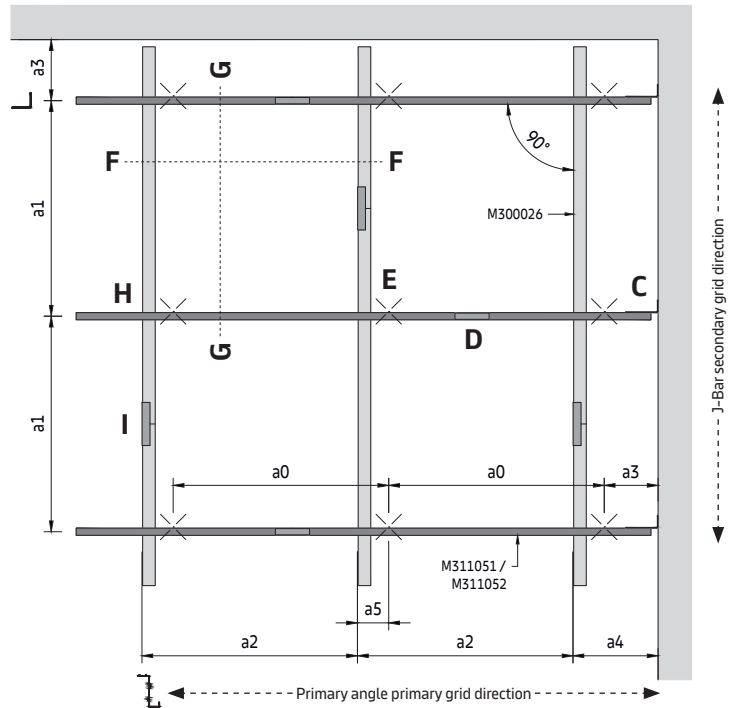

To determine suspension layout

The module length (M) of the requested ceiling is equal to the distance between the J-Bar centres (a2).

On the appropriate spacing table, read down the column headed (a2) to the required module length then read across to determine the suspension point spacing (a0) and primary angle spacing (a1).

The shown values are maximum allowed distances and can be reduced but not exceeded.

MESH R-H 200 / MESH R-H 200 MT
D03.101.1

Detail K

Optional security bracket (screwed version)

The security bracket serves to secure the panels and prevents them from being removed.

Panel installation / locking (example with MESH R-H 200)

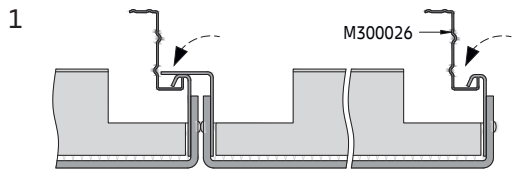

When using the screwed optional security bracket, panel by panel is installed and secured immediately.

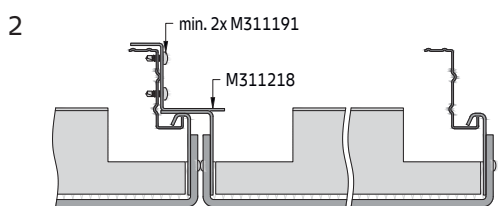

The bracket is placed at the crossing point between the panels. There are two options (A / B) of how the security bracket can be installed. Use at minimum 2 self-drilling screws to fix it. One security bracket per panel is needed.

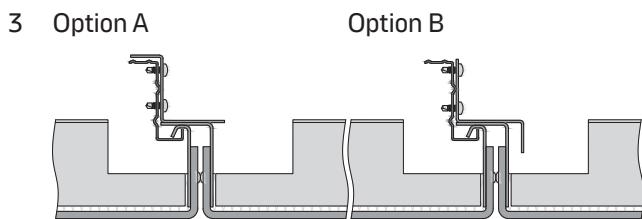

Follow this row by row, until the ceiling is completely installed and locked. The last panel remains unsecured. If panels are to be removed, the ceiling must be opened from the last panel to the desired area.

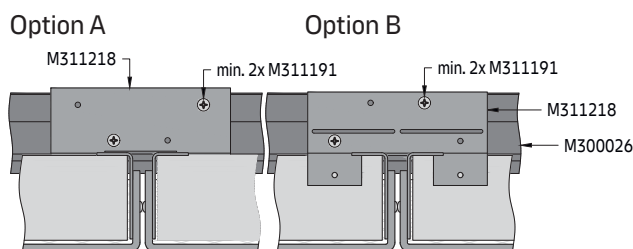

Front side view

Locked position

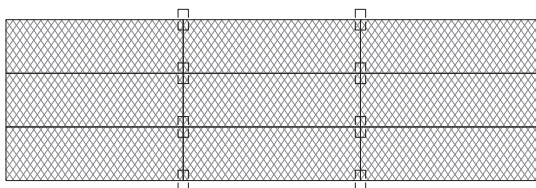

MESH R-H 200 / MESH R-H 200 MT

D03.101.1

Material required per m² (no waste included)

System without additional load [pcs/m²]

Components	a2 [mm]	1200	1600	1800	2000	2200	2500
M300026	J-Bar	0.21	0.16	0.14	0.13	0.12	1.00
M311051	Primary angle 27 x 22 mm	0.28	0.44	0.56	0.33	0.44	0.44
M311053	Splice connector for primary angle *	0.28	0.45	0.56	0.34	0.45	0.45
M300140	Wall anchor	0.09	0.14	0.17	0.11	0.14	0.14
M300343	Splice connector for J-Bar	0.21	0.16	0.14	0.13	0.12	0.11
M311099	Threaded rod M6 x 1000 mm	0.70	0.84	0.93	1.00	1.22	1.07
M311103	Hexagonal nut M6	0.19	0.28	0.33	0.25	0.32	0.30
M311105	Washer	0.10	0.14	0.17	0.13	0.16	0.15
M311303	Hexagonal bolt M6 x 16 mm	0.19	0.28	0.33	0.25	0.32	0.30

*Option with M6 bolt and nut

The shown quantities are theoretical and based on an ideal layout, without considering the actual room layout. The ideal layout is based on a calculation of 10 x 10 m (100 m²). This calculation does not allow any damage, spare nor wastage. The final quantities and type of suspension have to be checked before ordering. Soffit and wall fixings by others.

Not including perimeter trims, optional security brackets and extraction tools.

MESH R-H 200 / MESH R-H 200 MT

Direct suspended J-Bar
Concealed grid solution for indoor applications

General information

- Concealed hook-on grid system for small rooms with low cavity
- For perpendicular or radial installation
- J-Bar made of galvanised steel
- Typical ceiling weight 8.0 - 9.5 kg/m² (indicative value for panels, without additional load)
- Panels are easily installed and fully demountable
- Security option available
- Long side suspension option
- MESH R-H 200 MT Megapanel option (up to 1200 x 1202 mm)

Isometric view

Perimeter solutions on separate datasheet.

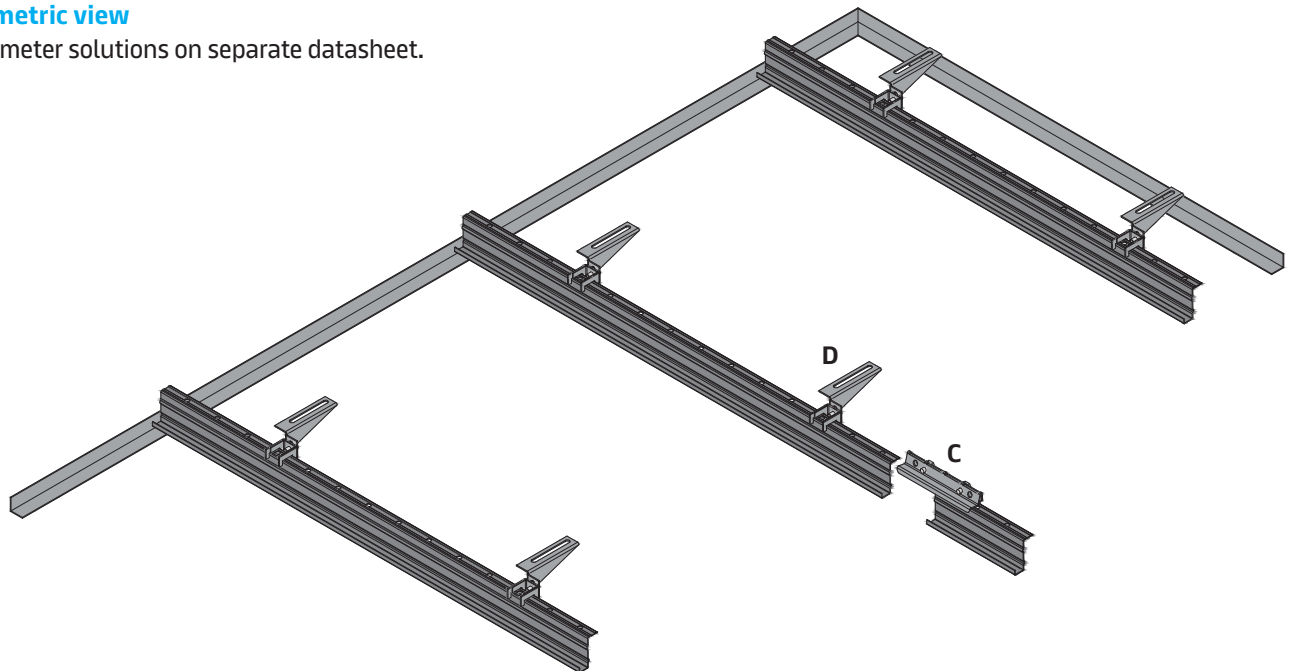

The use of a primary grid system is recommended, as this simplifies levelling and the alignment of the ceiling.

Vario Design & bespoke layout options

Vario Design

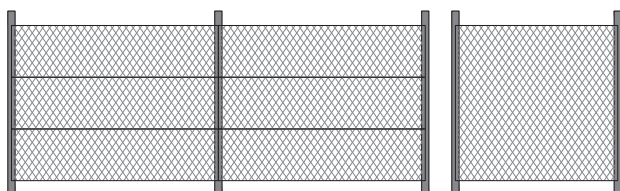

Bespoke (on request)

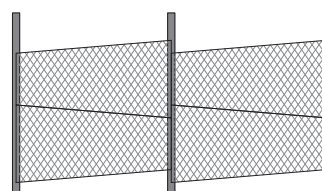

Section A (MESH R-H 200)

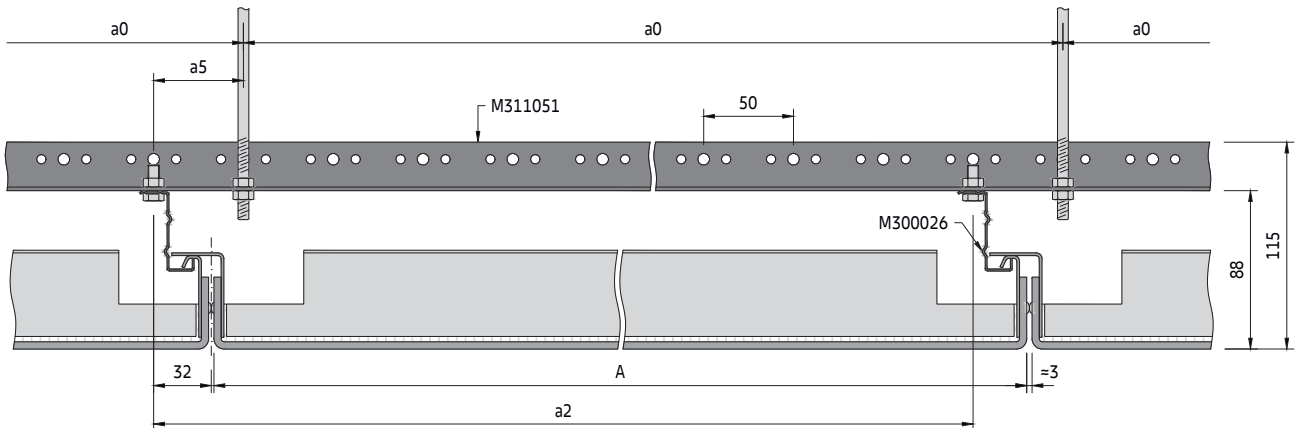

The panels should be installed with a ≈ 3 mm open gap on the short side, which enables installation.

Section A (MESH R-H 200 MT)

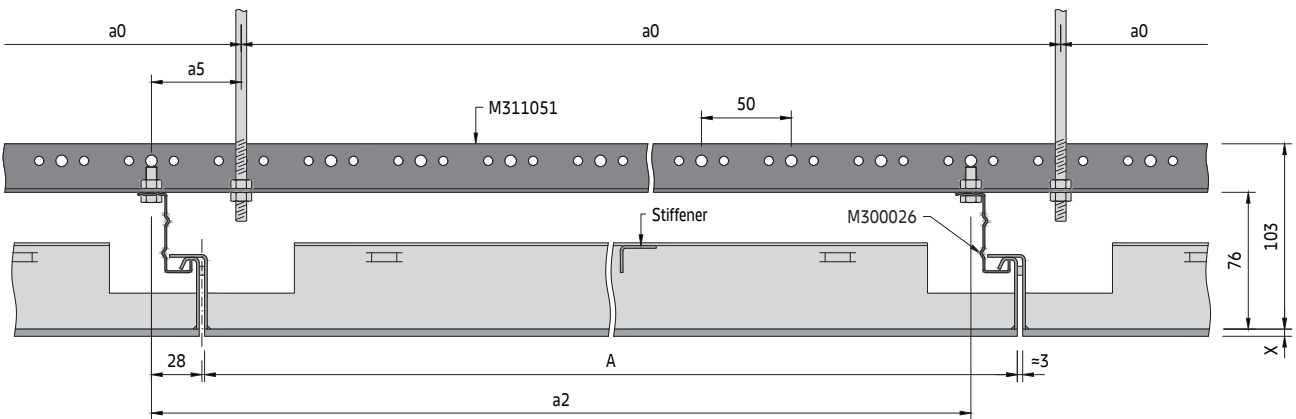

The panels come standard with a ≈ 3 mm spacer on the short side. Panels >2000 mm length with additional welded stiffener.

Secondary grid components

Standard components

- M300026 J-Bar
- M300343 Splice connector for J-Bar
- M300131 Direct hanger for J-Bar

Optional components

- M311218 Security bracket (screwed option)
- M311191 Self-drilling screw 3.5 x 9.5 mm

J-Bar

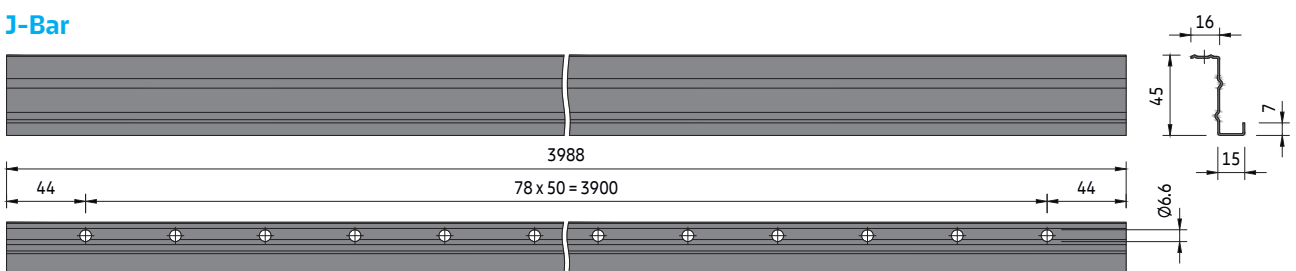

Section B (MESH R-H 200)

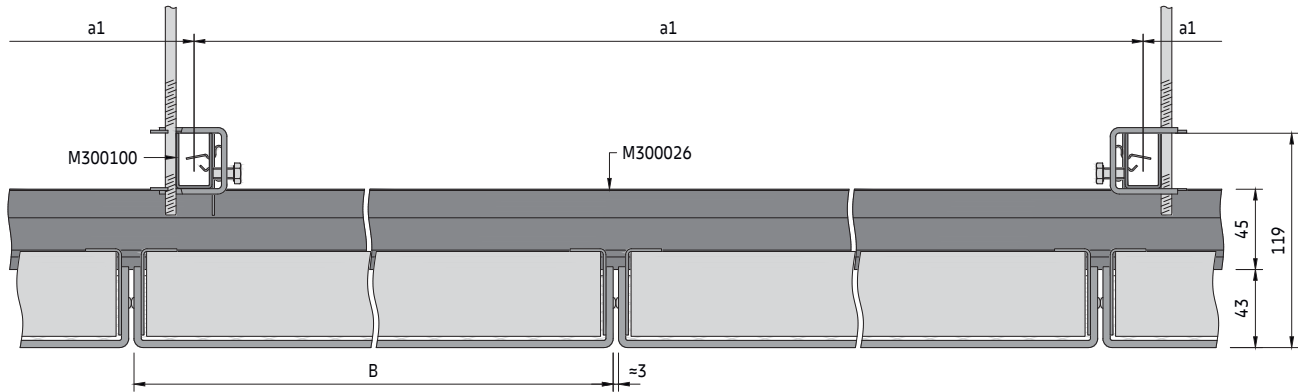

The panels should be installed with a ≈ 3 mm open gap on the long side, which enables installation.

Section B (MESH R-H 200 MT)

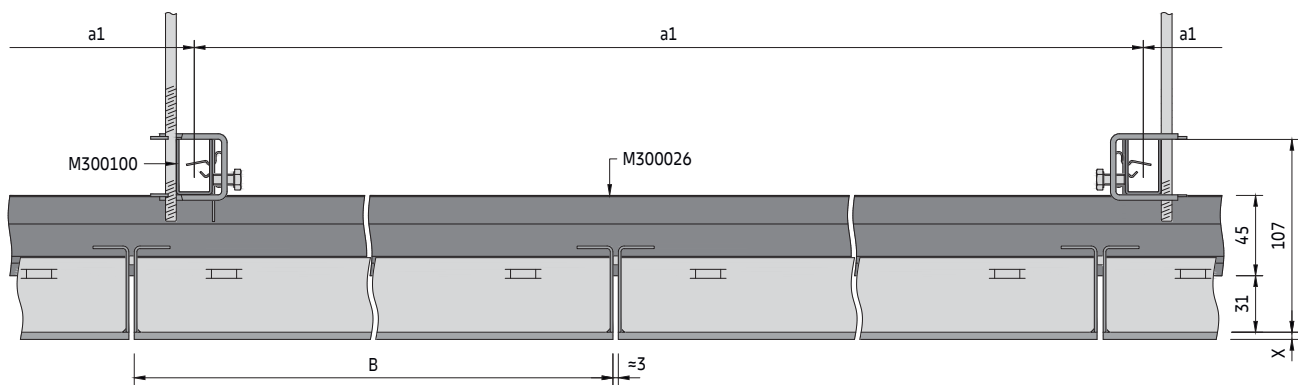

The panels come standard with a ≈ 3 mm spacer on the long side.

MESH R-H 200 / MESH R-H 200 MT
D03.101.2

Spacing

a2 [mm]	System without additional load		System with additional load +4 kg/m²	
	a0 [mm]	a1 [mm]	a0 [mm]	a1 [mm]
600	600	1500	600	1500
650	650	1500	650	1200
700	700	1500	700	1200
750	750	1500	750	1200
800	800	1500	800	1200
850	850	1500	850	1200
900	900	1500	900	1200
950	950	1500	950	1200
1000	1000	1500	1000	1200
1050	1050	1500	1050	1200
1100	1100	1500	1100	1200
1150	1150	1200	1150	1200
1200	1200	1200	1200	1200
1250	1250	1200	1250	1200
1300	1300	1200	1300	1000
1350	1350	1200	1350	1000
1400	1400	1200	1400	1000
1450	1450	1200	1450	1000
1500	1500	1200	1500	1000
1550	1550	1200	1550	1000
1600	1600	1200	1600	800
1650	1650	1000	1650	800
1700	1700	1000	1700	800
1750	1750	1000	1750	600
1800	1800	1000	1800	600
1850	1850	800	1850	600
1900	1900	800	1900	600
1950	1950	800	1950	600
2000	2000	800	2000	600
2050	2050	800	2050	600
2100	2100	800	2100	600
2150	2150	800	2150	600
2200	2200	800	2200	600
2250	2250	800	2250	600
2300	2300	800	2300	600
2350	2350	800	2350	600
2400	2400	800	2400	600
2450	2450	800	2450	600
2500	2500	800	2500	600

Parameters

- a0 Distance between J-Bar suspension points = max. 1900 mm
- a1 Max. distance between direct hangers
- a2 Distance between J-Bars = panel length + ≈3 mm gap
- a3 Distance from wall = max. 200 mm
- a4 Distance from wall = max. panel length
- a5 Distance between panel joint and top fixing = max. 80 mm
- M Module size = panel length + ≈3 mm gap / panel width + ≈3 mm gap
- A Panel length = min. 597 / max. 2500 mm *
- B Panel width = min. 247 / max. 700 mm *
- X Mesh thickness

* The dimensions depend on the chosen system and mesh pattern

Typical grid layout

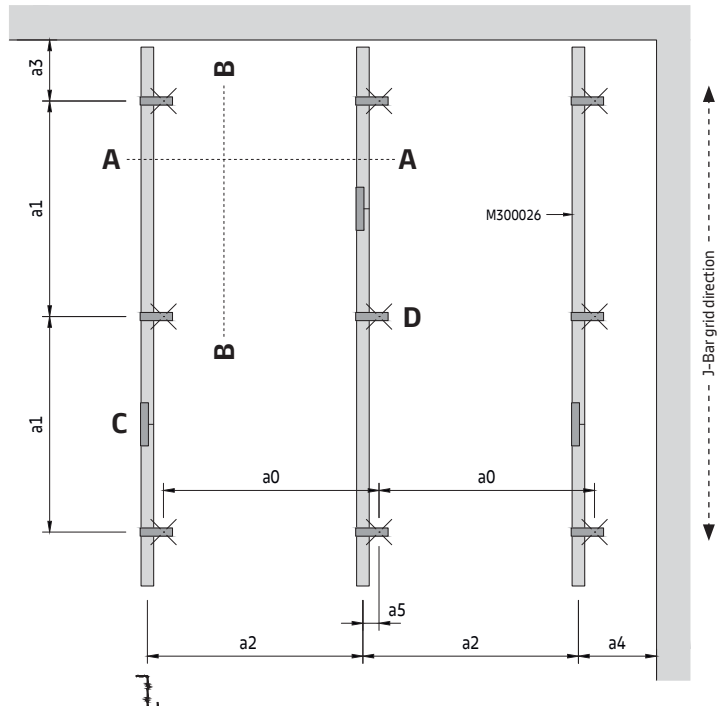

To determine suspension layout

The module length (M) of the requested ceiling is equal to the distance between the J-Bar centres (a2).

On the appropriate spacing table, read down the column headed (a2) to the required module length then read across to determine the suspension point spacing (a0) and direct hanger spacing (a1).

The shown values are maximum allowed distances and can be reduced but not exceeded.

MESH R-H 200 / MESH R-H 200 MT
D03.101.2

Detail C

Splice connection

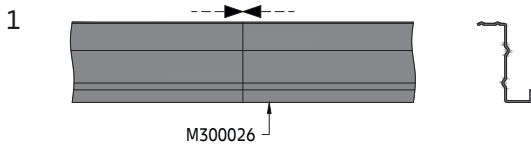

Once the J-Bars are installed, the ends should be brought together without a gap.

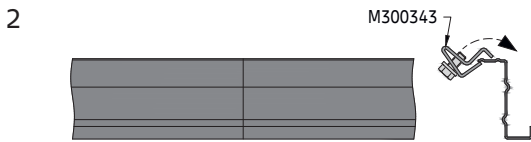

The connectors for the J-Bars must be inserted from above.

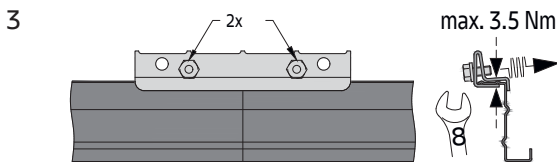

Use the bolts to secure the connector. Stagger the joints.

Detail D

Direct hanger installation

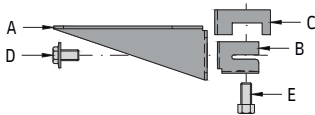

The direct hanger consists of five pre-assembled components (A, B, C, D, E).

MESH R-H 200

MESH R-H 200 MT

Part A is attached to the soffit first. The distance from the J-Bar to the attachment point must not exceed 70 mm.

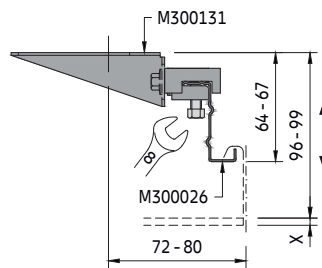
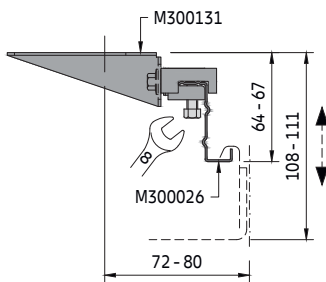

Part B is not tightened, so the J-Bar can be inserted horizontally. Tightening the bolts (part D, E) creates a stable connection. Before that, the height should be set up and part C inserted from above. Part C is positioned between part A and B and prevents the J-Bar from falling out of the hanger.

The distance between the J-Bars should be measured exactly, otherwise the tiles / panels are difficult to install and elements could fall out.

Optional installation

MESH R-H 200

MESH R-H 200 MT

The direct hanger can optionally also be installed vertically. To do this, the components must first be disassembled. The shorter side of part A is then attached to the soffit.

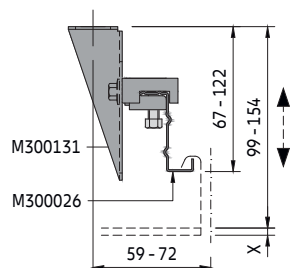
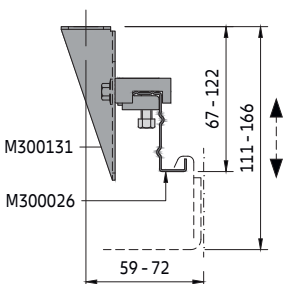

MESH R-H 200 / MESH R-H 200 MT
D03.101.2

Detail E

Panel insertion (example with MESH R-H 200)

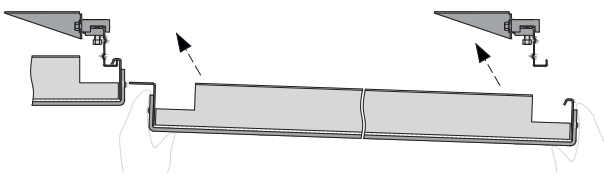
- 1 

First place the panels with the outward bend short side above the neighbour panel to the left.

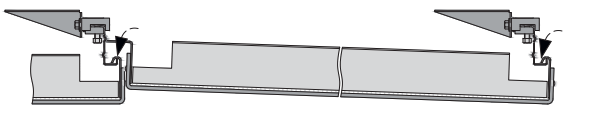
- 2 

Hook-on the opposite side with the hook detail on the J-Bar to the right. The panel will rest now on the neighbour panel to the left and the J-Bar to the right.

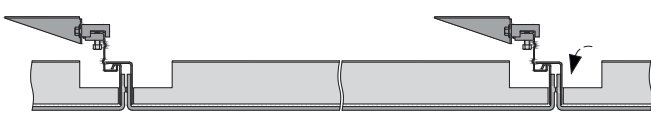
- 3 

Continue with the next panel.

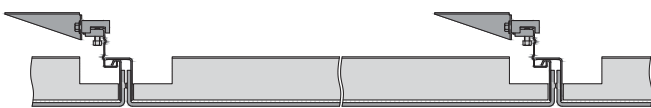
- 4 

Panel extraction (example with MESH R-H 200)

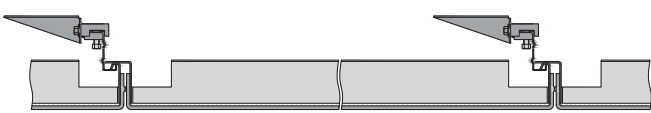
- 1 

With a closed ceiling, any panel can be removed as long as there are no obstacles such as service integrations, etc.

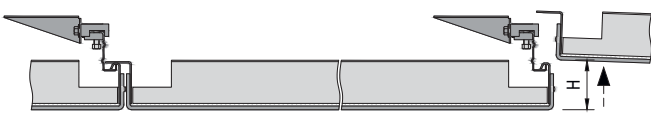
- 2 

Lift the neighbour panel to the right.

MESH R-H 200: (H) = min. 55 mm
MESH R-H 200 MT: (H) = min. 52 mm

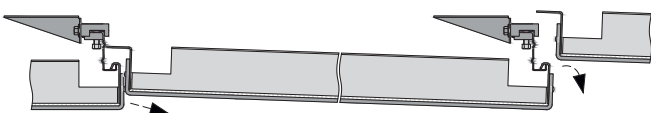
- 3 

Detach the panel that is to be removed from the J-Bar.

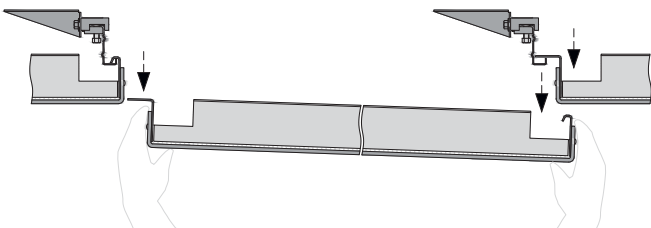
- 4 

Remove it downwards and store the panel in a safe place so that it cannot be damaged. The neighbour panel will rest again on the J-Bar.

MESH R-H 200 / MESH R-H 200 MT
D03.101.2

Detail K

Optional security bracket (screwed version)

The security bracket serves to secure the panels and prevents them from being removed.

Panel installation / locking (example with MESH R-H 200)

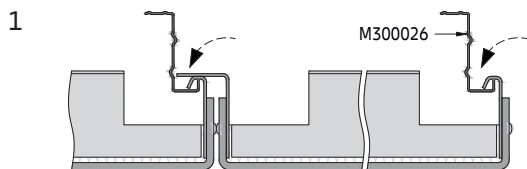

When using the screwed optional security bracket, panel by panel is installed and secured immediately.

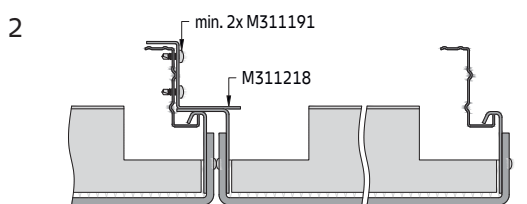

The bracket is placed at the crossing point between the panels. There are two options (A / B) of how the security bracket can be installed. Use at minimum of 2 self-drilling screws to fix it. One security bracket per panel is needed.

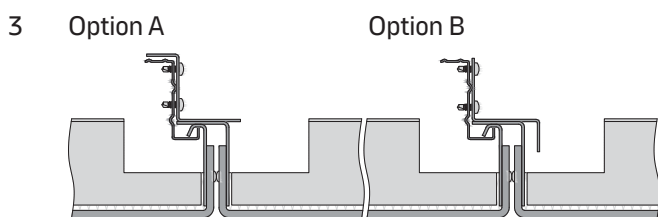

Follow this row by row, until the ceiling is completely installed and locked. The last panel remains unsecured. If panels are to be removed, the ceiling must be opened from the last panel to the desired area.

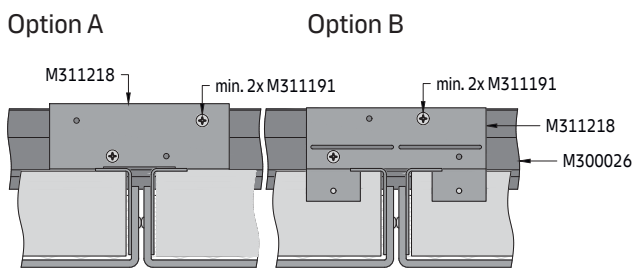

Front side view

Locked position

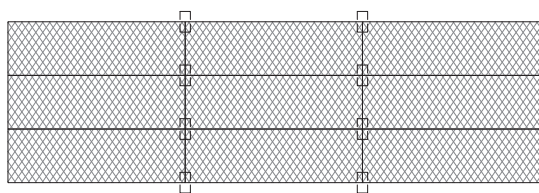

MESH R-H 200 / MESH R-H 200 MT

D03.101.2

Material required per m² (no waste included)System without additional load [pcs/m²]

Components		a2 [mm]	1200	1600	1800	2000	2200	2500
M300026	J-Bar		0.21	0.16	0.14	0.13	0.12	0.10
M300131	Direct hanger for J-Bar		0.69	0.52	0.56	0.63	0.57	0.50
M300343	Splice connector for J-Bar		0.21	0.16	0.14	0.13	0.12	0.11

The shown quantities are theoretical and based on an ideal layout, without considering the actual room layout. The ideal layout is based on a calculation of 10 x 10 m (100 m²). This calculation does not allow any damage, spare nor wastage. The final quantities and type of suspension have to be checked before ordering. Soffit and wall fixings by others. Not including perimeter trims, optional security brackets and extraction tools.

MESH R-H 215 / MESH R-H 215 MT

U-Profile primary grid + H-Profile 35 secondary grid
Concealed grid solution for indoor applications

General information

- Concealed hook-on grid system for medium and large rooms
- For perpendicular installation on U-Profile primary grid
- H-Profile 35 made of aluminium
- Typical ceiling weight 8.0 – 9.5 kg/m² (indicative value for panels, without additional load)
- Panels are easily installed and fully demountable
- MESH R-H 215 MT Megapanel option (up to 1200 x 1202 mm)

Isometric view

Select the suspension option E1 - E4.
Perimeter solutions on separate datasheet.

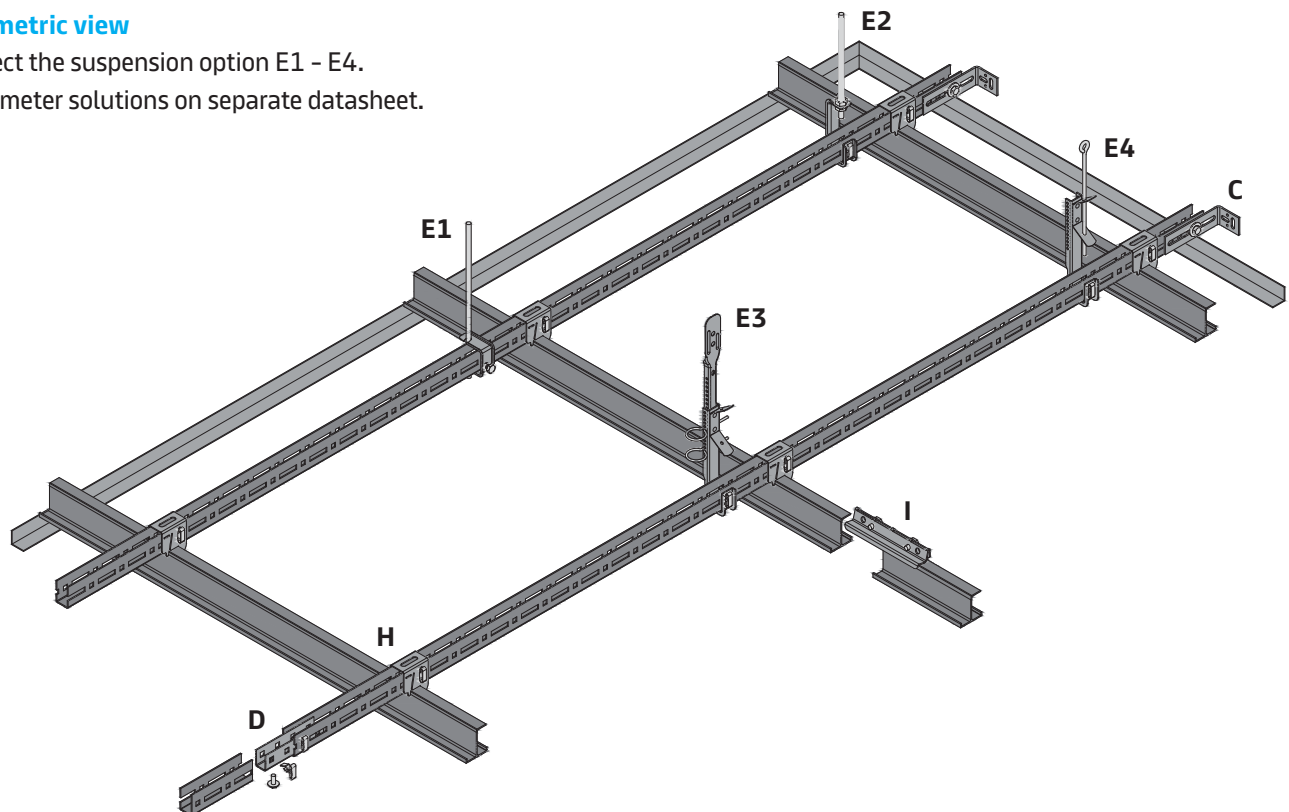

Vario Design layout options

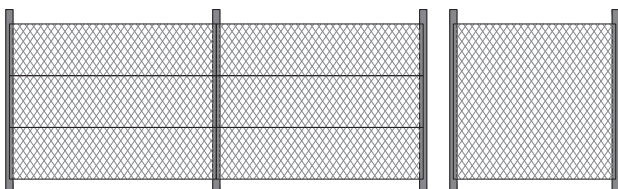

Section F (MESH R-H 215)

Example with suspension option E1

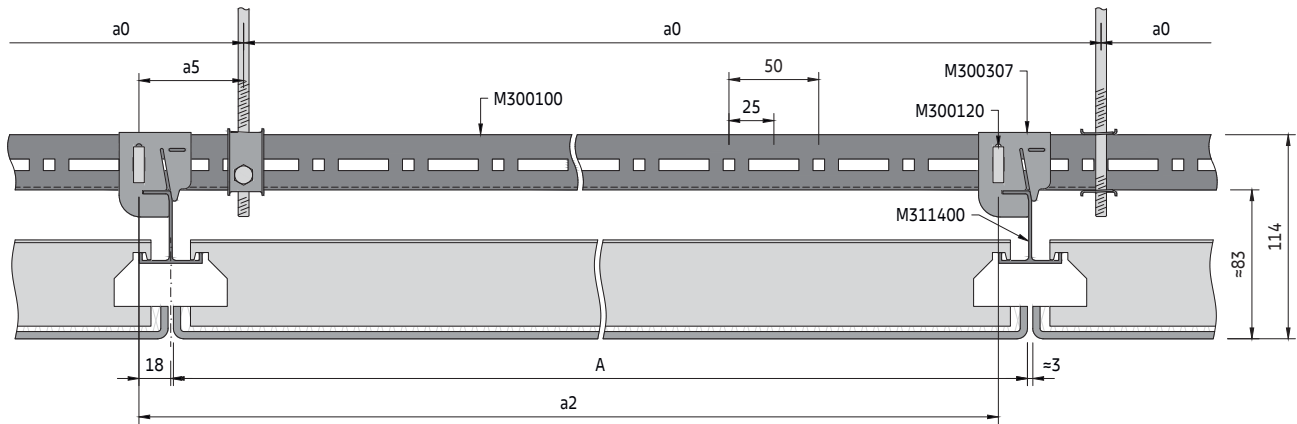

The panels should be installed with a ≈ 3 mm open gap on the short side, which enables installation.

Section F (MESH R-H 215 MT)

Example with suspension option E1

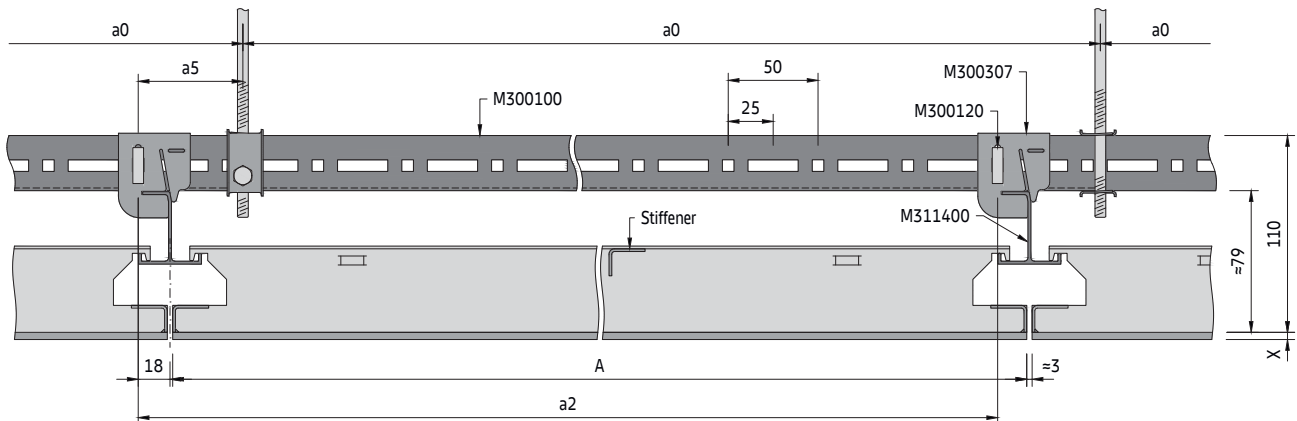

The panels come standard with a ≈ 3 mm spacer on the short sides. Panel >2000 mm length with additional welded stiffener.

Secondary grid components

Standard components:

- M311400 H-Profile 35
- M300343 Splice connector for H-Profile 35
- M300307 Hanger for H-Profile 35
- M300120 Plug-in clip for U-Profile

Optional components

- M311191 Self-drilling screw 3.5 x 9.5 mm

See U-Profile primary grid for primary grid components.

H-Profile 35 secondary grid

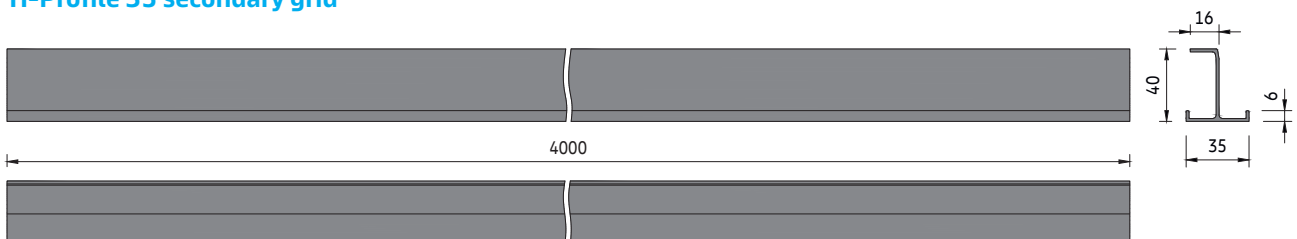

MESH R-H 215 / MESH R-H 215 MT
D03.102

Section G (MESH R-H 215)

Example with suspension option E1

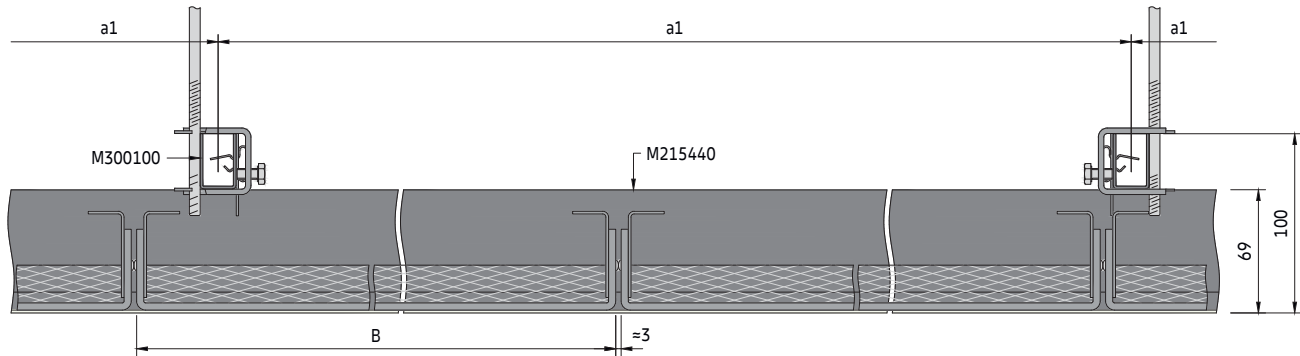

The panels should be installed with a ≈ 3 mm open gap on the long side, which enables installation.

Section G (MESH R-H 215 MT)

Example with suspension option E1

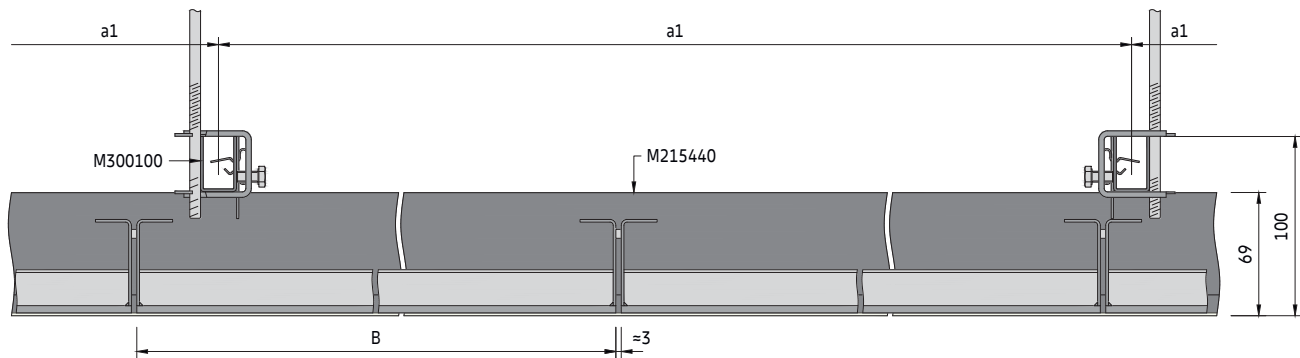

The panels come standard with a ≈ 3 mm spacer on the long side.

Material required per m² (no waste included)

System without additional load [pcs/m²]

Components		a2 [mm]	1200	1600	1800	2000	2200	2500
M300100	U-Profile		0.21	0.24	0.33	0.27	0.28	0.30
M300119	Splice connector for U-Profile		0.21	0.25	0.34	0.27	0.29	0.30
M300120	Plug-in clip for U-Profile		1.07	1.07	1.38	1.04	1.06	1.05
M300140	Wall anchor		0.08	0.10	0.13	0.11	0.11	0.12
M300307	Hanger for H-Profile 35		0.65	0.57	0.70	0.50	0.48	0.45
M300343	Splice connector for H-Profile 35		0.21	0.18	0.14	0.13	0.12	0.10
M311103	Hexagonal nut M6		0.10	0.10	0.10	0.10	0.12	0.12
M311105	Washer		0.10	0.10	0.10	0.10	0.12	0.12
M311303	Hexagonal bolt M6 x 16 mm		0.10	0.10	0.10	0.10	0.12	0.12
M311400	H-Profile 35		0.21	0.18	0.14	0.13	0.12	0.10
Various	Suspension points (E1 - E4)		0.65	0.57	0.70	1.00	0.96	0.89

The shown quantities are theoretical and based on an ideal layout, without considering the actual room layout. The ideal layout is based on a calculation of 10 x 10 m (100 m²). This calculation does not allow any damage, spare nor wastage. The final quantities and type of suspension have to be checked before ordering. Soffit and wall fixings by others. Not including perimeter trims, optional security clips and extraction tools.

MESH R-H 215 / MESH R-H 215 MT
D03.102

Spacing

a2 [mm]	System without additional load		System with additional load +4 kg/m²	
	a0 [mm]	a1 [mm]	a0 [mm]	a1 [mm]
600	1200	1800	1200	1450
650	1300	1700	1300	1200
700	1400	1450	1400	1050
750	1500	1250	750	1500
800	1600	1100	800	1450
850	850	1550	850	1400
900	900	1500	900	1400
950	950	1450	950	1350
1000	1000	1400	1000	1300
1050	1050	1400	1050	1300
1100	1100	1350	1100	1250
1150	1150	1350	1150	1200
1200	1200	1300	1200	1200
1250	1250	1250	1250	1150
1300	1300	1250	1300	1150
1350	1350	1250	1350	1150
1400	1400	1200	1400	1050
1450	1450	1200	1450	1000
1500	1500	1150	1500	900
1550	1550	1150	1550	850
1600	1600	1100	1600	800
1650	1650	1050	1650	750
1700	1700	1000	1700	700
1750	1750	900	1750	650
1800	1800	800	1800	600
1850	1850	750	1850	550
1900	1900	700	1900	500
1950	975	1000	975	950
2000	1000	1000	1000	900
2050	1025	1000	1025	900
2100	1050	1000	1050	900
2150	1075	950	1075	900
2200	1100	950	1100	900
2250	1125	950	1125	850
2300	1150	950	1150	850
2350	1175	950	1175	850
2400	1200	900	1200	850
2450	1225	900	1225	850
2500	1250	900	1250	800

Parameters

- a0 Distance between U-Profile suspension points = max. 1900 mm
- a1 Max. distance between U-Profiles
- a2 Distance between H-Profiles 35 = panel length + ≈3 mm gap
- a3 Distance from wall = max. 200 mm
- a4 Distance from wall = max. panel length
- a5 Distance from U-Profile suspension point to hanger = max. 100 mm
- M Module size = panel length + ≈3 mm gap / panel width + ≈3 mm gap
- A Panel length = min. 597 / max. 2500 mm *
- B Panel width = min. 247 / max. 1350 mm *

* The dimensions depend on the chosen system and mesh pattern

Typical grid layout

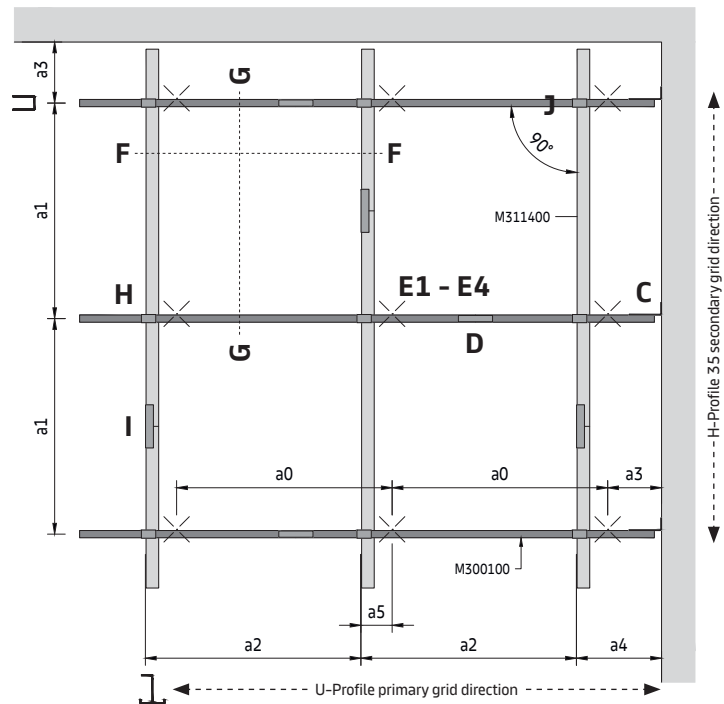

To determine suspension layout

The module length (M) of the requested ceiling is equal to the distance between the H-Profile 35 centres (a2).

On the appropriate spacing table, read down the column headed (a2) to the required module length then read across to determine the suspension point spacing (a0) and U-Profile spacing (a1).

The shown values are maximum allowed distances and can be reduced but not exceeded.

MESH R-H 215 / MESH R-H 215 MT
D03.102

Detail H

Hanger installation

- 1 Place the hanger on the U-profile.

- 2 Fix hanger with plug-in clips at the specified module spacing (inserted vertically or horizontally). If the panel size does not fit with the modulation of the U-Profile (25 mm increments), the plug-in clip needs to be inserted into a long hole. The hanger position can alternatively be fixed by using a pop-rivet or self-drilling screw.

- 3 Insert the H-profile 35 into the hanger, press down the two hanger wings to lock the position of the H-profile 35.

- 4 The H-profile 35 is now locked in position.

Detail I

Splice connection

- 1 Once the H-profiles 35 are installed under the U-Profiles, the ends should be brought together without a gap.

- 2 The connectors for the H-profile 35 must be inserted from above.

- 3 Use the bolts to secure the connector. Stagger the joints.

MESH R-H 215 / MESH R-H 215 MT

D03.102

Detail J

Panel insertion (example with MESH R-H 215)

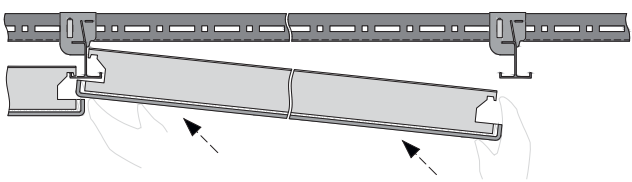
- 1  First hang the panels with the two hooks at one end.

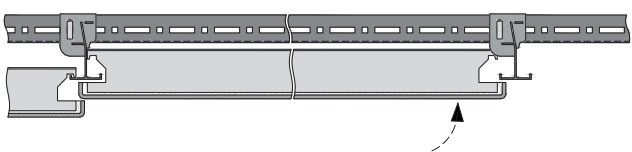
- 2  Lift the opposite end of the panel to a horizontal position.

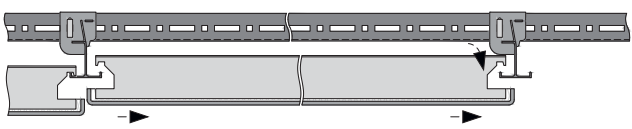
- 3  Now hang the opposite end of the panel with the hooks.

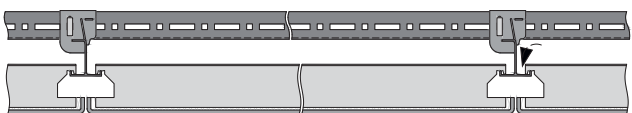
- 4  Make sure that all four hooks on the panel are hooked onto the H-Profiles 35.

Panel extraction (example with MESH R-H 215)

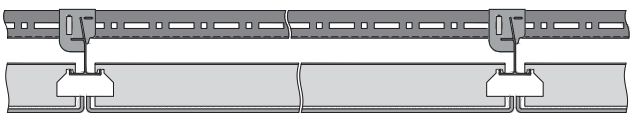
- 1  With a closed ceiling, any panel can be removed as long as there are no obstacles such as service integrations, etc.

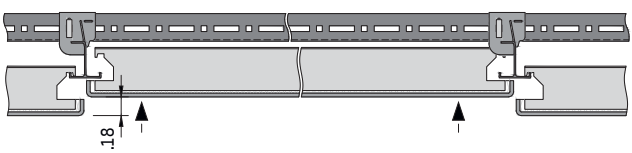
- 2  Lift the panel min. 18 mm.

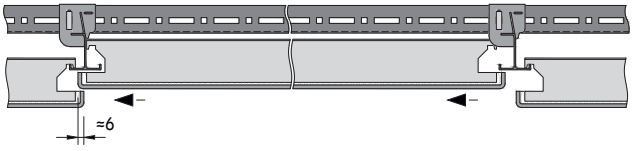
- 3  Slide it horizontally lengthwise (to the left or right) so that the end fits between the next panel and the H-Profile 35.

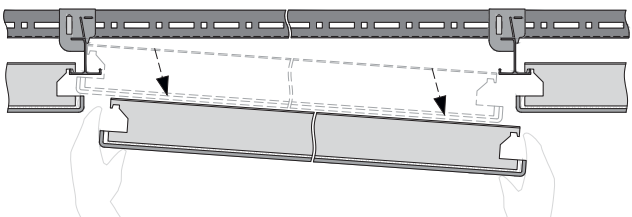
- 4  Remove it downwards and store the panel in a safe place so that it cannot be damaged.

MESH R-H 215 / MESH R-H 215 MT

Direct suspended H-Profile 35
Concealed grid solution for indoor applications

General information

- Concealed hook-on grid system for small rooms with low cavity
- H-Profile 35 made of aluminium
- Typical ceiling weight 7.5 - 9.0 kg/m² (indicative value for panels, without additional load)
- Panels are easily installed and fully demountable
- MESH R-H 215 MT Megapanel option (up to 1200 x 1202 mm)

Isometric view

Perimeter solutions on separate datasheet.

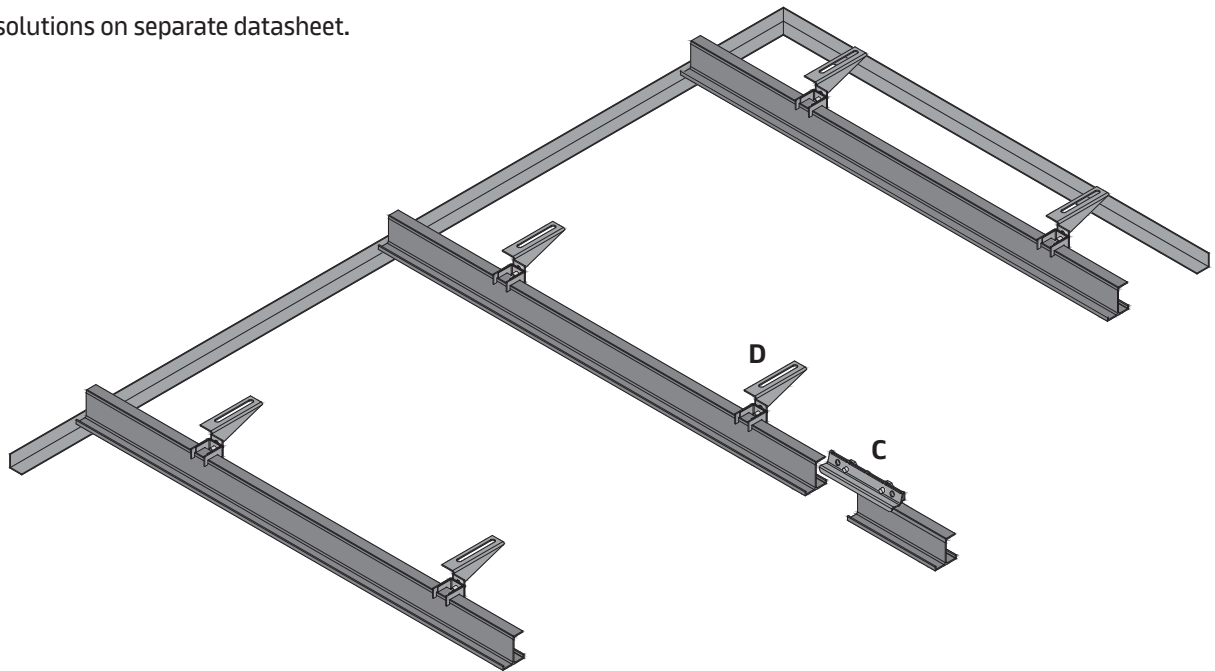

The use of a primary grid system is recommended, as this simplifies levelling and the alignment of the ceiling.

Vario Design layout options

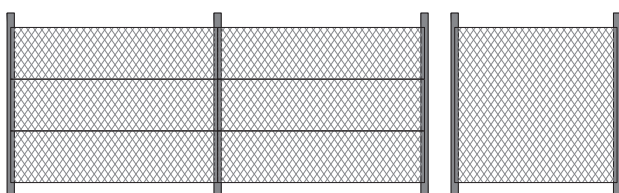

MESH R-H 215 / MESH R-H 215 MT
D03.102.1

Section A (MESH R-H 215)

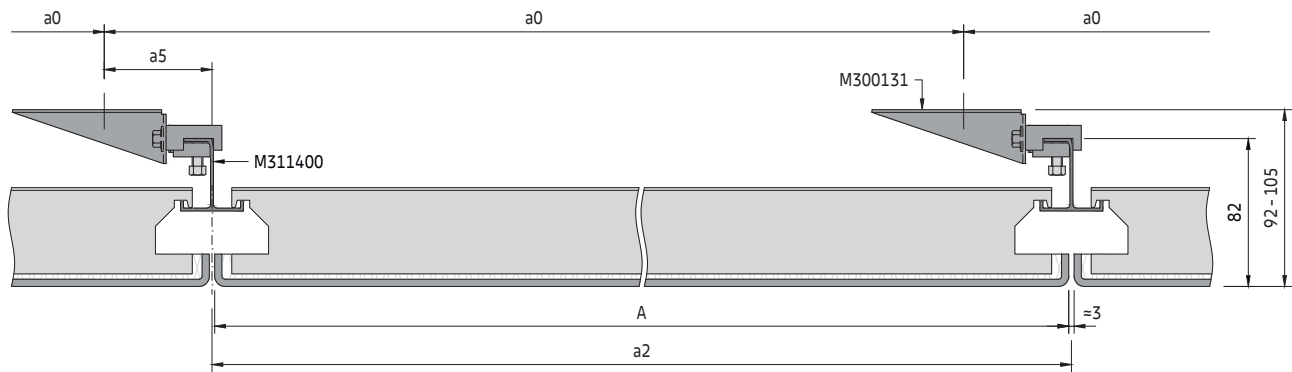

The panels should be installed with a ≈ 3 mm open gap on the short side, which enables installation.

Section A (MESH R-H 215 MT)

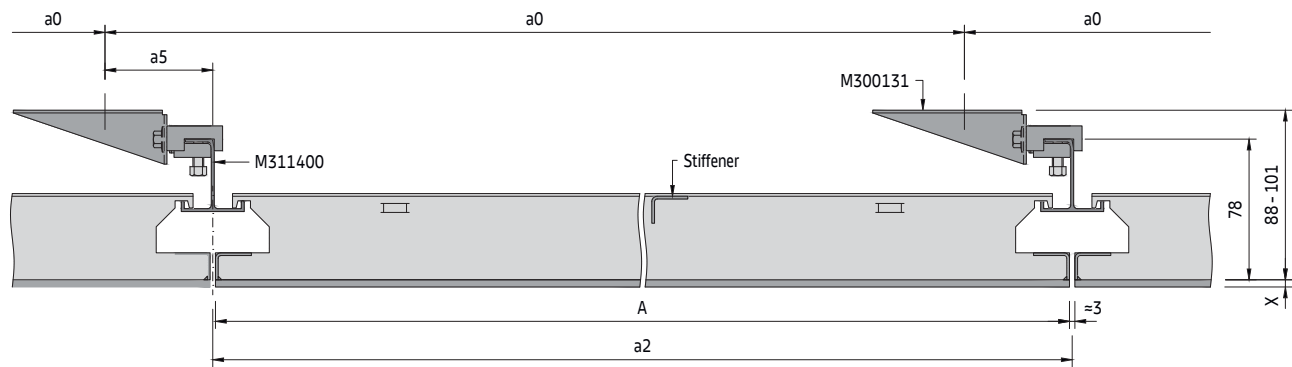

The panels come standard with a ≈ 3 mm spacer on the short side. Panels >2000 mm length with additional welded stiffener.

Secondary grid components

Standard components:

- M311400 H-Profile 35
- M300343 Splice connector for H-Profile 35
- M300131 Direct hanger for H-Profile 35

H-Profile 35

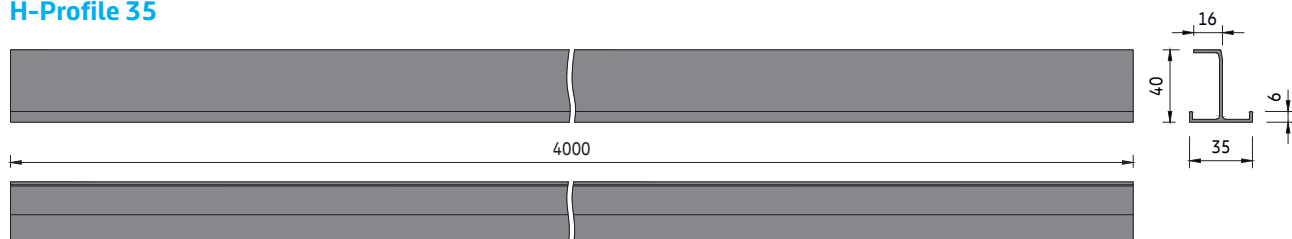

Section B (MESH R-H 215)

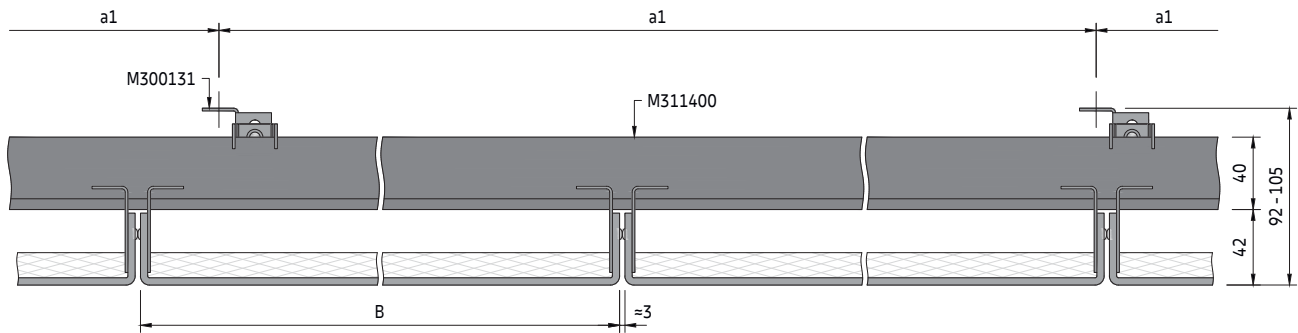

The panels should be installed with a ≈ 3 mm open gap on the long side, which enables installation.

Section B (MESH R-H 215 MT)

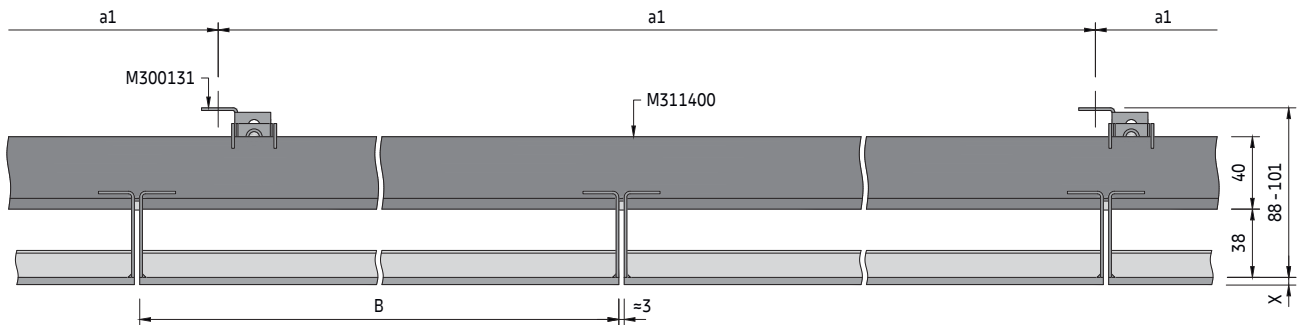

The panels come standard with a ≈ 3 mm spacer on the long side.

Material required per m² (no waste included)

System without additional load [pcs/m²]

Components		a2 [mm]	1200	1600	1800	2000	2200	2500
M300131	Direct hanger for H-Profile 35		0.56	0.52	0.56	0.63	0.57	0.67
M300343	Splice connector for H-Profile 35		0.21	0.18	0.14	0.13	0.11	0.09
M311400	H-Profile 35		0.21	0.18	0.14	0.13	0.11	0.09

The shown quantities are theoretical and based on an ideal layout, without considering the actual room layout. The ideal layout is based on a calculation of 10 x 10 m (100 m²). This calculation does not allow any damage, spare nor wastage. The final quantities and type of suspension have to be checked before ordering. Soffit and wall fixings by others. Not including perimeter trims, optional security clips and extraction tools.

MESH R-H 215 / MESH R-H 215 MT
D03.102.1

Spacing

a2 [mm]	System without additional load		System with additional load +4 kg/m²	
	a0 [mm]	a1 [mm]	a0 [mm]	a1 [mm]
600	600	1500	600	1500
650	650	1500	650	1500
700	700	1500	700	1500
750	750	1500	750	1500
800	800	1500	800	1500
850	850	1500	850	1500
900	900	1500	900	1500
950	950	1500	950	1500
1000	1000	1500	1000	1500
1050	1050	1500	1050	1200
1100	1100	1500	1100	1200
1150	1150	1500	1150	1200
1200	1200	1500	1200	1200
1250	1250	1500	1250	1200
1300	1300	1200	1300	1200
1350	1350	1200	1350	1200
1400	1400	1200	1400	1000
1450	1450	1200	1450	1000
1500	1500	1200	1500	1000
1550	1550	1200	1550	800
1600	1600	1200	1600	800
1650	1650	1200	1650	800
1700	1700	1000	1700	600
1750	1750	1000	1750	600
1800	1800	1000	1800	600
1850	1850	800	1850	600
1900	1900	800	1900	600
1950	1950	800	1950	600
2000	2000	800	2000	600
2050	2050	800	2050	600
2100	2100	800	2100	600
2150	2150	800	2150	600
2200	2200	800	2200	400
2250	2250	600	2250	400
2300	2300	600	2300	400
2350	2350	600	2350	400
2400	2400	600	2400	400
2450	2450	600	2450	400
2500	2500	600	2500	400

Parameters

- a0 Distance between H-Profile 35 suspension points = max. 1900 mm
- a1 Max. distance between direct hangers
- a2 Distance between H-Profiles 35 = panel length + ≈3 mm gap
- a3 Distance from wall = max. 200 mm
- a4 Distance from wall = max. panel length
- a5 Distance panel joint and top fixing = max. 70 mm
- M Module size = panel length + ≈3 mm gap / panel width + ≈3 mm gap
- A Panel length = min. 597 / max. 2500 mm *
- B Panel width = min. 247 / max. 700 mm *

* The dimensions depend on the chosen system and mesh pattern

Typical grid layout

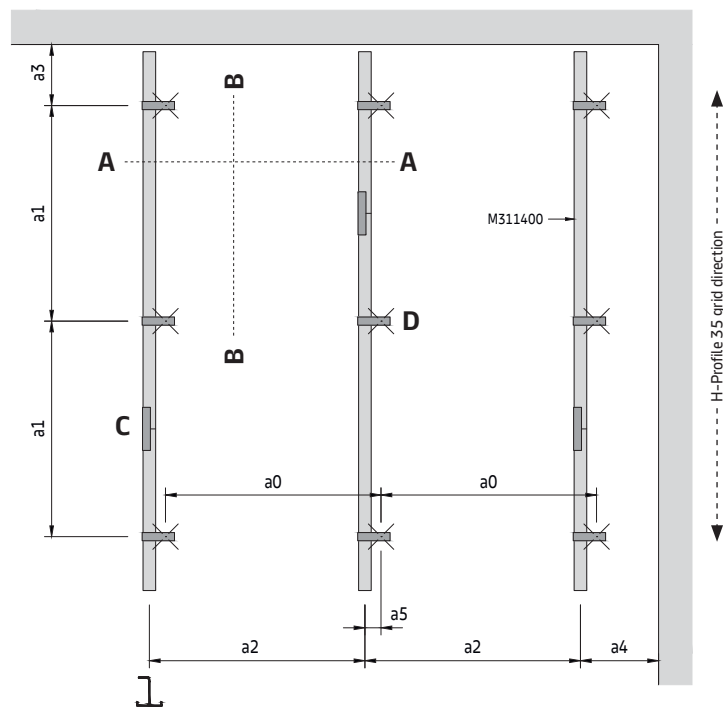

To determine suspension layout

The module length (M) of the requested ceiling is equal to the distance between the H-Profile 35 centres (a2).

On the appropriate spacing table, read down the column headed (a2) to the required module length then read across to determine the suspension point spacing (a0) and direct hanger spacing (a1).

The shown values are maximum allowed distances and can be reduced but not exceeded.

MESH R-H 215 / MESH R-H 215 MT
D03.102.1

Detail C

Splice connection

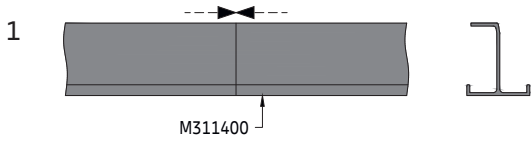

Once the H-Profiles 35 are installed, the ends should be brought together without a gap.



The connectors for the H-Profile 35 must be inserted from above.

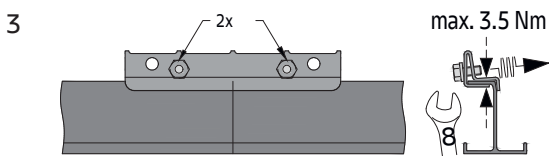

Use the bolts to secure the connector. Stagger the joints.

Detail D

Direct hanger installation

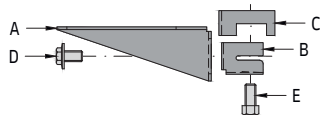

The direct hanger consists of five pre-assembled components (A, B, C, D, E).

MESH R-H 215

MESH R-H 215 MT

Part A is attached to the soffit first. The distance from the H-Profile 35 to the attachment point must not exceed 70 mm.

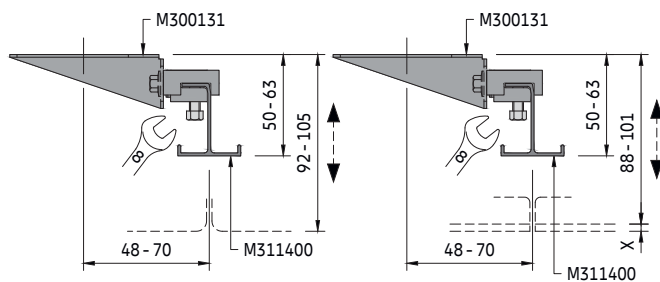

Part B is not tightened, so the H-Profile 35 can be inserted horizontally. Tightening the bolts (part D, E) creates a stable connection. Before that, the height should be set up and part C inserted from above. Part C is positioned between part A and B and prevents the H-Profile 35 from falling out of the hanger.

Optional installation

MESH R-H 215

MESH R-H 215 MT

The distance between the H-Profile 35 should be measured exactly, otherwise the tiles / panels are difficult to install and elements could fall out.

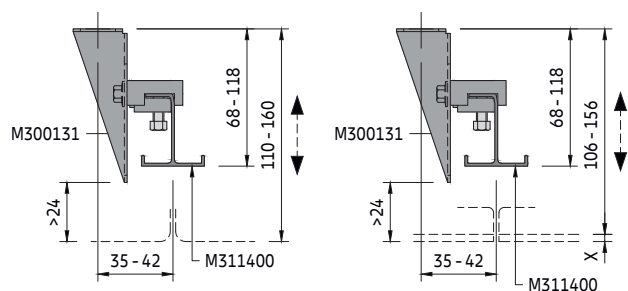

The direct hanger can optionally also be installed vertically. To do this, the components must first be disassembled. The shorter side of part A is then attached to the soffit.

MESH R-H 215 / MESH R-H 215 MT
D03.102.1

Detail E

Panel insertion (example with MESH R-H 215)

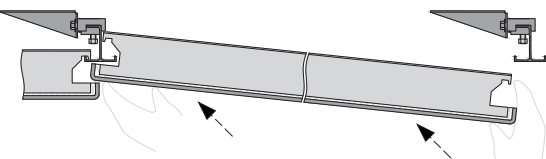
- 1  First hang the panels with the two hooks at one end.

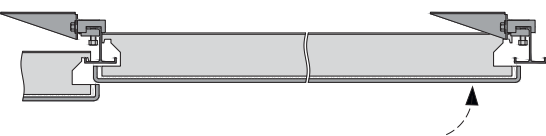
- 2  Lift the opposite end of the panel to a horizontal position.

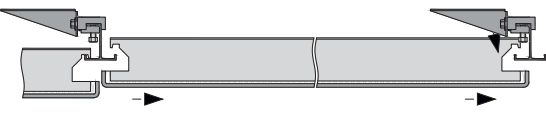
- 3  Now hang the opposite end of the panel with the hooks.

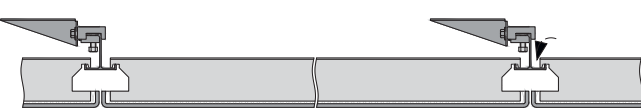
- 4  Make sure that all four hooks on the panel are hooked onto the H-Profiles 35.

Panel extraction (example with MESH R-H 215)

- 1  With a closed ceiling, any panel can be removed as long as there are no obstacles such as service integrations, etc.

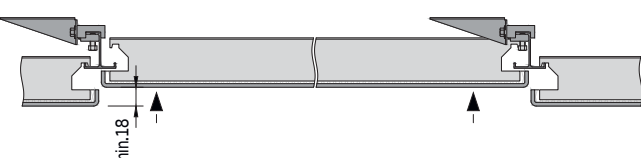
- 2  Lift the panel min. 18 mm.

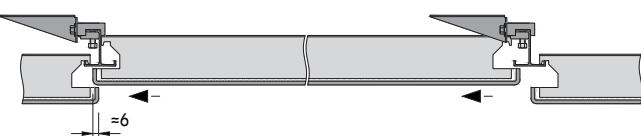
- 3  Slide it horizontally lengthwise (to the left or right) so that the end fits between the next panel and the H-Profile 35.

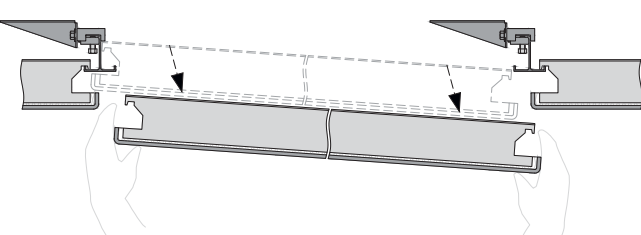
- 4  Remove it downwards and store the panel in a safe place so that it cannot be damaged.



MESH F-H 600

Ivanja Reka Primary School, Zagreb, Croatia © Miljenko Hegedić.



***Free Span
Corridor Ceilings***

MESH F-L 601 / MESH F-L 601 MT

Perimeter trim range
Corridor solution for indoor applications

General information

- Lay-in system for corridors
- Range of perimeter trims in RAL 9010 (further colour options on request)
- Typical ceiling weight 10.0 – 25.5 kg/m² (indicative value for panels, without additional load)
- Panels are easily installed and fully demountable

Isometric view

Example with RA 1 perimeter trim

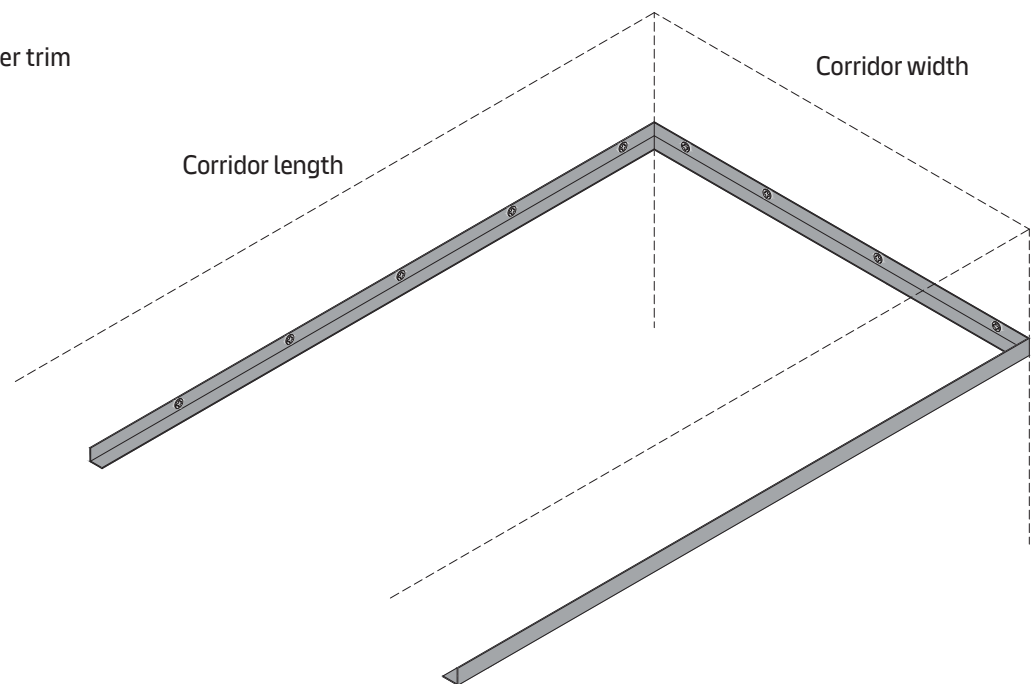

Vario Design layout options

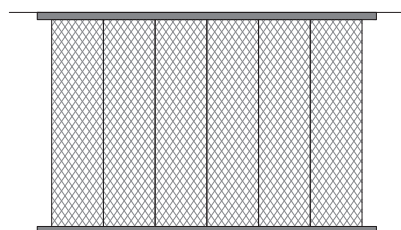

Installation height (H)

Perimeter trim	Panel length (A) [mm]			
	1000	1500	2000	2500
RA 1, RA 1 S, RA 2	225	250	280	310
RA 3, RA 3 S	75	75	75	75

The shown values are min. needed heights.

MESH F-L 601 / MESH F-L 601 MT
D03.400

Section A (MESH F-L 601)

Example with RA 1 perimeter trim

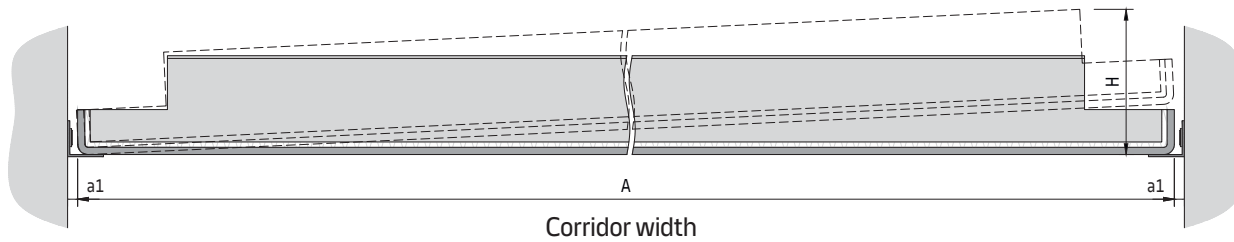

Section A (MESH F-L 601)

Example with RA 5 shadowline perimeter trim

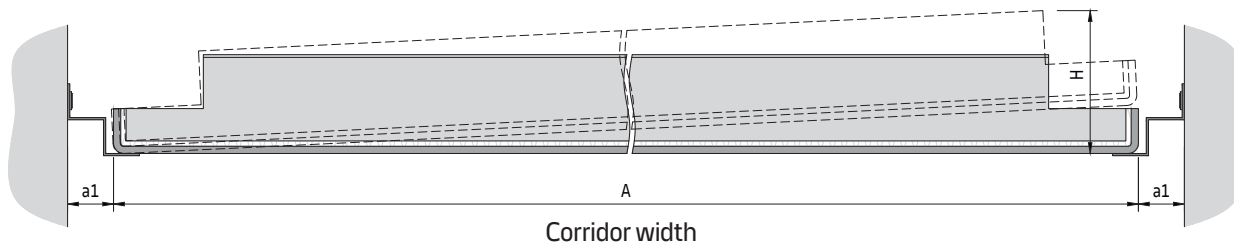

Section B (MESH F-L 601)

Example with RA 1 perimeter trim

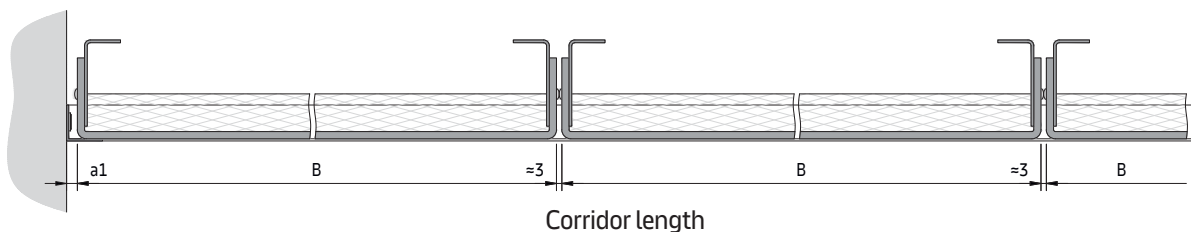

The panels should be installed with a ≈ 3 mm open gap on the long side, which enables installation.

How to define the panel length (A)

Measure the corridor width. The distance measured at the widest point is used to define the panel length.

Panel length (A) = corridor width - 2x a1

In the narrower corridor areas, the panels may have to be cut to size.

See perimeter trim range for (a1) distances, perimeter trim options and detailed information.

Parameters

- a1 Distance from wall to panel (depending on the selected perimeter trim) Distance between perimeter trim fixing points to wall (depending on selected perimeter trim)
- A Panel length = min. 597 / max. 2500 mm *
- B Panel width = min. 247 / max. 700 mm *
- X Mesh thickness

* The dimensions depend on the chosen system and mesh pattern

MESH F-L 601 / MESH F-L 601 MT
D03.400

Section A (MESH F-L 601 MT)

Example with RA 1 perimeter trim

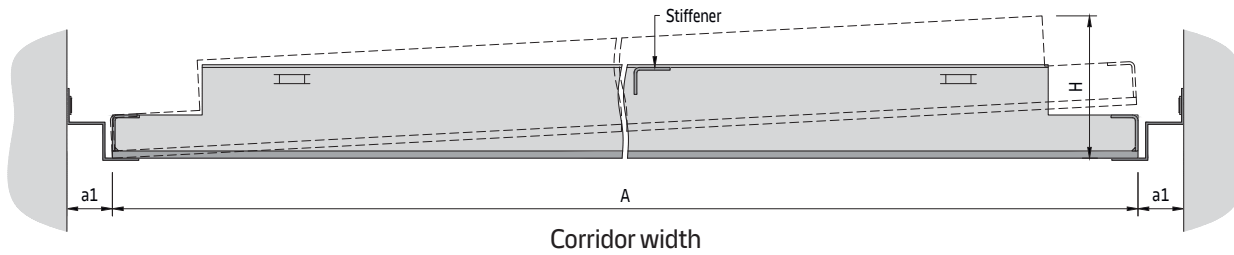

Section A (MESH F-L 601 MT)

Example with RA 5 shadowline perimeter trim

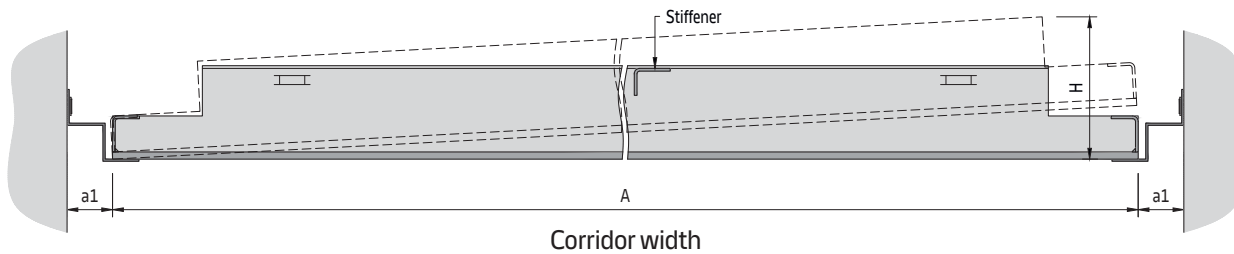

Section B (MESH F-L 601 MT)

Example with RA 1 perimeter trim

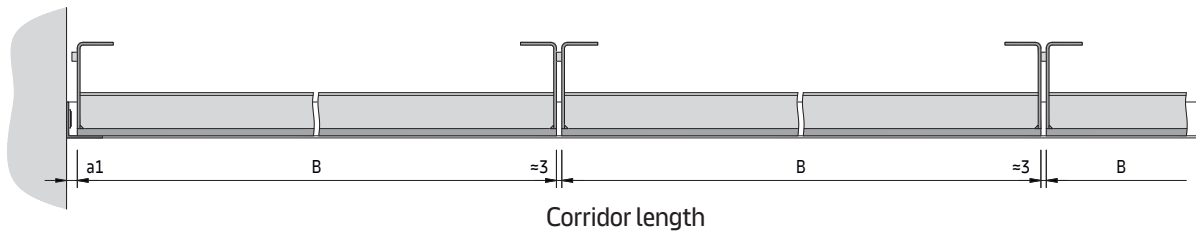

The panels come standard with a ≈ 3 mm spacer on the long side.

Secondary grid components

Optional components:

- | | | | |
|-----------|---------------------------------|-----------|----------------------------------|
| ▪ M215440 | L-Profile RAL 9010 | ▪ M311191 | Self-drilling screw 9.5 x 3.5 mm |
| ▪ M311051 | Primary angle 3000 x 27 x 22 mm | ▪ M311303 | Hexagonal bolt M6 x 16 mm |
| ▪ M311099 | Threaded rod M6 x 1000 mm | ▪ M311305 | Washer |
| ▪ M311103 | Hexagonal nut M6 | ▪ M311330 | Attachment bracket |

MESH F-L 601 / MESH F-L 601 MT
D03.400

Detail C

C1 - Transition with L-Profile
(example with MESH F-L 601)

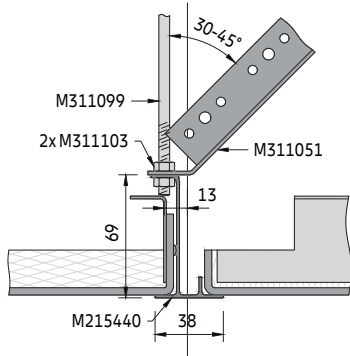

With T-junctions and corners you can use L-Profiles for the transition. The L-Profiles are suspended from the plenum with threaded rods at a distance of max. 1200 mm. The distance from the corner to the first suspension point should be max. 200 mm. The L-Profile is aligned so that it is flush with one of the perimeter trims in the corner.

In order to keep the L-Profile in position, an angle bracing is attached using a primary angle at an angle of 30 to 45°. This is attached to the plenum at the top with an attachment bracket, using a M6 bolt. The end is cut at the bottom and bent to the required angle and attached to the L-profile with an M6 bolt.

C2 - Transition with L-Profile, example with RA 1

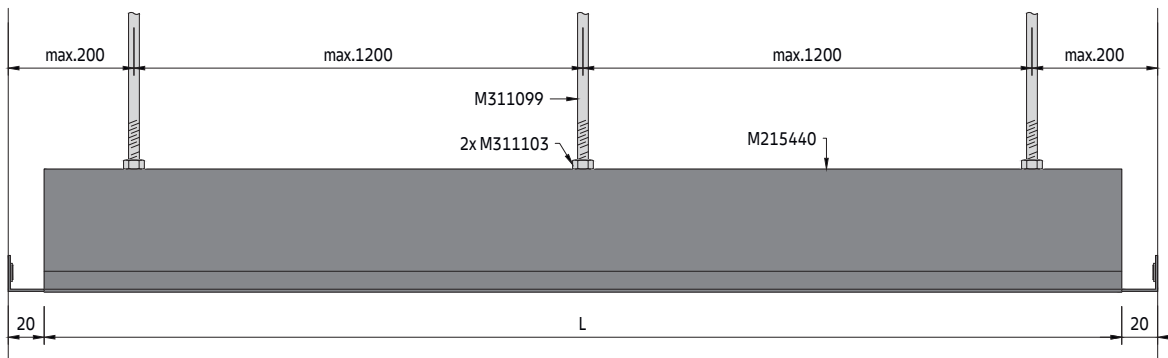

C3 - Transition example with RA 1

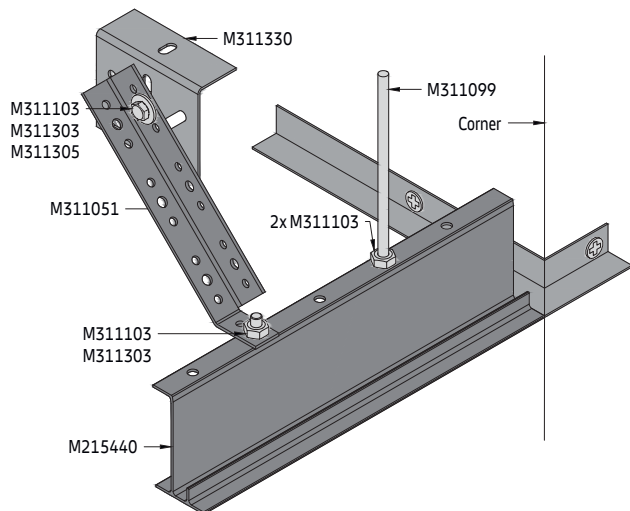

C4 - Transition example with RA 3

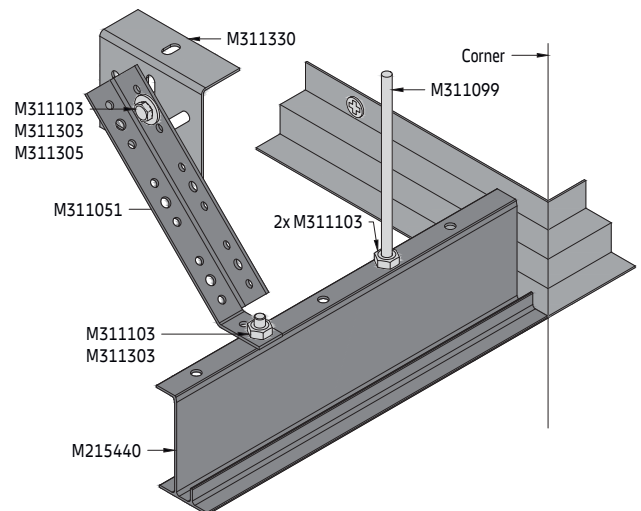

MESH F-L 601 / MESH F-L 601 MT
D03.400

T-junction

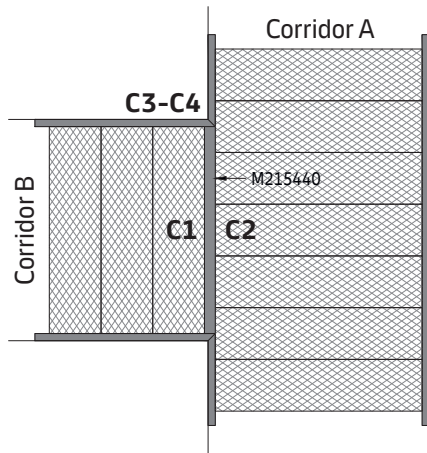

Corridor A runs through, corridor B connects to it and forms a T-junction.

Corner 1

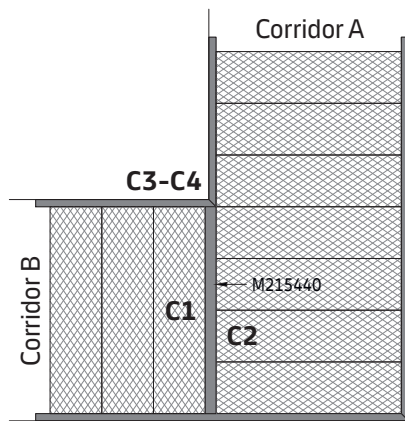

Corridor A runs to the end, corridor B connects to it and forms a transition.

Corner 2

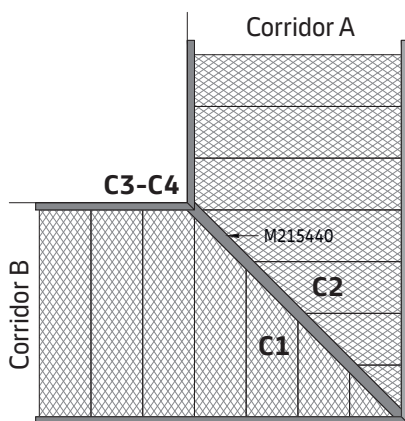

The L-Profile forms the transition and is attached diagonally, corridor A and B are equivalent. With this solution, the profile must be fitted exactly. Various details are possible. Panels get cut to size on site.

MESH F-L 601 / MESH F-L 601 MT
D03.400

Detail C

D1 - Transition with perimeter trims (e.g. with MESH F-L 601)

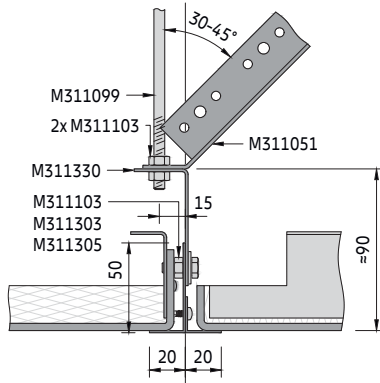

D2 - Transition with shadowline trims (e.g. with MESH F-L 601)

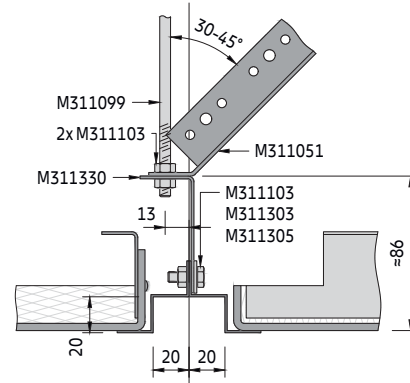

As a transition, two perimeter trims can be fastened back to back. One of the perimeter trims forms an extension and spans the width of the corridor, the second is attached to it with self-drilling screws. The self-drilling screws are set at a maximum distance of 300 mm. The perimeter trims are suspended from the plenum with attachment brackets and threaded rods at a distance of max. 600 mm. The distance from the corner to the first suspension point should be max. 200 mm. In order to keep the perimeter trims in position, an angle bracing is attached using a primary angle at an angle of 30 to 45°. This is attached to the plenum at the top with an attachment bracket, using a M6 bolt. The end is cut at the bottom and bent to the required angle and attached to the perimeter trims with an M6 bolt.

D3 - Transition with 2x perimeter trim, example with RA 1 / RA 2

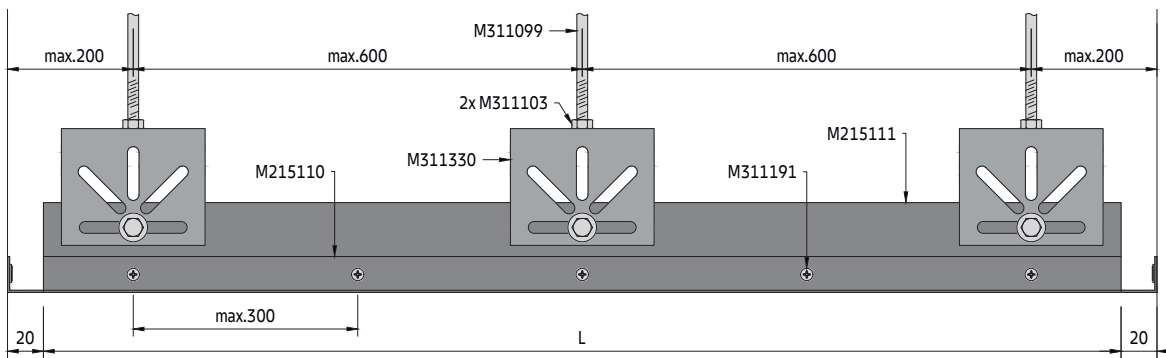

MESH F-L 601 / MESH F-L 601 MT
D03.400

D4 - Transition example with RA 1 / RA 2

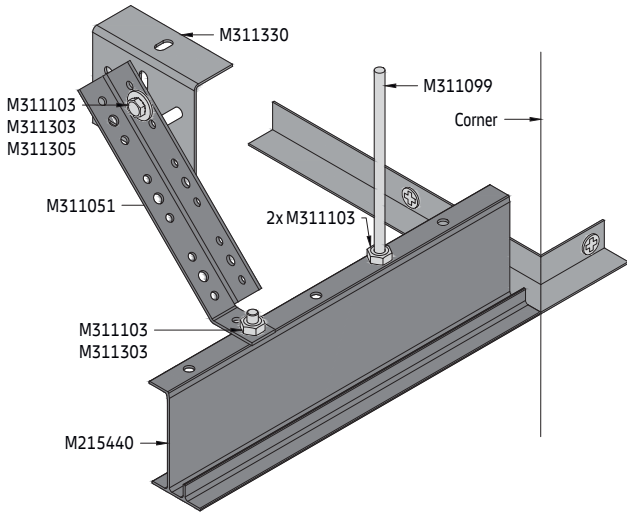

D5 - Transition example with RA 3

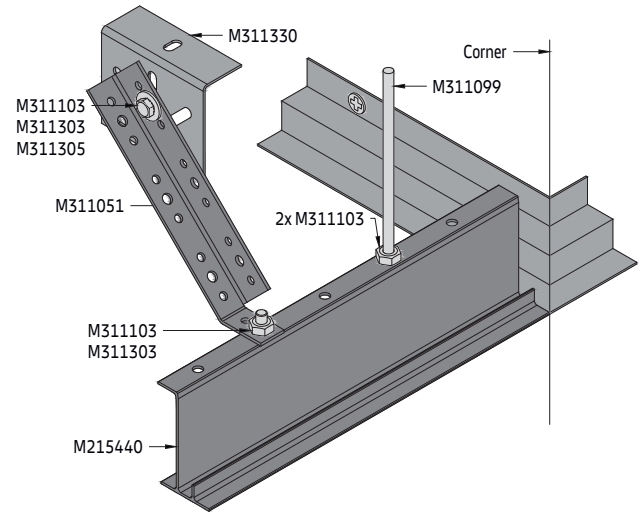

T-junction

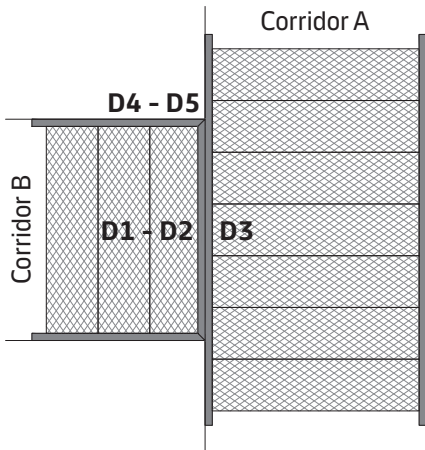

Corridor A runs through, corridor B connects to it and forms a T-junction.

Corner 1 with RA 1

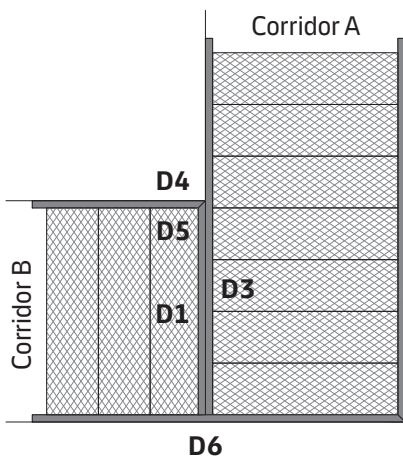

Corridor A runs to the end, corridor B connects to it and forms a transition. This solutions is recommended for L-perimeter trims.

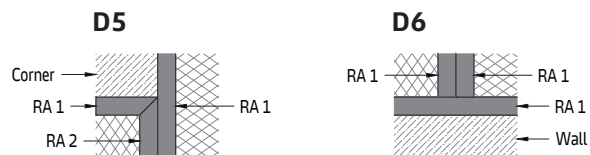

MESH F-L 601 / MESH F-L 601 MT
D03.400

Corner 2 with RA 3

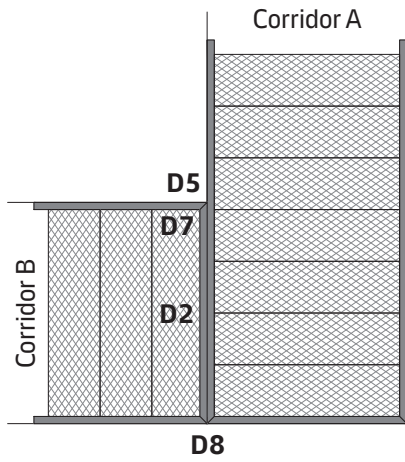

Corridor A runs to the end, corridor B connects to it and forms a transition. This solution is recommended for shadowline perimeter trims. Each corridor is completely framed by a shadowline perimeter trim.

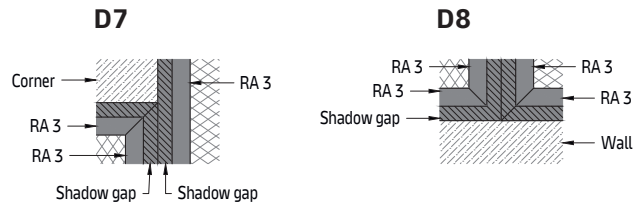

MESH F-Clip

Wall bracket + half DP12 A-Bar secondary grid
Concealed grid corridor solution for indoor applications

General information

- Concealed clip-in grid system for corridors
- Wall bracket (black coated) and half DP12 A-Bar made of galvanised steel
- Typical ceiling weight 9.5 - 22.0 kg/m² (indicative value for panels, without additional load)
- With variable shadow gap along the walls
- Panels are easily installed and fully demountable
- Optional security clips available

Isometric view

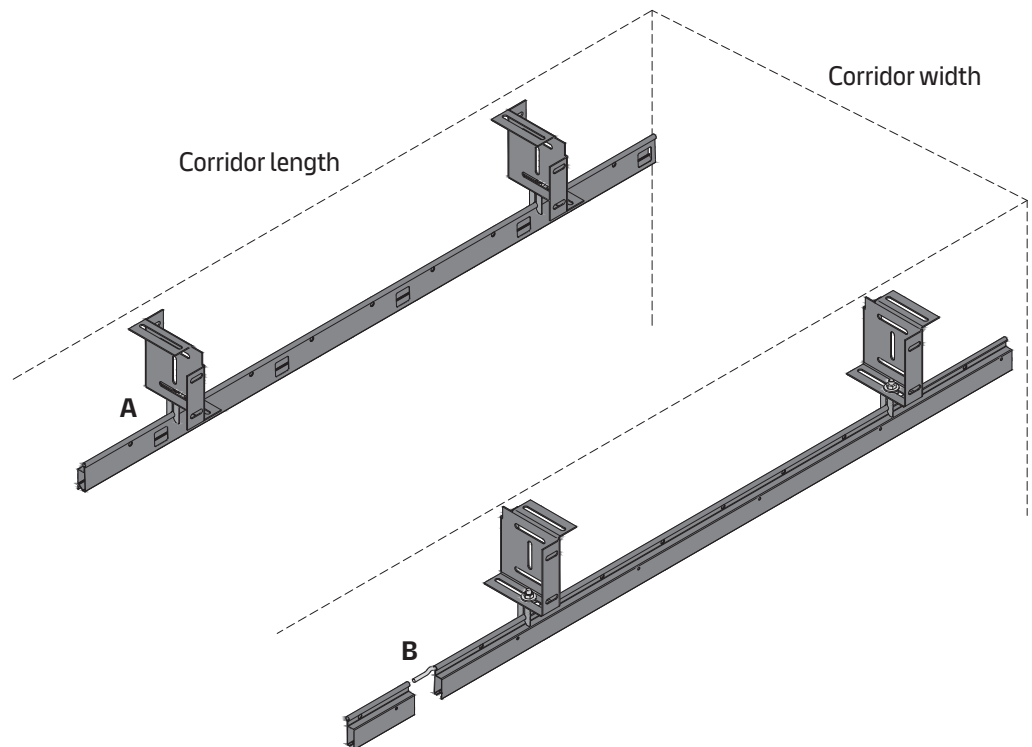

Vario Design layout options

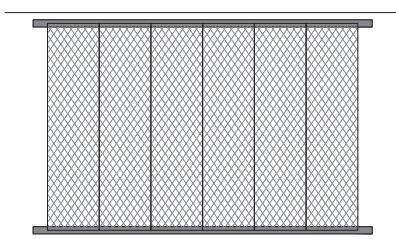

Wall bracket

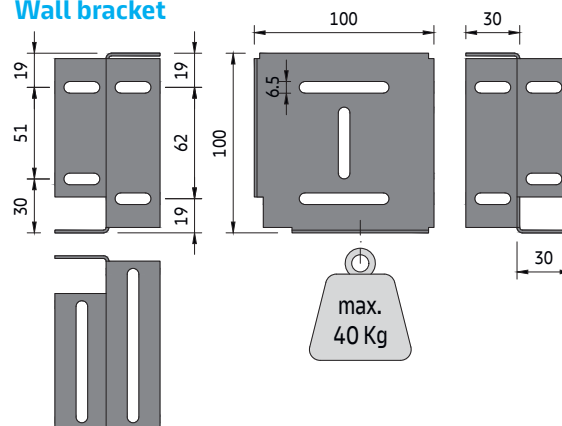

Section C

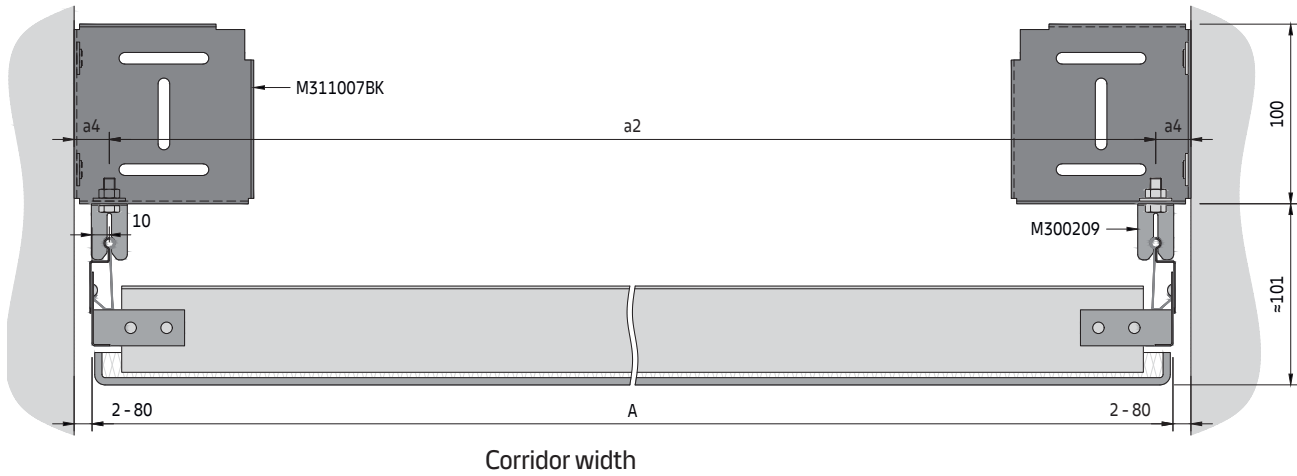

Section D

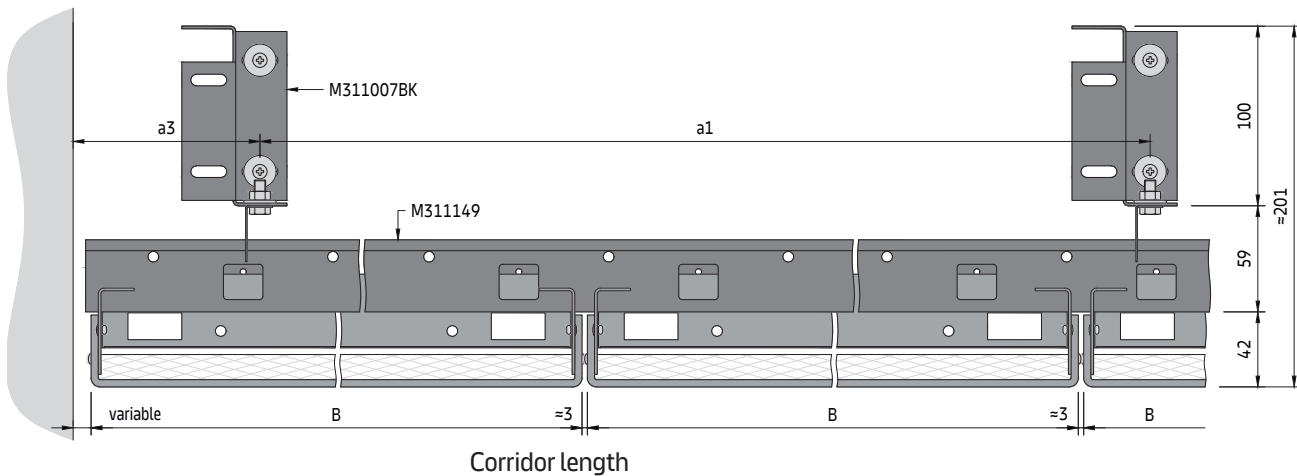

The panels should be installed with a ≈ 3 mm open gap on the long side, which enables installation.

Secondary grid components

Standard components

- M311007BK Wall bracket
- M311149 Half DP12 A-Bar
- M300138 Connection pin for DP12 A-Bar
- M300209 Hanger for DP12 A-Bar
- M311103 Hexagonal nut M6
- M311105 Washer
- M311303 Hexagonal bolt M6 x 16 mm

Optional components

- M311046 Extraction tool
- M300106 Security clip
- M311051 Primary angle 3000 x 27 x 22 mm
- M311099 Threaded rod M6 x 1000 mm
- M215110 RA 1 perimeter trim 4000 x 20 x 20 mm RAL 9010

Half DP12 A-Bar secondary grid

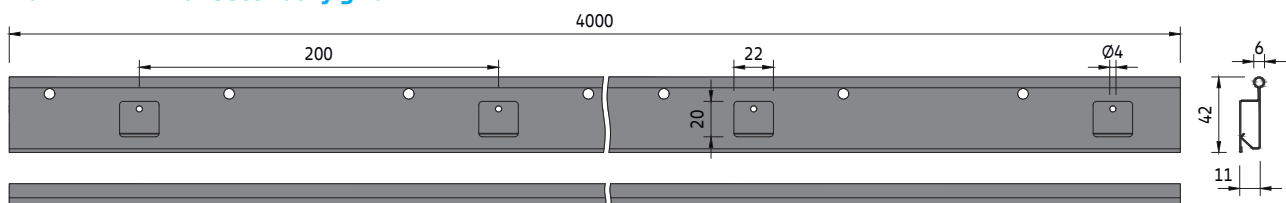

MESH F-Clip
D03.401

Spacing

a2 [mm]	System without additional load	System with additional load +4 kg/m ²
	a1 [mm]	a1 [mm]
1000	1350	1200
1050	1350	1200
1100	1300	1150
1150	1250	1150
1200	1250	1100
1250	1200	1100
1300	1200	1050
1350	1150	1050
1400	1150	1050
1450	1150	1000
1500	1100	1000
1550	1100	950
1600	1100	950
1650	1050	950
1700	1050	950
1750	1050	900
1800	1000	900
1850	1000	900
1900	1000	900
1950	950	850
2000	950	850
2050	950	850
2100	950	850
2150	950	850
2200	900	800
2250	900	800
2300	900	800
2350	900	800
2400	900	800
2450	850	800
2500	850	750

Parameters

- a1 Distance of wall brackets
- a2 Distance between half DP12 A-Bars fixing points = A - 20 mm
- a3 Distance from wall = max. 200 mm
- a4 Variable distance from wall to half DP12 A-Bar fixing point
- M Module size = panel length / panel width + ≈3 mm gap
- A Panel length = min. 597 / max. 2500 mm *
- B Panel width = min. 247 / max. 600 mm *

* The dimensions depend on the chosen system and mesh pattern

Typical grid layout

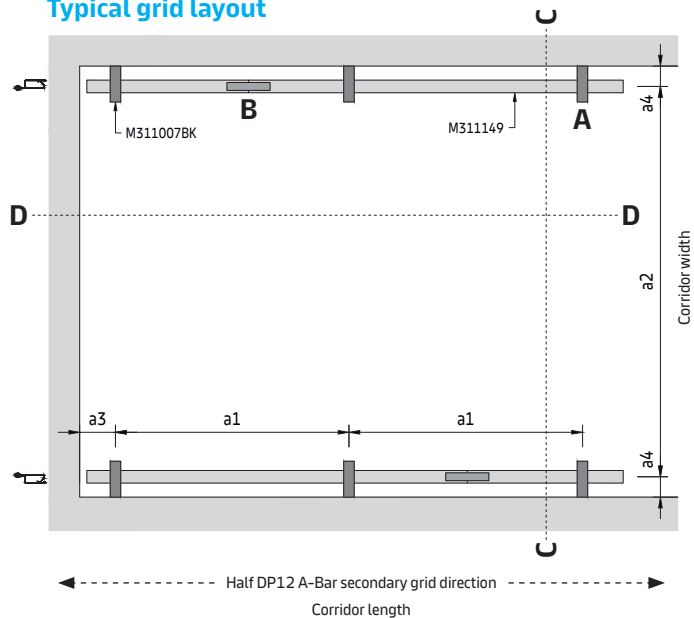

To determine suspension layout

The panel length (A) of the requested ceiling -20 mm is equal to the distance between the half DP12 A-Bar centres (a2).

On the appropriate spacing table, read down the column headed (a2) to the required panel length then read across to determine the wall bracket spacing (a1).

The shown values are maximum allowed distances and can be reduced but not exceeded.

MESH F-Clip
D03.401

Detail A

Hanger installation

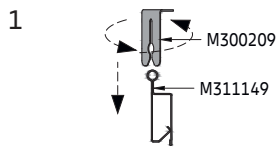

The hanger for half DP12 A-Bar is made of spring steel and is therefore elastic. It is twisted on the half DP12 A-Bar from above. Then it can be slid to the correct position.

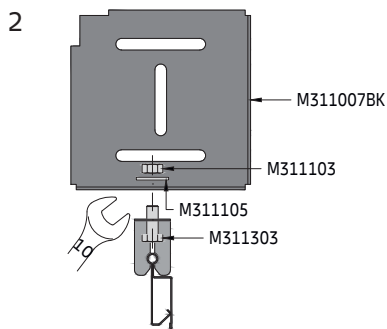

Fix the half DP12 A-Bar with fasteners below the wall bracket.

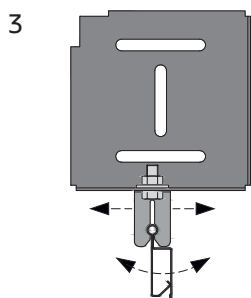

The half DP12 A-Bar is now locked in position. Due to the round head of the half DP12 A-Bar, it can swing. This is important because it allows any tolerances to be compensated.

Detail B

Splice connection

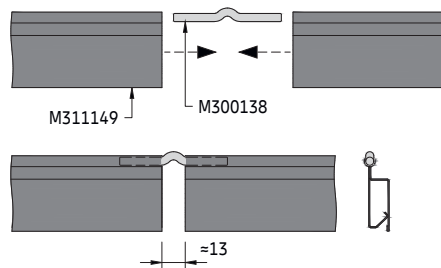

Insert the connection pin at the ends of the half DP12 A-Bars and connect them. There is a gap between the half DP12 A-Bars. The half DP12 A-Bars must be aligned so that the joint is not in the same place as the pips on the panels.

Detail C

Panel insertion

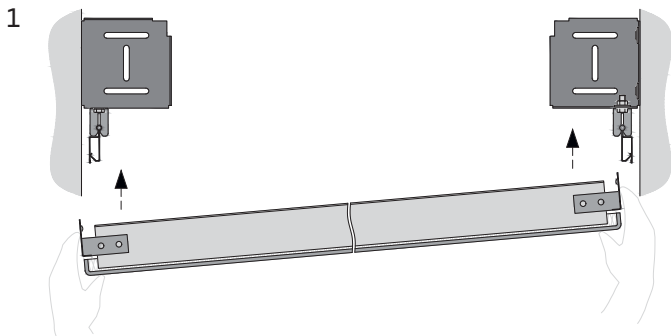

Take the panel and carefully insert it into the half DP12 A-Bars from below. All panels feature a double row of pips. The upper pip is inserted into the half DP12 A-Bar, the lower one serves as a stop. Care is required when installing panels. Always press along the edges with the pips and never on the transverse sides, otherwise the panels may be damaged. The panels should always be laid in such a way that the Window hooks point in the same direction.

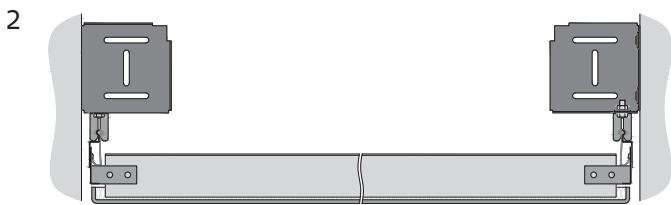

The panels are correctly inserted when all four corners are flush with the neighbouring panels. The panels are designed to match the half DP12 A-Bar. If third party profiles are used there is a high probability the tiles will not be correctly inserted.

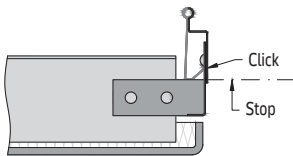

Panel extraction

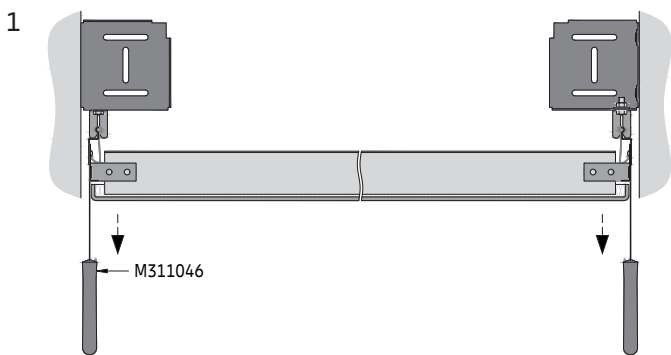

The panels are designed in such a way that the extraction tool can only be inserted in the designated places so that it clicks into place. There is a rectangular cut-out on the panels. It is therefore important that the appropriate extraction tool is used. This prevents damage to the panels. Insert on one side first and pull down with a gentle tug, followed by the opposite side.

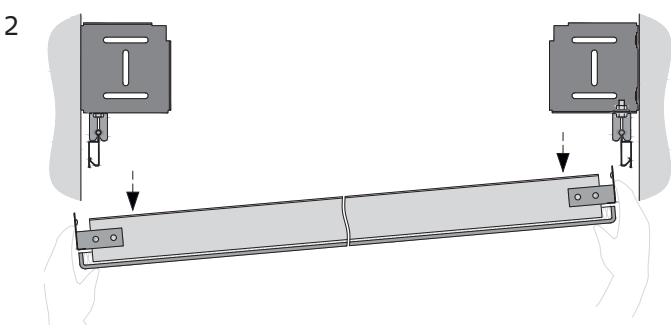

Remove it downwards and store the panel in a safe place so that it cannot be damaged.

MESH F-Clip

D03.401

Detail D

Optional security clip

The security clip serves to secure the panels and prevents them from being removed.

Panel locking

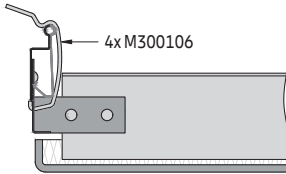

The panels feature an embossing on the sides with the pips, allowing the security clip to be securely fixed. First hook the security clip into the panel and then slip the upper end over the half DP12 A-Bar. Four security clips are required per panel.

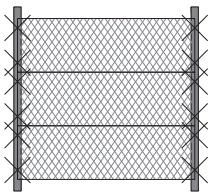

Either individual panels or the entire ceiling can be secured. The panels are inserted and secured immediately. The last panel cannot be locked.

Detail E

Optional perimeter trim for cut panels

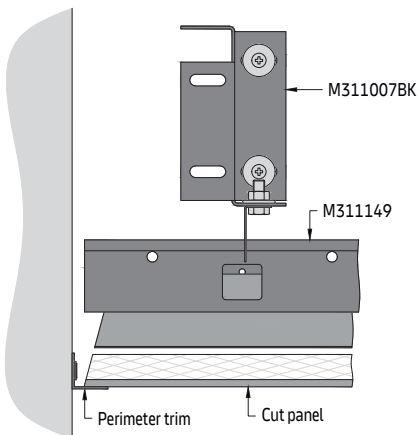

The last panel at the end of the corridor can be made to measure. A cost-effective alternative is to use a perimeter trim. This allows panels to be cut to size on site. See separate document for perimeter trim options.

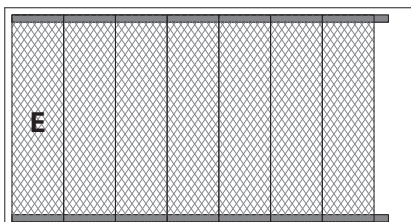

MESH F-Clip
D03.401

Detail F

Optional perimeter trim for shadow gap

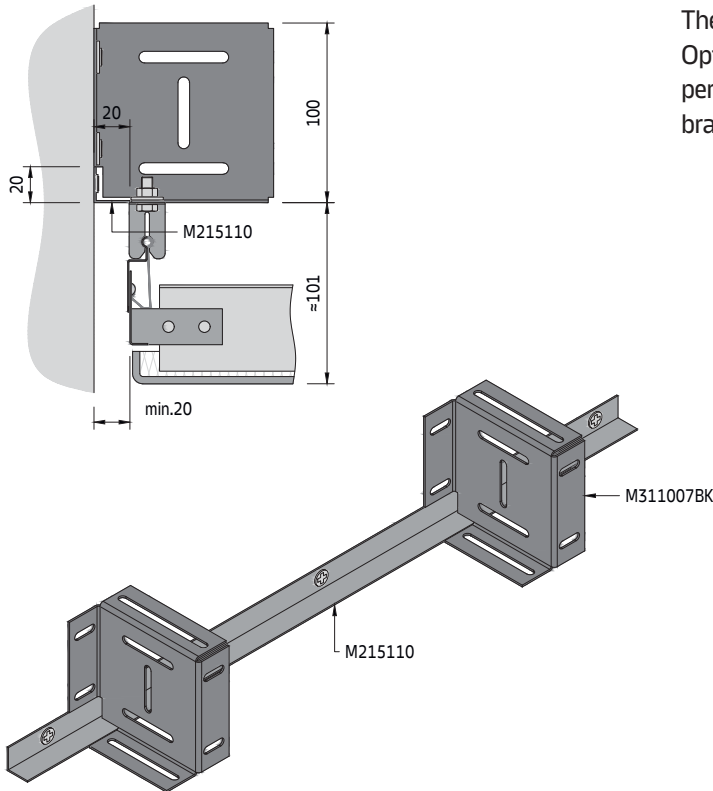

The shadow gap remains open in the standard version. Optionally, this can be covered with a perimeter trim. The perimeter trim is attached at the correct height so that the wall brackets can be placed on it and then attached to the wall.

Material required per m² (no waste included)

System without additional load [pcs/m²]

Components	a2 [mm]	1200	1600	1800	2000	2200	2500	2500
M300138	Connection pin for DP12 A-Bar	0.40	0.35	0.31	0.27	0.25	0.23	0.20
M300209	Hanger for DP12 A-Bar	1.36	1.22	1.18	1.10	1.05	1.01	0.90
M311007BK	Wall bracket	1.36	1.22	1.18	1.10	1.05	1.01	0.90
M311103	Hexagonal nut M6	1.36	1.22	1.18	1.10	1.05	1.01	0.90
M311105	Washer	1.36	1.22	1.18	1.10	1.05	1.01	0.90
M311149	Half DP12 A-Bar	0.40	0.35	0.30	0.27	0.24	0.22	0.20
M311303	Hexagonal bolt M6 x 16 mm	1.36	1.22	1.18	1.10	1.05	1.01	0.90

The shown quantities are theoretical and based on an ideal layout, without considering the actual room layout. The ideal layout is based on a calculation 100 m². This calculation does not allow any damage, spare nor wastage. The final quantities and type of suspension have to be checked before ordering. Soffit and wall fixings by others. Not including optional items and extraction tools.

MESH F-Clip
D03.401

Detail G

Suspension option by double threaded rod

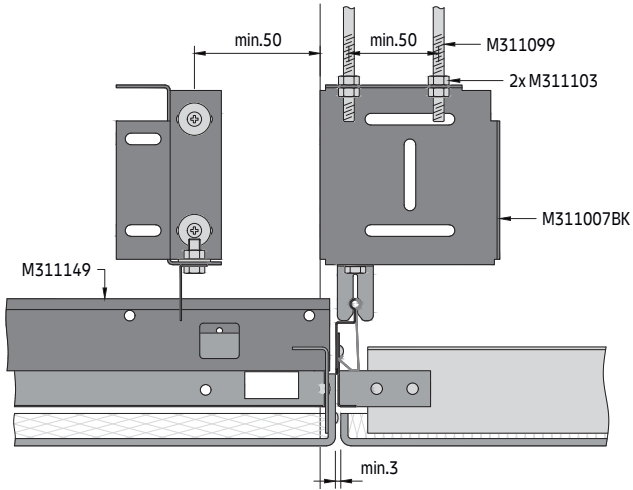

Suspension option by threaded rod with angle bracing

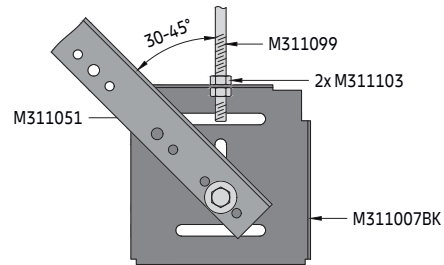

In these situations, the wall bracket can be suspended either with two threaded rods or one threaded rod and fixed by an angle bracing.

T-junction

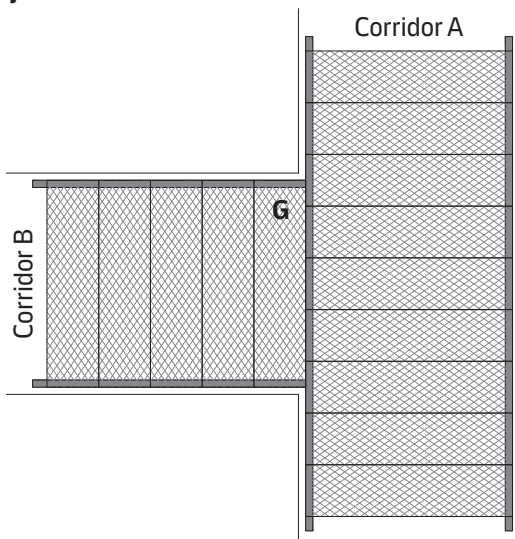

Corridor A runs through, corridor B connects to it and forms a T-junction.

Corner

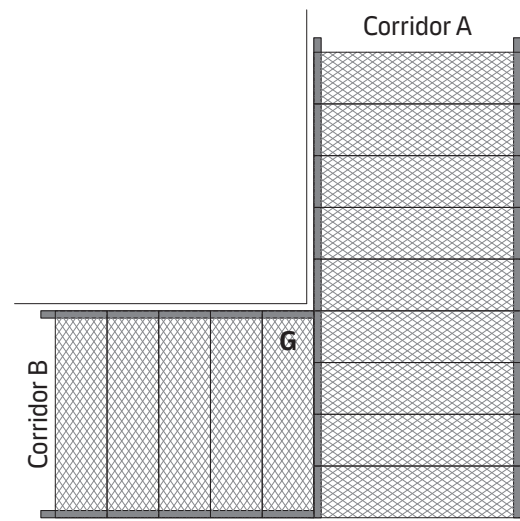

Corridor A runs to the end, corridor B connects to it and forms a transition.

MESH F-Clip

Wall bracket + DP12 A-Bar secondary grid
Concealed grid corridor solution for indoor applications

General information

- Concealed clip-in grid system for corridors
- Wall bracket (black coated) and DP12 A-Bar made of galvanised steel
- Typical ceiling weight 9.5 - 22.0 kg/m² (indicative value for panels, without additional load)
- With variable shadow gap along the walls
- Panels are easily installed and fully demountable
- Optional security clips available

Isometric view

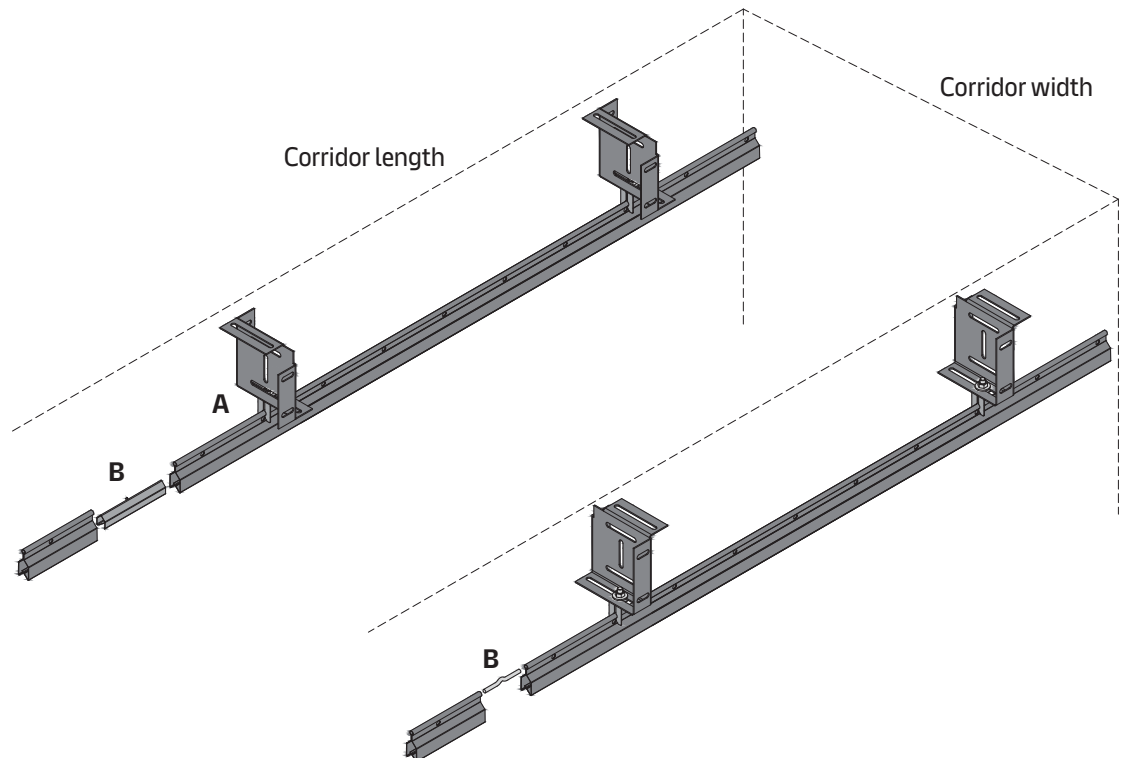

Vario Design layout options

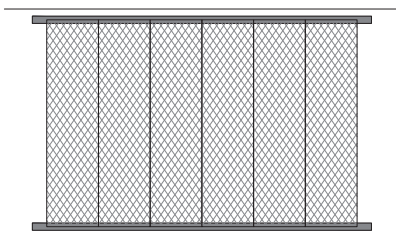

Wall bracket

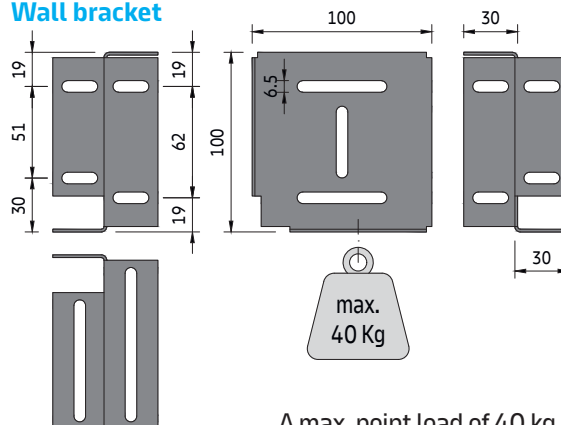

A max. point load of 40 kg is permitted.

MESH F-Clip
D03.401.1

Section C

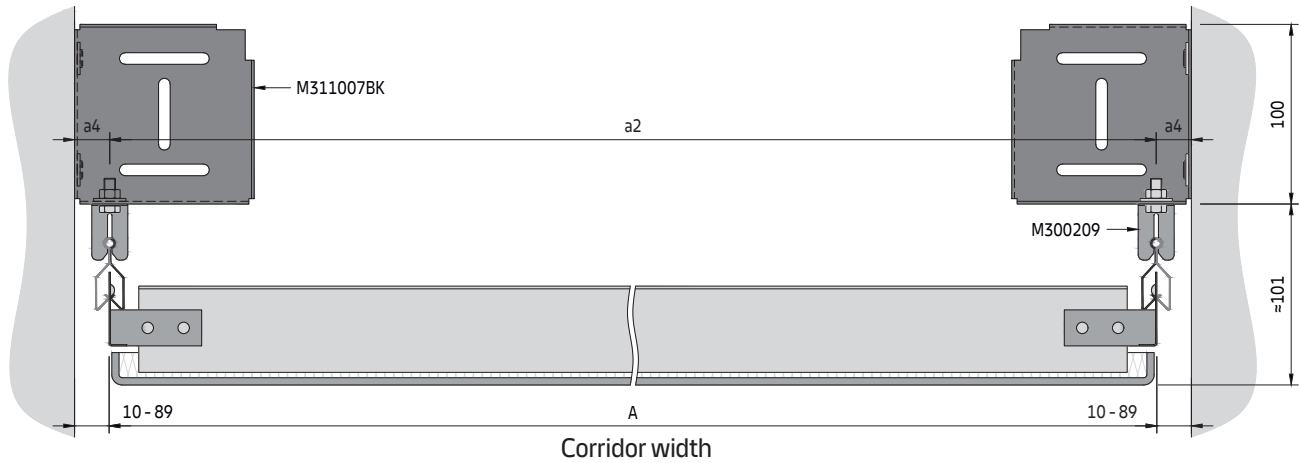

Section D

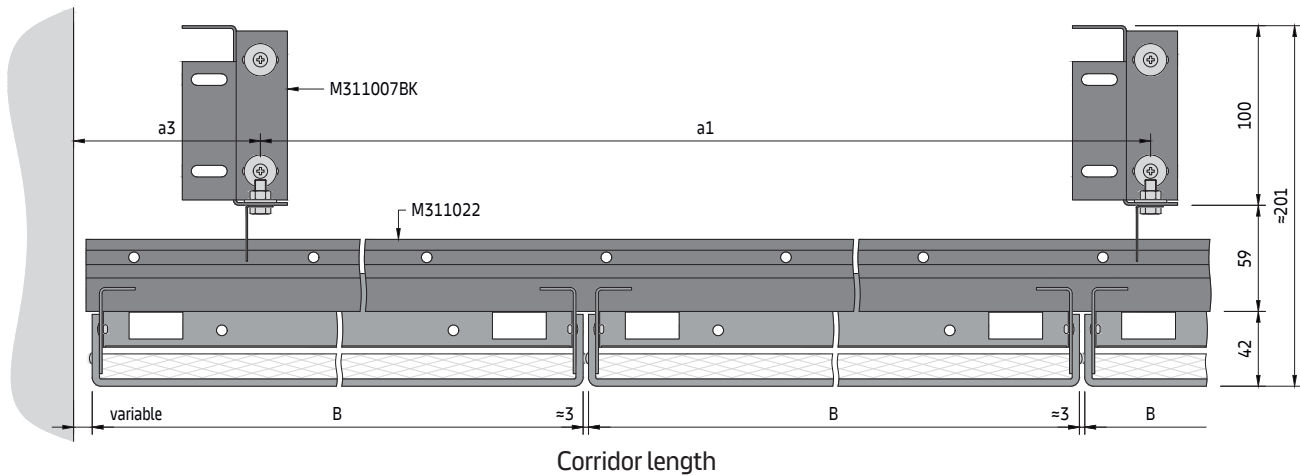

The panels should be installed with a ≈ 3 mm open gap on the long side, which enables installation.

Secondary grid components

Standard components:

- M311007BK Wall bracket
- M300138 Connection pin for DP12 A-Bar
- M300209 Hanger for DP12 A-Bar
- M311022 DP12 A-Bar
- M311103 Hexagonal nut M6
- M311105 Washer
- M311303 Hexagonal bolt M6 x 16 mm

Optional components

- M300106 Security clip
- M311023 Splice connector for DP12 A-Bar
- M311046 Extraction tool
- M311051 Primary angle 3000 x 27 x 22 mm
- M311099 Threaded rod M6 x 1000 mm

DP12 A-Bar secondary grid

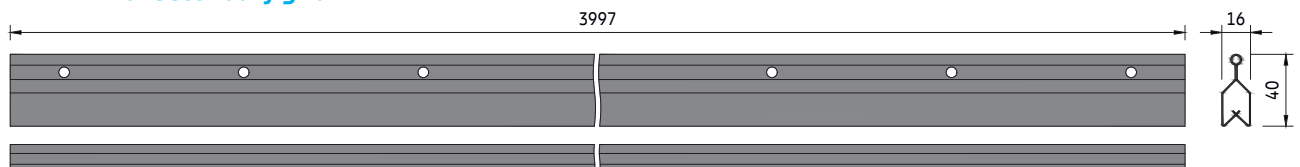

MESH F-Clip
D03.401.1

Spacing

	System without additional load	System with additional load +4 kg/m ²
a2 [mm]	a1 [mm]	a1 [mm]
1000	1550	1400
1050	1500	1350
1100	1500	1350
1150	1450	1350
1200	1450	1300
1250	1450	1300
1300	1400	1300
1350	1400	1250
1400	1400	1250
1450	1350	1200
1500	1350	1200
1550	1350	1200
1600	1350	1200
1650	1300	1200
1700	1300	1150
1750	1300	1150
1800	1300	1150
1850	1250	1150
1900	1250	1150
1950	1250	1100
2000	1250	1100
2050	1250	1100
2100	1200	1100
2150	1200	1100
2200	1200	1100
2250	1200	1050
2300	1200	1050
2350	1200	1050
2400	1150	1050
2450	1150	1050
2500	1150	1050

Parameters

- a1 Distance of wall brackets
- a2 Distance between DP12 A-Bars fixing points
- a3 Distance from wall = max. 200 mm
- a4 Variable distance from wall to DP12 A-Bar fixing point
- M Module size = panel length / panel width + ≈ 3 mm gap
- A Panel length = min. 597 / max. 2500 mm *
- B Panel width = min. 247 / max. 600 mm *

* The dimensions depend on the chosen system and mesh pattern

Typical grid layout

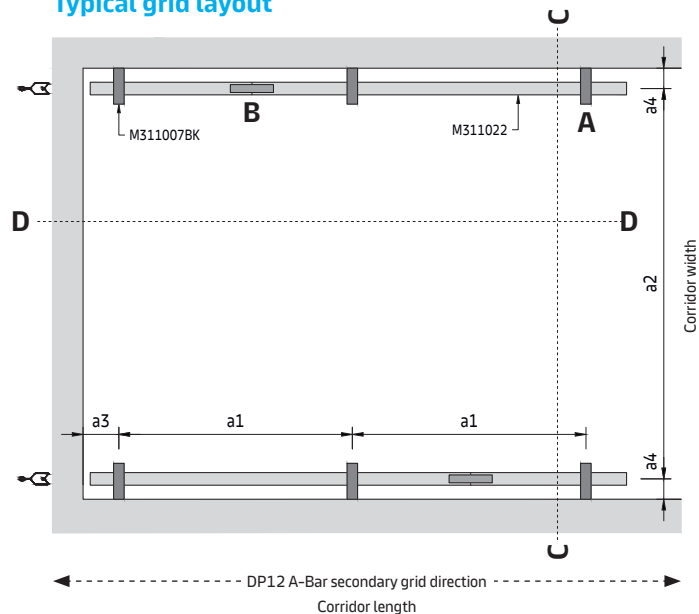

To determine suspension layout

The panel length (A) of the requested ceiling is equal to the distance between the DP12 A-Bar centres (a2).

On the appropriate spacing table, read down the column headed (a2) to the required panel length then read across to determine the wall bracket spacing (a1).

The shown values are maximum allowed distances and can be reduced but not exceeded.

MESH F-Clip
D03.401.1

Detail A

Hanger installation

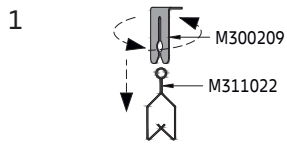

The hanger for DP12 A-Bar is made of spring steel and is therefore elastic. It is twisted on the DP12 A-Bar from above. Then it can be slid to the correct position.

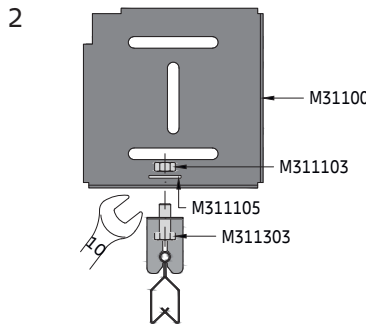

Fix the DP12 A-Bar with fasteners below the wall bracket.

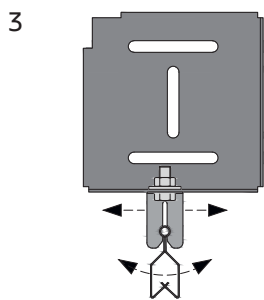

The DP12 A-Bar is now locked in position. Due to the round head of the DP12 A-Bar, it can swing. This is important because it allows any tolerances to be compensated.

Detail B

Splice connection

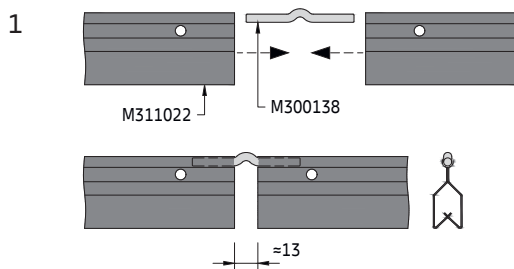

Insert the connection pin at the ends of the DP12 A-Bars and connect them. There is a gap between the DP12 A-Bars. The DP12 A-Bars must be aligned so that the joint is not in the same place as the pips on the tiles / panels.

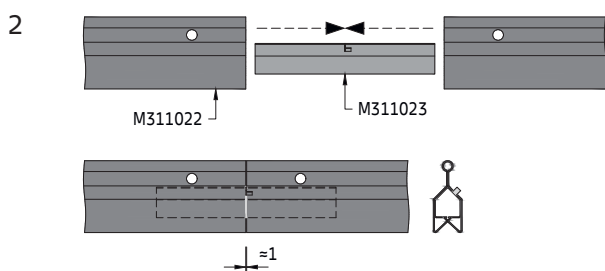

Optionally, the splice connector for DP12 A-Bar can be used. This is inserted at the ends of the DP12 A-Bars and an almost seamless connection is created.

Detail C

Panel insertion

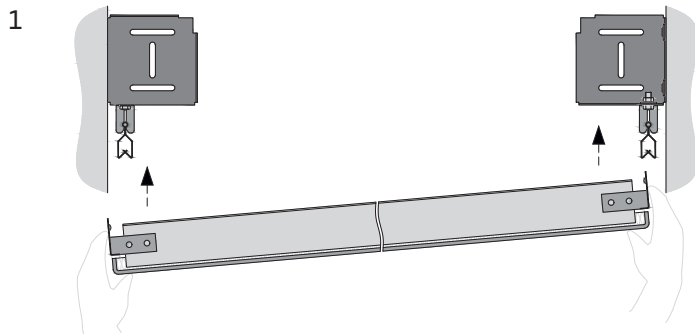

Take the panel and carefully insert it into the DP12 A-Bars from below. All panels feature a double row of pips. The upper pip is inserted into the DP12 A-Bar, the lower one serves as a stop. Care is required when installing panels. Always press along the edges with the pips and never on the transverse sides, otherwise the panels may be damaged. The panels should always be laid in such a way that the Window hooks point in the same direction.

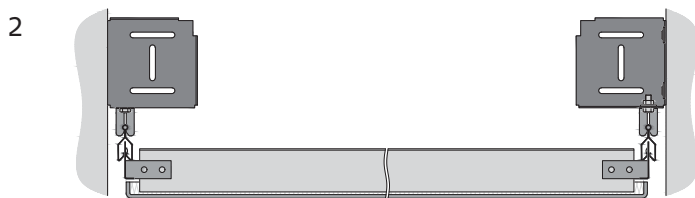

The panels are correctly inserted when all four corners are flush with the neighbouring panels. The panels are designed to match the DP12 A-Bar. If third party profiles are used there is a high probability the tiles will not be correctly inserted.

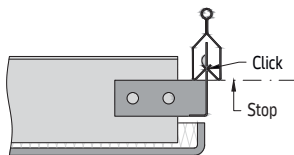

Panel extraction

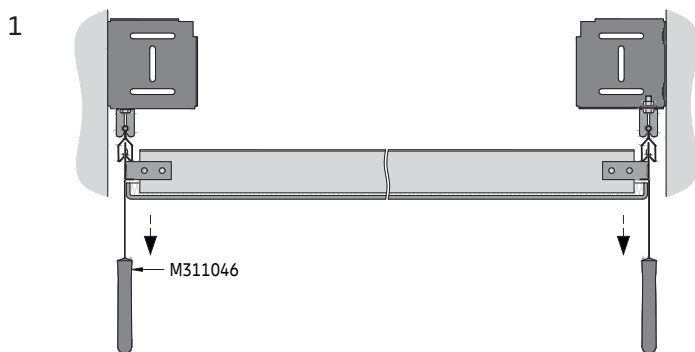

The panels are designed in such a way that the extraction tool can only be inserted in the designated places so that it clicks into place. There is a rectangular cut-out on the panels. It is therefore important that the appropriate extraction tool is used. This prevents damage to the panels. Insert on one side first and pull down with a gentle tug, followed by the opposite side.

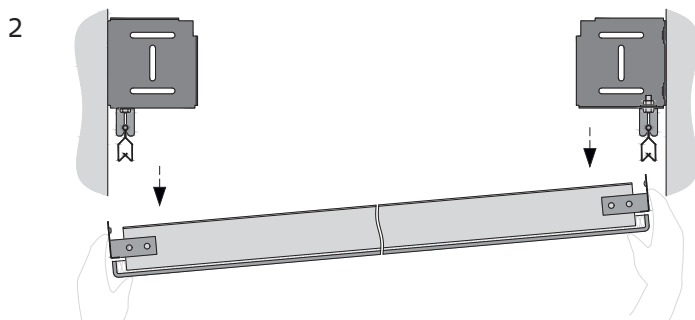

Remove it downwards and store the panel in a safe place so that it cannot be damaged.

MESH F-Clip

D03.401.1

Detail D

Optional security clip

The security clip serves to secure the panels and prevents them from being removed.

Panel locking

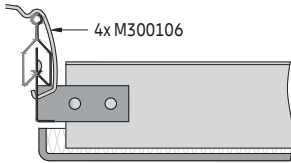

The panels have, on the sides where the pips are, an embossing where the security clip can be fixed. First hook the security clip into the panel and then slip the upper end over the half DP12 A-Bar. Four security clips are required per panel.

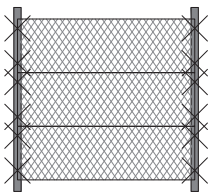

Either individual panels or the entire ceiling can be secured. The panels are inserted and secured immediately. The last panel cannot be locked.

Detail E

Optional perimeter trim for cut panels

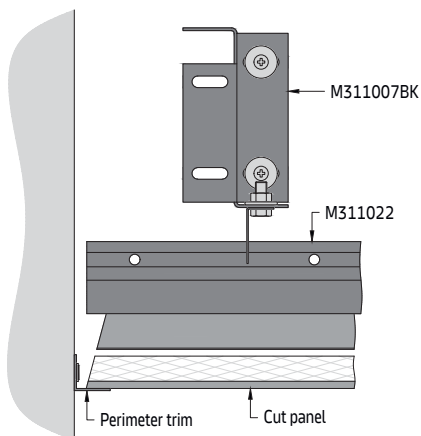

The last panel at the end of the corridor can be made to measure. A cost-effective alternative is to use a perimeter trim. This allows panels to be cut to size on site. See separate document for perimeter trim options.

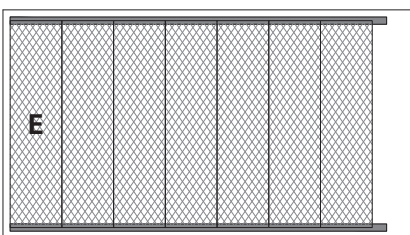

Detail F

Suspension option by double threaded rod

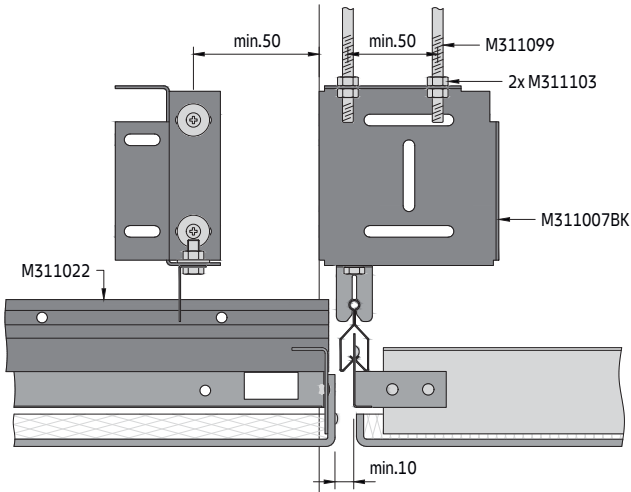

Suspension option by threaded rod with angle bracing

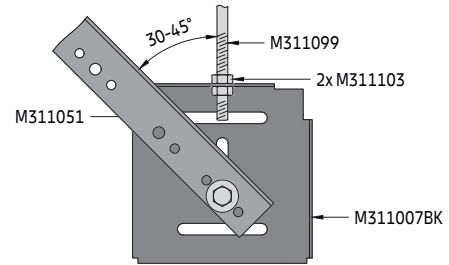

In these situations, the wall bracket can be suspended either with two threaded rods or one threaded rod and fixed by an angle bracing.

T-junction

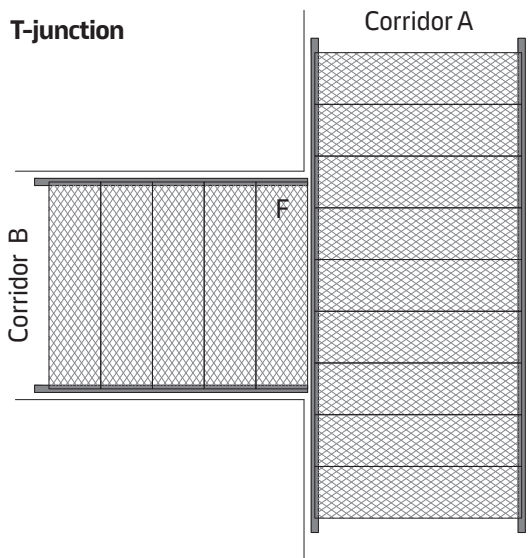

Corridor A runs through, corridor B connects to it and forms a T-junction.

Corner

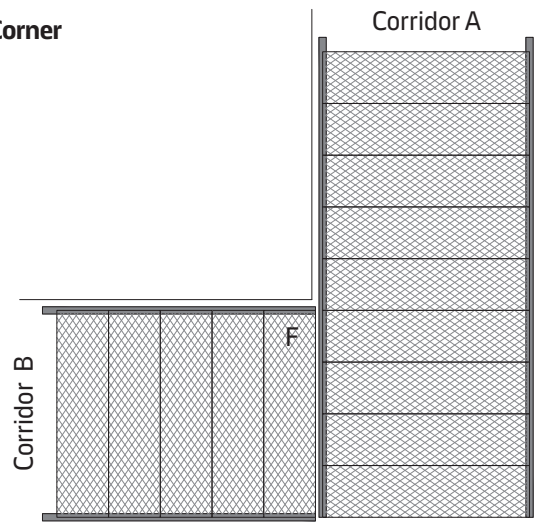

Corridor A runs to the end, corridor B connects to it and forms a transition.

MESH F-Clip

D03.401.1

Material required per m² (no waste included)

System without additional load [pcs/m²]

Components		a2 [mm]	1200	1600	1800	2000	2200	2500	2500
M300138	Connection pin for DP12 A-Bar		0.42	0.36	0.31	0.28	0.25	0.23	0.20
M300209	Hanger for DP12 A-Bar		1.14	1.02	0.93	0.86	0.81	0.77	0.71
M311007BK	Wall bracket		1.14	1.02	0.93	0.86	0.81	0.77	0.71
M311022	DP12 A-Bar		0.42	0.36	0.31	0.28	0.25	0.23	0.20
M311103	Hexagonal nut M6		1.14	1.02	0.93	0.86	0.81	0.77	0.71
M311105	Washer		1.14	1.02	0.93	0.86	0.81	0.77	0.71
M311303	Hexagonal bolt M6 x 16 mm		1.14	1.02	0.93	0.86	0.81	0.77	0.71

The shown quantities are theoretical and based on an ideal layout, without considering the actual room layout. The ideal layout is based on a calculation 100 m². This calculation does not allow any damage, spare nor wastage. The final quantities and type of suspension have to be checked before ordering. Soffit and wall fixings by others. Not including optional items and extraction tools.

MESH F-H 600 / MESH F-H 600 MT

Wall bracket + J-Bar secondary grid

Concealed grid corridor solution for indoor applications

General information

- Concealed hook-on grid system for corridors
- Wall bracket (black coated) and J-Bar made of galvanised steel
- Typical ceiling weight 11.5 - 24.0 kg/m² (indicative value for panels, without additional load)
- With variable shadow gap along the walls
- Panels are easily installed and fully demountable
- Optional security brackets available

Isometric view

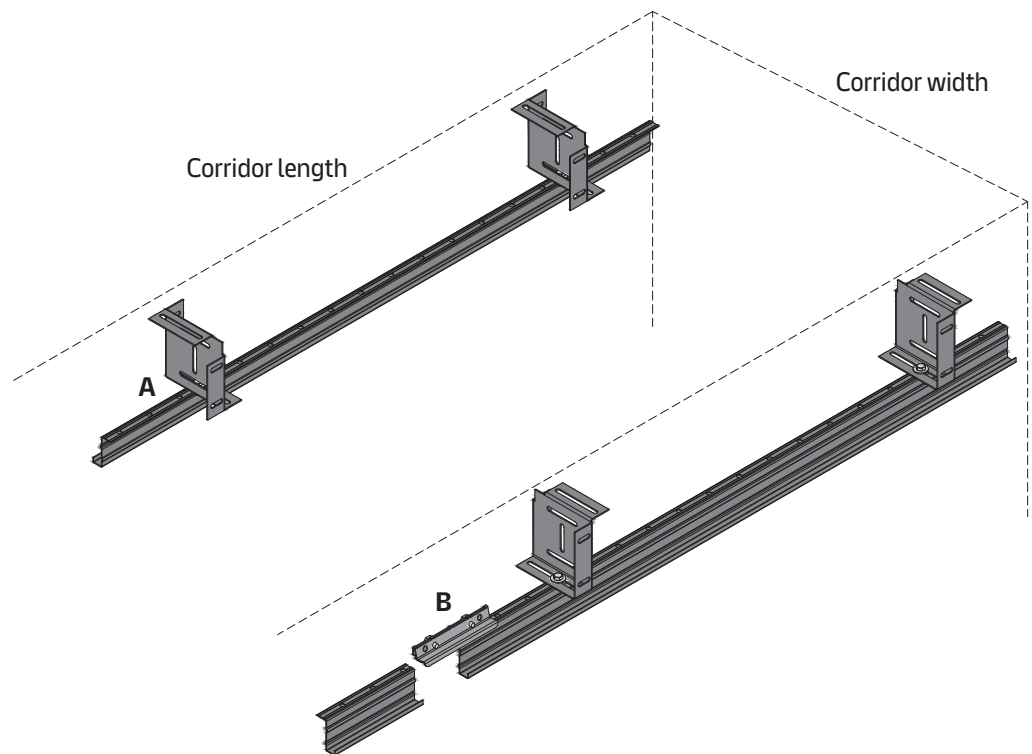

Vario Design layout options

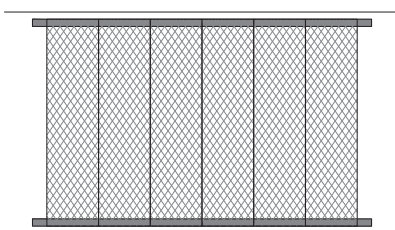

Wall bracket

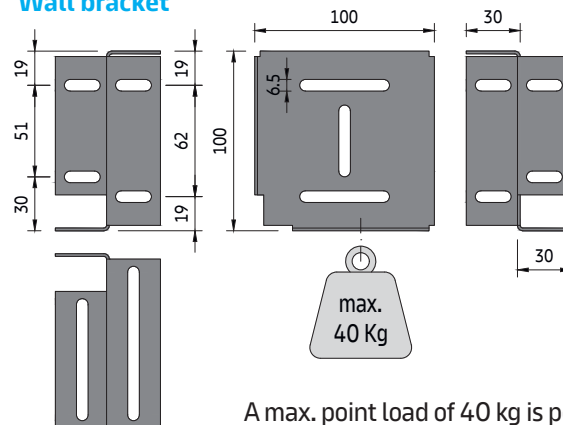

A max. point load of 40 kg is permitted.

MESH F-H 600 / MESH F-H 600 MT
D03.402

Section C (MESH F-H 600)

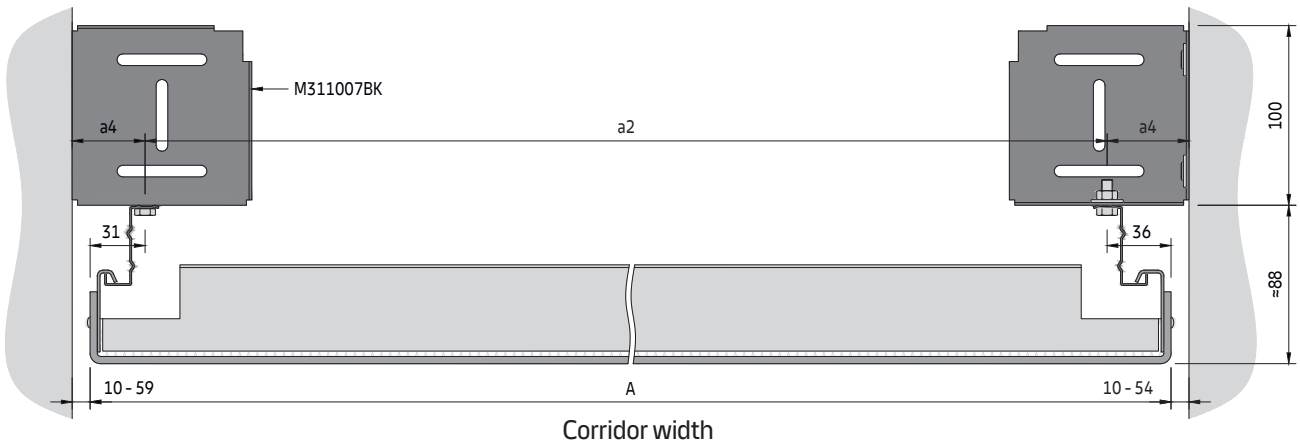

Section C (MESH F-H 600 MT)

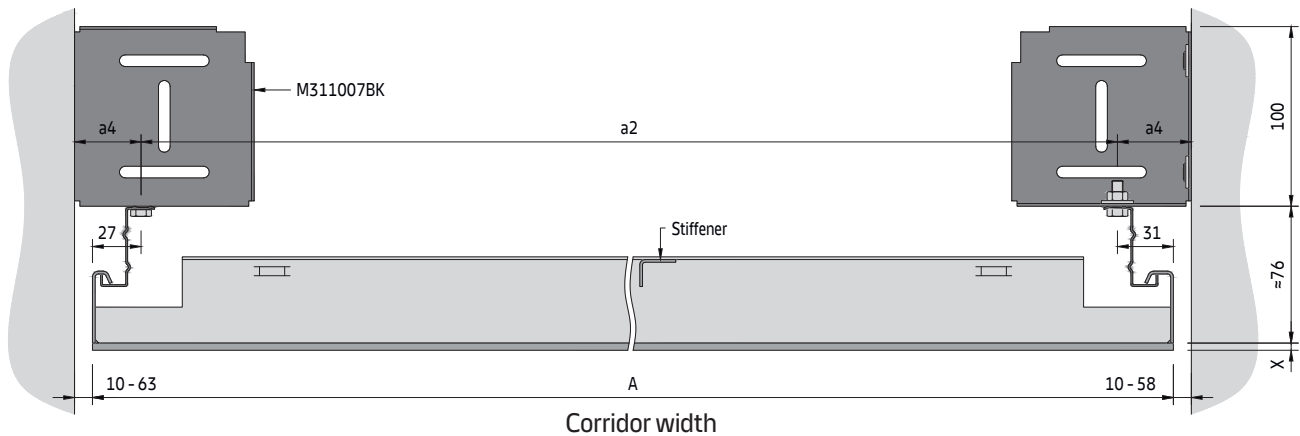

Panels >2000 mm length with additional welded stiffener.

Secondary grid components

Standard components:

- M311007BK Wall bracket
- M300026 J-Bar
- M300307 Splice connector for J-Bar
- M311103 Hexagonal nut M6
- M311105 Washer
- M311303 Hexagonal bolt M6 x 16 mm

Suspension option F2

- M311218 Security bracket
- M311191 Self-drilling screw 3.5 x 9.5 mm
- M311051 Primary angle 3000 x 27 x 22 mm
- M311099 Threaded rod M6 x 1000 mm
- M215110 RA 1 perimeter trim 4000 x 20 x 20 mm RAL 9010

J-Bar secondary grid

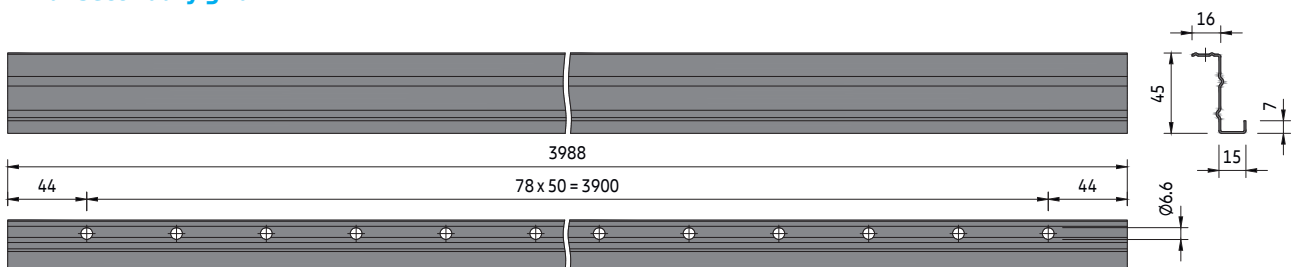

Section D (MESH F-H 600)

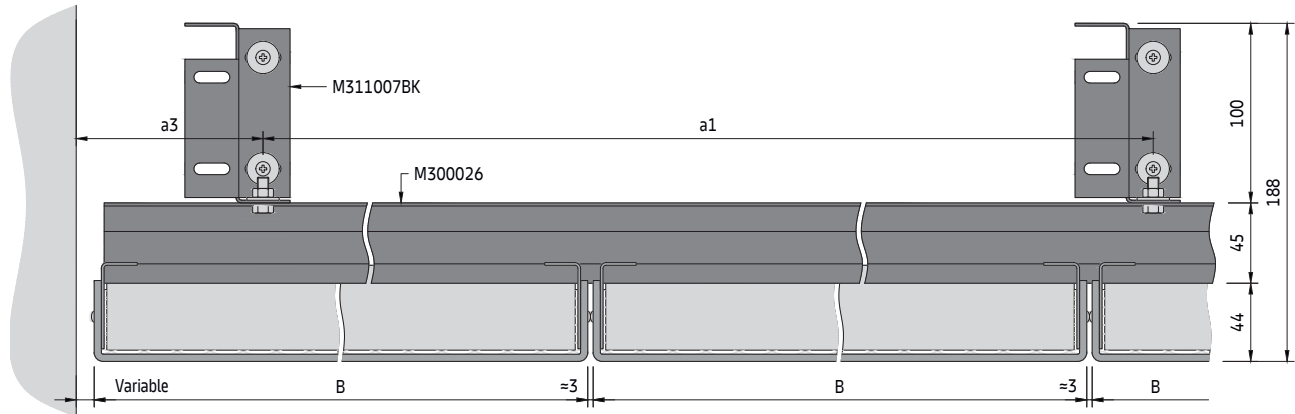

The panels should be installed with a ≈ 3 mm open gap on the long side, which enables installation.

Section D (MESH F-H 600 MT)

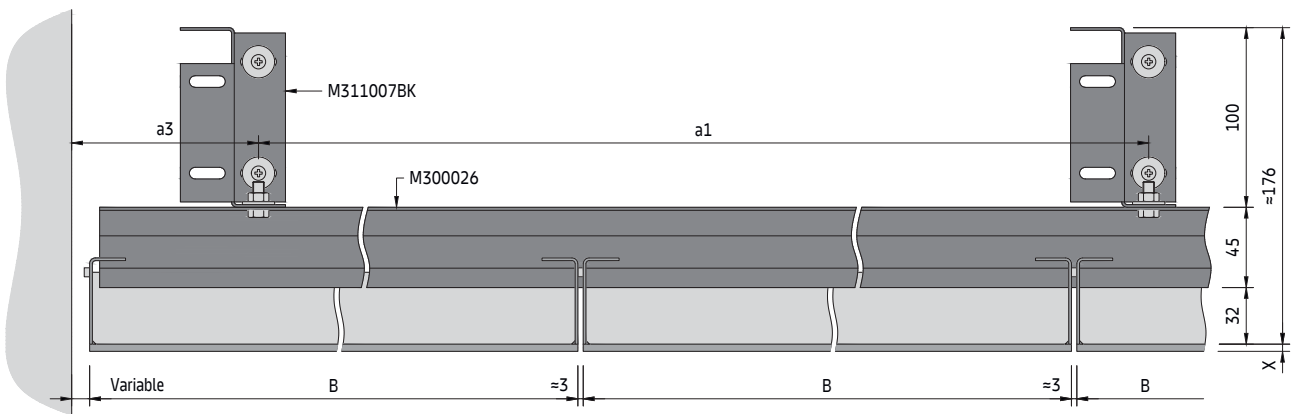

The panels come standard with a ≈ 3 mm spacer on the long side.

Material required per m² (no waste included)

System without additional load [pcs/m²]

Components	a2 [mm]	1200	1600	1800	2000	2200	2500
M300026	J-Bar	0.39	0.30	0.27	0.24	0.22	0.19
M300307	Splice connector for J-Bar	0.39	0.30	0.27	0.24	0.22	0.20
M311007BK	Wall bracket	1.02	0.90	0.87	0.82	0.78	0.72
M311103	Hexagonal nut M6	1.02	0.90	0.87	0.82	0.78	0.72
M311105	Washer	1.02	0.90	0.87	0.82	0.78	0.72
M311303	Hexagonal bolt M6 x 16 mm	1.02	0.90	0.87	0.82	0.78	0.72

The shown quantities are theoretical and based on an ideal layout, without considering the actual room layout. The ideal layout is based on a calculation 100 m². This calculation does not allow any damage, spare nor wastage. The final quantities and type of suspension have to be checked before ordering. Soffit and wall fixings by others.

Not including optional items and extraction tools.

MESH F-H 600 / MESH F-H 600 MT
D03.402

Spacing

	System without additional load	System with additional load +4 kg/m ²
a2 [mm]	a1 [mm]	a1 [mm]
1000	1550	1450
1050	1550	1400
1100	1500	1400
1150	1450	1350
1200	1450	1300
1250	1400	1250
1300	1350	1250
1350	1300	1200
1400	1300	1200
1450	1300	1200
1500	1300	1200
1550	1250	1150
1600	1250	1150
1650	1200	1150
1700	1200	1100
1750	1200	1100
1800	1150	1100
1850	1150	1050
1900	1150	1050
1950	1100	1050
2000	1100	1050
2050	1100	1000
2100	1100	1000
2150	1050	1000
2200	1050	1000
2250	1050	950
2300	1050	950
2350	1000	950
2400	1000	950
2450	1000	950
2500	1000	900

Parameters

- a1 Distance of wall brackets
- a2 Distance between J-Bars fixing points = A - 53 mm
- a3 Distance from wall = max. 200 mm
- a4 Variable distance from wall to J-Bar fixing point
- M Module size = panel length / panel width + ≈ 3 mm gap
- A Panel length = min. 597 / max. 2500 mm *
- B Panel width = min. 247 / max. 700 mm *
- X Material thickness

* The dimensions depend on the chosen system and mesh pattern

Typical grid layout

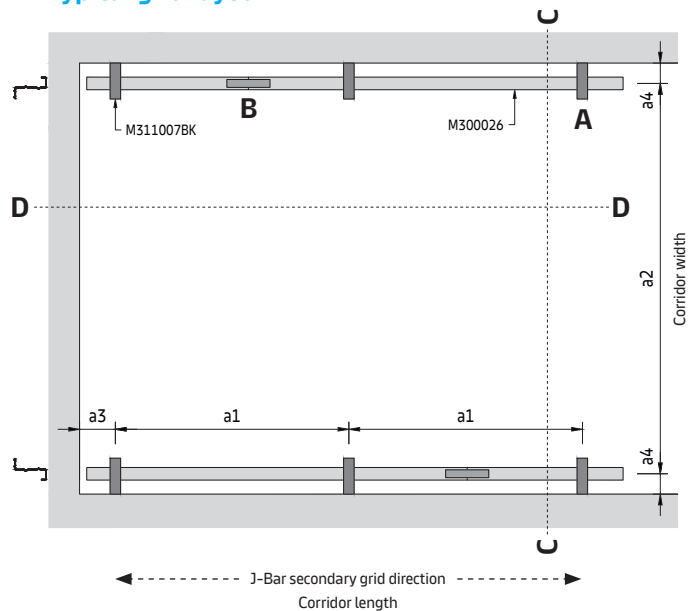

To determine suspension layout

The module length (M) of the requested ceiling is equal to the distance between the DP12 A-Bar centres (a2).

On the appropriate spacing table, read down the column headed (a2) to the required module length then read across to determine the suspension point spacing (a0) and direct hanger spacing (a1).

The shown values are maximum allowed distances and can be reduced but not exceeded.

MESH F-H 600 / MESH F-H 600 MT
D03.402

Detail A

J-Bar installation

1

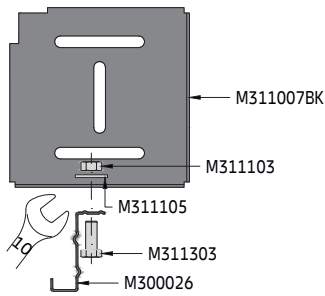

Fix the J-Bar with fasteners below the wall bracket.

2

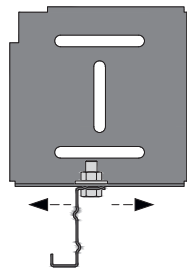

The J-Bar is now locked in position.

Detail B

Splice connection

1

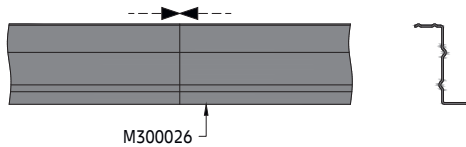

The ends of the J-Bars should be brought together without a gap.

2

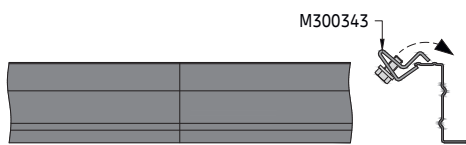

The connectors for the J-Bars must be inserted from above.

3

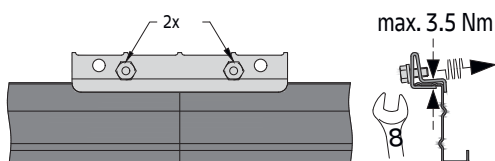

Use the bolts to secure the connector. Stagger the joints.

MESH F-H 600 / MESH F-H 600 MT

D03.402

Detail E

Panel insertion (example with MESH F-H 600)

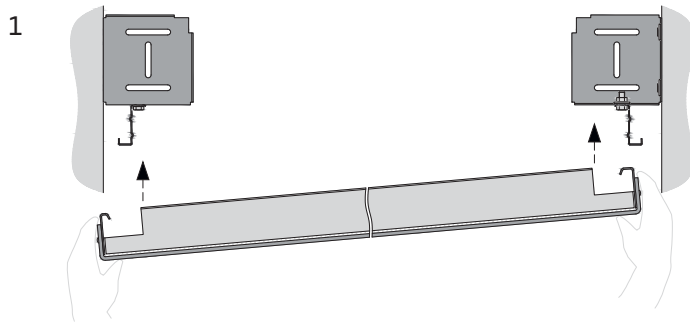

The panels are designed asymmetrically so that they can be hung in effortlessly.

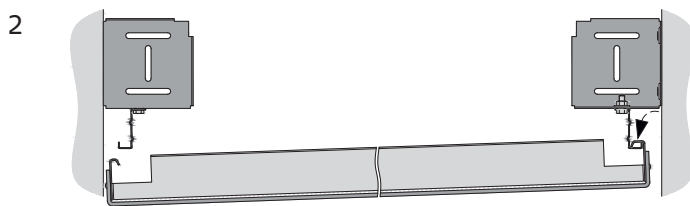

Hook the side with the wider hook edge detail into the J-Bar first.

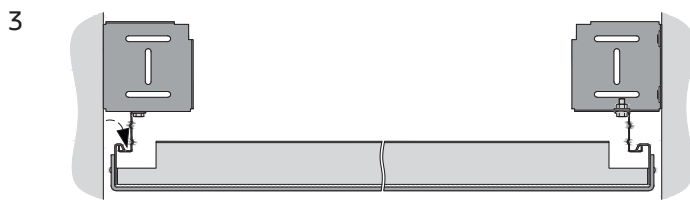

Followed by the side with the narrower hook edge detail.

Panel extraction (example with MESH F-H 600)

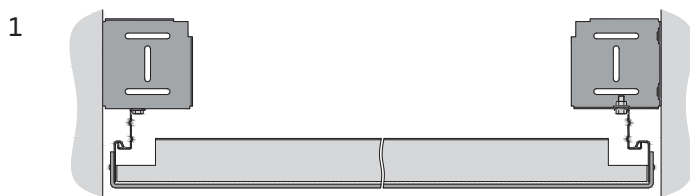

Each panel can be removed individually.

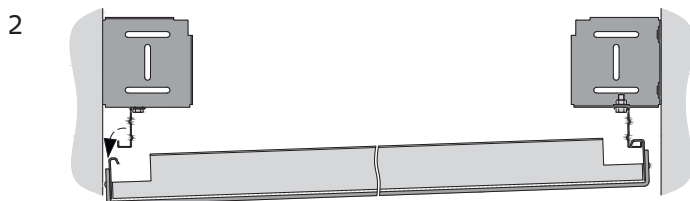

Unhook the side with the narrower hook edge detail first.

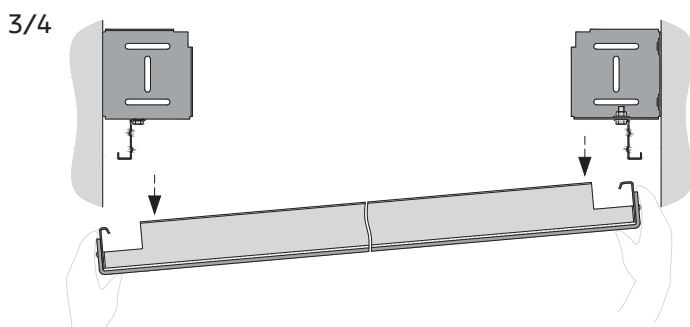

Followed by the side with the wider hook edge detail.

Remove it downwards and store the panel in a safe place so that it cannot be damaged.

MESH F-H 600 / MESH F-H 600 MT
D03.402

Detail F

Optional security bracket (example with MESH F-H 600)

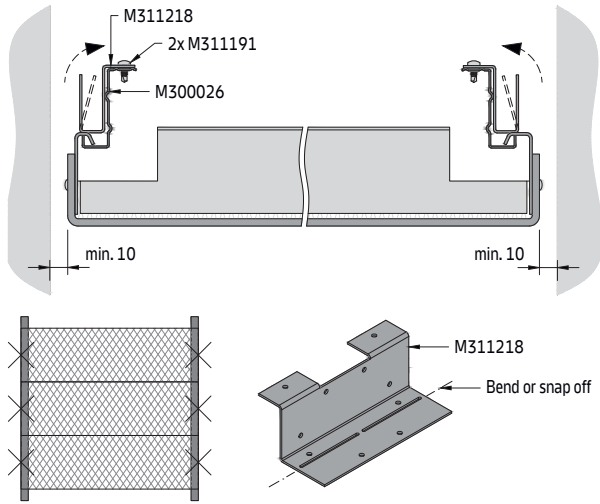

The security bracket serves to secure the panels and prevents them from being removed.

The security bracket can be fixed to the J-Bar with two self-drilling screws. The easiest way is from above, but a certain height is required for this. The bottom tab of the security bracket can either be bent up by hand or snapped off entirely.

Either individual panels or the entire ceiling can be secured. The panels are inserted and secured immediately. The last panel cannot be locked.

Detail G

Optional perimeter trim for cut panels (example with MESH F-H 600)

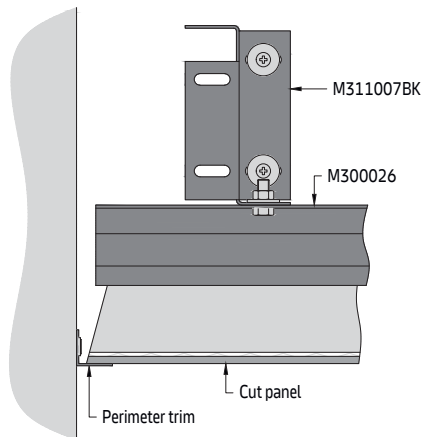
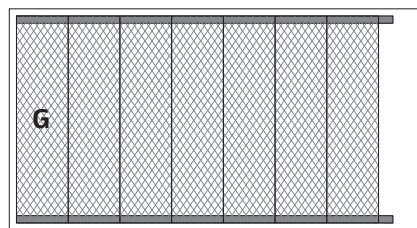

The last panel at the end of the corridor can be made to measure. A cost-effective alternative is to use a perimeter trim. This allows panels to be cut to size on site. See separate document for perimeter trim options.

Detail H

Optional perimeter trim for shadow gap (example with MESH F-H 600)

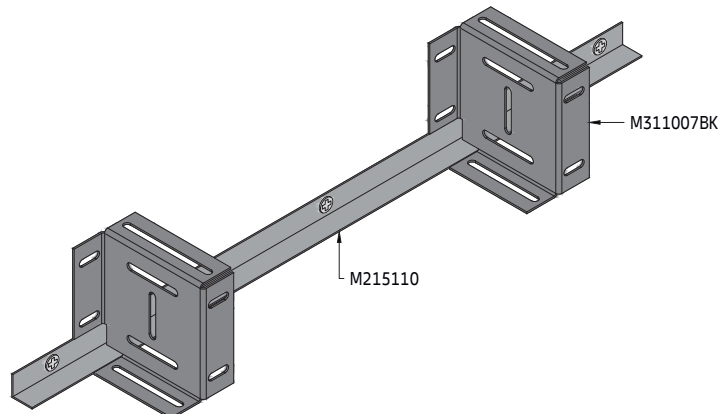
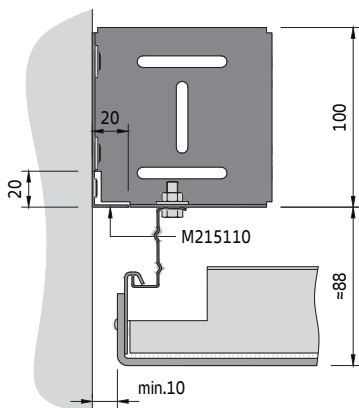

The shadow gap remains open in the standard version. Optionally, this can be covered with a perimeter trim. The perimeter trim is attached at the correct height so that the wall brackets can be placed on it and then attached to the wall.

MESH F-H 600 / MESH F-H 600 MT
D03.402

Detail I

Suspension option by double threaded rod (e.g. with MESH F-H 600)

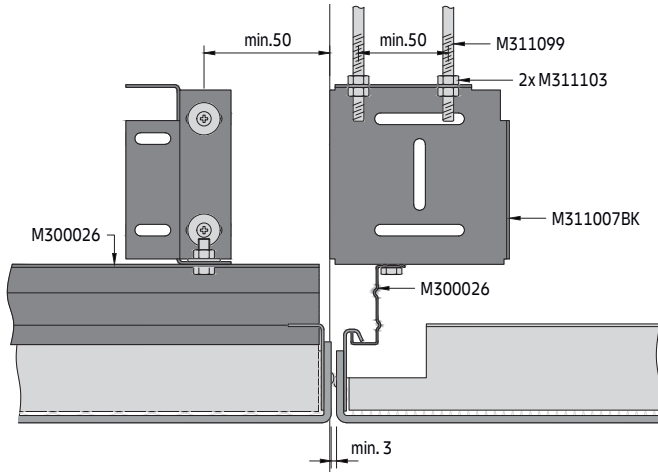

Suspension option by threaded rod with angle bracing

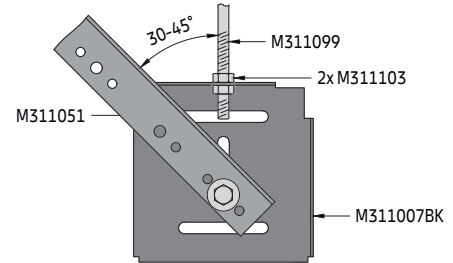

In these situations, the wall bracket can be suspended either with two threaded rods or one threaded rod and fixed by an angle bracing.

T-junction

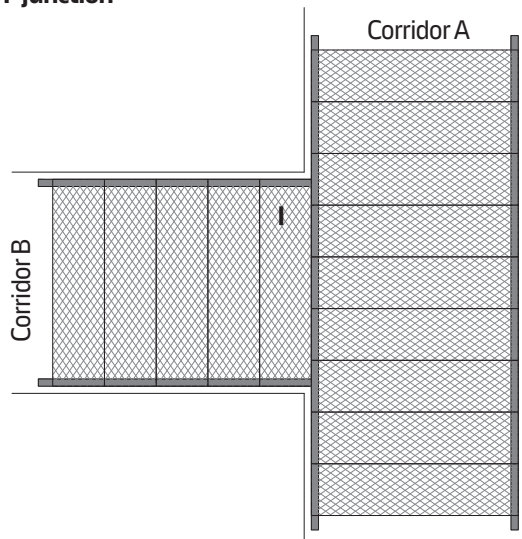

Corridor A runs through, corridor B connects to it and forms a T-junction.

Corner

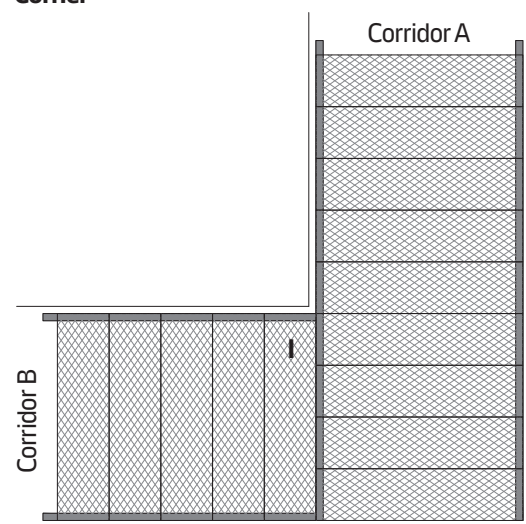

Corridor A runs to the end, corridor B connects to it and forms a transition.



MESH Sonic Element MT
MAKRO Cash & Carry Office, Warsaw, Poland © Szymon Polański



Floating Ceilings – Canopies

MESH SONIC Element MT

Threaded rod / hanging wire
Single canopy solution for indoor applications

General information

- Threaded rod or hanging wire for single suspension in open spaces
- Typical canopy weight 6.5 - 13.0 kg/m² (indicative value for canopies, without additional load)
- Visible edges
- Canopies are easily installed and fully demountable

Isometric view

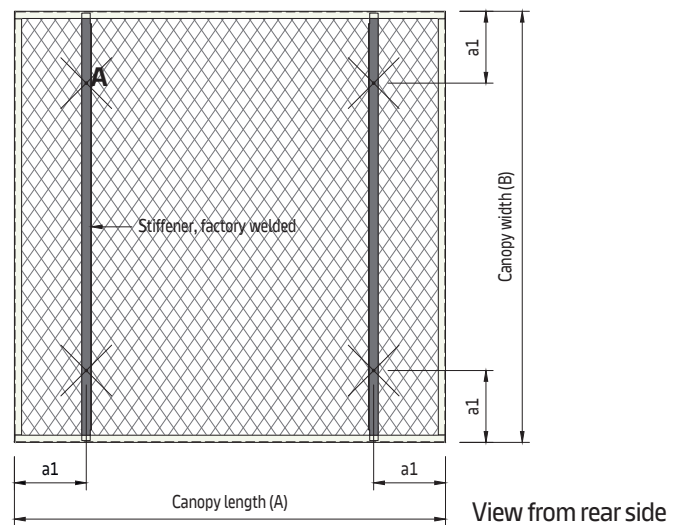
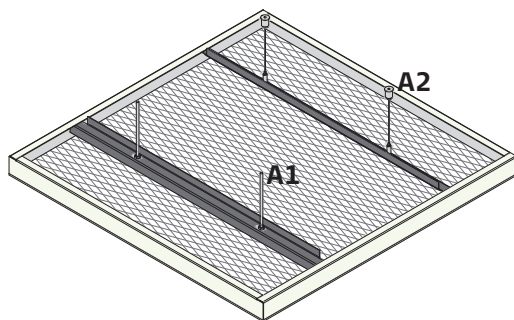

Important information

The hanging wires are supplied in a length of 4000 mm. If the room height is lower than this, the suspension points can be attached to the back of the canopy while it is on the ground. Please make sure that the visible side is protected during the assembly and cannot be scratched. In general, be careful when handling and transporting these large and heavy items. The canopy was primarily designed for horizontal installation. Slight angles are possible, but the limit must be checked beforehand. This installation depends on the dimensions and configuration of the canopy. A lateral distance of at least 200 mm is recommended for installation.

Vario Design & bespoke layout options

Vario Design

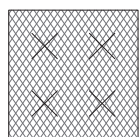

Bespoke (on request)

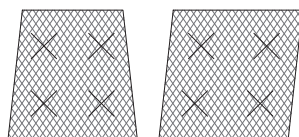

Parameters

- a1 200 mm
- A Canopy length = min. 600 / max. 1200 mm
- B Canopy width = min. 600 / max. 1202 mm *
- X Mesh thickness

* The dimensions depend on the chosen system and mesh pattern

Detail A1

Threaded rod installation

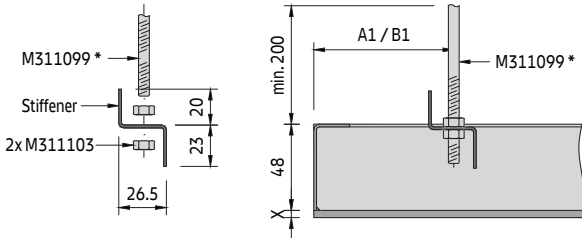

4x threaded rod M6 per canopy

Detail A3

Optional top fixing and extension detail

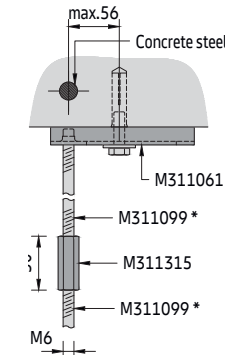

Top fixings by others

* Various lengths available

Detail A2

CS5550 Wire hanging installation

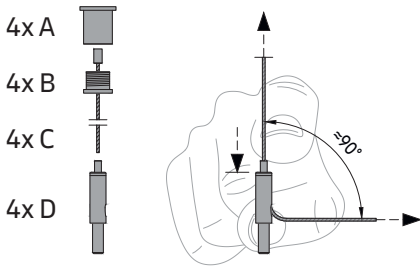

1 Place an M6 threaded bolt on the ceiling soffit (not offered by Knauf Ceiling Solutions).

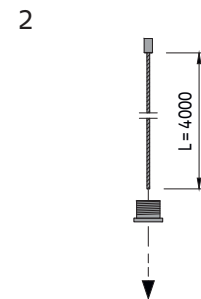

2 Take the hanging wire (C) and loop it through the top of the gripper anchor cap (B).

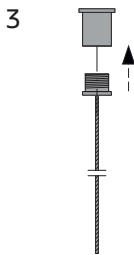

3 Screw the gripper anchor cap (B) onto the structure gripper anchor (A).

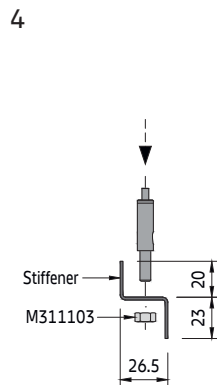

4 Screw the height adjuster (D) into the stiffener on the back of the canopy.

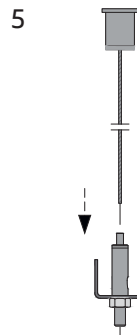

5 Guide the hanging wire (C) into the height adjuster (D). Pull the wire through the height adjuster, in an angle of $\approx 90^\circ$. Do not pull the wire upwards, otherwise it may be damaged.

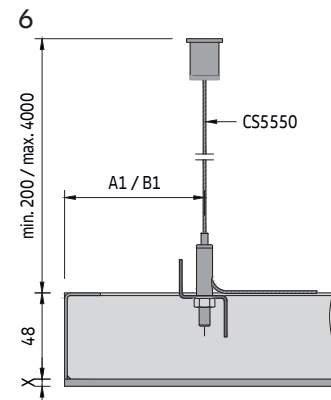

6 Then either roll up the wire and deposit it on the canopy or cut it away. After cutting it away, it can no longer be adjusted in height. Repeat this for all four suspension points.

MESH SONIC Element MT

E03.001

Grid components

Optional components

- M311103 Hexagonal nut M6
- M311303 Hexagonal bolt M6 x 16 mm

Optional components

- M311101 Threaded rod M6 x 1000 mm
- M311103 Hexagonal nut M6
- M311315 Hexagonal extension nut M6 x 30 mm (optional)
- M311061 Suspension element (optional)

Suspension option F2

- CS5550 Wire hanging M6
- M311103 Hexagonal nut M6

Detail B

Grouping option (by M6 bolt)



Grouping options

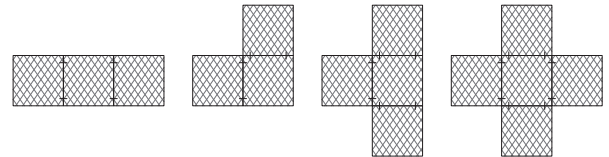

Optionally, the canopies can be supplied with additional holes. The sides that need to be provided with holes must be defined.



MESH Sky ELEMENT HOOK MT

(MESH D-H 700 MT)

U-Profile cross-connected grid

Concealed grid solution for indoor applications

General information

- Threaded rod or hanging wire for single suspension in open spaces
- Typical canopy weight 6.5 - 13.0 kg/m² (indicative value for canopies, without additional load)
- Visible edges
- Canopies are easily installed and fully demountable

Isometric view

Select the suspension option F1 - F3.

Important information

This system was developed for a single row of panels. In order for the components to be used, a panel length and width in steps of 25 mm must be maintained. For smaller module sizes, the U-Profile primary grid and the lateral U-Profiles can be assembled on the ground and then hung on the suspension points as a frame. Otherwise, the U-Profile primary grid is installed first and then the lateral U-Profiles attached to it.

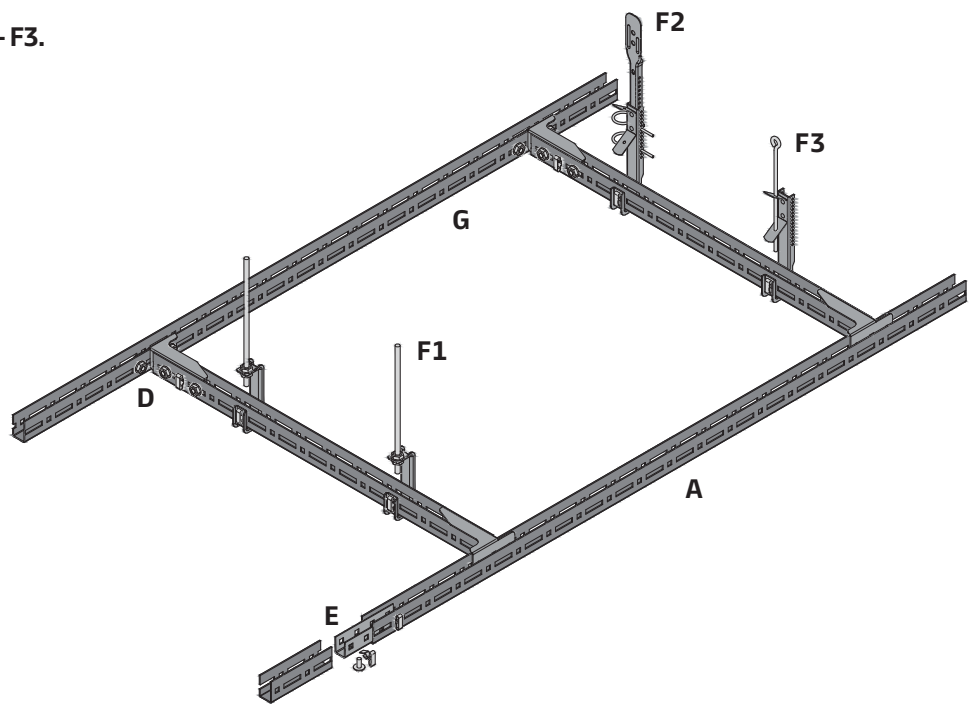

Vario Design layout options

Single

Double

Multiple

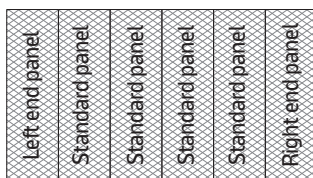
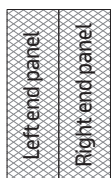

Detail A

U-Profile modulation

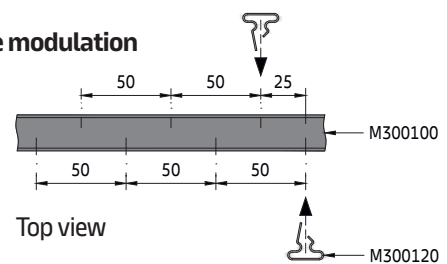

The U-Profile primary grid is a modular system based on a spacing of 50 mm. The holes on the lateral sides are offset from each other by 25 mm. This means that distances of 25 mm can be achieved.

Section B

Example with suspension option F1

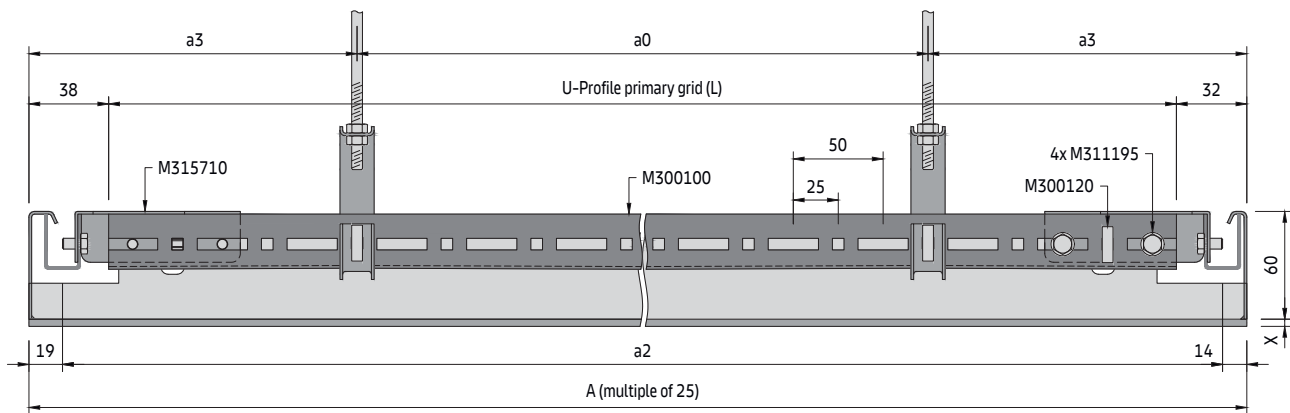

Section C

Example with suspension option F1

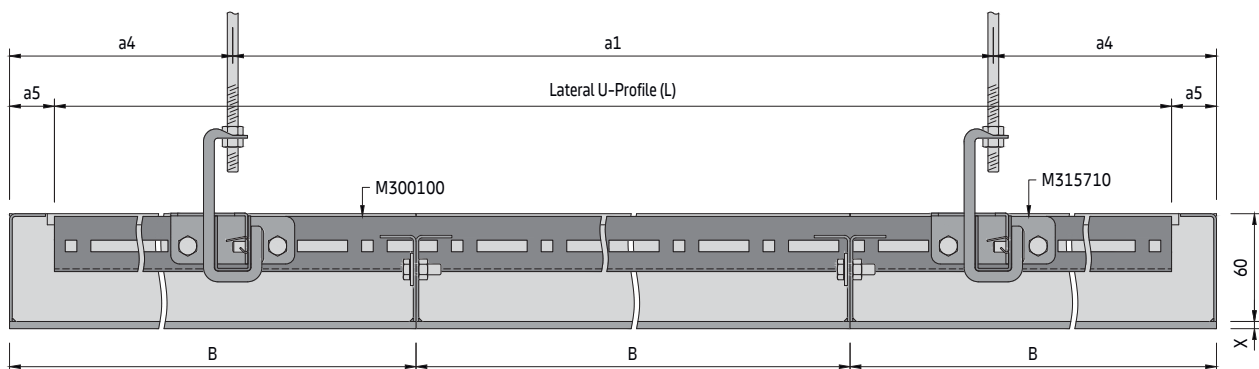

Grid components

Standard components

- M300100 U-Profile
- M300119 Splice connector for U-Profile
- M315710 Cross-connector for U-Profile
- M300120 Plug-in clip for U-Profile
- M311195 Thread cutting screw M6 x 10 mm

Suspension option F1

- M300366 Hanger for U-Profile
- M311103 Hexagonal bolt M6
- M300120 Plug-in clip for U-Profile
- M311315 Hexagonal extension nut M6 x 30 mm (optional)
- M311061 Suspension element (optional)

Suspension option F2

- M300166 Combi-Nonius hanger for U-Profile
- - Nonius top part (various lengths)
- M300036 Nonius locking pin
- M300120 Plug-in clip for U-Profile

Suspension option F3

- M300166 Combi-Nonius hanger for U-Profile
- - Eye wire (various lengths)
- M300120 Plug-in clip for U-Profile

Optional components

- M311103 Hexagonal nut M6
- M311105 Washer
- M311303 Hexagonal bolt M6 x 16 mm

MESH Sky ELEMENT HOOK MT
E03.002

U-Profile grid

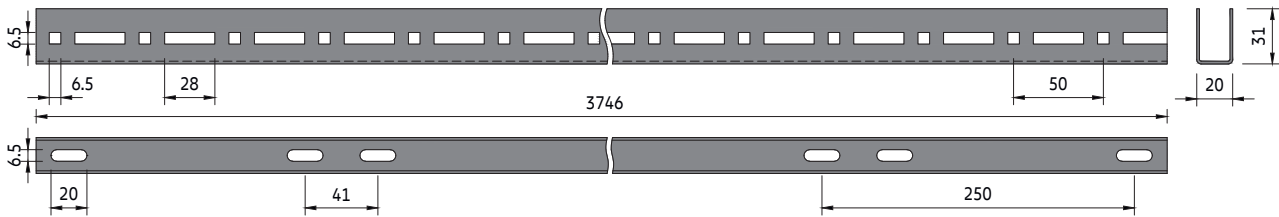

Spacing

a2 [mm]	System without additional load		System with additional load +4 kg/m ²	
	a0 [mm]	a1 [mm]	a0 [mm]	a1 [mm]
800	500	1200	500	1100
900	400	1200	400	1100
1000	700	1200	700	1100
1100	800	1200	800	1100
1200	900	1200	900	1100
1300	1000	1200	1000	1100
1400	1100	1200	1100	1100
1500	1200	1200	1200	1100
1600	1300	950	1300	900
1700	1400	950	1400	900
1800	1500	950	1500	900
1900	1600	950	1600	900
2000	1700	950	1700	900
2100	1800	950	1800	900
2200	1900	950	1900	900
2300	1000	950	1000	900
2400	1050	950	1050	900
2500	1100	950	1100	900
2600	1150	950	1150	900
2700	1200	950	1200	900
2750	1225	950	1225	900

To determine suspension layout

The panel length (A) of the requested ceiling is equal to the distance between the lateral U-Profile centres (a2) - 33 mm.

On the appropriate spacing table, read down the column headed (a2) to the required module length then read across to determine the suspension point spacing (a0) U-Profile primary grid spacing (a1).

The shown values are maximum allowed distances and can be reduced but not exceeded.

Parameters

- a0 Distance between U-Profile suspension points = max. 1900 mm
- a1 Max. distance between U-Profiles
- a2 Distance between lateral U-Profiles = panel length (A) - 33 mm
- a3 Distance from panel edge to suspension point = min. 125 / max. 250 mm
- a4 Distance from end panel edge to U-Profile = min. 150 / max. 350 mm
- a5 Distance from end panel edge to lateral U-Profile end = max. 25 mm
- A Panel length = min. 600 / max. 2485 mm (in steps of 25 mm)*
- B Panel width = min. 250 / max. 700 mm
- X Mesh thickness

*The dimensions depend on the chosen system and mesh pattern

Typical grid layout

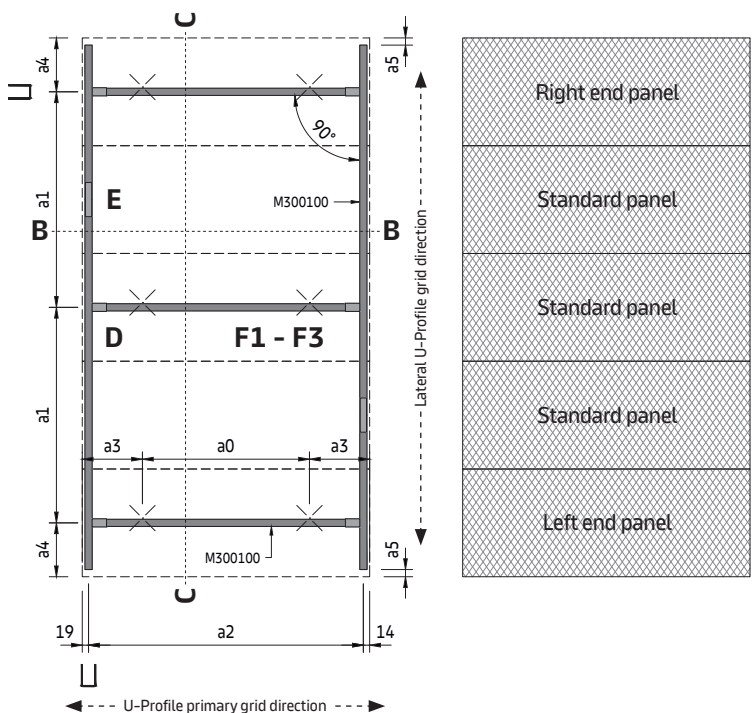

MESH Sky ELEMENT HOOK MT
E03.002

Detail D

Cross-connector installation

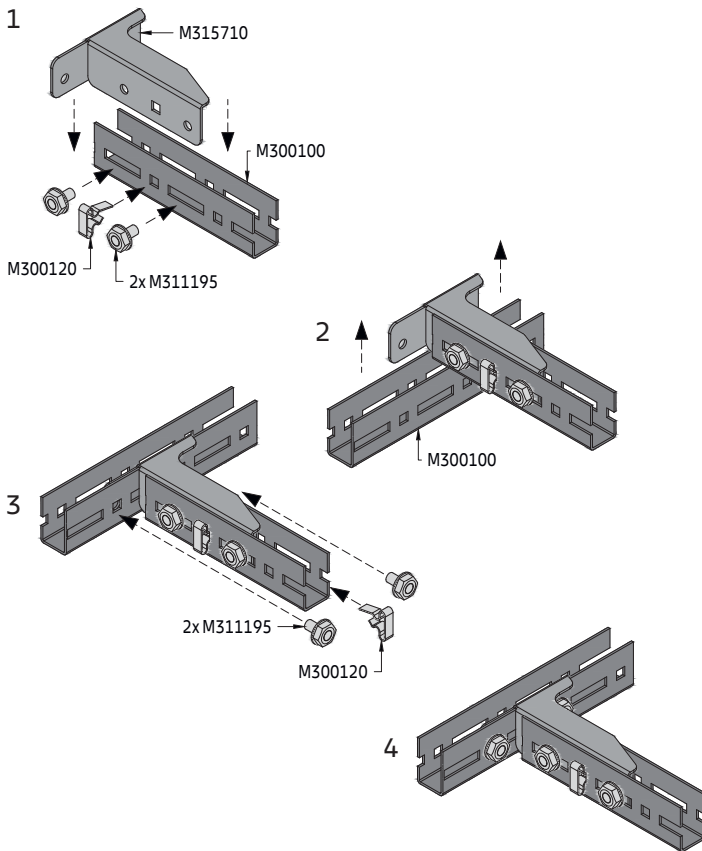

The cross-connector for U-Profile is fixed at both ends of the U-Profile primary grid. In order for this to work, a module dimension in 25 mm increments must be maintained. The plug-in clip can be used for positioning. The fixation itself is done with thread cutting screws. Standard M6 bolts cannot be used.

Align the lateral U-profile in the longitudinal direction and insert it so that the cross-connector is hooked.

Again use a plug-in clip and two thread cutting screws to fix the lateral U-Profile to the cross-connector.

The two profiles are now connected. Only a 90° connection is possible.

Detail E

Splice connection

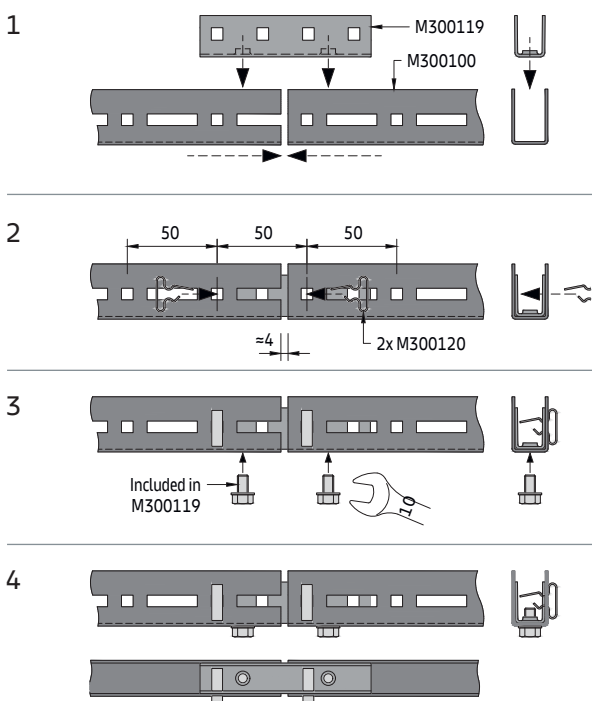

The splice connector for U-Profile comes with two bolts, which must first be removed. The splice connector is then placed between the two ends of the U-Profiles.

Fix the splice connector with two plug-in clips (large end upwards) at each end. This ensures the modular distance of 50 mm.

For a stable connection, the two supplied bolts are attached from below.

Since the U-Profile is a modular system, the ends must not touch. There is a distance of approx. 4 mm, depending on the length tolerance of the profile. Joints should be offset.

Detail F

Suspension options

Option F1

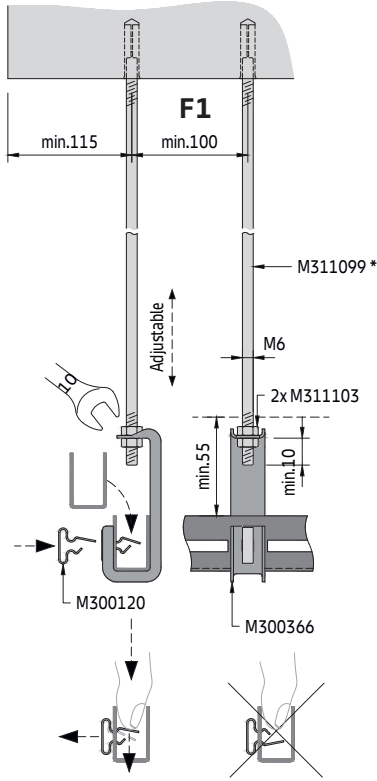

Option F2

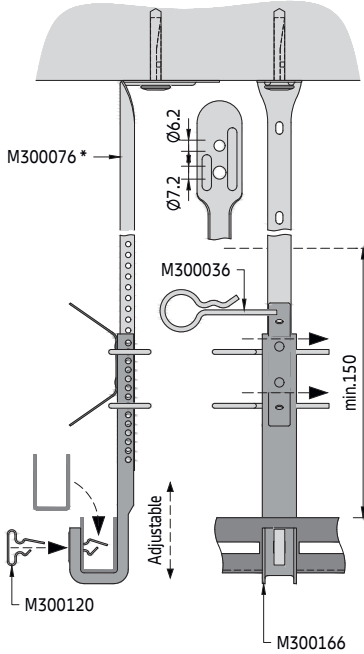

Please make sure that the elements have an overlap of at least 40 mm.

Option F3

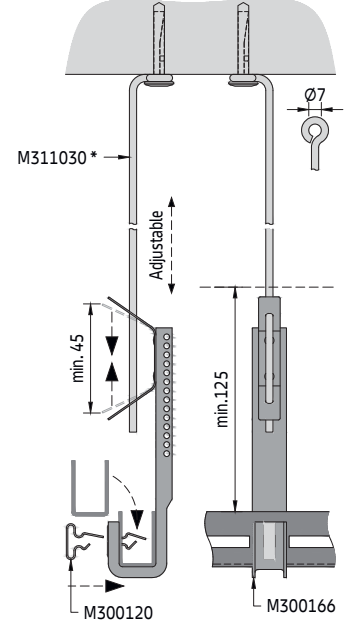

The clip should only be compressed as indicated to avoid possible damage.

Detail F4

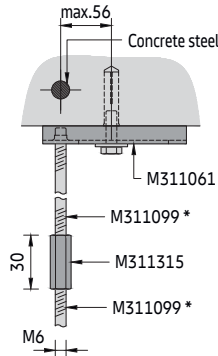

Optional top fixing and extension detail for suspension option F1

Suspension option F1 is recommended as it is the least visible from below.

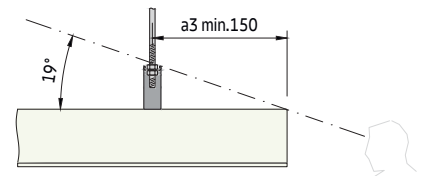

* Various lengths available

Detail G

Panel locking

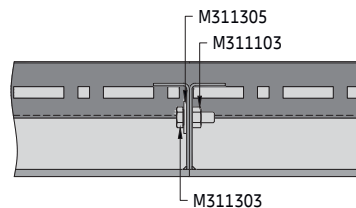
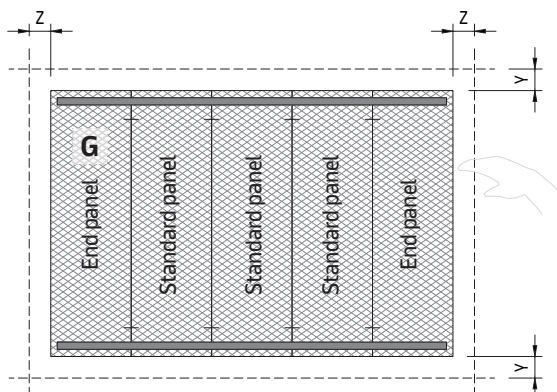

- Y Space from the short side = min. 100 mm
- Z Space from the long side = min. 200 mm

Since the panels are only hooked-on, their position can shift, e.g. due to vibrations or maintenance work. To prevent this, the end panels are held in place with M6 bolts. Two bolts are required per panel.

The panels are fixed while installing the panels. This requires a min. space from either the long or short side of the canopy.

Detail H

Panel insertion

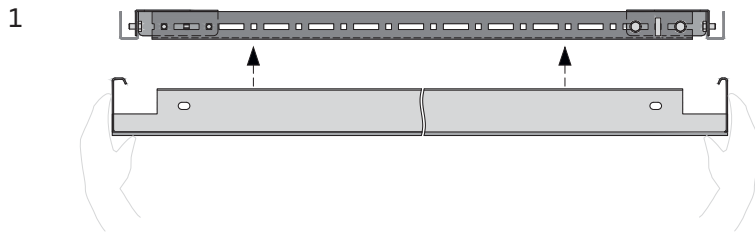

Take the panel...

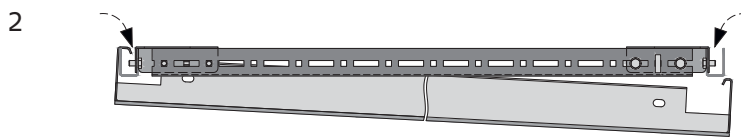

and hook it on both lateral U-Profiles. Start first with the short side with the wider hook edge, followed by the short side with the small hook.

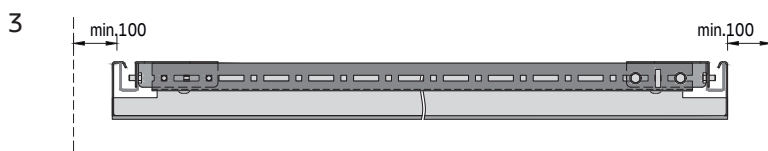

A lateral space of min. 100 mm is recommended in order to be able to hook-on the panels.

Panel extraction



If you want to extract an end panel, the bolts must first be removed (see detail G).

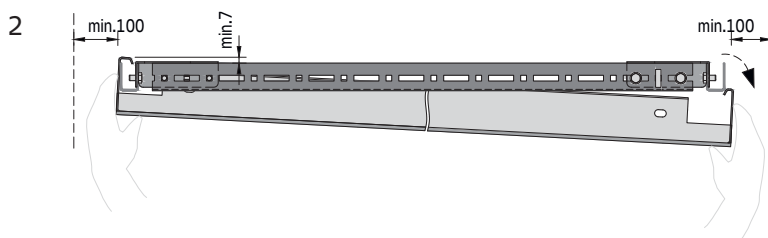

Lift the panel by at min. 7 mm and un-hook it, starting with the short side with the small hook edge, followed by the short side with the wide hook.

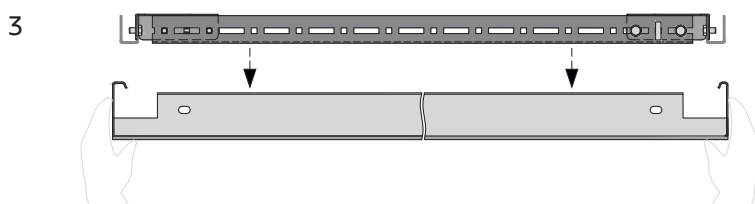

Remove it downwards and store the panel in a safe place so that it cannot be damaged.



MESH Board

Air Hotel, Kaunas, Lithuania © Szymon Polański



Perimeter trims & Transitions

MESH Perimeter Solutions

Range of perimeter trims for mesh ceilings
For indoor applications

General information

- Solutions for small, medium and large rooms, as well as corridors
- Perimeter trims made of aluminium and steel
- Perimeter trims for most common construction
- Shadowline trims for alternative construction (shadow gap)
- Available in standard RAL 9010, further colour options on request
- Curved trims and column rings

Aluminium perimeter trims

RA 1 perimeter trim

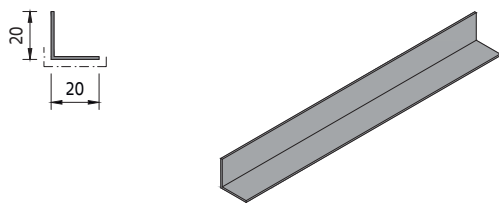

RA 2 perimeter trim

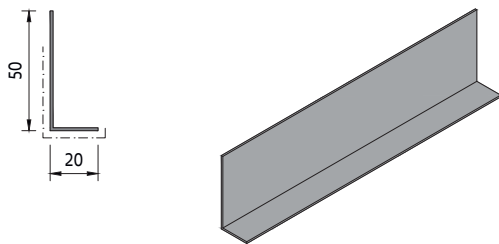

RA 3 shadowline perimeter trim

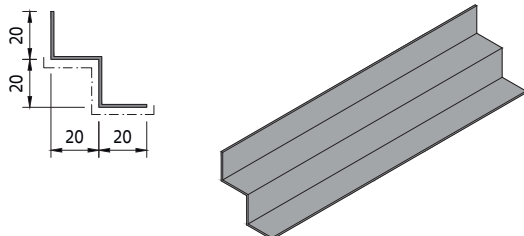

Generally, installation has to be carried out with approved fixings suitable for the type of wall being fixed to. Flat headed screws are recommended to prevent deformation of the trim. Wall fixings are not offered by Knauf Ceiling Solutions.

----- Coated surface

Galvanised steel perimeter trims

RA 1 S perimeter trim

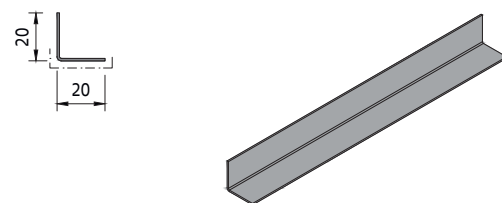

RA 3 S shadowline perimeter trim

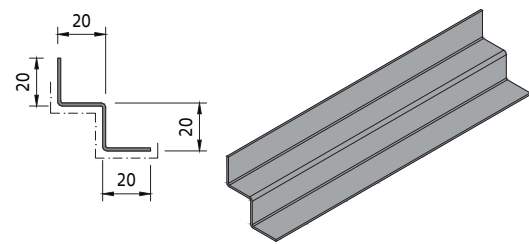

Perimeter L

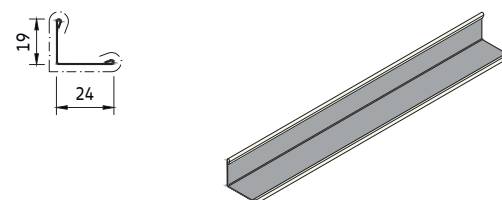

Shadowline perimeter

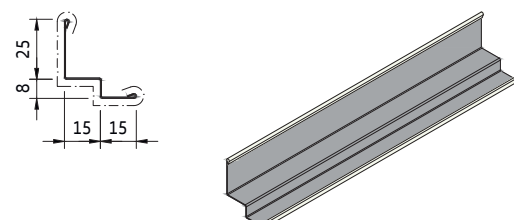

MESH Perimeter Solutions

T03.001

Perimeter trims		Length (L) [mm]	max. (X) [mm]	min. (Y) [mm]
M215110	RA 1	4000	600	12
M215111	RA 2	4000	600	12
M215112	RA 3	4000	600	14
M215213	RA 1 S	3000	600	12
M215214	RA 3 S	3000	600	14
Various	Perimeter L 19 x 24 mm	3000	600	16
Various	Shadowline perimeter trim 25 x 15 x 8 x 15 mm	3000 / 3050	600	10



Perimeter trim corner details

For 90° corners, perimeter trims are butt cut. Mitred cuts require increased precision and time.

Butt-cut inside corner

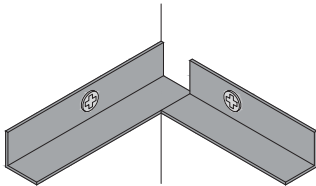

Mitre-cut inside corner

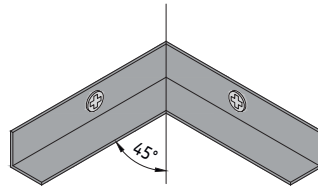

Mitre-cut outside corner

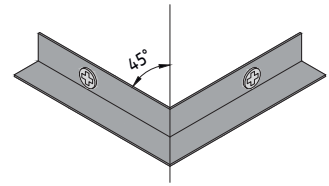

Shadowline perimeter trim corner details

Shadowline perimeter trims are mitred as standard.

Mitre-cut inside corner

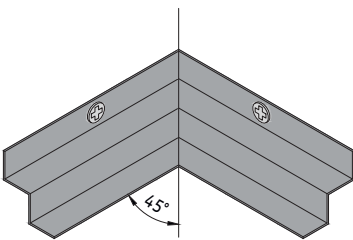

Mitre-cut outside corner

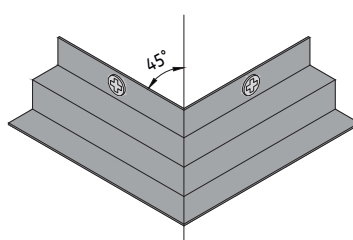

MESH Perimeter Solutions

T03.001

Curved perimeter trims

Standard perimeter trims can be supplied curved on request. With this, details for curved walls, skylights, column rings, etc. can be solved.

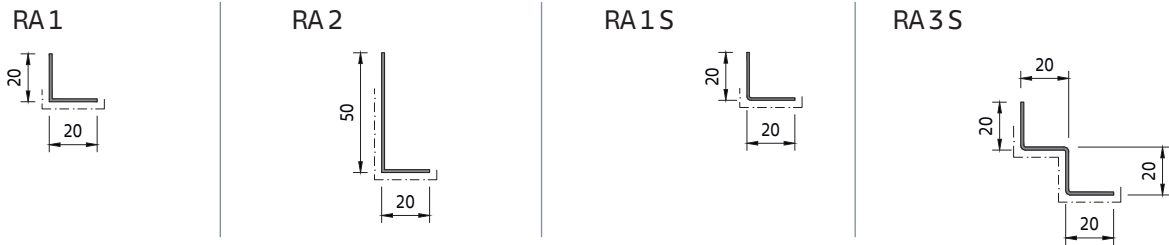

The ends of the perimeter trims are supplied straight and must be cut on site. In this way, they can be fitted and structural tolerances can be accommodated.

Curved outward

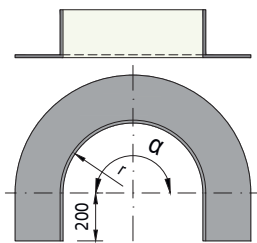

Curved inside

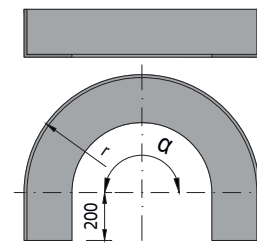

Curved perimeter trims	Curved outward Radius (r) min. [mm]	Curved inside Radius (r) min. [mm]	Angle (α) max. [mm]
RA 1 curved	90	750	180
RA 2 curved	300	750	180
RA 1 S curved	90	750	180
RA 3 S curved	120	800	180

Column rings

Column rings are delivered in two parts, which simplifies assembly.

Semi-circular column ring

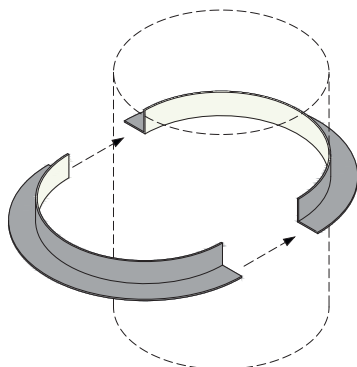

Semi-circular shadowline column ring

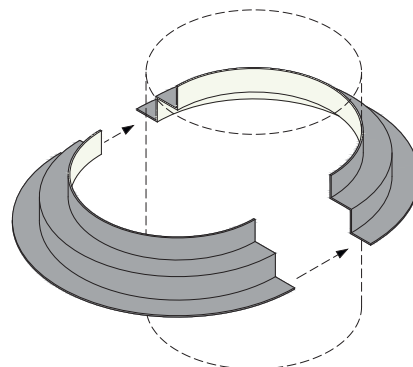

----- Coated surface



MESH Steel Bulkhead Solutions

Range of bulkheads for mesh ceilings
For indoor applications

General information

- Solutions for small, medium and large rooms, as well as corridors
- Bulkheads made of steel
- A range of standard bulkheads and Vario Design options
- Available in standard RAL 9010, further colour options on request
- For vertical closure and change in level
- Inside / outside corner options on request

Application area

Vertical closure

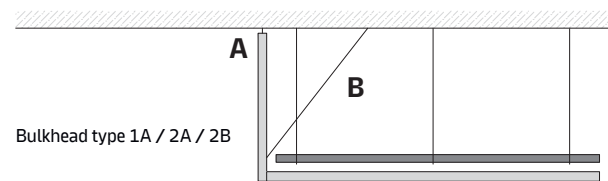

Change in level

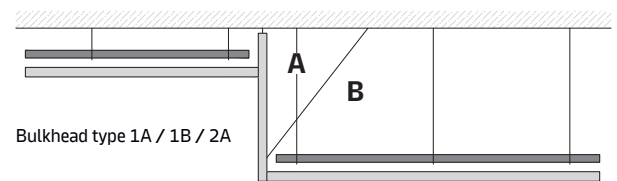

Bulkhead orientation

Reclined

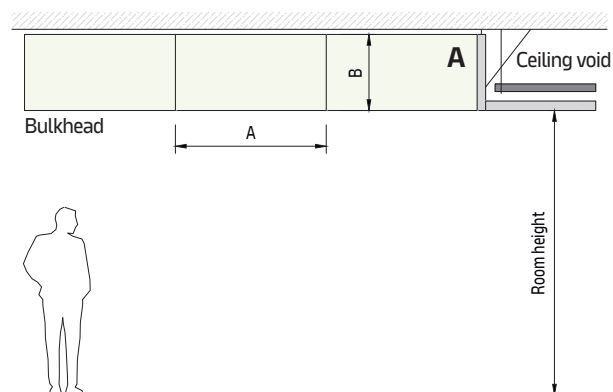

Upright

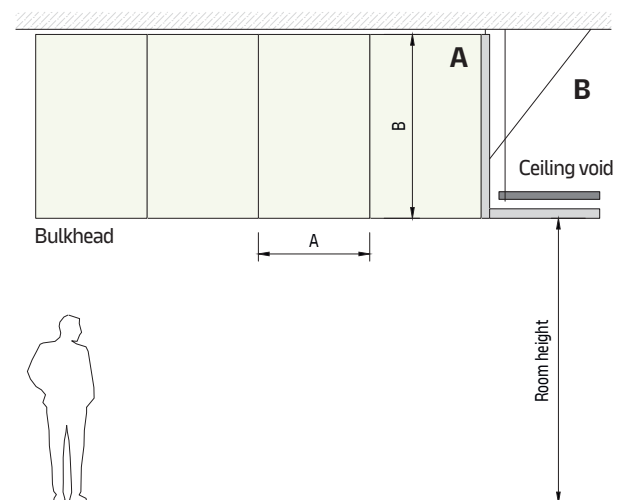

MESH Steel Bulkhead Solutions

T03.002

Detail A

Threaded rod

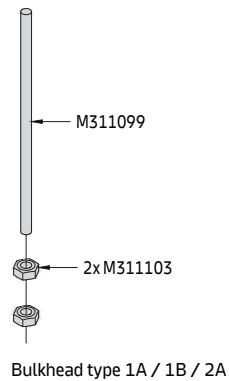

Attachment bracket

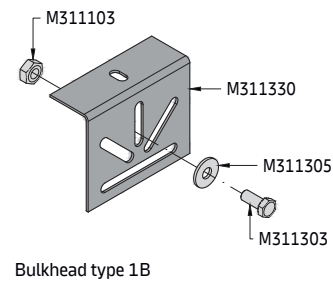

Depending on the bulkhead type and detail, two suspension options are available.

- a0 Distance between suspension points = max. 600 mm
- a1 Distance from bulkhead end to suspension point = max. 300 mm

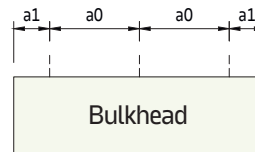

Detail B

Angle bracing

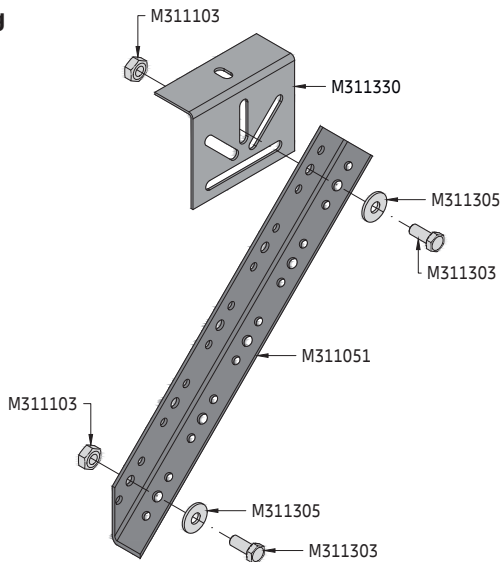

The bulkheads must be secured with an angle bracing in the lower half. A primary angle is suitable for this, which is attached to the bulkhead with M6 bolts.

The angle bracing is attached at an angle of max. 45°.

At the top, an attachment bracket gets fixed to the plenum. The primary angle can be easily connected with the long holes by using an M6 bolt.

Accessories		Length (L) [mm]
M215110	RA 1	4000
M215111	RA 2	4000
M215112	RA 3	4000
M311051	Primary angle 3000 x 27 x 22 mm	3000
M311081	Pressure spring (for F-perimeter trims)	-
M311099	Threaded rod M6 x 1000 mm	1000
M311103	Hexagonal nut M6	-
M311105	Washer	-
M311303	Hexagonal bolt M6 x 16 mm	-
M311330	Attachment bracket	-
M311191	Self-drilling screw 3.5 x 9.5 mm	-

Bulkhead type 1A

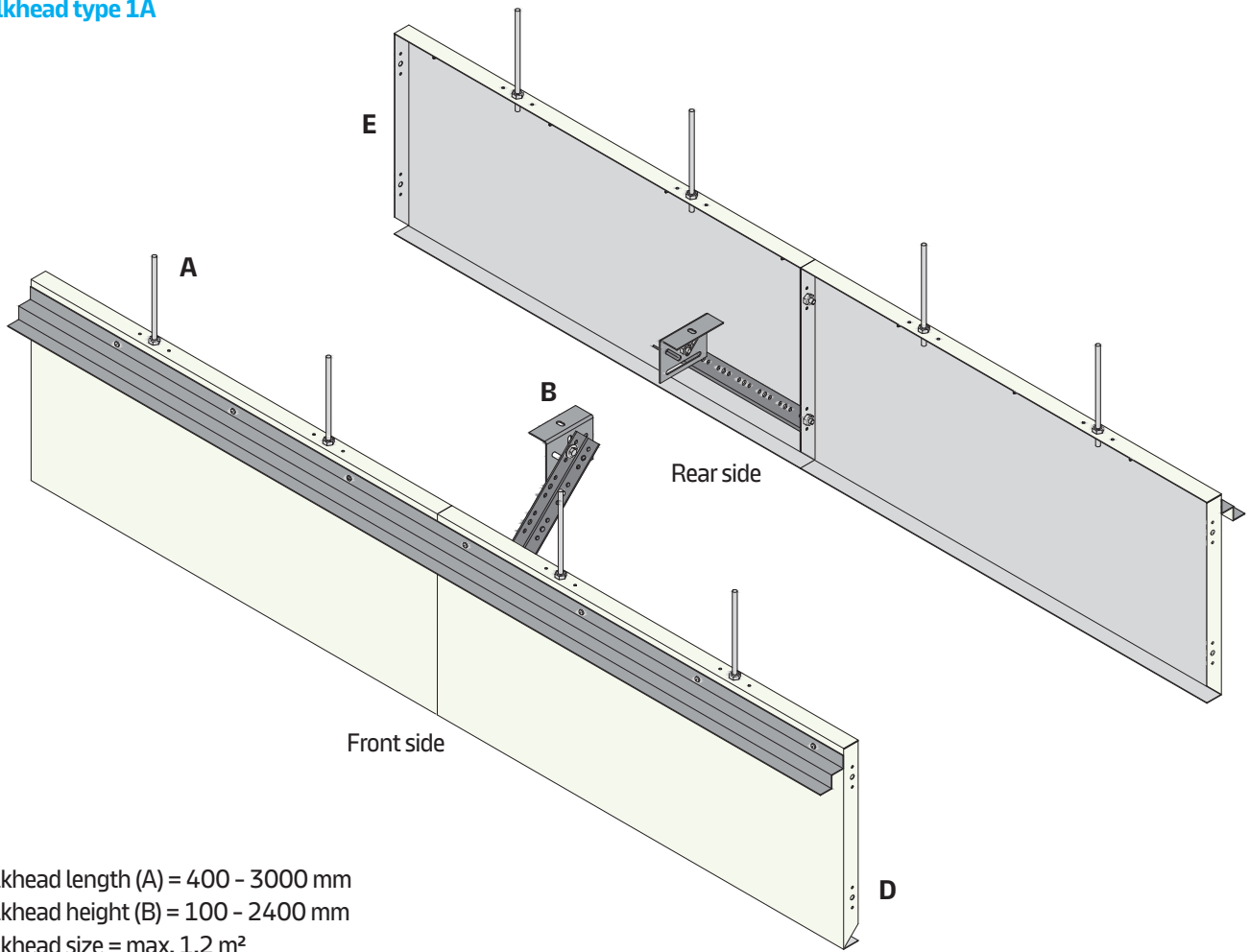

Bulkhead length (A) = 400 - 3000 mm
 Bulkhead height (B) = 100 - 2400 mm
 Bulkhead size = max. 1.2 m²

Option C1
 Vertical closure

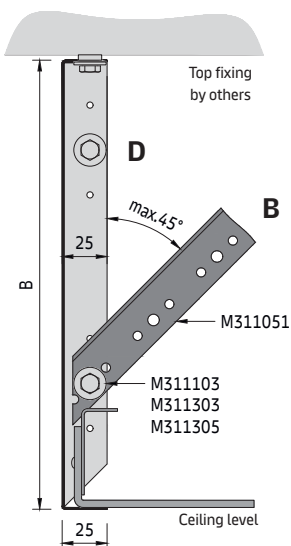

Option C2
 Change in level with RA 1

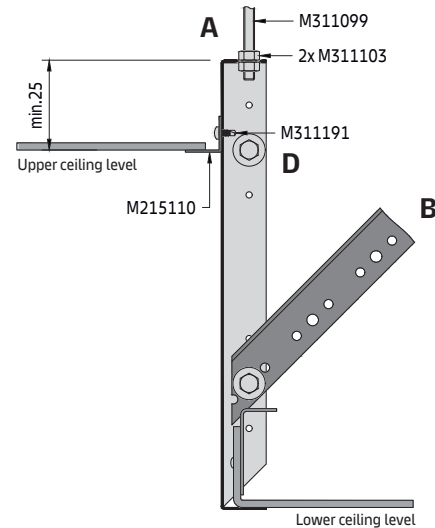

Option C3
 Change in level with RA 3

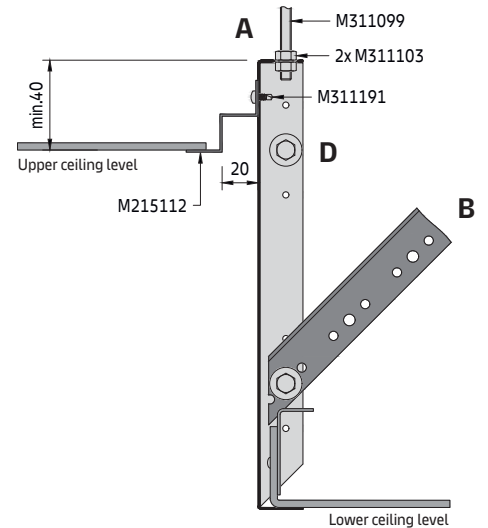

MESH Steel Bulkhead Solutions

T03.002

Detail D

Bulkhead connection

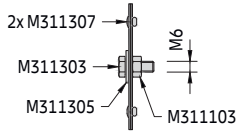

The bulkheads can either be connected by two pop-rivets or a M6 bolt.

Option E1

Cut bulkhead wall detail with RA 1

Perimeters fixed to the bulkhead in a distance of max. 600 mm.
Perimeter solutions on separate datasheet.

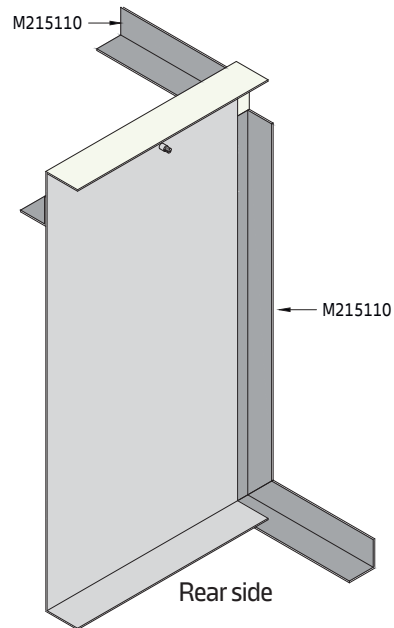
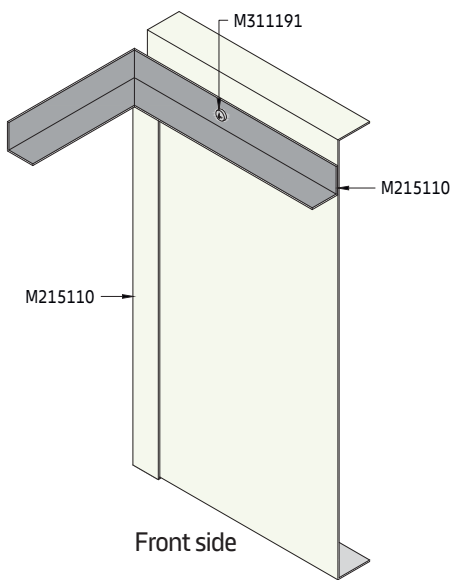

Option E2

Cut bulkhead wall detail with RA 3

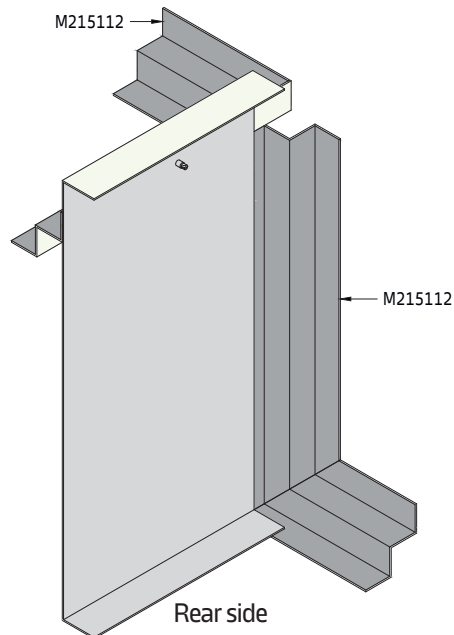
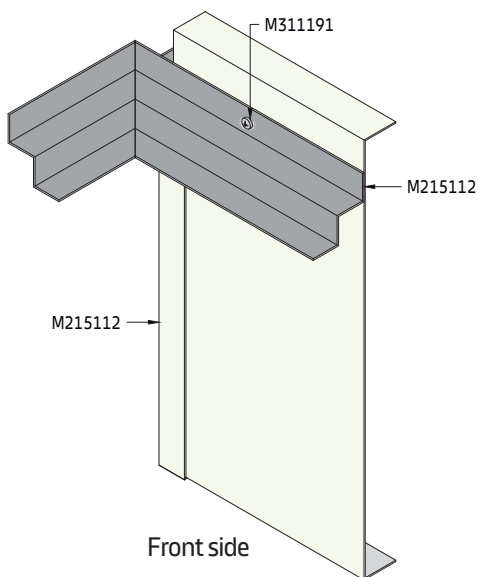

Bulkhead type 1B

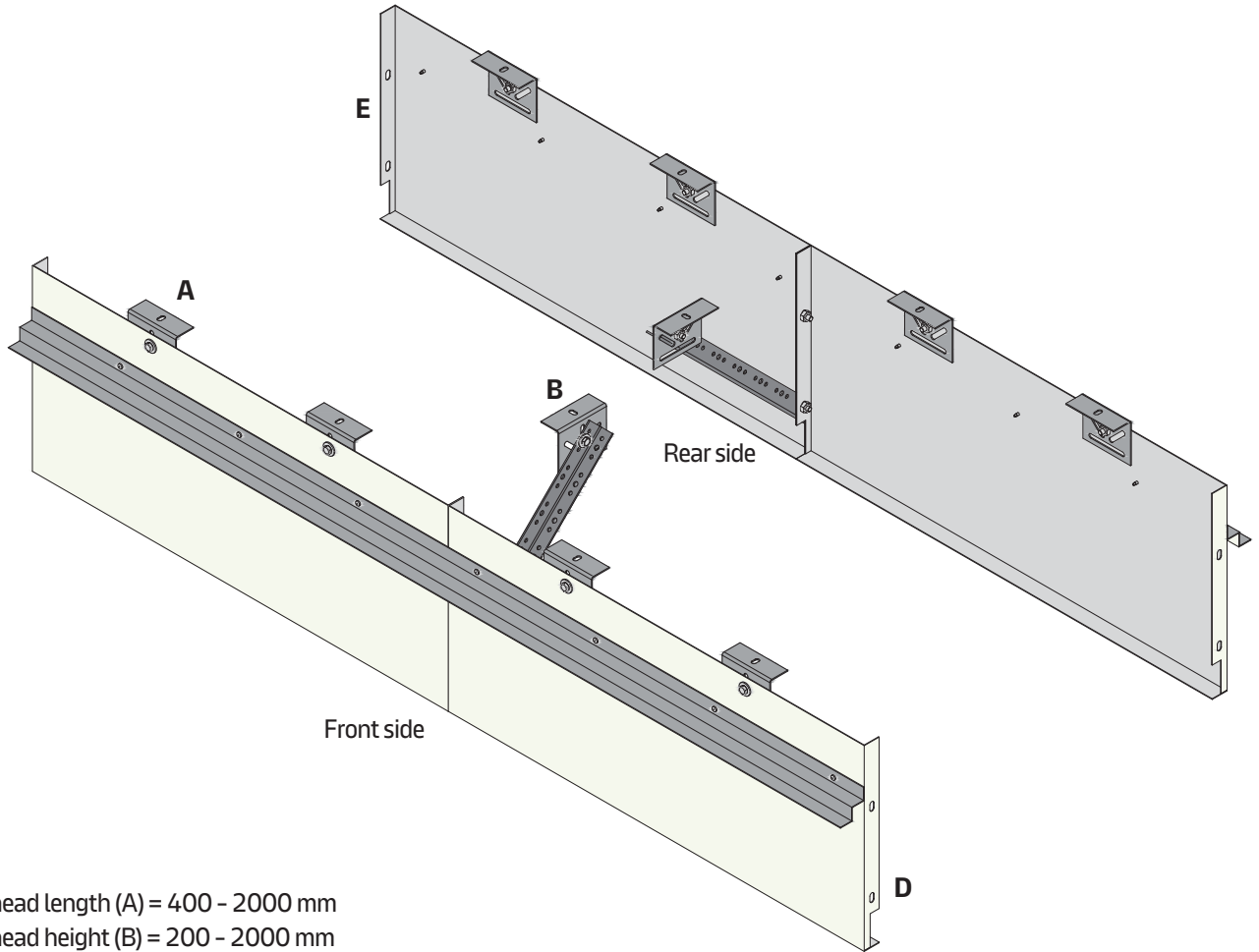

Bulkhead length (A) = 400 - 2000 mm
 Bulkhead height (B) = 200 - 2000 mm
 Bulkhead size = max. 1.2 m²

Option C1

Change in level with RA 1

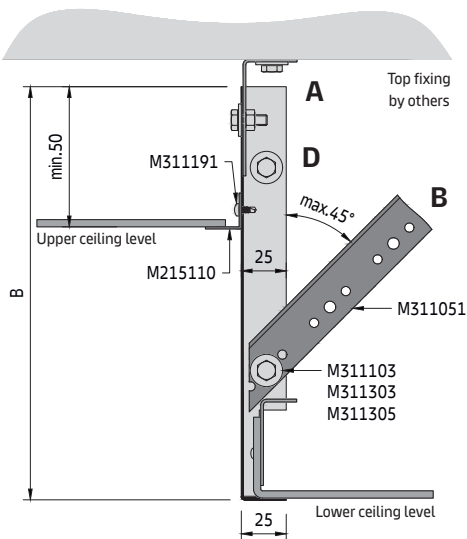

Option C2

Change in level with RA 3

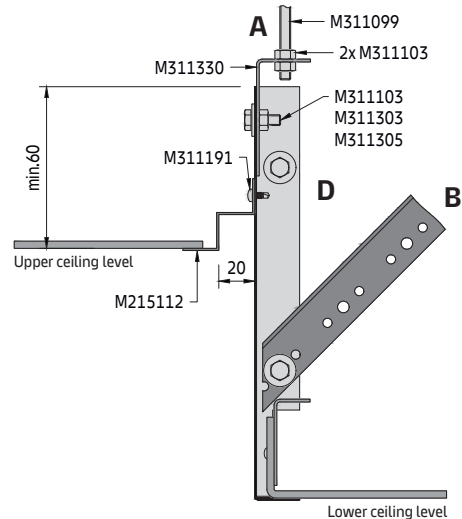

Detail D

Bulkhead connection

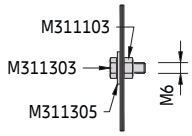

Option E1

Cut bulkhead wall detail with RA 1

Perimeters fixed to the bulkhead in a distance of max. 600 mm.
Perimeter solutions on separate datasheet.

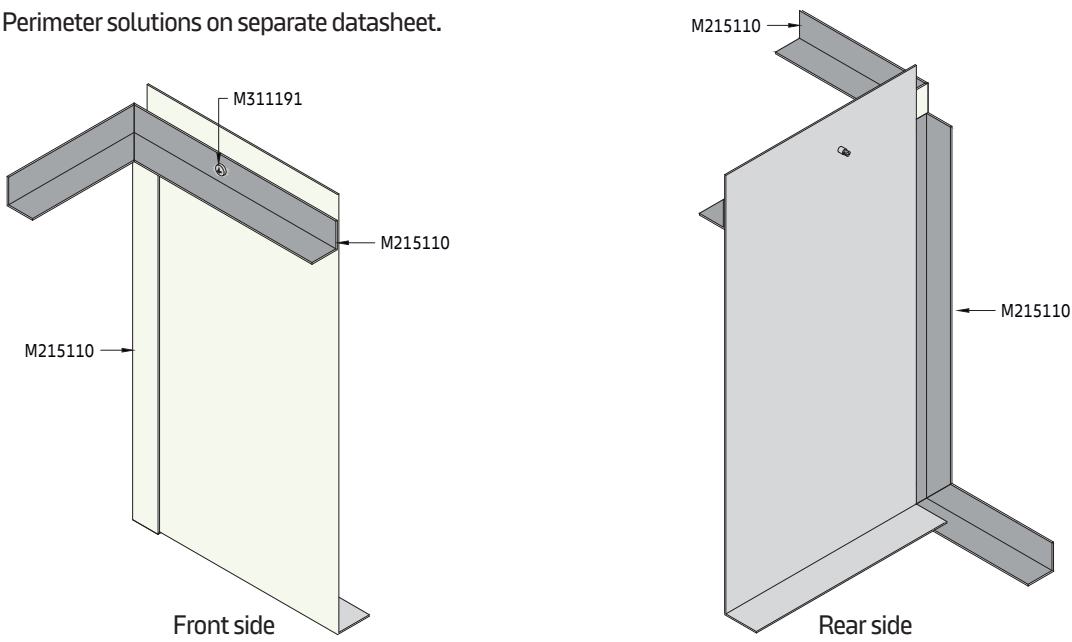

Option E2

Cut bulkhead wall detail with RA 3

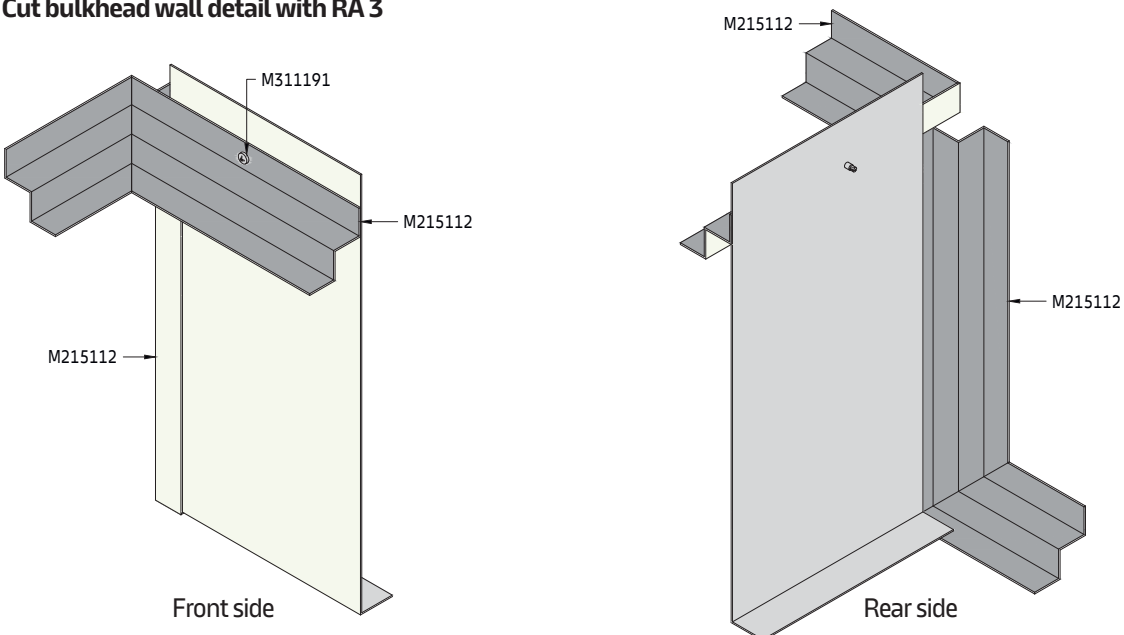

Bulkhead type 2A

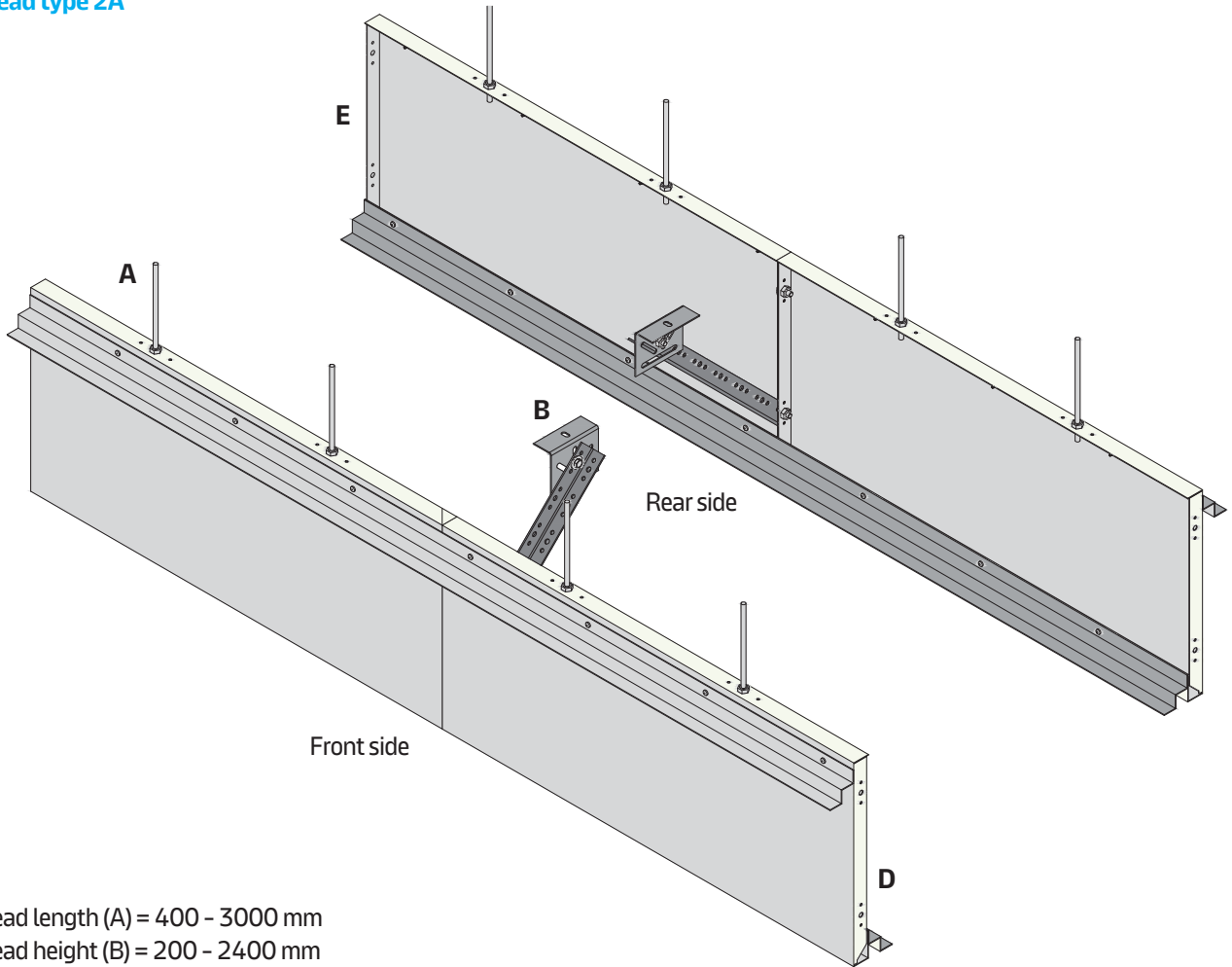

Bulkhead length (A) = 400 - 3000 mm
 Bulkhead height (B) = 200 - 2400 mm
 Bulkhead size = max. 1.2 m²

Option C1
 Vertical closure

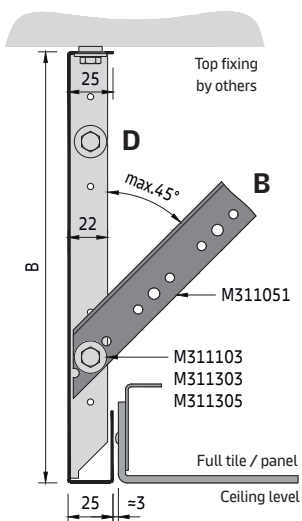

Option C2
 Change in level with RA 1

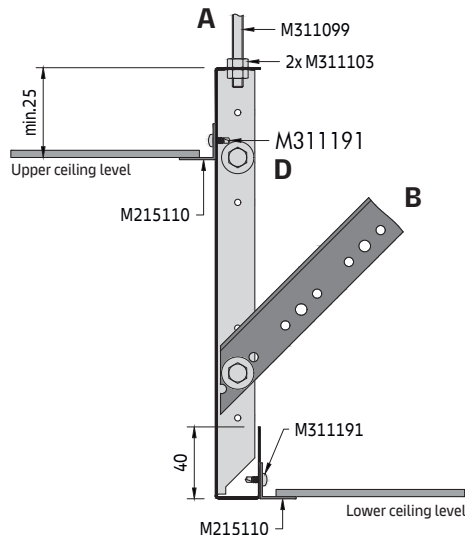

Option C3
 Change in level with RA 3

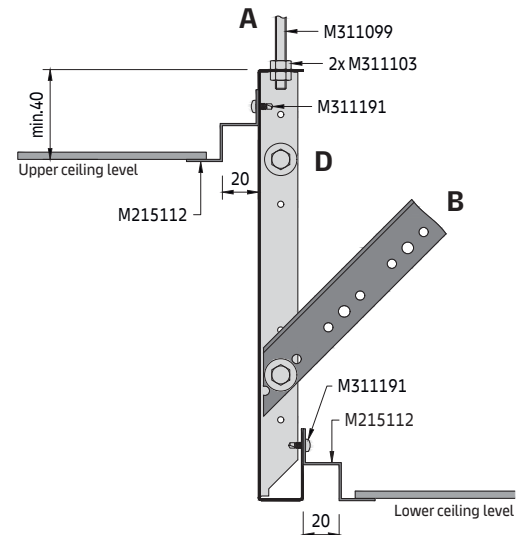

MESH Steel Bulkhead Solutions

T03.002

Detail D

Bulkhead connection

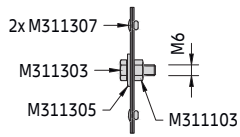

The bulkheads can either be connected by two pop-rivets or a M6 bolt.

Option E1

Cut bulkhead wall detail with RA 1

Perimeters fixed to the bulkhead in a distance of max. 600 mm.
Perimeter solutions on separate datasheet.

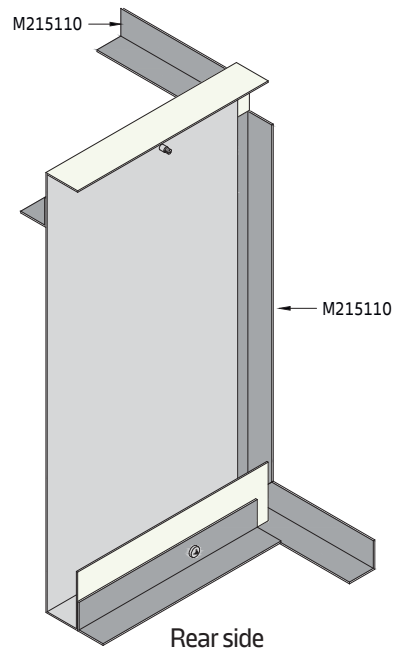
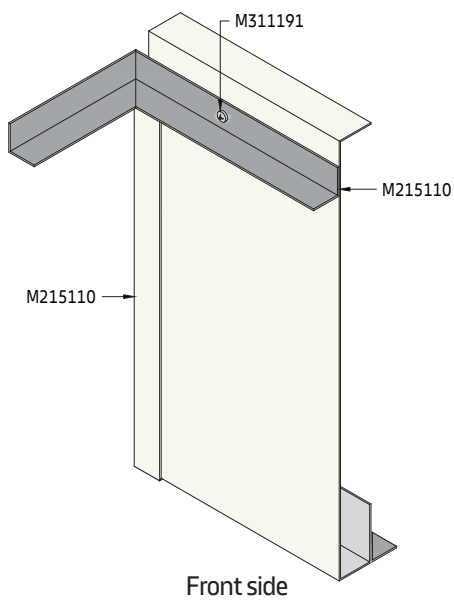

Option E2

Cut bulkhead wall detail with RA 3

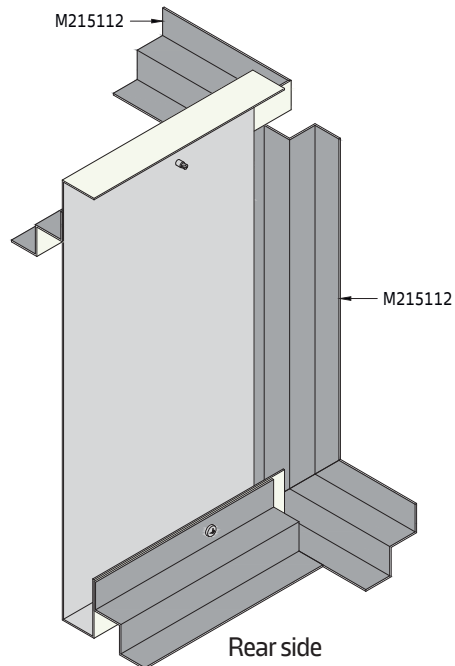
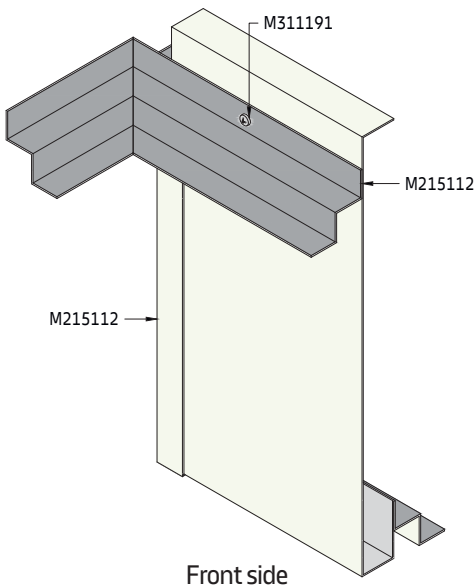

Bulkhead type 2B

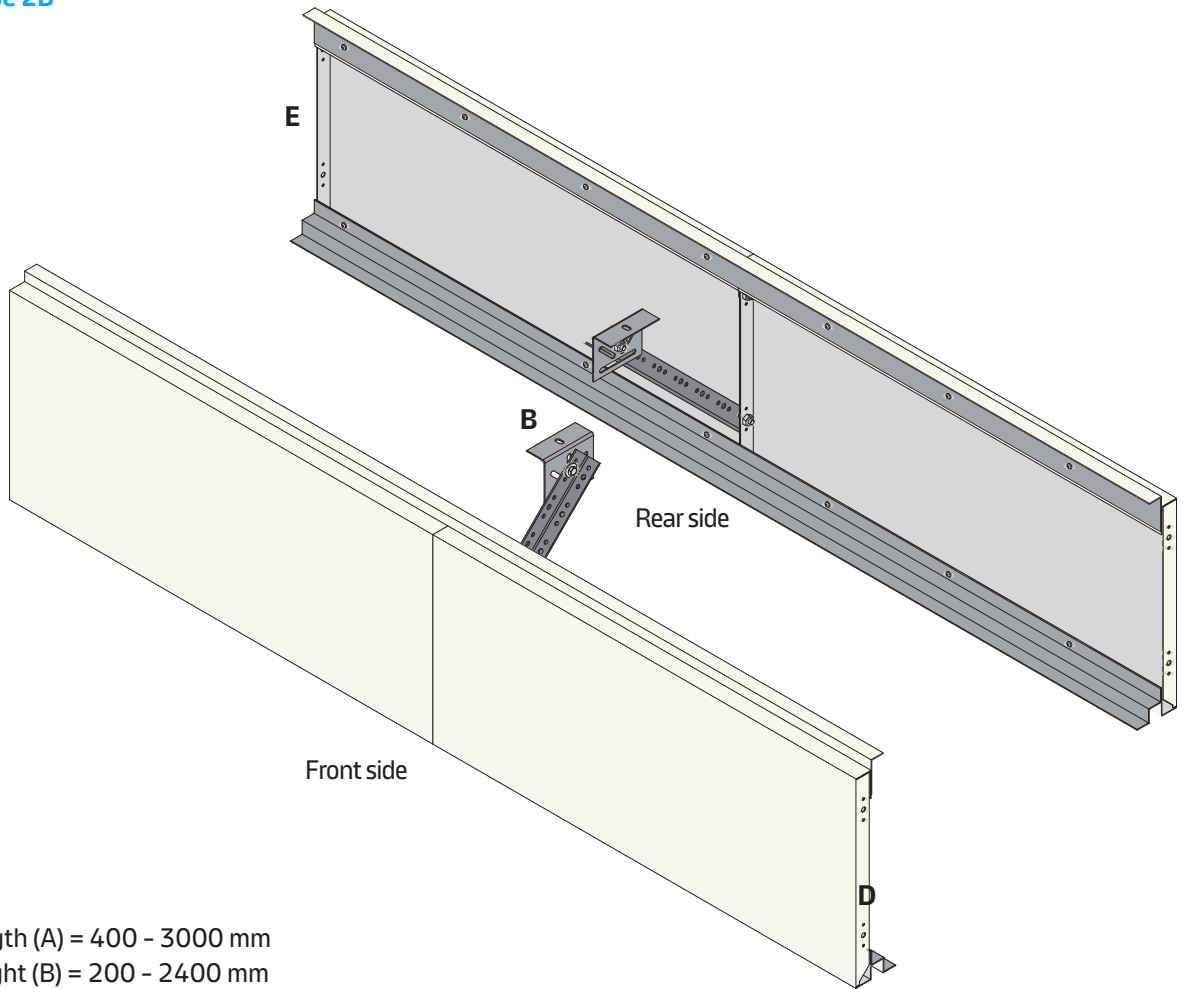

Bulkhead length (A) = 400 - 3000 mm
Bulkhead height (B) = 200 - 2400 mm
Bulkhead size = max. 1.2 m²

Option C1
Vertical closure

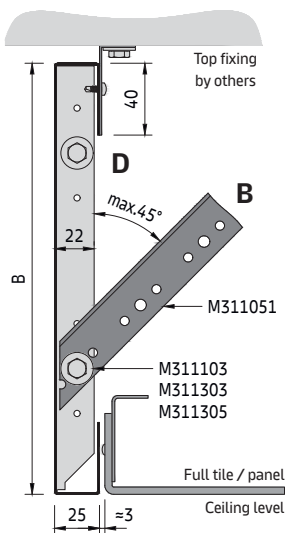

Option C2
Vertical closure with RA 1

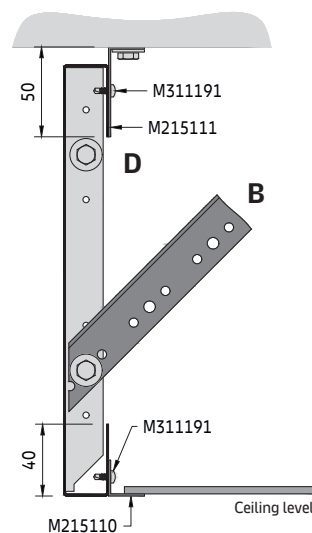

Option C3
Vertical closure with RA 3

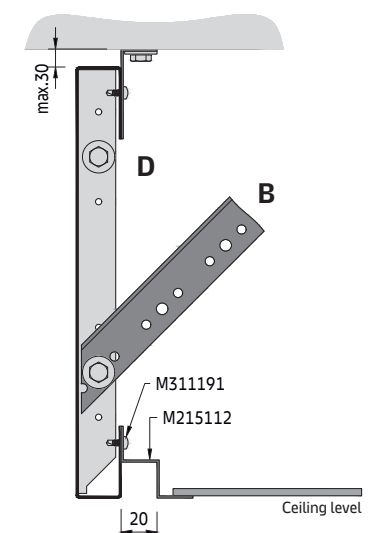

MESH Steel Bulkhead Solutions

T03.002

Detail D

Bulkhead connection

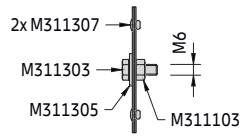

The bulkheads can either be connected by two pop-rivets or a M6 bolt.

Option E1

Cut bulkhead wall detail with RA 1

Perimeters fixed to the bulkhead in a distance of max. 600 mm.
Perimeter solutions on separate datasheet.

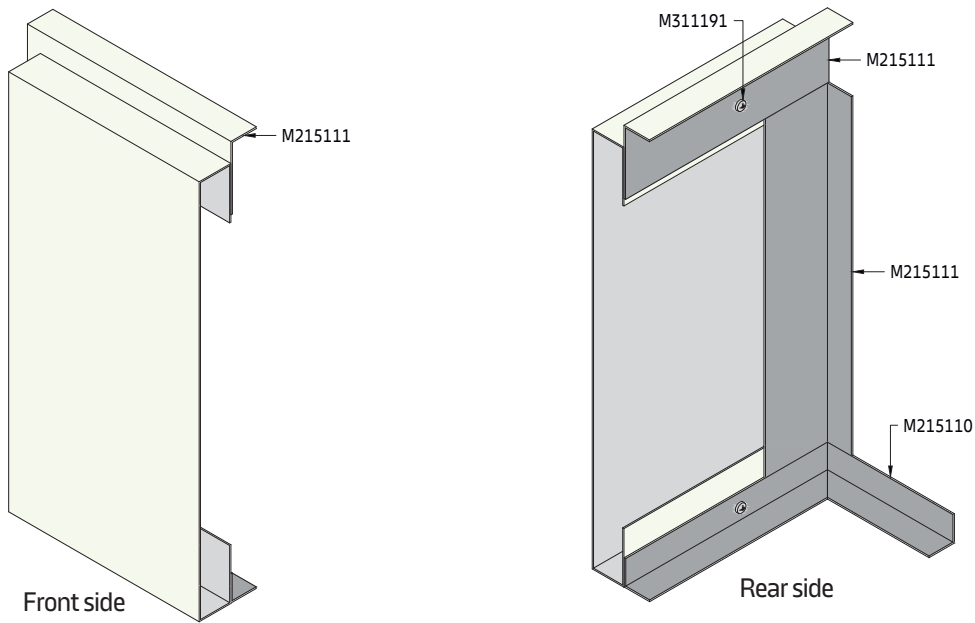

Option E2

Cut bulkhead wall detail with RA 3





MESH R-H 215

Equator IV, Warsaw, Poland © Szymon Polański



Cutting & Modifications

MESH Cutting & Modifications

Cutting

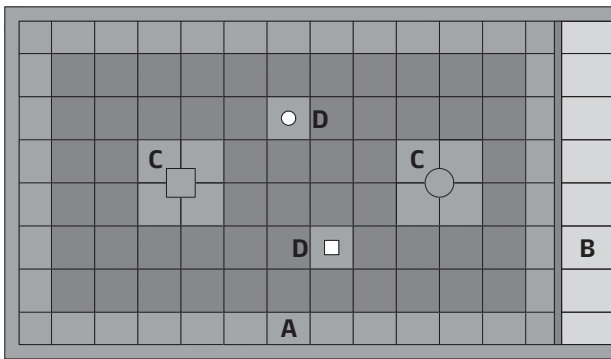

Detail A - Perimeter

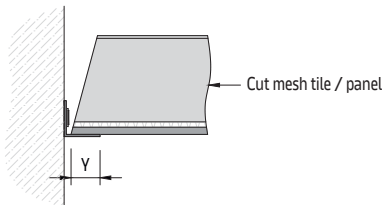

Detail B - Transitions (example with L-Profile)

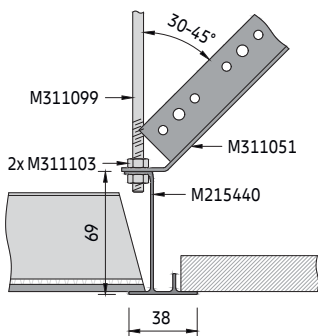

Detail C - Columns

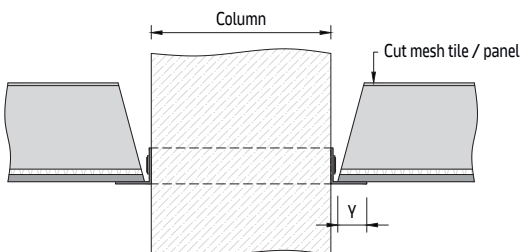

Detail D - Service integrations

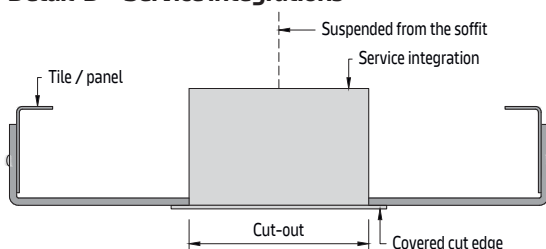

General

Cuts are usually required in the perimeter area (detail **A**) for transitions (detail **B**), columns (details **C**) and cut-outs (detail **D**) for service integrations. The cut edges are covered by a profile or trim and should not be exposed.

A little practice is required for clean and precise cuts, especially for delicate work and tight curves. It is best to try out a few practice pieces beforehand to avoid unnecessary waste.

Wear white gloves to avoid leaving fingerprints on the surface of the tiles / panels. Be careful when cutting sheet mesh, as there is a risk of injury from the sharp cutting edges.

Tiles / Panels

When cutting, the visible side of the tiles / panels should face up to avoid scratching. Measure the distances precisely and transfer the cutting line on the tile / panel.

The minimum contact surface (Y) depends on the selected trim (see perimeter trims). It is imperative that this value is adhered to, as otherwise it is possible to fall down and cause personal injury.

Profiles / Trims

Profiles can be cut with a saw. Visible components, as with tiles / panels, care should be taken not to scratch or damage the visible side.

Service integrations

Generally, additional loads need to be supported with additional hangers from the soffit (detail **D**). Loading the tiles / panels is not permitted.

The service integrations should not affect the visual appearance of the tiles / panels, i.e. no greater sag or stress on the surface.

Small service integrations, such as for example smoke detectors, with little weight are the exception, but must be approved from customer side after installation.

Round and square cut-outs are to be made in the dimensions specified by the supplier of the service integration.

Tiles / panels can be supplied with factory cut-outs upon customer request. See MESH general information pages for options.

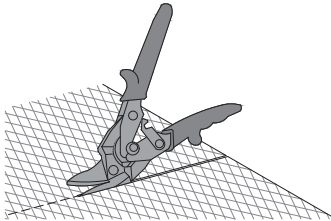
Tools**Tin snips**

Tin snips can be used to cut mesh in thinner gauges. There are different types of tin snips, for different applications. Tin snips work like normal household scissors, but require greater effort due to the hardness of the mesh sheet. Tin snips are not suitable for beginners, as manual cutting can cause the mesh to buckle very quickly.

Furthermore, thin-walled profiles (T-grid, perimeter trims, etc.) can also be cut to length. It is used primarily for butt cuts, but only suitable for mitre cuts to a limited extent.

For an optimal result, the sheet mesh must be placed on the cutting jaw of the tin snips, otherwise it will warp. The tin snips should be opened wide and the mesh should be pushed deep into the mouth. It is important not to close the scissors completely when cutting, but to open them again after $\frac{3}{4}$ of the cutting length and push the material further.

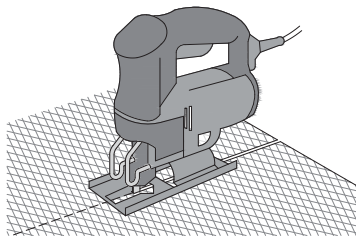
**Jigsaw**

Tiles / panels can be cut with the jigsaw. The variant with a battery and no cable is particularly suitable for mobile use on construction sites. Depending on the mesh pattern, you should check whether a jigsaw or angle grinder works better.

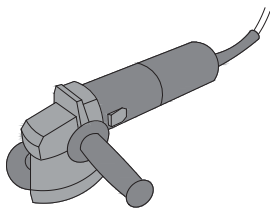
**Angle grinder**

This is only suitable to a limited extent due to the heat development and the resultant discoloration of the mesh. When using angle grinders, particularly for large material thicknesses of ≥ 1.0 mm, the heat development can be reduced by using suitable thin separation sheets, 1.0 mm thick. Even then, proceed with care.

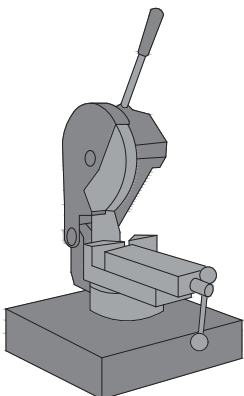
**Mitre saw**

The use of a metal-mitre saw delivers by far the best results for butt and mitre cuts. Proceeding with care (low cutting speed) is also essential.

Avoid damaging the surface with mesh cuttings. When cutting shadow trims it is advantageous to use a suitable wooden batten underlay.



MESH R-H 215

Automobilklub, Warsaw, Poland © Szymon Polański



Maintenance & Cleaning

MESH Maintenance & Cleaning

Maintenance

Access to the ceiling void

In general, all standard and configurable products can be removed individually. This is necessary to ensure maintenance work on the building services.

Extract the elements with care and store them in a place where they will not be damaged during the maintenance work. The products should be stored upright. No additional weight should be placed on it. If the product has a gasket then it should not be stored on it.

Some hinge-down solutions are available to facilitate access. This function can either be applied to all panels or individual elements. If desired, these can be marked on site to identify them. This is done by the installer or the person who will later be responsible for maintenance.

Extraction tools

There are systems where a tool is required to extract or unlock the element. Choosing the right tool is crucial and prevents damage to the product. The correct tool is specified in the Knauf Ceiling Solutions installation manual. Make sure not to damage the product when using the tool. This can be a deformation of the edge, scratches on the surface or damage to the gasket.

Security clips & brackets

Direct access is not possible when using security clips and brackets. If the entire ceiling gets locked, the modules have to be dismantled from the last one that was not secured.

Instructions

The person responsible for building maintenance should receive detailed instructions and have access to a tool where needed. Extraction tools are offered by Knauf Ceiling Solutions.

Cleaning

General

Knauf Ceiling Solutions mesh ceilings are available with different colours and patterns, of which the visible face can be cleaned using a variety of types and methods.

The visible surface is electrostatically powder-coated as standard and is high durable.

Whenever the coated elements are touched, this should always be done with soft white gloves, otherwise fingerprints will be left on the surface, which makes cleaning more time consuming.

Normally, ceiling components do not need to be cleaned for the duration of their use in most standard applications. Nevertheless, it may be necessary to clean local soiling frequently to maintain their appearance. This is not necessary for functional reasons to maintain the fitness for use over the entire service life.

The frequency of cleaning will depend on the efficiency of the heating, ventilation and air conditioning system within the building and the type of occupancy. This can only be determined after the building is occupied.

The mechanical stresses of cleaning (scrubbing) may lead to changes to the surface. Do not apply excessive pressure to the surface as this may deform it.

Highly adhesive dirt (grease, oils, acids and bases) can be resistant to cleaning and can affect the surface permanently. If this cannot be removed by normal washing, then a small number of thinners can be used on the stain. However, care should be taken as this could affect the gloss level of the coated finish. It is recommended to test the proposed cleaning method on a sample piece or a non-visible part of the ceiling. The cleaning should also be carried out over a large area and not limited to individual tiles or small areas.

High levels of moisture exposure due to regular cleaning or room climate conditions may cause increased corrosion protection requirements with regard to the substructure and the attachment.

Additional measures must be taken into account if the suspended ceiling is subject to pressure.

MESH Maintenance & Cleaning

V03

Resistance to solvents

Coated surfaces get softened or swollen within minutes or hours by organic solvents. Changes in the degree of gloss are possible. Generally, coated surfaces are moderately or poorly resistant to organic solvents. Fuel can also strongly attack powder-coated surfaces.

Resistance to water-based acids, alkalis, salts

Coated surfaces are highly resistant against purely water-based chemicals. Even by lack of wetting they scarcely get attacked by strong acids and alkaline solution. Strong oxidisers may change the color or even discolor. Preservatives, detergents, disinfectants - if solvent-based, can attack the surface.

Resistance to colorants

Colorants from red wine, tea, coffee, inks, berries and many similar can migrate into the coating layer and stay permanently. It does not attack or damage the surface. These resistances are difficult to predict and should always be checked case by case.

Recommendations

- The surface temperature of the coated elements should not exceed 25°C during the cleaning.
- Only use clean and pure water with slight additions of neutral or weakly alkaline detergents. With metallic coatings use only neutral cleaners.
- Do not use abrasive, scratching products, e.g. sanding pastes. Strong rubbing is prohibited.
- Do not use organic solvents containing ketones, esters, aromatics, halogenated hydrocarbons, etheric oils or similar.
- Do not use acids or high alkalic products.
- The action time of the products used should not exceed one hour.
- If the cleaning process has to be repeated, a 24-hour waiting period has to be observed.

MESH Maintenance & Cleaning

V03

**Dry cleaning**

- Daily cleaning of all mesh products

For standard cleaning of dust, loose dirt or deposit, a soft brush, a clean, dry, soft white cloth, a normal vacuum cleaner with a soft brush can be used.

**Damp cleaning**

- Daily cleaning of all mesh products

For more intensive cleaning, the surfaces can be damp cleaned. This should be carried out with a wrung-out soft cloth or sponge. After cleaning, the surface should be dried with a soft cloth.

**Wet cleaning**

- Daily cleaning of all mesh products

Wet cleaning should be carried out with lukewarm water (up to 40°C), using a sponge and mild cleaning agent (with a pH value between 7 and 9). It is important that the edges and the reverse side of the tile do not come into contact with moisture. After cleaning the surface should be dried with a soft cloth.

**Focused compressed air cleaning**

- Daily cleaning of all mesh products

The surface can be cleaned using focus compressed air. The apparatus used should be a cleaner that generates steam under pressure (8 bar and 175°C).

**Pressure cleaning**

- Twice yearly cleaning of all mesh products

Pressure cleaning (no steam) is carried out with the following technical restrictions:

- Water temperature: max. 40°C
- Working pressure: max. 80 bar, flow rate max. 500 l/h
- Minimum distance to surface: 1.0 m

Penetration of water into the suspension system should be avoided. Following cleaning, the surface should be dried.

**Resistance to popular disinfectants**

- Daily cleaning of all mesh products

Due to large number of types of disinfectants, always test a small area first.



MESH MicroLook 8
Canada Square, Canary Wharf, London, United Kingdom © Dave Parker

Build on us.

**Knauf Ceilings Holding GmbH
Am Bahnhof 7
97346 Iphofen, Germany**

Phone: +49 9323 31-0

E-mail: zentrale@knauf.com

www.knauf.com

Commercial Register: District Court, Würzburg

Registration No.: HRA 6031

VAT No. pursuant to § 27a of the German VAT Act
(Umsatzsteuergesetz): DE317846056

Board of Directors: Lars Klodwig, Karl Wenig,
Daniel Wolf

EN - 09/2025